



1

Elring-Service

2022



Das Original



Elring-Service-Hotline

 +49 7123 724-799

service@elring.com



1/3

V 1



- 2 Alfa Romeo
- 46 Audi
- 356 Audi (FAW)
- 386 BMW
- 566 Changan
- 572 Chevrolet/Daewoo
- 630 Chrysler/Dodge/Jeep
- 668 Citroën
- 790 Dacia
- 806 Daihatsu
- 820 Fiat
- 970 Ford

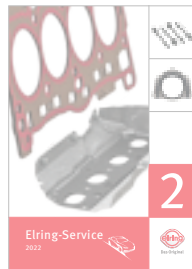

2/3

V 1



- 2 Honda
- 80 Hyundai
- 140 Iveco
- 172 Kia
- 218 Lada
- 230 Lancia
- 274 Land Rover
- 314 MAN
- 320 Mazda
- 398 Mercedes-Benz
- 686 Mini
- 708 Mitsubishi
- 778 Nissan
- 890 Opel/Vauxhall
- 1074 Peugeot



3/3

V 1



- 2 Porsche
- 86 Renault
- 226 Rover
- 244 Saab
- 270 Seat
- 396 Škoda
- 490 Smart
- 502 SsangYong
- 514 Subaru
- 564 Suzuki
- 602 Toyota
- 734 Volkswagen
- 1128 Volvo

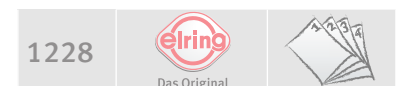



1. Exclusion of liability

All information in this catalog has been carefully prepared by us. We accept no liability for the accuracy and completeness of data contained in this catalog. Any claim of damages against us arising from the use of the data contained in the catalog, or the use of any erroneous or incomplete data, is excluded. Subject to technical developments and changes. Before installing any replacement parts named in this catalog, it must be checked whether the parts are suitable for the intended purpose. Our technical service department is available for this at any time. In case of doubt, seek clarification. We expressly give notice that all replacement parts must be installed by trained, qualified personnel.

2. Notification of copyright and trademark law

The copyright for texts, graphics, and image documents created by us remains ours. Any imitation, reproduction, or use of such objects in other printed or electronic publications requires our written permission and citation of the source.

3. Terms and conditions

We give express notice that delivery is made exclusively under our general terms and conditions. The current edition of our general sales and delivery conditions is available on our Internet site, at: www.elring.de/agb_en We will be happy to send them to you upon request.

4. Miscellaneous

Names, descriptions, and numbers of vehicles and manufacturers and the like are intended solely for internal comparison purposes. The same applies to original spare part numbers from the vehicle and engine manufacturers. They are not an indication of origin and must not be used with vehicle owners.

Previous editions become obsolete with the publication of this catalog.

1. Haftungsausschluss

Sämtliche Angaben in diesem Katalog wurden von uns sorgfältig und fundiert bearbeitet. Wir übernehmen für die Richtigkeit und Vollständigkeit der im Katalog enthaltenen Angaben keine Gewähr. Sämtliche Ersatzansprüche gegen uns, die durch die Nutzung der im Katalog enthaltenen Angaben bzw. durch die Nutzung eventuell fehlerhafter oder unvollständiger Angaben verursacht wurden, sind ausgeschlossen. Laufende technische Entwicklungen oder Änderungen bleiben vorbehalten. Vor dem Einbau der in diesem Katalog genannten Ersatzteile ist zu prüfen, ob die Teile für den geplanten Verwendungszweck geeignet sind. Hierfür steht unser technischer Kundendienst jederzeit zur Verfügung. In allen Zweifelsfällen sollte Rücksprache erfolgen. Wir weisen ausdrücklich darauf hin, dass alle Ersatzteile von geschultem Fachpersonal eingebaut werden müssen.

2. Hinweise zum Urheber- und Kennzeichnungsrecht

Das Urheberrecht für die von uns erstellten Texte, Grafiken und Bilddokumente bleibt allein bei uns. Eine Nachahmung, Vervielfältigung oder Verwendung solcher Objekte in anderen gedruckten oder elektronischen Publikationen ist nur mit unserer schriftlichen Genehmigung und mit Quellenangabe gestattet.

3. AGB

Wir weisen ausdrücklich darauf hin, dass Lieferungen ausschließlich zu unseren Allgemeinen Verkaufs- und Lieferbedingungen erfolgen. Die aktuelle Fassung unserer Allgemeinen Verkaufs- und Lieferbedingungen ist auf unserer Internetseite unter: www.elring.de/agb_de veröffentlicht. Auf Wunsch senden wir Ihnen diese auch gerne zu.

4. Sonstiges

Namen, Beschreibungen, Nummern von Fahrzeugen und Herstellern und Ähnliches sind ausschließlich zu internen Vergleichszwecken bestimmt. Gleiches gilt für Original-Ersatzteilnummern der Fahrzeug- und Motorenhersteller. Sie sind keine Herkunftsbezeichnung und dürfen Fahrzeugbesitzern gegenüber nicht verwendet werden.

Mit Erscheinen dieses Katalogs verlieren frühere Ausgaben ihre Gültigkeit.

1. Limitation de responsabilité

Nous avons apporté le plus grand soin à la rédaction et à la vérification des informations figurant dans ce catalogue. Toutefois, nous ne pouvons garantir de manière absolue l'exactitude et l'intégrité des informations fournies. En conséquence, nous ne pouvons en aucun cas être tenus responsables de tout préjudice résultant de l'utilisation des informations de ce catalogue ou de l'utilisation d'une information erronée ou incomplète. Nous nous réservons le droit de modifier ou d'adapter nos produits aux évolutions technologiques. Avant de procéder au montage des pièces de rechange citées dans ce catalogue, vérifiez si celles-ci sont adaptées à l'utilisation prévue. Notre service clientèle est à votre disposition pour tout renseignement à ce sujet. En cas de doute, il est fortement recommandé de lui demander conseil. Nous vous avisons explicitement que tout remplacement de pièce doit impérativement être effectué par des techniciens spécialisés.

2. Propriété intellectuelle et propriété industrielle

Tous les textes, graphismes et éléments visuels créés par nous nous sont réservés au titre de la propriété industrielle. A ce titre, toute reproduction, adaptation ou utilisation, totale ou partielle, sur un support papier ou informatique, ne pourra être faite sans notre autorisation écrite et sans citation explicite de la source.

3. CGV

Nous vous avisons explicitement que les présentes conditions générales de vente sont les seules applicables aux produits et services fournis par notre société. La version actuellement en vigueur de nos conditions générales de vente est disponible sur notre site Internet : www.elring.de/agb_en

Celles-ci peuvent vous être envoyées par courrier sur simple demande.

4. Dispositions diverses

Les noms, descriptifs, numéros de véhicules et de constructeurs et autres références sont mentionnés à des fins exclusives de comparaison en interne. Ceci concerne également les numéros des pièces de rechange d'origine des constructeurs automobiles et motoristes. Ces numéros ne constituent pas une indication d'origine et ne doivent pas être utilisés à l'endroit des propriétaires des véhicules.

Ce catalogue remplace et annule les éditions précédentes.





1. Exención de responsabilidad

Todos los datos de este catálogo han sido elaborados de manera cuidadosa y fundamentada. La empresa no se responsabiliza por la corrección ni por la exhaustividad de los datos incluidos en el catálogo. No se admiten reclamaciones de indemnización derivadas del uso de datos incluidos en este catálogo o provocadas por la presencia de datos ocasionalmente erróneos o incompletos. La empresa se reserva el derecho de introducir modificaciones y mejoras técnicas. Antes de montar las piezas de recambio mencionadas en este catálogo, es necesario verificar si las piezas son adecuadas para el uso previsto. Nuestro servicio técnico de atención al cliente está siempre a su disposición. En caso de duda, debe realizarse la consulta correspondiente. Se hace constar expresamente que todas las piezas de recambio deben ser montadas por personal técnico cualificado.

2. Notas de copyright y derechos de autor

Los derechos de autor correspondientes a textos, gráficos e imágenes elaborados por la empresa son propiedad exclusiva de la empresa. La copia, reproducción o utilización de dichos elementos en otras publicaciones impresas o electrónicas sólo están permitidas si existe una autorización por escrito de la empresa y se menciona la fuente.

3. Condiciones Generales

Se hace constar expresamente que las entregas sólo tienen lugar en el marco de nuestras Condiciones Generales de Venta y Suministro. La versión vigente de las Condiciones Generales de Venta y Suministro está publicada en nuestro sitio de Internet en la dirección:

www.elring.de/agb_en

Si lo desea, podemos enviarle un ejemplar.

4. Otros

Los nombres, las descripciones, los números de vehículos y fabricantes y similares se utilizan exclusivamente con fines comparativos a nivel interno. Lo mismo es válido para los números de piezas de recambio originales de los fabricantes de vehículos y motores. No son denominaciones de origen y no deben utilizarse ante los propietarios de los vehículos.

Con la aparición de este catálogo pierden su validez las versiones anteriores.

1. Esclusione di responsabilità

Tutti i dati riportati nel presente catalogo sono stati da noi accuratamente elaborati su basi fondate. Non forniamo alcuna garanzia riguardo all'esattezza e alla completezza dei dati riportati nel catalogo. È escluso qualsiasi diritto di rimborso nei nostri confronti, qualora sia dovuto all'applicazione dei dati contenuti nel catalogo, ovvero all'applicazione di eventuali dati errati o incompleti. Ci riserviamo di apportare eventuali modifiche o di adeguarci agli sviluppi tecnologici in corso. Prima di montare i pezzi di ricambio riportati nel presente catalogo, occorre verificare se i pezzi sono adeguati agli scopi d'utilizzo previsti. Il nostro servizio clienti per problematiche tecniche è a vostra completa disposizione. In caso di dubbio, rivolgersi sempre al servizio competente. Facciamo espressamente notare che tutti i pezzi di ricambio devono essere montati da personale tecnico qualificato.

2. Avvertenze sui diritti d'autore e sul diritto ad apporre il contrassegno

I diritti d'autore per i testi, i grafici e i documenti fotografici da noi prodotti sono di nostro esclusivo appannaggio. L'imitazione, la riproduzione o l'utilizzo di tali oggetti in altre pubblicazioni stampate o elettroniche sono consentite esclusivamente previa nostra autorizzazione scritta e con citazione della fonte.

3. CG

Facciamo espressamente notare che le spedizioni avvengono esclusivamente alle nostre condizioni generali di fornitura e di vendita. La versione attuale delle nostre condizioni generali di fornitura e di vendita può essere consultata sulla nostra pagina web:

www.elring.de/agb_en

Su richiesta, saremo lieti di inviarvene una copia.

4. Varie

Nomi, descrizioni, numeri di veicoli e produttori, nonché altri dati analoghi sono destinati ai soli scopi comparativi interni. Lo stesso vale per i numeri dei pezzi di ricambio originali del produttore dei motori e del veicolo. Essi non presentano alcuna indicazione di origine e non devono essere utilizzati da parte del proprietario del veicolo.

Con la pubblicazione del presente catalogo, le edizioni precedenti non sono più valide.

1. Исключение ответственности

Все указания и сведения в данном каталоге отбиралась и обрабатывались тщательным и обоснованным образом. Мы не предоставляем какой-либо гарантии за правильность и полноту сведений, приведенных в каталоге. Направление каких-либо требований на возмещение убытков, связанных с использованием сведений, приведенных в каталоге, или связанных с использованием возможных ошибочных или неполных указаний полностью исключается. Мы оставляем за собой право вносить изменения в связи с текущим техническим развитием или усовершенствованиями. Перед монтажом приведенных в данном каталоге запасных частей необходимо проконтролировать, соответствуют ли эти детали запланированному назначению. Для этих целей в любое время в Вашем распоряжении находится наша техническая служба. В случае возникновения сомнений необходимо получить консультацию. Мы особо указываем на то, что монтаж всех запасных частей должен осуществляться специально обученный персонал.

2. Указания в отношении авторских прав и прав на торговый знак

Авторские права на созданные нами тексты, графические изображения и фотографии остаются исключительно за нами. Любое последующее копирование, размножение или использование этих объектов права в других печатных или публикациях разрешается только при наличии письменного разрешения с нашей стороны и с обязательным указанием источника.

3. Общие условия заключения торговых сделок

Мы особо указываем на то, что все поставки осуществляются исключительно в соответствии с нашими общими условиями продаж и поставок. Действующая формулировка наших общих условий продаж и поставок опубликована на нашем сайте:

www.elring.de/agb_en По Вашему желанию мы можем их выслать Вам.

4. Прочие положения

Названия, описания, номера транспортных средств и производителей и иные похожие сведения приводятся исключительно для целей внутреннего сопоставления. То же самое относится к оригинальным номерам запчастей и комплектующих производителей транспортных средств и двигателей. Такие сведения не являются обозначениями происхождения и не могут каким-либо образом использоваться в отношении владельцев транспортных средств.

С опубликованием данного каталога все предыдущие его издания теряют свою силу.

WWW.ELRING.COM

ALFA ROMEO



ALFA ROMEO	ccm	kW	→	→	→	→
4C	4	1742	177	03/2013	12/2020	960 A1.000 20
Alfa 145	4	1370	76	12/1996	01/2001	AR 33503 AR 38501 14
Alfa 145	4	1598	88	12/1996	01/2001	AR 38201 AR 67601 18
Alfa 145	4	1598	82	09/1997	12/2000	AR 32102 18
Alfa 145	4	1747	103	12/1996	12/1998	AR 38401 AR 67106 AR 67199 20
Alfa 145	4	1747	106	03/1998	01/2001	AR 32201 20
Alfa 145	4	1970	110	10/1995	01/2001	AR 67204 38
Alfa 145	4	1970	114	03/1998	01/2001	AR 32301 36
Alfa 145 JTD	4	1910	77	02/1999	01/2001	AR 32302 30
Alfa 145 JTD	4	1929	68	07/1994	02/1999	AR 67501 32
Alfa 145 TD	4	1929	66	10/1994	02/1999	AR 33601 AR 67501 32
Alfa 146	4	1370	76	11/1996	01/2001	AR 33503 AR 38501 14
Alfa 146	4	1598	88	11/1996	10/2001	AR 38201 AR 67601 18
Alfa 146	4	1598	82	09/1997	12/2000	AR 32102 18
Alfa 146	4	1747	103	11/1996	01/2001	AR 38401 AR 67106 20
Alfa 146	4	1747	106	03/1998	01/2001	AR 32201 20
Alfa 146	4	1970	110	10/1995	01/2001	AR 67204 38
Alfa 146	4	1970	114	03/1997	10/2001	AR 32301 36
Alfa 146 JTD	4	1910	77	02/1999	01/2001	AR 32302 30
Alfa 146 JTD	4	1929	68	05/1995	09/1996	AR 67501 32
Alfa 146 TD	4	1929	66	12/1994	02/1999	AR 33601 AR 67501 32
Alfa 147	4	1598	77	01/2001	03/2010	AR 37203 18
Alfa 147	4	1598	88	01/2001	03/2010	AR 32104 18
Alfa 147	4	1970	110	01/2001	03/2010	AR 32310 38
Alfa 147	4	1970	121	07/2002	05/2005	937 A1.000 36
Alfa 147	6	3179	184	02/2003	03/2010	932 A.000 44
Alfa 147 JTD	4	1910	81	10/2000	08/2002	937 A2.000 24
Alfa 147 JTD	4	1910	85	04/2001	03/2010	937 A2.000 24
Alfa 147 JTD	4	1910	103	11/2002	03/2010	192 A5.000 24
Alfa 147 JTD	4	1910	74	06/2003	03/2010	182 B9.000 22
Alfa 147 JTD	4	1910	93	09/2003	09/2004	937 A4.000 26
Alfa 147 JTD	4	1910	100	10/2004	03/2010	192 B1.000 26

ALFA ROMEO	ccm	kW	→	→	→	→
Alfa 147 JTDM	4	1910	110	09/2004	03/2010	937 A5.000 26
Alfa 147 JTDM	4	1910	85	10/2004	03/2010	939 A7.000 28
Alfa 147 JTDM	4	1910	88	07/2005	03/2010	937 A3.000 24
Alfa 147 JTDM	4	1910	125	06/2008	03/2010	937 A6.000 28
Alfa 155	4	1598	88	05/1996	12/1997	AR 67601 18
Alfa 155	4	1747	103	05/1996	12/1997	AR 67106 20
Alfa 155	4	1970	110	03/1995	12/1997	AR 67204 AR 67299 38
Alfa 155 TD	4	1929	66	04/1993	12/1997	AR 67501 32
Alfa 155 TD	4	2499	92	04/1993	12/1997	VM 07 B 42 VM 31 B 44
Alfa 156	4	1598	82	09/1997	09/2005	AR 32102 18
Alfa 156	4	1598	88	09/1997	05/2006	AR 32102 AR 32103 AR 32104 AR 67601 18
Alfa 156	4	1747	103	02/1997	05/2006	AR 32205 20
Alfa 156	4	1747	106	09/1997	10/2000	AR 32201 20
Alfa 156	4	1970	114	09/1997	06/2002	AR 32301 AR 32310 36 38
Alfa 156	4	1970	110	10/2000	03/2002	AR 32310 38
Alfa 156	4	1970	119	03/2001	05/2006	932 A2.000 36
Alfa 156	4	1970	122	03/2002	05/2006	937 A1.000 36
Alfa 156	6	2492	140	02/1997	08/2003	AR 32401 AR 32402 42
Alfa 156	6	2492	141	02/1997	05/2006	AR 32405 42
Alfa 156	6	3179	184	03/2002	05/2006	932 A.000 44
Alfa 156 JTD	4	1910	77	09/1997	10/2000	AR 32302 30
Alfa 156 JTD	4	1910	81	10/2000	05/2001	AR 37101 30
Alfa 156 JTD	4	1910	85	05/2001	05/2006	937 A2.000 24
Alfa 156 JTD	4	1910	100	11/2002	11/2004	192 B1.000 26
Alfa 156 JTD	4	1910	103	11/2002	05/2006	192 A5.000 24
Alfa 156 JTD	4	1910	93	11/2003	05/2006	937 A4.000 26
Alfa 156 JTD	4	1910	110	07/2004	05/2006	937 A5.000 26
Alfa 156 JTD	5	2387	100	09/1997	09/2003	AR 32501 42
Alfa 156 JTD	5	2387	103	10/2000	05/2006	839 A6.000 40
Alfa 156 JTD	5	2387	110	03/2002	05/2006	841 C000 40
Alfa 156 JTD	5	2387	120	06/2003	05/2006	841 M.000 841 N.000 40
Alfa 156 JTD	5	2387	129	10/2003	05/2006	841 G.000 40
Alfa 159	4	1742	147	05/2009	12/2012	939 B1.000 20



ALFA ROMEO	ccm	kW	→	→			
Alfa 159	4	1796	103	06/2005	11/2011	939 A4.000	22
Alfa 159	4	1859	118	09/2005	11/2011	939 A6.000	22
Alfa 159	4	2198	136	09/2005	11/2011	939 A5.000	40
Alfa 159 JTDM	4	1910	85	09/2005	11/2011	937 A7.000 939 A7.000	28
Alfa 159 JTDM	4	1910	88	09/2005	11/2011	939 A1.000	28
Alfa 159 JTDM	4	1910	100	09/2005	11/2011	937 A8.000 939 A8.000	30
Alfa 159 JTDM	4	1910	110	09/2005	11/2011	939 A2.000	30
Alfa 159 JTDM	4	1956	120	05/2009	11/2011	844 A2.000	34
Alfa 159 JTDM	4	1956	125	05/2009	11/2011	939 B3.000	34
Alfa 159 JTDM	4	1956	100	06/2010	11/2011	939 B4.000	34
Alfa 159 JTDM	5	2387	147	09/2005	11/2011	939 A3.000	40
Alfa 159 JTDM	5	2387	154	05/2007	12/2012	939 A9.000	40
Alfa 164 TD	4	2499	84	06/1987	09/1992	VM 84 A	42
Alfa 164 TD	4	2499	92	09/1992	09/1998	VM 08 B VM 32 B	42 44
Alfa 166	4	1970	114	09/1998	10/2000	AR 34103	38
Alfa 166	4	1970	110	10/2000	06/2007	AR 36301	38
Alfa 166	6	2492	140	09/1998	12/2006	AR 34201	42
Alfa 166	6	2492	138	10/2000	06/2007	AR 36201	42
Alfa 166	6	2959	166	09/1998	06/2007	AR 34301 AR 34302	44
Alfa 166	6	2959	162	10/2000	06/2007	AR 36101	44
Alfa 166	6	3179	176	10/2003	06/2007	936 A.000	44
Alfa 166 JTD	5	2387	100	09/1998	10/2000	AR 34202	42
Alfa 166 JTD	5	2387	103	10/2000	06/2007	839 A6.000	40
Alfa 166 JTD	5	2387	110	04/2002	06/2007	841 C000	40
Alfa 166 JTD	5	2387	120	10/2003	06/2007	841 M.000 841 N.000	40
Alfa 166 JTD	5	2387	129	10/2003	06/2007	841 G.000 841 H.000	40
Alfa 166 JTD	5	2387	136	07/2005	06/2007	841 M.000 936 B.000	40
Alfa 166 JTD	5	2387	132	07/2006	06/2007	841 M.000	40
Alfa 75 TD	4	2393	82	01/1989	02/1992	VM 81 A	42
Alfa 90 TD	4	2393	81	10/1984	07/1987	VM 81 A	42
Alfetta TD	4	2393	70	04/1983	12/1984	VM4HT 2.4	42
Brera	4	1742	147	05/2009	06/2010	939 B1.000	20
Brera	4	2198	136	01/2006	05/2011	939 A5.000	40

ALFA ROMEO	ccm	kW	→	→			
Brera JTDM	4	1956	120	03/2008	06/2010	844 A2.000	34
Brera JTDM	4	1956	125	05/2009	06/2010	939 B3.000	34
Brera JTDM	5	2387	147	01/2006	03/2011	939 A3.000	40
Brera JTDM	5	2387	154	05/2007	03/2011	939 A9.000	40
Giulia	4	1995	206	08/2016		EC2	38
Giulietta	4	1368	85	04/2010	02/2016	940 A6.000	12
Giulietta	4	1368	88	04/2010	12/2020	198 A4.000 940 B7.000	10 12
Giulietta	4	1368	120	04/2010	10/2018	955 A8.000	14
Giulietta	4	1368	125	04/2010	12/2020	940 A2.000	14
Giulietta	4	1368	77	04/2011	02/2017	940 B1.000 940 B8.000	12
Giulietta	4	1368	110	09/2014	01/2020	940 C2.000	12
Giulietta	4	1742	169	04/2010	09/2013	940 A1.000	20
Giulietta	4	1742	173	04/2010	02/2016	940 A1.000	20
Giulietta	4	1742	177	09/2013	10/2018	940 B2.000 960 A1.000	20
Giulietta JTDM	4	1598	77	04/2010	02/2016	940 A3.000	16
Giulietta JTDM	4	1598	88	02/2015	12/2020	552 80 444 940 C1.000 940 C5.000	16
Giulietta JTDM	4	1598	85	09/2015	10/2018	940 C5.000	16
Giulietta JTDM	4	1956	100	04/2010	02/2016	940 A8.000 940 B6.000 940 C4.000	34 36
Giulietta JTDM	4	1956	103	04/2010	12/2020	940 A5.000	34
Giulietta JTDM	4	1956	120	04/2010	10/2018	940 A7.000 940 B9.000	34
Giulietta JTDM	4	1956	125	04/2010	12/2020	552 83 099 940 A4.000 940 B4.000	32 34
Giulietta JTDM	4	1956	110	08/2013	01/2020	940 B5.000 940 C3.000	34 36
Giulietta JTDM	4	1956	129	11/2013	12/2020	940 B4.000	34
GT	4	1747	103	11/2003	09/2010	AR 32205	20
GT	4	1970	121	11/2003	09/2010	932 A2.000 937 A1.000	36
GT	4	1970	110	09/2006	12/2008	932 A2.000	36
GT	4	1970	119	12/2006	09/2010	932 A2.000	36
GT	6	3179	176	11/2003	09/2010	936 A.000	44
GT	6	3179	177	09/2006	12/2007	936 A.000	44
GT JTD	4	1910	110	11/2003	09/2010	937 A5.000	26
GT JTD	4	1910	125	05/2008	09/2010	937 A6.000	28

ALFA ROMEO



ALFA ROMEO	ccm	kW	→	→			
GTV	4	1747	106	05/1998	10/2005	AR 32201	20
GTV	4	1970	110	06/1995	10/2005	AR 16201 AR 32310	38
GTV	4	1970	114	09/1997	03/2003	AR 32301	36
GTV	4	1970	121	04/2003	10/2005	937 A1.000	36
GTV	6	2959	162	10/1996	10/2000	AR 16102	44
GTV	6	2959	160	10/2000	10/2005	AR 16105	44
GTV	6	3179	176	04/2003	10/2005	936 A6.000	44
Mito	2	875	63	07/2011	12/2013	312 A2.000	8
Mito	2	875	77	04/2013	08/2018	199 B6.000	8
Mito	2	875	74	12/2013	08/2018	199 B6.000	8
Mito	4	1368	58	08/2008	08/2013	955 A1.000	10
Mito	4	1368	88	08/2008	10/2018	198 A4.000	10
Mito	4	1368	114	08/2008	06/2011	199 A8.000	10
Mito	4	1368	70	09/2008	08/2013	199 A6.000	10
Mito	4	1368	110	09/2008	06/2011	198 A1.000	10
Mito	4	1368	77	09/2009	08/2013	955 A6.000	14
Mito	4	1368	125	09/2009	10/2018	940 A2.000	14
Mito	4	1368	99	10/2009	12/2014	955 A2.000 955 A7.000	12
Mito	4	1368	120	10/2009	10/2018	955 A8.000	14
Mito	4	1368	57	03/2011	10/2018	350 A1.000	14
Mito	4	1368	51	05/2011	10/2018	955 A9.000	14
Mito	4	1368	103	12/2013	10/2018	955 B1.000	12
Mito JTDM	4	1598	85	08/2008	08/2015	955 A4.000	16
Mito JTDM	4	1598	88	08/2008	08/2015	198 A2.000 955 A3.000	16
Mito Multijet	4	1248	66	08/2008	08/2010	199 A3.000 955 B2.000	810
Mito Multijet	4	1248	70	09/2009	10/2018	199 B1.000 330 A1.000	810
Mito Multijet	4	1248	62	01/2011	12/2015	199 B4.000	8
Mito Multijet	4	1248	59	12/2013	12/2015	199 B8.000	8
Spider	4	1742	147	05/2009	03/2011	939 B1.000	20
Spider	4	1747	106	05/1998	04/2005	AR 32201	20
Spider	4	1970	110	06/1995	04/2005	AR 16201 AR 32310	38
Spider	4	1970	114	05/1998	08/2000	AR 32301	36
Spider	4	1970	121	04/2003	04/2005	937 A1.000	36
Spider	4	2198	136	03/2006	03/2011	939 A5.000	40

ALFA ROMEO	ccm	kW	→	→			
Spider	6	2959	160	09/1994	04/2005	AR 16105	44
Spider	6	2959	162	01/1999	10/2003	AR 16102	44
Spider	6	3179	176	04/2003	04/2005	936 A6.000	44
Spider JTDM	4	1956	120	04/2009	03/2011	844 A2.000	34
Spider JTDM	4	1956	125	05/2009	06/2010	939 B3.000	34
Spider JTDM	5	2387	147	03/2006	03/2011	939 A3.000	40
Spider JTDM	5	2387	154	03/2008	03/2011	939 A9.000	40
Stelvio	4	1995	206	12/2016		EC2	38

ALFA ROMEO



Das Original

ALFA ROMEO



182 B9.000	4	1910	22
192 A5.000	4	1910	24
192 B1.000	4	1910	26
198 A1.000	4	1368	10
198 A2.000	4	1598	16
198 A4.000	4	1368	10
199 A3.000	4	1248	8
199 A6.000	4	1368	10
199 A8.000	4	1368	10
199 B1.000	4	1248	8
199 B4.000	4	1248	8
199 B6.000	2	875	8
199 B8.000	4	1248	8
312 A2.000	2	875	8
330 A1.000	4	1248	10
350 A1.000	4	1368	14
552 80 444	4	1598	16
552 83 099	4	1956	32
839 A6.000	5	2387	40
841 C000	5	2387	40
841 G.000	5	2387	40
841 H.000	5	2387	40
841 M.000	5	2387	40
841 N.000	5	2387	40
844 A2.000	4	1956	34
932 A.000	6	3179	44
932 A2.000	4	1970	36
936 A.000	6	3179	44
936 A6.000	6	3179	44
936 B.000	5	2387	40
937 A1.000	4	1970	36
937 A2.000	4	1910	24
937 A3.000	4	1910	24
937 A4.000	4	1910	26
937 A5.000	4	1910	26
937 A6.000	4	1910	28
937 A7.000	4	1910	28

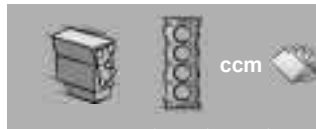

937 A8.000	4	1910	30
939 A1.000	4	1910	28
939 A2.000	4	1910	30
939 A3.000	5	2387	40
939 A4.000	4	1796	22
939 A5.000	4	2198	40
939 A6.000	4	1859	22
939 A7.000	4	1910	28
939 A8.000	4	1910	30
939 A9.000	5	2387	40
939 B1.000	4	1742	20
939 B3.000	4	1956	34
939 B4.000	4	1956	34
939 B5.000	4	1956	34
940 A1.000	4	1742	20
940 A2.000	4	1368	14
940 A3.000	4	1598	16
940 A4.000	4	1956	34
940 A5.000	4	1956	34
940 A6.000	4	1368	12
940 A7.000	4	1956	34
940 A8.000	4	1956	34
940 B1.000	4	1368	12
940 B2.000	4	1742	20
940 B4.000	4	1956	34
940 B5.000	4	1956	34
940 B6.000	4	1956	34
940 B7.000	4	1368	12
940 B8.000	4	1368	12
940 B9.000	4	1956	34
940 C1.000	4	1598	16
940 C2.000	4	1368	12
940 C3.000	4	1956	36
940 C4.000	4	1956	36
940 C5.000	4	1598	16
955 A1.000	4	1368	10
955 A2.000	4	1368	12

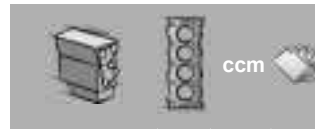

955 A3.000	4	1598	16
955 A4.000	4	1598	16
955 A6.000	4	1368	14
955 A7.000	4	1368	12
955 A8.000	4	1368	14
955 A9.000	4	1368	14
955 B1.000	4	1368	12
955 B2.000	4	1248	10
960 A1.000	4	1742	20
AR 16102	6	2959	44
AR 16105	6	2959	44
AR 16201	4	1970	38
AR 32102	4	1598	18
AR 32103	4	1598	18
AR 32104	4	1598	18
AR 32201	4	1747	20
AR 32205	4	1747	20
AR 32301	4	1970	36
AR 32302	4	1910	30
AR 32303	4	1970	38
AR 32310	4	1970	38
AR 32401	6	2492	42
AR 32402	6	2492	42
AR 32405	6	2492	42
AR 32501	5	2387	42
AR 33503	4	1370	14
AR 33601	4	1929	32
AR 34103	4	1970	38
AR 34201	6	2492	42
AR 34202	5	2387	42
AR 34301	6	2959	44
AR 34302	6	2959	44
AR 36101	6	2959	44
AR 36201	6	2492	42
AR 36202	5	2387	40
AR 36301	4	1970	38
AR 37101	4	1910	30

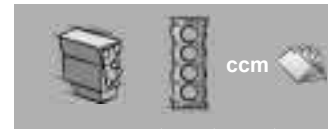









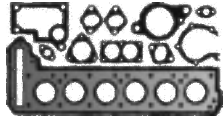
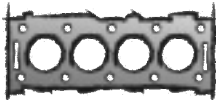

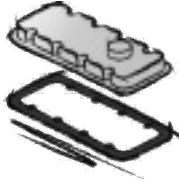









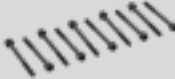
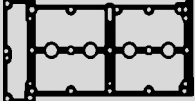







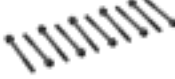
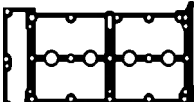









AR 37203	4	1598	18
AR 38201	4	1598	18
AR 38401	4	1747	20
AR 38501	4	1370	14
AR 67106	4	1747	20
AR 67199	4	1747	20
AR 67204	4	1970	38
AR 67299	4	1970	38
AR 67501	4	1929	32
AR 67601	4	1598	18
EC2	4	1995	38
M 722 BT 24.T	5	2387	40
VM 07 B	4	2499	42
VM 08 B	4	2499	42
VM 31 B	4	2499	44
VM 32 B	4	2499	44
VM4HT 2.4	4	2393	42
VM 81 A	4	2393	42
VM 84 A	4	2499	42

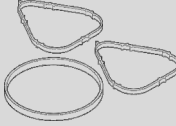

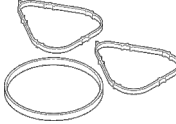







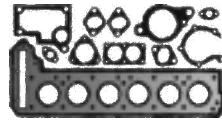
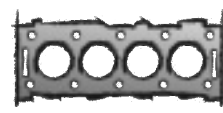

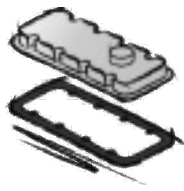

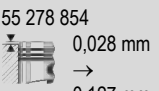



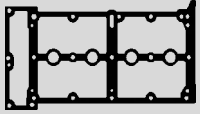

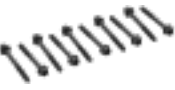



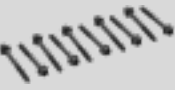

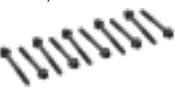



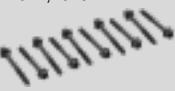
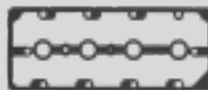









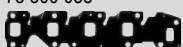

ALFA ROMEO







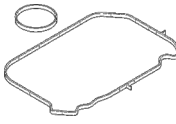



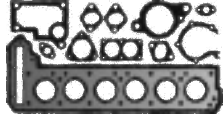
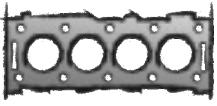



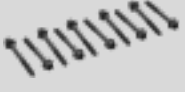
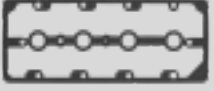

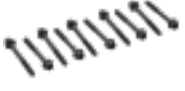
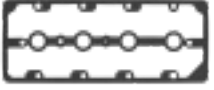

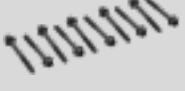
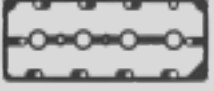

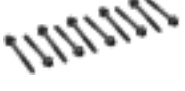
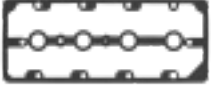







<p>ALFA ROMEO</p> 				
<p>199 B6.000</p> <p>2 Cyl. 875 ccm Cyl. 80,5 Ø</p> <p>Mito 04/2013 → 08/2018</p>	<p>ES⊕ 925.990 CS* 299.401 OKS 888.410 55 224 603</p>	<p>816.160 ● 55 254 545</p> 	<p>ZKS 949.350 55225419 (6x) M 9x1,25x120</p>	<p>ZKHS 707.120</p>
<p>312 A2.000</p> <p>2 Cyl. 875 ccm Cyl. 80,5 Ø</p> <p>Mito 07/2011 → 12/2013</p>	<p>ES⊕ 047.221 Euro 5 CS* 299.401 OKS 888.410 55 224 603</p>	<p>655.980 55 229 635 0,72 mm $\frac{1}{16}$ 82,7 Ø</p> 	<p>ZKS 949.350 55225419 (6x) M 9x1,25x120</p>	<p>ZKHS 005.660</p> 
<p>199 A3.000</p> <p>4 Cyl. 1248 ccm Cyl. 69,6 Ø</p> <p>Mito Multijet 08/2008 → 08/2010</p>	<p>ES⊕ 789.900 71 753 908</p>  <p>CS* 452.150 71 744 286</p>	<p>076.348 55 278 854  0,028 mm → 0,127 mm 0,72 mm $\frac{1}{16}$ 70,6 Ø</p> <p>076.358 55 278 855  0,128 mm → 0,227 mm 0,82 mm $\frac{1}{16}$ 70,6 Ø 1 ⊗</p> <p>076.408 55 278 856  0,228 mm → 0,327 mm 0,92 mm $\frac{1}{16}$ 70,6 Ø 2 ⊗</p>   	<p>ZKS 374.240 55 192 265 (10x) M 10x1,25x119</p> 	<p>074.173 73 500 063</p> 
<p>199 B1.000 199 B4.000 199 B8.000</p> <p>4 Cyl. 1248 ccm Cyl. 69,6 Ø</p> <p>Mito Multijet 09/2009 → 10/2018</p>	<p>ES⊕ 789.900 71 753 908</p>  <p>CS* 397.470 71 753 767</p>	<p>076.348 55 278 854  0,028 mm → 0,127 mm 0,72 mm $\frac{1}{16}$ 70,6 Ø</p> <p>076.358 55 278 855  0,128 mm → 0,227 mm 0,82 mm $\frac{1}{16}$ 70,6 Ø 1 ⊗</p> <p>076.408 55 278 856  0,228 mm → 0,327 mm 0,92 mm $\frac{1}{16}$ 70,6 Ø 2 ⊗</p>   	<p>ZKS 374.240 55 192 265 (10x) M 10x1,25x119</p> 	<p>074.173 73 500 063</p> 



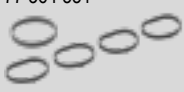
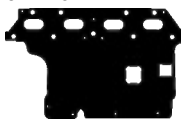
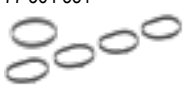







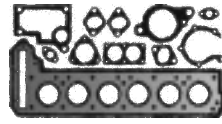
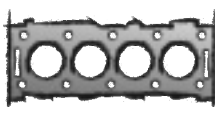

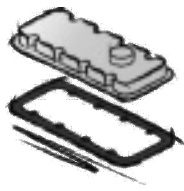
			<p>a) </p> <p>b) </p>	<p>K: </p> <p>N: </p>	
VAS 710.840 FPM	912.980 55 246 658 	AAS 008.170 77 365 787 	<p>a) 030.793 Dirko HT</p> <p>b) 878.110 incl. 110.604 55 184 773 M 12x1,25x13</p> <p>b) 110.604 2340.32.233 CU A 12x16x1,5</p>	<p>K:← 069.590 71 741 016 AW/BS RD FPM 31x41x7</p> <p>K:→ 135.110 55 229 956 ASW LD FPM/ACM 85x105x9</p>	
VAS 710.840 FPM	574.630 55 230 477 	AAS 008.170 77 365 787 	<p>a) 030.793 Dirko HT</p> <p>b) 878.110 incl. 110.604 55 184 773 M 12x1,25x13</p> <p>b) 110.604 2340.32.233 CU A 12x16x1,5</p>	<p>K:← 069.590 71 741 016 AW/BS RD FPM 31x41x7</p> <p>K:→ 135.110 55 229 956 ASW LD FPM/ACM 85x105x9</p>	TLS 002.360
VAS 445.100 46 556 651 FPM	431.310 73 500 058 	718.200 71 749 369 4x 	<p>a) 030.793 Dirko HT</p> <p>b) 274.410 46 823 509 M 14x1,5x13,5</p>	<p>K:← 445.060 55 186 757 AW/BS RD FPM 40x52x7</p> <p>K:→ 428.970 55 180 937 ASW LD PTFE/ACM 78x100x9</p>	 TLS 716.760
VAS 445.100 46 556 651 FPM	431.310 73 500 058 	718.200 71 749 369 4x 	<p>a) 030.793 Dirko HT</p> <p>b) 274.410 46 823 509 M 14x1,5x13,5</p>	<p>K:← 445.060 55 186 757 AW/BS RD FPM 40x52x7</p> <p>K:→ 428.970 55 180 937 ASW LD PTFE/ACM 78x100x9</p>	 TLS 007.810

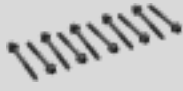
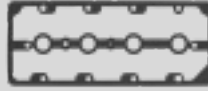
<p>ALFA ROMEO</p> 				
<p>330 A1.000 955 B2.000</p> <p>4 Cyl. 1248 ccm Cyl. 69,6 Ø</p> <p>Mito Multijet 08/2008 → 10/2018</p>	<p>ES⊕ 705.100</p>  <p>CS* 705.140 Euro 6</p>	<p>076.348 55 278 854</p>  <p>0,028 mm → 0,127 mm</p> <p>0,72 mm $\frac{3}{8}$ 70,6 Ø</p> <p>076.358 55 278 855</p>  <p>0,128 mm → 0,227 mm</p> <p>0,82 mm $\frac{3}{8}$ 70,6 Ø 1 ⊗</p> <p>076.408 55 278 856</p>  <p>0,228 mm → 0,327 mm</p> <p>0,92 mm $\frac{3}{8}$ 70,6 Ø 2 ⊗</p>	<p>ZKS 374.240 55 192 265 (10x) M 10x1,25x119</p> 	<p>074.173 73 500 063</p> 
<p>198 A1.000</p> <p>4 Cyl. 1368 ccm Cyl. 72,0 Ø</p> <p>Mito 09/2008 → 06/2011</p>	<p>ES⊕ 334.690 71 749 165 +55 195 339</p>  <p>CS* 309.990</p>	<p>344.671 55 206 232</p>  <p>0,72 mm $\frac{3}{8}$ 72,4 Ø</p>	<p>ZKS 111.590 7795992 (10x) M 9x1,25x87</p> 	<p>199.010 55 194 045</p> 
<p>198 A4.000</p> <p>4 Cyl. 1368 ccm Cyl. 72,0 Ø</p> <p>Giulietta 04/2010 → 12/2020</p> <p>Mito 08/2008 → 10/2018</p>	<p>ES⊕ 334.690 71 749 165 +55 195 339</p>  <p>CS* 309.990</p>	<p>344.671 55 206 232</p>  <p>0,72 mm $\frac{3}{8}$ 72,4 Ø</p>	<p>ZKS 111.590 7795992 (10x) M 9x1,25x87</p> 	<p>199.010 55 194 045</p> 
<p>199 A6.000 955 A1.000</p> <p>4 Cyl. 1368 ccm Cyl. 72,0 Ø</p> <p>Mito 08/2008 → 08/2013</p>	<p>ES⊕ 735.230 71 745 446</p> <p>CS* 309.990</p>	<p>344.661 55 202 800</p>  <p>0,49 mm $\frac{3}{8}$ 72,4 Ø</p>	<p>ZKS 111.590 7795992 (10x) M 9x1,25x87</p> 	<p>199.010 55 194 045</p> 
<p>199 A8.000</p> <p>4 Cyl. 1368 ccm Cyl. 72,0 Ø</p> <p>Mito 08/2008 → 06/2011</p>	<p>ES⊕ 334.690 71 749 165 +55 195 339</p>  <p>CS* 309.990</p>	<p>344.671 55 206 232</p>  <p>0,72 mm $\frac{3}{8}$ 72,4 Ø</p>	<p>ZKS 111.590 7795992 (10x) M 9x1,25x87</p> 	<p>199.010 55 194 045</p> 

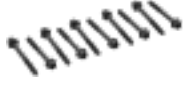
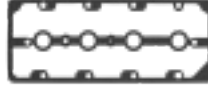

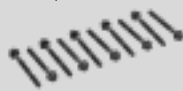
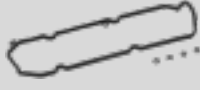







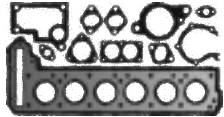
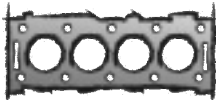

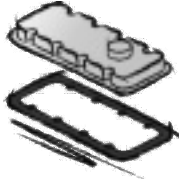



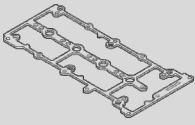

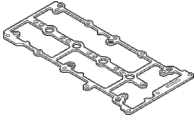

			<p>a) </p> <p>b) </p>	<p>K: </p> <p>N: </p>	
<p>VAS 445.100 46 556 651 FPM</p>	<p>431.310 73 500 058 </p>	<p>718.200 71 749 369 4x </p>	<p>a) 030.793 Dirko HT</p> <p>b) 274.410 46 823 509 M 14x1,5x13,5</p>	<p>K:← 445.060 55 186 757 AW/BS RD FPM 40x52x7</p> <p>K:→ 428.970 55 180 937 ASW LD PTFE/ACM 78x100x9</p>	TLS 705.300
<p>069.630 46 470 334 FPM 16x</p>	<p>344.720 55 210 321 </p>	<p>AAS 334.670 77 364 551 </p>	<p>a) 030.793 Dirko HT</p> <p>b) 878.110 incl. 110.604 55 184 773 M 12x1,25x13</p> <p>b) 110.604 2340.32.233 CU A 12x16x1,5</p>	<p>K:← 069.540 71 740 681 AW/BS RD FPM 27x37x7</p> <p>K:→ 375.320 46 539 824 SP LD FPM 74</p> <p>N:← 290.710 55 236 852 AW/BS RD FPM 40x55x7</p>	TLS 796.230 
<p>069.630 46 470 334 FPM 16x</p>	<p>344.720 55 210 321 </p> <p>514.161 </p>	<p>AAS 334.670 77 364 551 </p>	<p>a) 030.793 Dirko HT</p> <p>b) 878.110 incl. 110.604 55 184 773 M 12x1,25x13</p> <p>b) 110.604 2340.32.233 CU A 12x16x1,5</p>	<p>K:← 069.540 71 740 681 AW/BS RD FPM 27x37x7</p> <p>K:→ 375.320 46 539 824 SP LD FPM 74</p> <p>N:← 290.710 55 236 852 AW/BS RD FPM 40x55x7</p>	TLS 796.230 
<p>069.630 46 470 334 FPM 16x</p>	<p>339.260 46 526 271 </p>	<p>AAS 730.310 77 364 149 </p>	<p>a) 030.793 Dirko HT</p> <p>b) 878.110 incl. 110.604 55 184 773 M 12x1,25x13</p> <p>b) 110.604 2340.32.233 CU A 12x16x1,5</p>	<p>K:← 069.540 71 740 681 AW/BS RD FPM 27x37x7</p> <p>K:→ 375.320 46 539 824 SP LD FPM 74</p> <p>N:← 290.710 55 236 852 AW/BS RD FPM 40x55x7</p>	
<p>069.630 46 470 334 FPM 16x</p>	<p>344.720 55 210 321 </p>	<p>AAS 334.670 77 364 551 </p>	<p>a) 030.793 Dirko HT</p> <p>b) 878.110 incl. 110.604 55 184 773 M 12x1,25x13</p> <p>b) 110.604 2340.32.233 CU A 12x16x1,5</p>	<p>K:← 069.540 71 740 681 AW/BS RD FPM 27x37x7</p> <p>K:→ 375.320 46 539 824 SP LD FPM 74</p> <p>N:← 290.710 55 236 852 AW/BS RD FPM 40x55x7</p>	TLS 940.450



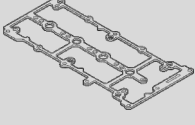





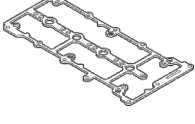







<p>ALFA ROMEO</p> 				
<p>940 A6.000 940 B1.000 940 B8.000</p> <p>4 Cyl. 1368 ccm Cyl. 72,0 Ø</p> <p>Giulietta 04/2010 → 02/2017</p>	<p>ES⊕ 334.690 71 749 165 +55 195 339</p>  <p>CS* 309.990</p>	<p>344.671 55 206 232 0,72 mm $\frac{1}{4}$ 72,4 Ø</p> 	<p>ZKS 111.590 7795992 (10x) M 9x1,25x87</p> 	<p>199.010 55 194 045</p> 
<p>940 B7.000</p> <p>4 Cyl. 1368 ccm Cyl. 72,0 Ø</p> <p>Giulietta 04/2010 → 12/2020</p>	<p>ES⊕ 928.770 CS* 309.990</p>	<p>344.671 55 206 232 0,72 mm $\frac{1}{4}$ 72,4 Ø</p> 	<p>ZKS 111.590 7795992 (10x) M 9x1,25x87</p> 	<p>199.010 55 194 045</p> 
<p>940 C2.000</p> <p>4 Cyl. 1368 ccm Cyl. 72,0 Ø</p> <p>Giulietta 09/2014 → 01/2020</p>	<p>ES⊕ 944.220 CS 928.790</p>	<p>344.671 55 206 232 0,72 mm $\frac{1}{4}$ 72,4 Ø</p> 	<p>ZKS 111.590 7795992 (10x) M 9x1,25x87</p> 	<p>ZKHS 944.170 199.010 55 194 045</p>  <p>944.000 55 233 643</p>  <p>939.400 55 233 644 4x</p>
<p>955 A2.000 955 A7.000 955 B1.000</p> <p>4 Cyl. 1368 ccm Cyl. 72,0 Ø</p> <p>Mito 10/2009 → 10/2018</p>	<p>ES⊕ 944.190 CS 928.760</p>	<p>344.671 55 206 232 0,72 mm $\frac{1}{4}$ 72,4 Ø</p> 	<p>ZKS 111.590 7795992 (10x) M 9x1,25x87</p> 	<p>ZKHS 944.170 199.010 55 194 045</p>  <p>944.000 55 233 643</p>  <p>939.400 55 233 644 4x</p>











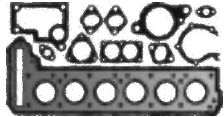
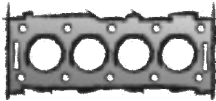

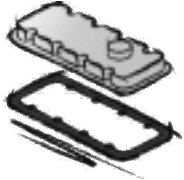
			<p>a) </p> <p>b) </p>	<p>K: </p> <p>N: </p>	
<p>069.630 46 470 334 FPM 16x</p>	<p>344.720 55 210 321</p> 	<p>AAS 334.670 77 364 551</p> 	<p>a) 030.793 Dirko HT</p> <p>b) 878.110 incl. 110.604 55 184 773 M 12x1,25x13</p> <p>b) 110.604 2340.32.233 CU A 12x16x1,5</p>	<p>K:← 069.540 71 740 681 AW/BS RD FPM 27x37x7</p> <p>K:→ 375.320 46 539 824 SP LD FPM 74</p> <p>N:← 290.710 55 236 852 AW/BS RD FPM 40x55x7</p>	
<p>069.630 46 470 334 FPM 16x</p>	<p>514.161</p> 	<p>AAS 334.670 77 364 551</p> 	<p>a) 030.793 Dirko HT</p> <p>b) 878.110 incl. 110.604 55 184 773 M 12x1,25x13</p> <p>b) 110.604 2340.32.233 CU A 12x16x1,5</p>	<p>K:← 069.540 71 740 681 AW/BS RD FPM 27x37x7</p> <p>K:→ 375.320 46 539 824 SP LD FPM 74</p> <p>N:← 290.710 55 236 852 AW/BS RD FPM 40x55x7</p>	<p>TLS 796.230</p> 
<p>069.630 46 470 334 FPM 16x</p>	<p>718.411 55 278 507</p> 	<p>AAS 334.670 77 364 551</p> 	<p>a) 030.793 Dirko HT</p> <p>b) 878.110 incl. 110.604 55 184 773 M 12x1,25x13</p> <p>b) 110.604 2340.32.233 CU A 12x16x1,5</p>	<p>K:← 069.540 71 740 681 AW/BS RD FPM 27x37x7</p> <p>K:→ 375.320 46 539 824 SP LD FPM 74</p> <p>N:← 688.580 55 189 997 AW/BS RD FPM 31x55x7</p>	
<p>069.630 46 470 334 FPM 16x</p>	<p>514.192 55 225 376</p> 	<p>AAS 334.670 77 364 551</p> 	<p>a) 030.793 Dirko HT</p> <p>b) 878.110 incl. 110.604 55 184 773 M 12x1,25x13</p> <p>b) 110.604 2340.32.233 CU A 12x16x1,5</p>	<p>K:← 069.540 71 740 681 AW/BS RD FPM 27x37x7</p> <p>K:→ 375.320 46 539 824 SP LD FPM 74</p> <p>N:← 688.580 55 189 997 AW/BS RD FPM 31x55x7</p>	

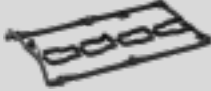















<p>ALFA ROMEO</p> 				
<p>955 A6.000</p> <p>4 Cyl. 1368 ccm Cyl. 72,0 Ø</p> <p>Mito 09/2009 → 08/2013</p>	<p>CS* 309.990</p>	<p>344.661 55 202 800 0,49 mm $\frac{\pm}{\pm}$ 72,4 Ø</p> 	<p>ZKS 111.590 7795992 (10x) M 9x1,25x87</p> 	<p>ZKHS 944.170 199.010 55 194 045</p>  <p>944.000 55 233 643</p>  <p>939.400 55 233 644 4x</p>
<p>940 A2.000 955 A8.000</p> <p>4 Cyl. 1368 ccm Cyl. 72,0 Ø</p> <p>Giulietta 04/2010 → 12/2020</p> <p>Mito 09/2009 → 10/2018</p>	<p>ES⊕ 944.190 Mito 955</p> <p>ES⊕ 944.220 Giulietta 940</p> <p>CS 928.760 Mito 955</p> <p>CS 928.790 Giulietta 940</p>	<p>344.671 55 206 232 0,72 mm $\frac{\pm}{\pm}$ 72,4 Ø</p> 	<p>ZKS 111.590 7795992 (10x) M 9x1,25x87</p> 	<p>ZKHS 944.170 199.010 55 194 045</p>  <p>944.000 55 233 643</p>  <p>939.400 55 233 644 4x</p>
<p>350 A1.000 955 A9.000</p> <p>4 Cyl. 1368 ccm Cyl. 72,0 Ø</p> <p>Mito 03/2011 → 10/2018</p>	<p>ES⊕ 037.461 71 740 655</p> <p>CS* 431.560 71 736 317</p>	<p>040.554 55 189 950 0,49 mm $\frac{\pm}{\pm}$ 72,4 Ø</p> 	<p>ZKS 760.720 7696197 (10x) M 9x1,25x96</p> 	<p>ZKHS 724.280</p>  <p>505.060 71 740 678</p> 
<p>AR 33503/38501</p> <p>4 Cyl. 1370 ccm Cyl. 82,0 Ø</p> <p>Alfa 145 12/1996 → 01/2001</p> <p>Alfa 146 11/1996 → 01/2001</p>	<p>S⊕* 180.500 71 711 736 →05/1998</p> <p>ES⊕ 180.520 71 711 735 →05/1998</p> <p>ES⊕ 180.540 71 713 629 05/1998→</p>	<p>180.490 60 616 864 1,20 mm $\frac{\pm}{\pm}$ 83 Ø</p> 		<p>ZKHS 199.020 60 607 218 +60 607 219 →05/1998</p>  <p>199.080 60 655 592 05/1998→</p> 











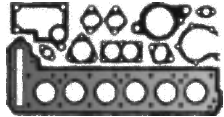
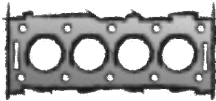

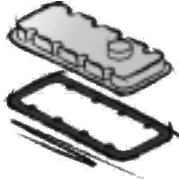



			<p>a) </p> <p>b) </p>	<p>K: </p> <p>N: </p>	
<p>069.630 46 470 334 FPM 16x</p>	<p>339.260 46 526 271</p>	<p>AAS 689.940</p>	<p>a) 030.793 Dirko HT</p> <p>b) 878.110 incl. 110.604 55 184 773 M 12x1,25x13</p> <p>b) 110.604 2340.32.233 CU A 12x16x1,5</p>	<p>K:← 069.540 71 740 681 AW/BS RD FPM 27x37x7</p> <p>K:→ 375.320 46 539 824 SP LD FPM 74</p> <p>N:← 688.580 55 189 997 AW/BS RD FPM 31x55x7</p>	
<p>069.630 46 470 334 FPM 16x</p>	<p>514.192 55 225 376 Mito 955</p> <p>718.411 55 278 507 Giulietta 940</p>	<p>AAS 334.670 77 364 551</p>	<p>a) 030.793 Dirko HT</p> <p>b) 878.110 incl. 110.604 55 184 773 M 12x1,25x13</p> <p>b) 110.604 2340.32.233 CU A 12x16x1,5</p>	<p>K:← 069.540 71 740 681 AW/BS RD FPM 27x37x7</p> <p>K:→ 375.320 46 539 824 SP LD FPM 74</p> <p>N:← 688.580 55 189 997 AW/BS RD FPM 31x55x7</p>	
<p>VAS 688.050 FPM</p> <p>476.691 55 190 344 FPM 8x</p>	<p>375.070 55 199 355</p>	<p>AAS 444.760 77 363 787</p>	<p>a) 030.793 Dirko HT</p> <p>b) 587.100 7734022 M 22x1,5x13</p>	<p>K:← 069.540 71 740 681 AW/BS RD FPM 27x37x7</p> <p>K:→ 069.600 71 754 491 AW/BS LD FPM 74x88x8</p> <p>N:← 290.710 55 236 852 AW/BS RD FPM 40x55x7</p>	
<p>VAS 825.042 FPM 2x</p> <p>701.289 46 440 885 FPM 16x</p>	<p>448.510 73 502 761</p>	<p>373.450 60 659 746</p>	<p>a) 030.793 Dirko HT</p> <p>a) 365.020 60 626 642</p> <p>b) 877.920 incl. 339.580 60 813 578 M 18x1,5x22</p> <p>b) 339.580 55 196 309 CU A 18x26x1,5</p>	<p>K:← 069.590 71 741 016 AW/BS RD FPM 31x41x7</p> <p>K:→ 199.191 71 718 365 SP LD FPM 93x12</p> <p>N:← 477.010 60 603 436 AW/BS RD FPM 55x68x8</p> <p>N:← 505.838 71 753 052 ASW RD FPM 30x42x7</p>	



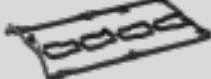











ALFA ROMEO 				
552 80 444 4 Cyl. 1598 ccm Cyl. 79,5 Ø Giulietta JTDM 02/2015 → 12/2020		789.180 55 221 093 0,82 mm $\frac{+}{-}$ 80,5 Ø  789.190 55 221 094 0,92 mm $\frac{+}{-}$ 80,5 Ø  1 ⊗ 789.200 55 221 095 1,02 mm $\frac{+}{-}$ 80,5 Ø  2 ⊗	ZKS 524.160 55 214 378 (10x) M 12x1,25x98 	748.591 55 205 111 
940 A3.000 4 Cyl. 1598 ccm Cyl. 79,5 Ø Giulietta JTDM 04/2010 → 02/2016		789.180 55 221 093 0,82 mm $\frac{+}{-}$ 80,5 Ø  789.190 55 221 094 0,92 mm $\frac{+}{-}$ 80,5 Ø  1 ⊗ 789.200 55 221 095 1,02 mm $\frac{+}{-}$ 80,5 Ø  2 ⊗	ZKS 524.160 55 214 378 (10x) M 12x1,25x98 	748.591 55 205 111 
940 C1.000 940 C5.000 4 Cyl. 1598 ccm Cyl. 79,5 Ø Giulietta JTDM 02/2015 → 12/2020		789.180 55 221 093 0,82 mm $\frac{+}{-}$ 80,5 Ø  789.190 55 221 094 0,92 mm $\frac{+}{-}$ 80,5 Ø  1 ⊗ 789.200 55 221 095 1,02 mm $\frac{+}{-}$ 80,5 Ø  2 ⊗	ZKS 524.160 55 214 378 (10x) M 12x1,25x98 	748.591 55 205 111 
198 A2.000 955 A3.000 955 A4.000 4 Cyl. 1598 ccm Cyl. 79,5 Ø Mito JTDM 08/2008 → 08/2015	ES⊕ 399.870 71 769 851 Mot. 6491051→  CS* 592.910 71749743 71 749 743 +71718365	789.180 55 221 093 0,82 mm $\frac{+}{-}$ 80,5 Ø  789.190 55 221 094 0,92 mm $\frac{+}{-}$ 80,5 Ø  1 ⊗ 789.200 55 221 095 1,02 mm $\frac{+}{-}$ 80,5 Ø  2 ⊗	ZKS 524.160 55 214 378 (10x) M 12x1,25x98 	748.591 55 205 111 





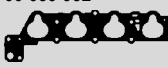

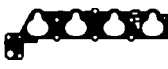



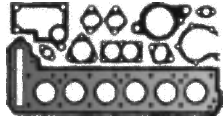
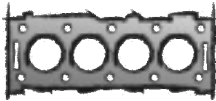

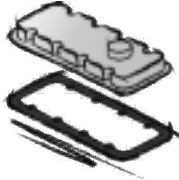

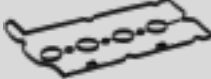
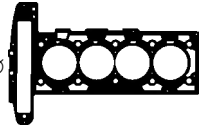



			<p>a) </p> <p>b) </p>	<p>K: </p> <p>N: </p>	
<p>506.550 55 183 812 FPM 16x</p>	<p>907.400 Euro 6</p> 	<p>AAS 340.470 71 754 211</p> 	<p>a) 030.793 Dirko HT</p> <p>b) 877.920 incl. 339.580 60 813 578 M 18x1,5x22</p> <p>b) 878.030 incl. 359.300 55 196 505 M 18x1,5x20</p> <p>b) 339.580 55 196 309 CU A 18x26x1,5</p> <p>b) 359.300 FPM A 18x26x1,5 FE/FPM</p>	<p>K:← 069.590 71 741 016 AW/BS RD FPM 31x41x7</p> <p>K:→ 199.191 71 718 365 SP LD FPM 93x12</p> <p>N:← 434.500 46 802 577 A/BS RD FPM 30x45x7</p>	<p>TLS 651.340</p>
<p>506.550 55 183 812 FPM 16x</p>	<p>748.510 55 210 879</p> 	<p>AAS 340.470 71 754 211</p> 	<p>a) 030.793 Dirko HT</p> <p>b) 877.920 incl. 339.580 60 813 578 M 18x1,5x22</p> <p>b) 878.030 incl. 359.300 55 196 505 M 18x1,5x20</p> <p>b) 339.580 55 196 309 CU A 18x26x1,5</p> <p>b) 359.300 FPM A 18x26x1,5 FE/FPM</p>	<p>K:← 069.590 71 741 016 AW/BS RD FPM 31x41x7</p> <p>K:→ 199.191 71 718 365 SP LD FPM 93x12</p> <p>N:← 434.500 46 802 577 A/BS RD FPM 30x45x7</p>	
<p>506.550 55 183 812 FPM 16x</p>	<p>907.400 Euro 6</p> 	<p>AAS 340.470 71 754 211</p> 	<p>a) 030.793 Dirko HT</p> <p>b) 877.920 incl. 339.580 60 813 578 M 18x1,5x22</p> <p>b) 878.030 incl. 359.300 55 196 505 M 18x1,5x20</p> <p>b) 339.580 55 196 309 CU A 18x26x1,5</p> <p>b) 359.300 FPM A 18x26x1,5 FE/FPM</p>	<p>K:← 069.590 71 741 016 AW/BS RD FPM 31x41x7</p> <p>K:→ 199.191 71 718 365 SP LD FPM 93x12</p> <p>N:← 434.500 46 802 577 A/BS RD FPM 30x45x7</p>	
<p>506.550 55 183 812 FPM 16x</p>	<p>748.510 55 210 879</p> 	<p>AAS 340.470 71 754 211</p> 	<p>a) 030.793 Dirko HT</p> <p>b) 877.920 incl. 339.580 60 813 578 M 18x1,5x22</p> <p>b) 878.030 incl. 359.300 55 196 505 M 18x1,5x20</p> <p>b) 339.580 55 196 309 CU A 18x26x1,5</p> <p>b) 359.300 FPM A 18x26x1,5 FE/FPM</p>	<p>K:← 069.590 71 741 016 AW/BS RD FPM 31x41x7</p> <p>K:→ 199.191 71 718 365 SP LD FPM 93x12</p> <p>N:← 434.500 46 802 577 A/BS RD FPM 30x45x7</p>	









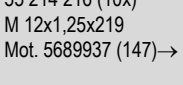
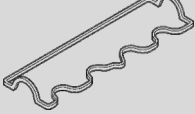
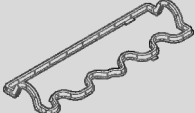







ALFA ROMEO 				
AR 32102 4 Cyl. 1598 ccm Cyl. 82,0 Ø Alfa 145 09/1997 → 12/2000 Alfa 146 09/1997 → 12/2000 Alfa 156 09/1997 → 05/2006	S⊕* 710.451 71 713 632 ES⊕ 710.461 71 713 631	710.440 60 812 490 83 Ø 	ZKS 152.080 7710582 (10x) M 10x1,25x254 	199.080 60 655 592 
AR 32103/32104 4 Cyl. 1598 ccm Cyl. 82,0 Ø Alfa 147 01/2001 → 03/2010 Alfa 156 09/1997 → 05/2006	S⊕* 180.570 71 717 686 ES⊕ 180.600 71 717 685 CS* 431.250 71 719 779	626.727 60 664 642 0,49 mm $\frac{2}{3}$ 84 Ø 		199.080 60 655 592 
AR 37203 4 Cyl. 1598 ccm Cyl. 82,0 Ø Alfa 147 01/2001 → 03/2010	S⊕* 180.570 71 717 686 ES⊕ 180.600 71 717 685 CS* 431.250 71 719 779	626.727 60 664 642 0,49 mm $\frac{2}{3}$ 84 Ø 		199.080 60 655 592 
AR 38201/67601 4 Cyl. 1598 ccm Cyl. 82,0 Ø Alfa 145 12/1996 → 01/2001 Alfa 146 11/1996 → 10/2001 Alfa 155 05/1996 → 12/1997 Alfa 156 09/1997 → 05/2006	S⊕* 710.451 71 713 632 05/1998→ ES⊕ 372.500 71 711 023 →05/1998 ES⊕ 710.461 71 713 631 05/1998→	710.440 60 812 490 83 Ø 	ZKS 152.080 7710582 (10x) M 10x1,25x254 	ZKHS 199.020 60 607 218 +60 607 219 →05/1998  199.080 60 655 592 05/1998→ 

			<p>a) </p> <p>b) </p>	<p>K: </p> <p>N: </p>	
<p>VAS 825.042 FPM 2x 701.289 46 440 885 FPM 16x</p>	<p>448.510 73 502 761 </p>	<p>685.150 60 659 952 </p>	<p>a) 030.793 Dirko HT a) 365.020 60 626 642 b) 877.920 incl. 339.580 60 813 578 M 18x1,5x22 b) 339.580 55 196 309 CU A 18x26x1,5</p>	<p>K:← 069.590 71 741 016 AW/BS RD FPM 31x41x7 K:→ 199.191 71 718 365 SP LD FPM 93x12 N:← 477.010 60 603 436 AW/BS RD FPM 55x68x8 N:← 505.838 71 753 052 ASW RD FPM 30x42x7</p>	
<p>VAS 825.042 FPM 2x 701.289 46 440 885 FPM 16x</p>	<p>448.510 73 502 761 </p>	<p>685.150 60 659 952 </p>	<p>a) 030.793 Dirko HT a) 365.020 60 626 642 →Mot. 3840485 b) 877.920 incl. 339.580 60 813 578 M 18x1,5x22 b) 339.580 55 196 309 CU A 18x26x1,5</p>	<p>K:← 069.590 71 741 016 AW/BS RD FPM 31x41x7 K:→ 199.191 71 718 365 SP LD FPM 93x12 N:← 477.010 60 603 436 AW/BS RD FPM 55x68x8 N:← 505.838 71 753 052 ASW RD FPM 30x42x7</p>	
<p>VAS 825.042 FPM 2x 701.289 46 440 885 FPM 16x</p>	<p>448.510 73 502 761 </p>	<p>373.450 60 659 746 </p>	<p>a) 030.793 Dirko HT a) 365.020 60 626 642 b) 877.920 incl. 339.580 60 813 578 M 18x1,5x22 b) 339.580 55 196 309 CU A 18x26x1,5</p>	<p>K:← 069.590 71 741 016 AW/BS RD FPM 31x41x7 K:→ 199.191 71 718 365 SP LD FPM 93x12 N:← 477.010 60 603 436 AW/BS RD FPM 55x68x8 N:← 505.838 71 753 052 ASW RD FPM 30x42x7</p>	
<p>VAS 825.042 FPM 2x 701.289 46 440 885 FPM 16x</p>	<p>448.510 73 502 761 </p>	<p>685.150 60 659 952 </p>	<p>a) 030.793 Dirko HT a) 365.020 60 626 642 b) 877.920 incl. 339.580 60 813 578 M 18x1,5x22 b) 339.580 55 196 309 CU A 18x26x1,5</p>	<p>K:← 069.590 71 741 016 AW/BS RD FPM 31x41x7 K:→ 199.191 71 718 365 SP LD FPM 93x12 N:← 477.010 60 603 436 AW/BS RD FPM 55x68x8 N:← 505.838 71 753 052 ASW RD FPM 30x42x7</p>	

<p>ALFA ROMEO</p> 				
<p>939 B1.000 940 A1.000</p> <p>4 Cyl. 1742 ccm Cyl. 83,0 Ø</p> <p>Alfa 159 05/2009 → 12/2012</p> <p>Brera 05/2009 → 06/2010</p> <p>Giulietta 04/2010 → 02/2016</p> <p>Spider 05/2009 → 03/2011</p>	<p>ES⊕ 814.140</p>  <p>CS* 822.430</p>	<p>492.252 55 215 398 0,64 mm $\frac{\pm}{\text{mm}}$ 83,7 Ø</p> 	<p>ZKS 445.680 55214072 (10x) M 10x1,25x250</p>	<p>461.682 EL-Liq 74 308.210 55 215 302 ↑</p> 
<p>940 B2.000 960 A1.000</p> <p>4 Cyl. 1742 ccm Cyl. 83,0 Ø</p> <p>4C 03/2013 → 12/2020</p> <p>Giulietta 09/2013 → 10/2018</p>	<p>ES⊕ 814.140</p> 	<p>006.522 55 255 995 0,79 mm $\frac{\pm}{\text{mm}}$ 83,7 Ø</p>		<p>461.682 EL-Liq 74 308.210 55 215 302 ↑</p> 
<p>AR 32201/38401</p> <p>4 Cyl. 1747 ccm Cyl. 82,0 Ø</p> <p>Alfa 145 12/1996 → 01/2001</p> <p>Alfa 146 11/1996 → 01/2001</p> <p>Alfa 156 09/1997 → 10/2000</p> <p>GTV 05/1998 → 10/2005</p> <p>Spider 05/1998 → 04/2005</p>	<p>S⊕* 710.451 71 713 632</p> <p>ES⊕ 710.461 71 713 631</p>	<p>710.440 60 812 490 83 Ø</p> 	<p>ZKS 152.080 7710582 (10x) M 10x1,25x254</p> 	<p>199.080 60 655 592</p> 
<p>AR 32205</p> <p>4 Cyl. 1747 ccm Cyl. 82,0 Ø</p> <p>Alfa 156 02/1997 → 05/2006</p> <p>GT 11/2003 → 09/2010</p>	<p>S⊕* 180.570 71 717 686</p> <p>ES⊕ 180.600 71 717 685</p> <p>CS* 431.250 71 719 779</p>	<p>626.727 60 664 642 0,49 mm $\frac{\pm}{\text{mm}}$ 84 Ø</p> 	<p>ZKS 152.080 7710582 (10x) M 10x1,25x254</p> 	<p>199.080 60 655 592</p> 
<p>AR 67106/67199</p> <p>4 Cyl. 1747 ccm Cyl. 82,0 Ø</p> <p>Alfa 145 12/1996 → 12/1998</p> <p>Alfa 146 11/1996 → 01/2001</p> <p>Alfa 155 05/1996 → 12/1997</p>	<p>ES⊕ 372.500 71 711 023</p>	<p>710.440 60 812 490 83 Ø</p> 	<p>ZKS 152.080 7710582 (10x) M 10x1,25x254</p> 	<p>ZKHS 199.020 60 607 218 +60 607 219</p> 









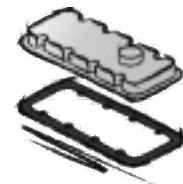
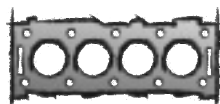
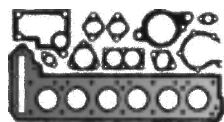



			<p>a) </p> <p>b) </p>	<p>K: </p> <p>N: </p>	
<p>332.330 46 743 167 FPM 16x</p>	<p>344.771 55 214 576</p> 		<p>a) 030.793 Dirko HT</p> <p>b) 877.920 incl. 339.580 60 813 578 M 18x1,5x22</p> <p>b) 339.580 55 196 309 CU A 18x26x1,5</p>	<p>K:← 069.590 71 741 016 AW/BS RD FPM 31x41x7</p> <p>K:→ 199.191 71 718 365 SP LD FPM 93x12</p> <p>N:← 290.710 55 236 852 AW/BS RD FPM 40x55x7 2x</p>	
<p>332.330 46 743 167 FPM 16x</p>	<p>344.771 55 214 576</p> 		<p>a) 030.793 Dirko HT</p> <p>b) 877.920 incl. 339.580 60 813 578 M 18x1,5x22</p> <p>b) 339.580 55 196 309 CU A 18x26x1,5</p>	<p>K:← 069.590 71 741 016 AW/BS RD FPM 31x41x7</p> <p>K:→ 199.191 71 718 365 SP LD FPM 93x12</p> <p>N:← 290.710 55 236 852 AW/BS RD FPM 40x55x7 2x</p>	
<p>VAS 825.042 FPM 2x</p> <p>701.289 46 440 885 FPM 16x</p>	<p>448.510 73 502 761</p> 	<p>685.150 60 659 952</p> 	<p>a) 030.793 Dirko HT</p> <p>a) 365.020 60 626 642</p> <p>b) 877.920 incl. 339.580 60 813 578 M 18x1,5x22</p> <p>b) 339.580 55 196 309 CU A 18x26x1,5</p>	<p>K:← 069.590 71 741 016 AW/BS RD FPM 31x41x7</p> <p>K:→ 199.191 71 718 365 SP LD FPM 93x12</p> <p>N:← 477.010 60 603 436 AW/BS RD FPM 55x68x8</p> <p>N:← 505.838 71 753 052 ASW RD FPM 30x42x7</p>	
<p>VAS 825.042 FPM 2x</p> <p>701.289 46 440 885 FPM 16x</p>	<p>448.510 73 502 761</p> 	<p>685.150 60 659 952</p> 	<p>a) 030.793 Dirko HT</p> <p>a) 365.020 60 626 642</p> <p>b) 877.920 incl. 339.580 60 813 578 M 18x1,5x22</p> <p>b) 339.580 55 196 309 CU A 18x26x1,5</p>	<p>K:← 069.590 71 741 016 AW/BS RD FPM 31x41x7</p> <p>K:→ 199.191 71 718 365 SP LD FPM 93x12</p> <p>N:← 477.010 60 603 436 AW/BS RD FPM 55x68x8</p> <p>N:← 505.838 71 753 052 ASW RD FPM 30x42x7</p>	
<p>VAS 825.042 FPM 2x</p> <p>701.289 46 440 885 FPM 16x</p>	<p>448.510 73 502 761</p> 	<p>685.150 60 659 952</p> 	<p>a) 030.793 Dirko HT</p> <p>a) 365.020 60 626 642</p> <p>b) 877.920 incl. 339.580 60 813 578 M 18x1,5x22</p> <p>b) 339.580 55 196 309 CU A 18x26x1,5</p>	<p>K:← 069.590 71 741 016 AW/BS RD FPM 31x41x7</p> <p>K:→ 199.191 71 718 365 SP LD FPM 93x12</p> <p>N:← 477.010 60 603 436 AW/BS RD FPM 55x68x8</p> <p>N:← 505.838 71 753 052 ASW RD FPM 30x42x7</p>	





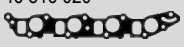





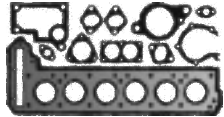
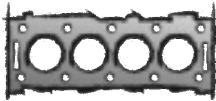

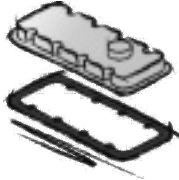



<p>ALFA ROMEO</p> 				
<p>939 A4.000</p> <p>4 Cyl. 1796 ccm Cyl. 80,5 Ø</p> <p>Alfa 159 06/2005 → 11/2011</p>	<p>ES⊕ 354.010 CS* 353.830 OKS 599.160</p> 	<p>076.892 71 744 395 0,65 mm $\frac{\pm}{\pm}$ 81,7 Ø</p> 		<p>354.030 55 354 237</p> 
<p>939 A6.000</p> <p>4 Cyl. 1859 ccm Cyl. 86,0 Ø</p> <p>Alfa 159 09/2005 → 11/2011</p>	<p>ES⊕ 926.710 CS* 382.130</p>	<p>151.611 55 192 574 0,64 mm $\frac{\pm}{\pm}$ 87 Ø</p> 	<p>ZKS 257.910 71 739 374 (10x) M 11x1,5x162</p>  <p>ZKS 509.710 71 739 374 (10x) M 11x1,5x162 / M 8</p> 	<p>ZKHS 926.700 55 189 690</p>
<p>182 B9.000</p> <p>4 Cyl. 1910 ccm Cyl. 82,0 Ø</p> <p>Alfa 147 JTD 06/2003 → 03/2010</p>	<p>S⊕* 180.000 60 816 452 →Mot. 4081110</p>  <p>ES⊕ 180.060 60 816 453 →Mot. 4081110</p>  <p>ES⊕ 498.980 71 739 971 Mot. 4081111→</p>  <p>CS 387.580 71 730 404</p>	<p>217.001 55 200 891</p>  <p>0,020 mm → 0,100 mm</p> <p>0,82 mm $\frac{\pm}{\pm}$ 83 Ø</p> <p>217.021 55 202 010</p>  <p>0,101 mm → 0,200 mm</p> <p>0,92 mm $\frac{\pm}{\pm}$ 83 Ø 1 ⊗</p> <p>217.031 55 202 011</p>  <p>0,201 mm → 0,295 mm</p> <p>1,02 mm $\frac{\pm}{\pm}$ 83 Ø 2 ⊗</p>   	<p>ZKS 152.440 7775920 (10x) M 12x1,25x218 →Mot. 5689936 (147)</p>  <p>ZKS 642.100 55 571 777 (10x) M 12x1,25x224,5 Mot. 5689937 (147)→</p>  <p>ZKS 687.330 55 214 216 (10x) M 12x1,25x219 Mot. 5689937 (147)→</p> 	<p>199.030 46 552 748 →Mot. 4081110</p>  <p>430.400 55 197 598 Mot. 4081111→</p> 

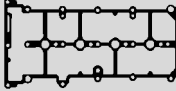







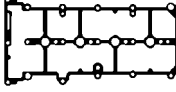



			<p>a) </p> <p>b) </p>	<p>K: </p> <p>N: </p>	
<p>061.760 71 739 773 FPM 16x</p>	<p>355.340 71 744 380</p> 	<p>AAS 207.210</p>  <p>434.350 71 744 413</p> 	<p>a) 030.793 Dirko HT</p> <p>b) 476.750 FPM RD 18x22x2</p>	<p>K:← 056.900 71 739 825 A/BS RD FPM 31,5x42x7</p> <p>K:→ 353.840 55 555 805 SP LD PTFE/ACM 80x98</p> <p>N:← 353.990 55 563 374 ASW RD FPM 35x48x7 2x</p>	
<p>VAS 538.080 FPM</p> <p>007.030 71 739 347 FPM 16x</p> 	<p>151.690 55 193 545</p>	<p>040.331 55 182 628</p> 	<p>a) 030.793 Dirko HT</p> <p>b) 823.400 71 739 255 M 12x1,75x17</p> <p>b) 056.130 71 739 194 FPM RD 10,8x20,8x2,6</p>	<p>K:← 127.610 71 739 386 ASW RD FPM/ACM 42x55x7</p> <p>K:→ 694.770 71 739 336 ASW LD FPM/ACM 90x104x11</p>	
<p>VAS 294.250 FPM</p> <p>294.110 60 513 469 FPM 8x</p>	<p>458.360 46 467 747</p> 	<p>879.280 60 816 179</p> 	<p>a) 030.793 Dirko HT</p> <p>b) 877.920 incl. 339.580 60 813 578 M 18x1,5x22</p> <p>b) 339.580 55 196 309 CU A 18x26x1,5</p>	<p>K:← 069.590 71 741 016 AW/BS RD FPM 31x41x7</p> <p>K:→ 199.191 71 718 365 SP LD FPM 93x12</p> <p>N:← 505.838 71 753 052 ASW RD FPM 30x42x7</p>	<p>TLS 434.310</p> 











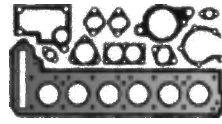
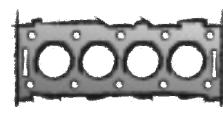

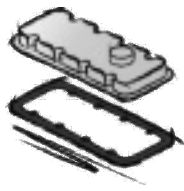





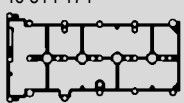





ALFA ROMEO

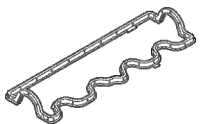





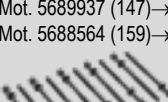
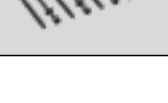





















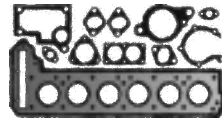
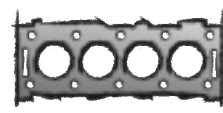

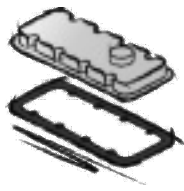







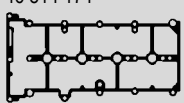



			<p>a) </p> <p>b) </p>	<p>K: </p> <p>N: </p>	
<p>VAS 332.470 FPM 332.330 46 743 167 FPM 16x</p>	<p>448.510 73 502 761 </p>	<p>439.000 46 816 020 </p>	<p>a) 030.793 Dirko HT</p> <p>b) 877.920 incl. 339.580 60 813 578 M 18x1,5x22</p> <p>b) 339.580 55 196 309 CU A 18x26x1,5</p>	<p>K:← 069.590 71 741 016 AW/BS RD FPM 31x41x7</p> <p>K:→ 199.191 71 718 365 SP LD FPM 93x12</p> <p>N:← 434.500 46 802 577 A/BS RD FPM 30x45x7</p>	<p>TLS 434.420 </p>
<p>VAS 294.250 FPM 294.110 60 513 469 FPM 8x</p>	<p>458.360 46 467 747 </p>	<p>879.280 60 816 179 </p>	<p>a) 030.793 Dirko HT</p> <p>b) 877.920 incl. 339.580 60 813 578 M 18x1,5x22</p> <p>b) 339.580 55 196 309 CU A 18x26x1,5</p>	<p>K:← 069.590 71 741 016 AW/BS RD FPM 31x41x7</p> <p>K:→ 199.191 71 718 365 SP LD FPM 93x12</p> <p>N:← 505.838 71 753 052 ASW RD FPM 30x42x7</p>	<p>TLS 434.420 </p>
Empty space for additional information or notes					









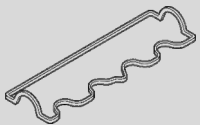
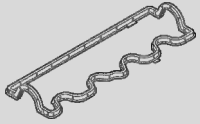







<p>ALFA ROMEO</p> 				
<p>192 B1.000 937 A4.000</p> <p>4 Cyl. 1910 ccm Cyl. 82,0 Ø</p> <p>Alfa 147 JTD 09/2003 → 03/2010</p> <p>Alfa 156 JTD 11/2002 → 05/2006</p>	<p>ES⊕ 491.980 71 730 214</p>  <p>CS 387.580 71 730 404</p>	<p>843.833 ● 55 195 892</p>  <p>→ 0,100 mm</p> <p>0,82 mm $\frac{+}{-}$ 83 Ø →05/2005</p> <p>217.052 55 200 890</p>  <p>→ 0,100 mm</p> <p>0,82 mm $\frac{+}{-}$ 83 Ø 05/2005→</p> <p>008.822 55 201 694</p>  <p>→ 0,101 mm → 0,200 mm</p> <p>0,92 mm $\frac{+}{-}$ 83 Ø 1 ⊗ 05/2005→</p> <p>008.832 55 201 695</p>  <p>→ 0,201 mm → 0,295 mm</p> <p>1,02 mm $\frac{+}{-}$ 83 Ø 2 ⊗ 05/2005→</p>	<p>ZKS 642.100 55 571 777 (10x) M 12x1,25x224,5</p>  <p>ZKS 687.330 55 214 216 (10x) M 12x1,25x219</p>	<p>875.350 46 814 174</p> 
<p>937 A5.000</p> <p>4 Cyl. 1910 ccm Cyl. 82,0 Ø</p> <p>Alfa 147 JTDM 09/2004 → 03/2010</p> <p>Alfa 156 JTD 07/2004 → 05/2006</p> <p>GT JTD 11/2003 → 09/2010</p>	<p>ES⊕ 491.980 71 730 214 →Mot. 5192515</p>  <p>ES⊕ 585.020 71 753 439 Mot. 5192516→</p>  <p>CS 387.580 71 730 404</p>	<p>843.833 ● 55 195 892</p>  <p>→ 0,100 mm</p> <p>0,82 mm $\frac{+}{-}$ 83 Ø →05/2005</p> <p>217.052 55 200 890</p>  <p>→ 0,100 mm</p> <p>0,82 mm $\frac{+}{-}$ 83 Ø 05/2005→</p> <p>008.822 55 201 694</p>  <p>→ 0,101 mm → 0,200 mm</p> <p>0,92 mm $\frac{+}{-}$ 83 Ø 1 ⊗ 05/2005→</p> <p>008.832 55 201 695</p>  <p>→ 0,201 mm → 0,295 mm</p> <p>1,02 mm $\frac{+}{-}$ 83 Ø 2 ⊗ 05/2005→</p>	<p>ZKS 642.100 55 571 777 (10x) M 12x1,25x224,5</p>  <p>ZKS 687.330 55 214 216 (10x) M 12x1,25x219</p>	<p>875.350 46 814 174</p> 











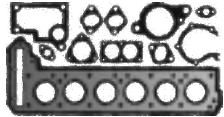
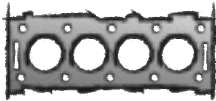

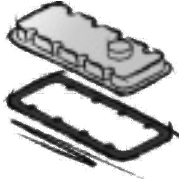



			<p>a) </p> <p>b) </p>	<p>K: </p> <p>N: </p>	
<p>VAS 332.470 FPM 332.330 46 743 167 FPM 16x</p>	<p>448.510 73 502 761 </p>	<p>439.000 46 816 020 </p>	<p>a) 030.793 Dirko HT b) 877.920 incl. 339.580 60 813 578 M 18x1,5x22 b) 339.580 55 196 309 CU A 18x26x1,5</p>	<p>K:← 069.590 71 741 016 AW/BS RD FPM 31x41x7 K:→ 199.191 71 718 365 SP LD FPM 93x12 N:← 434.500 46 802 577 A/BS RD FPM 30x45x7</p>	
<p>VAS 332.470 FPM →Mot. 5192515 332.330 46 743 167 FPM →Mot. 5192515 16x 506.550 55 183 812 FPM Mot. 5192516→ 16x</p>	<p>448.510 73 502 761 </p>	<p>439.000 46 816 020 </p>	<p>a) 030.793 Dirko HT b) 877.920 incl. 339.580 60 813 578 M 18x1,5x22 b) 339.580 55 196 309 CU A 18x26x1,5</p>	<p>K:← 069.590 71 741 016 AW/BS RD FPM 31x41x7 K:→ 199.191 71 718 365 SP LD FPM 93x12 N:← 434.500 46 802 577 A/BS RD FPM 30x45x7</p>	<p>TLS 434.420 </p>



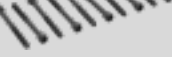









<p>ALFA ROMEO</p> 				
<p>937 A6.000</p> <p>4 Cyl. 1910 ccm Cyl. 82,0 Ø</p> <p>Alfa 147 JTDM 06/2008 → 03/2010</p> <p>GT JTD 05/2008 → 09/2010</p>	<p>ES⊕ 491.980 71 730 214 →Mot. 5192515</p>  <p>ES⊕ 585.020 71 753 439 Mot. 5192516→</p>  <p>CS 387.580 71 730 404</p>	<p>217.052 55 200 890</p>  <p>→ 0,100 mm</p> <p>0,82 mm ± 83 Ø</p> <p>008.822 55 201 694</p>  <p>→ 0,101 mm</p> <p>→ 0,200 mm</p> <p>0,92 mm ± 83 Ø 1 ⊗</p> <p>008.832 55 201 695</p>  <p>→ 0,201 mm</p> <p>→ 0,295 mm</p> <p>1,02 mm ± 83 Ø 2 ⊗</p>	<p>ZKS 642.100 55 571 777 (10x) M 12x1,25x224,5</p>  <p>ZKS 687.330 55 214 216 (10x) M 12x1,25x219</p>	<p>875.350 46 814 174</p> 
<p>937 A7.000</p> <p>4 Cyl. 1910 ccm Cyl. 82,0 Ø</p> <p>Alfa 159 JTDM 09/2005 → 11/2011</p>	<p>ES⊕ 498.980 71 739 971</p>  <p>OKS 724.580 71 749 333 71 737 925</p>  <p>OKS 926.020 71 749 333</p>	<p>217.001 55 200 891</p>  <p>→ 0,020 mm</p> <p>→ 0,100 mm</p> <p>0,82 mm ± 83 Ø</p> <p>217.021 55 202 010</p>  <p>→ 0,101 mm</p> <p>→ 0,200 mm</p> <p>0,92 mm ± 83 Ø 1 ⊗</p> <p>217.031 55 202 011</p>  <p>→ 0,201 mm</p> <p>→ 0,295 mm</p> <p>1,02 mm ± 83 Ø 2 ⊗</p>	<p>ZKS 152.440 7775920 (10x) M 12x1,25x218 →Mot. 5688563 (159)</p>  <p>ZKS 642.100 55 571 777 (10x) M 12x1,25x224,5 Mot. 5688564 (159)→</p>  <p>ZKS 687.330 55 214 216 (10x) M 12x1,25x219 Mot. 5688564 (159)→</p>	<p>430.400 55 197 598</p> 
<p>939 A1.000 939 A7.000</p> <p>4 Cyl. 1910 ccm Cyl. 82,0 Ø</p> <p>Alfa 147 JTDM 10/2004 → 03/2010</p> <p>Alfa 159 JTDM 09/2005 → 11/2011</p>	<p>ES⊕ 498.980 71 739 971</p>  <p>OKS 724.580 71 749 333 71 737 925</p>  <p>OKS 926.020 71 749 333</p>	<p>217.001 55 200 891</p>  <p>→ 0,020 mm</p> <p>→ 0,100 mm</p> <p>0,82 mm ± 83 Ø</p> <p>217.021 55 202 010</p>  <p>→ 0,101 mm</p> <p>→ 0,200 mm</p> <p>0,92 mm ± 83 Ø 1 ⊗</p> <p>217.031 55 202 011</p>  <p>→ 0,201 mm</p> <p>→ 0,295 mm</p> <p>1,02 mm ± 83 Ø 2 ⊗</p>	<p>ZKS 152.440 7775920 (10x) M 12x1,25x218 →Mot. 5689936 (147) →Mot. 5688563 (159)</p>  <p>ZKS 687.330 55 214 216 (10x) M 12x1,25x219 Mot. 5688564 (159)→ Mot. 5689937 (147)→</p>  <p>ZKS 642.100 55 571 777 (10x) M 12x1,25x224,5 Mot. 5689937 (147)→ Mot. 5688564 (159)→</p> 	<p>430.400 55 197 598</p> 











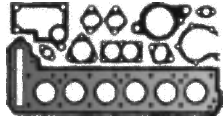
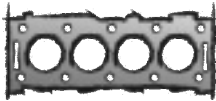

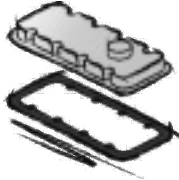

			<p>a) </p> <p>b) </p>	<p>K: </p> <p>N: </p>	
<p>VAS 332.470 FPM →Mot. 5192515</p> <p>332.330 46 743 167 FPM →Mot. 5192515 16x</p> <p>506.550 55 183 812 FPM Mot. 5192516→ 16x</p>	<p>448.510 73 502 761</p> 	<p>439.000 46 816 020</p> 	<p>a) 030.793 Dirko HT</p> <p>b) 877.920 incl. 339.580 60 813 578 M 18x1,5x22</p> <p>b) 339.580 55 196 309 CU A 18x26x1,5</p>	<p>K:← 069.590 71 741 016 AW/BS RD FPM 31x41x7</p> <p>K:→ 199.191 71 718 365 SP LD FPM 93x12</p> <p>N:← 434.500 46 802 577 A/BS RD FPM 30x45x7</p>	
<p>VAS 294.250 FPM</p> <p>294.110 60 513 469 FPM 8x</p>	<p>458.360 46 467 747</p> 	<p>879.280 60 816 179</p> 	<p>a) 030.793 Dirko HT</p> <p>b) 877.920 incl. 339.580 60 813 578 M 18x1,5x22</p> <p>b) 878.030 incl. 359.300 55 196 505 M 18x1,5x20</p> <p>b) 339.580 55 196 309 CU A 18x26x1,5</p> <p>b) 359.300 FPM A 18x26x1,5 FE/FPM</p>	<p>K:← 069.590 71 741 016 AW/BS RD FPM 31x41x7</p> <p>K:→ 199.191 71 718 365 SP LD FPM 93x12</p> <p>N:← 505.838 71 753 052 ASW RD FPM 30x42x7</p>	<p>TLS 703.930</p> 
<p>VAS 294.250 FPM</p> <p>294.110 60 513 469 FPM 8x</p>	<p>458.360 46 467 747</p> 	<p>879.280 60 816 179</p> 	<p>a) 030.793 Dirko HT</p> <p>b) 877.920 incl. 339.580 60 813 578 M 18x1,5x22</p> <p>b) 878.030 incl. 359.300 55 196 505 M 18x1,5x20</p> <p>b) 339.580 55 196 309 CU A 18x26x1,5</p> <p>b) 359.300 FPM A 18x26x1,5 FE/FPM</p>	<p>K:← 069.590 71 741 016 AW/BS RD FPM 31x41x7</p> <p>K:→ 199.191 71 718 365 SP LD FPM 93x12</p> <p>N:← 505.838 71 753 052 ASW RD FPM 30x42x7</p>	<p>TLS 703.930</p> 

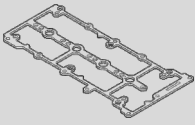



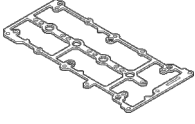



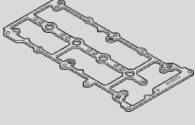





<p>ALFA ROMEO</p> 				
<p>937 A8.000 939 A2.000 939 A8.000</p> <p>4 Cyl. 1910 ccm Cyl. 82,0 Ø</p> <p>Alfa 159 JTDM 09/2005 → 11/2011</p>	<p>ES⊕ 491.980 71 730 214 →Mot. 5192515</p>  <p>ES⊕ 585.020 71 753 439 Mot. 5192516→</p>  <p>OKS 724.580 71 749 333 71 737 925</p>  <p>OKS 926.020 71 749 333</p>	<p>217.052 55 200 890</p>  <p>→ 0,100 mm</p> <p>0,82 mm $\frac{\pm}{\pm}$ 83 Ø</p> <p>008.822 55 201 694</p>  <p>→ 0,101 mm</p> <p>→ 0,200 mm</p> <p>0,92 mm $\frac{\pm}{\pm}$ 83 Ø 1 ⊗</p> <p>008.832 55 201 695</p>  <p>→ 0,201 mm</p> <p>→ 0,295 mm</p> <p>1,02 mm $\frac{\pm}{\pm}$ 83 Ø 2 ⊗</p>	<p>ZKS 642.100 55 571 777 (10x) M 12x1,25x224,5</p>  <p>ZKS 687.330 55 214 216 (10x) M 12x1,25x219</p>	<p>875.350 46 814 174</p> 
<p>AR 32302</p> <p>4 Cyl. 1910 ccm Cyl. 82,0 Ø</p> <p>Alfa 145 JTD 02/1999 → 01/2001</p> <p>Alfa 146 JTD 02/1999 → 01/2001</p> <p>Alfa 156 JTD 09/1997 → 10/2000</p>	<p>S⊕* 074.660 71 712 830</p>  <p>ES⊕ 074.670 71 712 831</p> 	<p>186.532 ● 46 447 765</p>  <p>→ 0,750 mm</p> <p>→ 0,880 mm</p> <p>1,60 mm $\frac{\pm}{\pm}$ 83 Ø</p> <p>186.542 ● 46 449 944</p>  <p>→ 0,890 mm</p> <p>→ 0,970 mm</p> <p>1,70 mm $\frac{\pm}{\pm}$ 83 Ø 1 ⊗</p> <p>186.552 ● 46 449 945</p>  <p>→ 0,980 mm</p> <p>→ 1,062 mm</p> <p>1,80 mm $\frac{\pm}{\pm}$ 83 Ø 2 ⊗</p>	<p>ZKS 152.440 7775920 (10x) M 12x1,25x218</p> 	<p>199.160 46 432 087</p> 
<p>AR 37101</p> <p>4 Cyl. 1910 ccm Cyl. 82,0 Ø</p> <p>Alfa 156 JTD 10/2000 → 05/2001</p>	<p>S⊕* 180.000 60 816 452 →Mot. 4081110</p>  <p>ES⊕ 180.060 60 816 453 →Mot. 4081110</p>  <p>ES⊕ 498.980 71 739 971 Mot. 4081111→</p>  <p>CS 387.580 71 730 404</p>	<p>217.001 55 200 891</p>  <p>→ 0,020 mm</p> <p>→ 0,100 mm</p> <p>0,82 mm $\frac{\pm}{\pm}$ 83 Ø</p> <p>217.021 55 202 010</p>  <p>→ 0,101 mm</p> <p>→ 0,200 mm</p> <p>0,92 mm $\frac{\pm}{\pm}$ 83 Ø 1 ⊗</p> <p>217.031 55 202 011</p>  <p>→ 0,201 mm</p> <p>→ 0,295 mm</p> <p>1,02 mm $\frac{\pm}{\pm}$ 83 Ø 2 ⊗</p>	<p>ZKS 152.440 7775920 (10x) M 12x1,25x218</p> 	<p>199.030 46 552 748 →Mot. 4081110</p>  <p>430.400 55 197 598 Mot. 4081111→</p> 











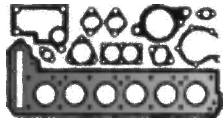
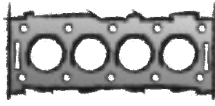

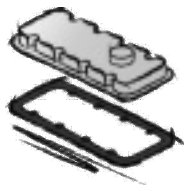
			<p>a) </p> <p>b) </p>	<p>K: </p> <p>N: </p>	
<p>VAS 332.470 FPM →Mot. 5192515</p> <p>332.330 46 743 167 FPM →Mot. 5192515 16x</p> <p>506.550 55 183 812 FPM Mot. 5192516→ 16x</p>	<p>448.510 73 502 761</p> 	<p>439.000 46 816 020</p> 	<p>a) 030.793 Dirko HT</p> <p>b) 877.920 incl. 339.580 60 813 578 M 18x1,5x22</p> <p>b) 878.030 incl. 359.300 55 196 505 M 18x1,5x20</p> <p>b) 339.580 55 196 309 CU A 18x26x1,5</p> <p>b) 359.300 FPM A 18x26x1,5 FE/FPM</p>	<p>K:← 069.590 71 741 016 AW/BS RD FPM 31x41x7</p> <p>K:→ 199.191 71 718 365 SP LD FPM 93x12</p> <p>N:← 434.500 46 802 577 A/BS RD FPM 30x45x7</p>	<p>TLS 703.940</p> 
<p>VAS 294.250 FPM</p> <p>294.110 60 513 469 FPM 8x</p>	<p>458.360 46 467 747</p> 	<p>290.790 46 437 440 →Mot. 1815272</p>  <p>879.280 60 816 179 Mot. 1815273→</p> 	<p>a) 030.793 Dirko HT</p> <p>b) 877.920 incl. 339.580 60 813 578 M 18x1,5x22</p> <p>b) 339.580 55 196 309 CU A 18x26x1,5</p>	<p>K:← 069.590 71 741 016 AW/BS RD FPM 31x41x7</p> <p>K:→ 199.191 71 718 365 SP LD FPM 93x12</p> <p>N:← 505.838 71 753 052 ASW RD FPM 30x42x7</p>	
<p>VAS 294.250 FPM</p> <p>294.110 60 513 469 FPM 8x</p>	<p>458.360 46 467 747</p> 	<p>879.280 60 816 179</p> 	<p>a) 030.793 Dirko HT</p> <p>b) 877.920 incl. 339.580 60 813 578 M 18x1,5x22</p> <p>b) 339.580 55 196 309 CU A 18x26x1,5</p>	<p>K:← 069.590 71 741 016 AW/BS RD FPM 31x41x7</p> <p>K:→ 199.191 71 718 365 SP LD FPM 93x12</p> <p>N:← 505.838 71 753 052 ASW RD FPM 30x42x7</p>	<p>TLS 434.420</p> 



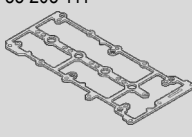

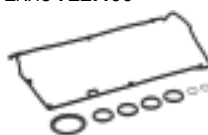

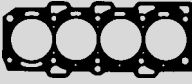

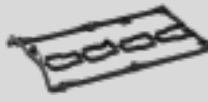



<p>ALFA ROMEO</p> 				
<p>AR 33601/67501</p> <p>4 Cyl. 1929 ccm Cyl. 82,6 Ø</p> <p>Alfa 145 JTD 07/1994 → 02/1999</p> <p>Alfa 145 TD 10/1994 → 02/1999</p> <p>Alfa 146 JTD 05/1995 → 09/1996</p> <p>Alfa 146 TD 12/1994 → 02/1999</p> <p>Alfa 155 TD 04/1993 → 12/1997</p>		<p>724.760 46 431 639 1,65 mm $\frac{\pm}{\pm}$ 83,5 Ø </p> <p>724.770 46 431 640 1,75 mm $\frac{\pm}{\pm}$ 83,5 Ø </p> <p>724.780 46 431 641 1,85 mm $\frac{\pm}{\pm}$ 83,5 Ø </p> <p>724.790 46 431 642 1,95 mm $\frac{\pm}{\pm}$ 83,5 Ø </p> <p>986.373 60 814 219 1,65 mm $\frac{\pm}{\pm}$ 83 Ø </p> <p>986.381 60 814 220 1,75 mm $\frac{\pm}{\pm}$ 83 Ø </p> <p>773.990 60 814 221 1,85 mm $\frac{\pm}{\pm}$ 83 Ø </p> <p>986.390 60 814 222 1,95 mm $\frac{\pm}{\pm}$ 83 Ø </p>	<p>ZKS 760.510 7653650 (10x) M 12x1,25x134</p> 	<p>480.980 60 808 659</p> 
<p>552 83 099</p> <p>4 Cyl. 1956 ccm Cyl. 83,0 Ø</p> <p>Giulietta JTDM 04/2010 → 12/2020</p>	<p>ES⊕ 940.460</p>  <p>CS 926.720</p>	<p>758.710 55 259 469</p> <p> 0,110 mm → 0,230 mm 0,95 mm $\frac{\pm}{\pm}$ 84 Ø</p> <p>758.680 55 259 470</p> <p> 0,231 mm → 0,330 mm 1,05 mm $\frac{\pm}{\pm}$ 84 Ø 1 ⊗</p> <p>758.690 55 259 471</p> <p> 0,331 mm → 0,425 mm 1,15 mm $\frac{\pm}{\pm}$ 84 Ø 2 ⊗</p>	<p>ZKS 687.330 55 214 216 (10x) M 12x1,25x219</p>	<p>748.591 55 205 111</p> 











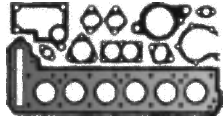
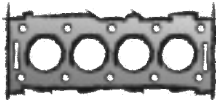

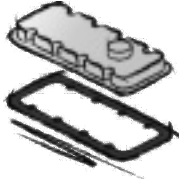

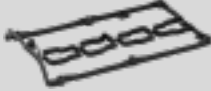

			<p>a) </p> <p>b) </p>	<p>K: </p> <p>N: </p>	
<p>VAS 294.250 FPM</p> <p>294.110 60 513 469 FPM 8x</p>	<p>⇒</p>	<p>480.990 60 809 357</p> 	<p>a) 480.960 60 808 629</p>  <p>b) 587.100 7734022 M 22x1,5x13</p> <p>b) 111.104 2340.32.234 CU A 12x18x1,5</p>	<p>K:← 440.730 60 805 219 AW/BS RD ACM 30x43x8</p> <p>K:→ 440.830 60 805 182 AW/BS LD FPM 74x90x10</p> <p>N:← 440.750 60 801 282 AW/BS RD FPM 30x52x7</p>	
<p>506.550 55 183 812 FPM 16x</p>	<p>748.530 55 222 403 Euro 5</p>  <p>907.400 Euro 6</p> 	<p>AAS 340.470 71 754 211</p> 	<p>a) 030.793 Dirko HT</p> <p>b) 877.920 incl. 339.580 60 813 578 M 18x1,5x22</p> <p>b) 878.030 incl. 359.300 55 196 505 M 18x1,5x20</p> <p>b) 339.580 55 196 309 CU A 18x26x1,5</p> <p>b) 359.300 FPM A 18x26x1,5 FE/FPM</p>	<p>K:← 069.590 71 741 016 AW/BS RD FPM 31x41x7</p> <p>K:→ 199.191 71 718 365 SP LD FPM 93x12</p> <p>N:← 434.500 46 802 577 A/BS RD FPM 30x45x7</p>	





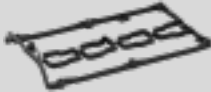









<p>ALFA ROMEO</p> 				
<p>844 A2.000 939 B3.000 939 B4.000</p> <p>4 Cyl. 1956 ccm Cyl. 83,0 Ø</p> <p>Alfa 159 JTDM 05/2009 → 11/2011</p> <p>Brera JTDM 03/2008 → 06/2010</p> <p>Spider JTDM 04/2009 → 03/2011</p>	<p>ES⊕ 940.460</p>  <p>CS* 592.910 71749743 71 749 743 +71718365</p> <p>CS 926.720</p>	<p>758.710 55 259 469</p>  <p>0,110 mm → 0,230 mm</p> <p>0,95 mm $\frac{1}{2}$ 84 Ø</p> <p>758.680 55 259 470</p>  <p>0,231 mm → 0,330 mm</p> <p>1,05 mm $\frac{1}{2}$ 84 Ø 1 ⊗</p> <p>758.690 55 259 471</p>  <p>0,331 mm → 0,425 mm</p> <p>1,15 mm $\frac{1}{2}$ 84 Ø 2 ⊗</p>	<p>ZKS 687.330 55 214 216 (10x) M 12x1,25x219</p>	<p>748.591 55 205 111</p> 
<p>939 B5.000 940 A4.000 940 A7.000 940 B4.000 940 B5.000 940 B9.000</p> <p>4 Cyl. 1956 ccm Cyl. 83,0 Ø</p> <p>Giulietta JTDM 04/2010 → 12/2020</p>	<p>ES⊕ 940.460</p>  <p>CS 926.720</p>	<p>758.710 55 259 469</p>  <p>0,110 mm → 0,230 mm</p> <p>0,95 mm $\frac{1}{2}$ 84 Ø</p> <p>758.680 55 259 470</p>  <p>0,231 mm → 0,330 mm</p> <p>1,05 mm $\frac{1}{2}$ 84 Ø 1 ⊗</p> <p>758.690 55 259 471</p>  <p>0,331 mm → 0,425 mm</p> <p>1,15 mm $\frac{1}{2}$ 84 Ø 2 ⊗</p>	<p>ZKS 687.330 55 214 216 (10x) M 12x1,25x219</p>	<p>748.591 55 205 111</p> 
<p>940 A5.000 940 A8.000 940 B6.000</p> <p>4 Cyl. 1956 ccm Cyl. 83,0 Ø</p> <p>Giulietta JTDM 04/2010 → 12/2020</p>	<p>ES⊕ 693.880 71 769 839</p>  <p>CS 926.720</p>	<p>758.710 55 259 469</p>  <p>0,110 mm → 0,230 mm</p> <p>0,95 mm $\frac{1}{2}$ 84 Ø</p> <p>758.680 55 259 470</p>  <p>0,231 mm → 0,330 mm</p> <p>1,05 mm $\frac{1}{2}$ 84 Ø 1 ⊗</p> <p>758.690 55 259 471</p>  <p>0,331 mm → 0,425 mm</p> <p>1,15 mm $\frac{1}{2}$ 84 Ø 2 ⊗</p>	<p>ZKS 687.330 55 214 216 (10x) M 12x1,25x219</p>	<p>748.591 55 205 111</p> 



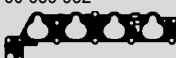







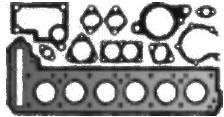
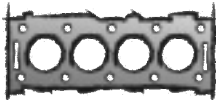

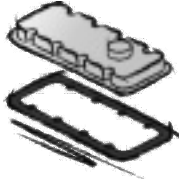
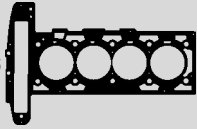





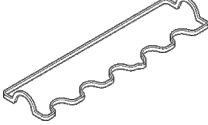





			<p>a) </p> <p>b) </p>	<p>K: </p> <p>N: </p>	
<p>506.550 55 183 812 FPM 16x</p>	<p>748.530 55 222 403 Euro 5</p> 	<p>AAS 340.470 71 754 211</p> 	<p>a) 030.793 Dirko HT</p> <p>b) 877.920 incl. 339.580 60 813 578 M 18x1,5x22</p> <p>b) 878.030 incl. 359.300 55 196 505 M 18x1,5x20</p> <p>b) 339.580 55 196 309 CU A 18x26x1,5</p> <p>b) 359.300 FPM A 18x26x1,5 FE/FPM</p>	<p>K:← 069.590 71 741 016 AW/BS RD FPM 31x41x7</p> <p>K:→ 199.191 71 718 365 SP LD FPM 93x12</p> <p>N:← 434.500 46 802 577 A/BS RD FPM 30x45x7</p>	
<p>506.550 55 183 812 FPM 16x</p>	<p>748.530 55 222 403 Euro 5</p> 	<p>AAS 340.470 71 754 211</p> 	<p>a) 030.793 Dirko HT</p> <p>b) 877.920 incl. 339.580 60 813 578 M 18x1,5x22</p> <p>b) 878.030 incl. 359.300 55 196 505 M 18x1,5x20</p> <p>b) 339.580 55 196 309 CU A 18x26x1,5</p> <p>b) 359.300 FPM A 18x26x1,5 FE/FPM</p>	<p>K:← 069.590 71 741 016 AW/BS RD FPM 31x41x7</p> <p>K:→ 199.191 71 718 365 SP LD FPM 93x12</p> <p>N:← 434.500 46 802 577 A/BS RD FPM 30x45x7</p>	
<p>506.550 55 183 812 FPM 16x</p>	<p>748.510 55 210 879</p> 	<p>AAS 340.470 71 754 211</p> 	<p>a) 030.793 Dirko HT</p> <p>b) 877.920 incl. 339.580 60 813 578 M 18x1,5x22</p> <p>b) 878.030 incl. 359.300 55 196 505 M 18x1,5x20</p> <p>b) 339.580 55 196 309 CU A 18x26x1,5</p> <p>b) 359.300 FPM A 18x26x1,5 FE/FPM</p>	<p>K:← 069.590 71 741 016 AW/BS RD FPM 31x41x7</p> <p>K:→ 199.191 71 718 365 SP LD FPM 93x12</p> <p>N:← 434.500 46 802 577 A/BS RD FPM 30x45x7</p>	

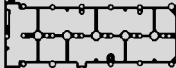







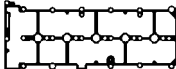





<p>ALFA ROMEO</p> 				
<p>940 C3.000 940 C4.000</p> <p>4 Cyl. 1956 ccm Cyl. 83,0 Ø</p> <p>Giulietta JTDM 04/2010 → 10/2018</p>	<p>CS 926.720</p>	<p>758.710 55 259 469  0,110 mm → 0,230 mm 0,95 mm $\frac{\pm}{\pm}$ 84 Ø</p> <p>758.680 55 259 470  0,231 mm → 0,330 mm 1,05 mm $\frac{\pm}{\pm}$ 84 Ø 1 ⊗</p> <p>758.690 55 259 471  0,331 mm → 0,425 mm 1,15 mm $\frac{\pm}{\pm}$ 84 Ø 2 ⊗</p>	<p>ZKS 687.330 55 214 216 (10x) M 12x1,25x219</p>	<p>748.591 55 205 111</p> 
<p>932 A2.000 937 A1.000</p> <p>4 Cyl. 1970 ccm Cyl. 83,0 Ø</p> <p>Alfa 147 07/2002 → 05/2005</p> <p>Alfa 156 03/2001 → 05/2006</p> <p>GT 11/2003 → 09/2010</p> <p>GTV 04/2003 → 10/2005</p> <p>Spider 04/2003 → 04/2005</p>	<p>ES⊕ 472.180 71 737 152</p> <p>CS* 431.250 71 719 779</p>	<p>862.553 55 187 704 0,49 mm $\frac{\pm}{\pm}$</p> 	<p>ZKS 152.080 7710582 (10x) M 10x1,25x254</p> 	<p>ZKHS 722.400</p>  <p>375.060 55 187 339</p> 
<p>AR 32301</p> <p>4 Cyl. 1970 ccm Cyl. 83,0 Ø</p> <p>Alfa 145 03/1998 → 01/2001</p> <p>Alfa 146 03/1997 → 10/2001</p> <p>Alfa 156 09/1997 → 06/2002</p> <p>GTV 09/1997 → 03/2003</p> <p>Spider 05/1998 → 08/2000</p>	<p>S⊕* 180.970 71 713 634</p> <p>ES⊕ 180.980 71 713 635</p> <p>CS* 431.250 71 719 779</p>	<p>180.770 60 608 895 1,65 mm $\frac{\pm}{\pm}$ 83,9 Ø</p> 	<p>ZKS 152.080 7710582 (10x) M 10x1,25x254</p> 	<p>199.080 60 655 592</p> 







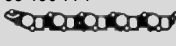

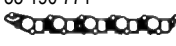

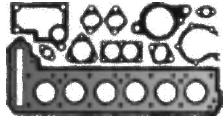
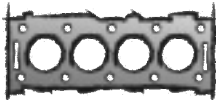

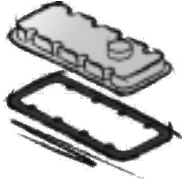







			<p>a) </p> <p>b) </p>	<p>K: </p> <p>N: </p>	
<p>506.550 55 183 812 FPM 16x</p>		<p>AAS 340.470 71 754 211</p> 	<p>a) 030.793 Dirko HT</p> <p>b) 877.920 incl. 339.580 60 813 578 M 18x1,5x22</p> <p>b) 878.030 incl. 359.300 55 196 505 M 18x1,5x20</p> <p>b) 339.580 55 196 309 CU A 18x26x1,5</p> <p>b) 359.300 FPM A 18x26x1,5 FE/FPM</p>	<p>K:← 069.590 71 741 016 AW/BS RD FPM 31x41x7</p> <p>K:→ 199.191 71 718 365 SP LD FPM 93x12</p> <p>N:← 434.500 46 802 577 A/BS RD FPM 30x45x7</p>	
<p>VAS 825.042 FPM 2x</p> <p>701.289 46 440 885 FPM 16x</p>	<p>448.510 73 502 761</p> 	<p>875.490 60 673 137</p> 	<p>a) 030.793 Dirko HT</p> <p>a) 365.020 60 626 642</p> <p>b) 877.920 incl. 339.580 60 813 578 M 18x1,5x22</p> <p>b) 339.580 55 196 309 CU A 18x26x1,5</p>	<p>K:← 069.590 71 741 016 AW/BS RD FPM 31x41x7</p> <p>K:→ 199.191 71 718 365 SP LD FPM 93x12</p> <p>N:← 477.010 60 603 436 AW/BS RD FPM 55x68x8</p> <p>N:← 505.838 71 753 052 ASW RD FPM 30x42x7</p>	
<p>VAS 825.042 FPM 2x</p> <p>701.289 46 440 885 FPM 16x</p>	<p>448.510 73 502 761</p> 	<p>685.150 60 659 952</p> 	<p>a) 030.793 Dirko HT</p> <p>a) 365.020 60 626 642</p> <p>b) 877.920 incl. 339.580 60 813 578 M 18x1,5x22</p> <p>b) 339.580 55 196 309 CU A 18x26x1,5</p>	<p>K:← 069.590 71 741 016 AW/BS RD FPM 31x41x7</p> <p>K:→ 199.191 71 718 365 SP LD FPM 93x12</p> <p>K:→ 440.830 60 805 182 AW/BS LD FPM 74x90x10</p> <p>N:← 477.010 60 603 436 AW/BS RD FPM 55x68x8</p> <p>N:← 505.838 71 753 052 ASW RD FPM 30x42x7</p>	



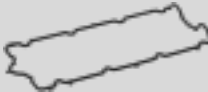











ALFA ROMEO 				
AR 32303/34103 4 Cyl. 1970 ccm Cyl. 83,0 Ø Alfa 166 09/1998 → 10/2000	S⊕* 180.970 71 713 634 →Mot. 2832057 ES⊕ 180.980 71 713 635 CS* 431.250 71 719 779	180.770 60 608 895 1,65 mm $\frac{\pm}{\pm}$ 83,9 Ø 	ZKS 152.080 7710582 (10x) M 10x1,25x254 	199.080 60 655 592 
AR 32310 4 Cyl. 1970 ccm Cyl. 83,0 Ø Alfa 147 01/2001 → 03/2010 Alfa 156 09/1997 → 06/2002 GTV 06/1995 → 10/2005 Spider 06/1995 → 04/2005	S⊕* 180.570 71 717 686 →Mot. 2832057 ES⊕ 180.600 71 717 685 →Mot. 2832057 CS* 431.250 71 719 779	626.727 60 664 642 0,49 mm $\frac{\pm}{\pm}$ 84 Ø  →Mot. 2832057 006.702 60 677 983 0,50 mm $\frac{\pm}{\pm}$ 84 Ø  Mot. 2832058→	ZKS 152.080 7710582 (10x) M 10x1,25x254 	199.080 60 655 592 
AR 36301 4 Cyl. 1970 ccm Cyl. 83,0 Ø Alfa 166 10/2000 → 06/2007	S⊕* 180.570 71 717 686 →Mot. 2557364 ES⊕ 180.600 71 717 685 →Mot. 2557364 CS* 431.250 71 719 779	626.727 60 664 642 0,49 mm $\frac{\pm}{\pm}$ 84 Ø  →Mot. 2557364 006.702 60 677 983 0,50 mm $\frac{\pm}{\pm}$ 84 Ø  Mot. 2557365→	ZKS 152.080 7710582 (10x) M 10x1,25x254 	199.080 60 655 592 
AR 16201/67204/67299 4 Cyl. 1970 ccm Cyl. 83,0 Ø Alfa 145 10/1995 → 01/2001 Alfa 146 10/1995 → 01/2001 Alfa 155 03/1995 → 12/1997 GTV 06/1995 → 10/2005 Spider 06/1995 → 04/2005	S⊕* 180.900 71 711 280 01/1997→ ES⊕ 180.890 5895155 →12/1996 ES⊕ 180.910 71 711 279 01/1997→	180.770 60 608 895 1,65 mm $\frac{\pm}{\pm}$ 83,9 Ø 	ZKS 152.080 7710582 (10x) M 10x1,25x254 	ZKHS 199.020 60 607 218 +60 607 219 
EC2 4 Cyl. 1995 ccm Cyl. 84,0 Ø Giulia 08/2016 → Stelvio 12/2016 →				



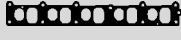







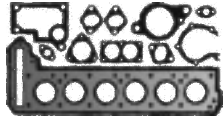
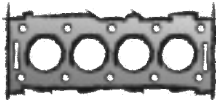

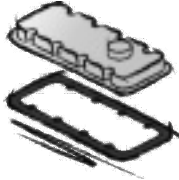
			<p>a) </p> <p>b) </p>	<p>K: </p> <p>N: </p>	
<p>VAS 825.042 FPM 2x 701.289 46 440 885 FPM 16x</p>	<p>448.510 73 502 761 </p>	<p>685.150 60 659 952 </p>	<p>a) 030.793 Dirko HT b) 877.920 incl. 339.580 60 813 578 M 18x1,5x22 b) 339.580 55 196 309 CU A 18x26x1,5</p>	<p>K:← 069.590 71 741 016 AW/BS RD FPM 31x41x7 K:→ 199.191 71 718 365 SP LD FPM 93x12 K:→ 440.830 60 805 182 AW/BS LD FPM 74x90x10 N:← 477.010 60 603 436 AW/BS RD FPM 55x68x8 N:← 505.838 71 753 052 ASW RD FPM 30x42x7</p>	
<p>VAS 825.042 FPM 2x 701.289 46 440 885 FPM 16x</p>	<p>448.510 73 502 761 </p>	<p>685.150 60 659 952 </p>	<p>a) 030.793 Dirko HT a) 365.020 60 626 642 b) 877.920 incl. 339.580 60 813 578 M 18x1,5x22 b) 339.580 55 196 309 CU A 18x26x1,5</p>	<p>K:← 069.590 71 741 016 AW/BS RD FPM 31x41x7 K:→ 199.191 71 718 365 SP LD FPM 93x12 N:← 477.010 60 603 436 AW/BS RD FPM 55x68x8 N:← 505.838 71 753 052 ASW RD FPM 30x42x7</p>	
<p>VAS 825.042 FPM 2x 701.289 46 440 885 FPM 16x</p>	<p>448.510 73 502 761 </p>	<p>685.150 60 659 952 </p>	<p>a) 030.793 Dirko HT b) 877.920 incl. 339.580 60 813 578 M 18x1,5x22 b) 339.580 55 196 309 CU A 18x26x1,5</p>	<p>K:← 069.590 71 741 016 AW/BS RD FPM 31x41x7 K:→ 199.191 71 718 365 SP LD FPM 93x12 N:← 477.010 60 603 436 AW/BS RD FPM 55x68x8 N:← 505.838 71 753 052 ASW RD FPM 30x42x7</p>	
<p>VAS 825.042 FPM 2x 701.289 46 440 885 FPM 16x</p>	<p>448.510 73 502 761 </p>	<p>685.150 60 659 952 </p>	<p>a) 030.793 Dirko HT a) 365.020 60 626 642 b) 877.920 incl. 339.580 60 813 578 M 18x1,5x22 b) 339.580 55 196 309 CU A 18x26x1,5</p>	<p>K:← 069.590 71 741 016 AW/BS RD FPM 31x41x7 K:→ 199.191 71 718 365 SP LD FPM 93x12 N:← 477.010 60 603 436 AW/BS RD FPM 55x68x8 N:← 505.838 71 753 052 ASW RD FPM 30x42x7</p>	
			<p>a) 030.793 Dirko HT</p>	<p>K:← 127.610 71 739 386 ASW RD FPM/ACM 42x55x7</p>	











ALFA ROMEO  Das Original				
939 A5.000 4 Cyl. 2198 ccm Cyl. 86,0 Ø Alfa 159 09/2005 → 11/2011 Brera 01/2006 → 05/2011 Spider 03/2006 → 03/2011	ES⊕ 926.710 CS* 382.130	151.611 55 192 574 0,64 mm $\frac{\pm}{\pm}$ 87 Ø 	ZKS 257.910 71 739 374 (10x) M 11x1,5x162  ZKS 509.710 71 739 374 (10x) M 11x1,5x162 / M 8 	ZKHS 926.700 55 189 690
839 A6.000 841 C000 AR 36202 5 Cyl. 2387 ccm Cyl. 82,0 Ø Alfa 156 JTD 10/2000 → 05/2006 Alfa 166 JTD 10/2000 → 06/2007	ES⊕ 180.100 60 816 595 	626.761 ● 60 816 562 0,82 mm $\frac{\pm}{\pm}$ 83 Ø 	ZKS 152.760 7775920 (12x) M 12x1,25x218 	199.040 46 739 261 
841 G.000 841 H.000 841 M.000 841 N.000 936 B.000 M 722 BT 24.T 5 Cyl. 2387 ccm Cyl. 82,0 Ø Alfa 156 JTD 06/2003 → 05/2006 Alfa 166 JTD 10/2003 → 06/2007		036.355 55 190 353  0,020 mm → 0,100 mm 0,82 mm $\frac{\pm}{\pm}$ 83 Ø 036.365 55 190 354  0,101 mm → 0,200 mm 0,92 mm $\frac{\pm}{\pm}$ 83 Ø 1 ⊗ 036.375 55 190 355  0,201 mm → 0,295 mm 1,02 mm $\frac{\pm}{\pm}$ 83 Ø 2 ⊗   	ZKS 497.410 46 764 762 (12x) M 12x1,25x224 →08/2007 	375.340 46 814 175 
939 A3.000 939 A9.000 5 Cyl. 2387 ccm Cyl. 82,0 Ø Alfa 159 JTDM 09/2005 → 12/2012 Brera JTDM 01/2006 → 03/2011 Spider JTDM 03/2006 → 03/2011	ES⊕ 356.180 71 740 961 Mot. 5553218→ 	061.151 55 184 740  0,110 mm → 0,230 mm 0,95 mm $\frac{\pm}{\pm}$ 83 Ø 061.161 55 184 741  0,231 mm → 0,330 mm 1,05 mm $\frac{\pm}{\pm}$ 83 Ø 1 ⊗ 061.171 55 184 742  0,331 mm → 0,425 mm 1,15 mm $\frac{\pm}{\pm}$ 83 Ø 2 ⊗   	ZKS 497.410 46 764 762 (12x) M 12x1,25x224 →08/2007 	375.340 46 814 175 

			<p>a) </p> <p>b) </p>	<p>K: </p> <p>N: </p>	
<p>VAS 538.080 FPM</p> <p>007.030 71 739 347 FPM 16x</p> 	<p>151.690 55 193 545</p>	<p>040.331 55 182 628</p> 	<p>a) 030.793 Dirko HT</p> <p>b) 823.400 71 739 255 M 12x1,75x17</p> <p>b) 056.130 71 739 194 FPM RD 10,8x20,8x2,6</p>	<p>K:← 127.610 71 739 386 ASW RD FPM/ACM 42x55x7</p> <p>K:→ 694.770 71 739 336 ASW LD FPM/ACM 90x104x11</p>	
<p>VAS 734.230 FPM</p> <p>294.110 60 513 469 FPM 10x</p>	<p>689.960 46 467 746</p> 	<p>690.140 46 772 390</p> 	<p>a) 030.793 Dirko HT</p> <p>b) 877.920 incl. 339.580 60 813 578 M 18x1,5x22</p> <p>b) 339.580 55 196 309 CU A 18x26x1,5</p>	<p>K:← 069.590 71 741 016 AW/BS RD FPM 31x41x7</p> <p>K:→ 199.191 71 718 365 SP LD FPM 93x12</p> <p>N:← 505.838 71 753 052 ASW RD FPM 30x42x7</p>	
<p>332.330 46 743 167 FPM 20x</p>	<p>725.850 73 502 779</p> 	<p>331.230 55 190 771</p> 	<p>a) 030.793 Dirko HT</p> <p>b) 877.920 incl. 339.580 60 813 578 M 18x1,5x22</p> <p>b) 339.580 55 196 309 CU A 18x26x1,5</p>	<p>K:← 069.590 71 741 016 AW/BS RD FPM 31x41x7</p> <p>K:→ 199.191 71 718 365 SP LD FPM 93x12</p> <p>N:← 434.500 46 802 577 A/BS RD FPM 30x45x7</p>	
<p>332.330 46 743 167 FPM →Mot. 5553217 20x</p> <p>506.550 55 183 812 FPM Mot. 5553218→ 20x</p>	<p>725.850 73 502 779</p> 	<p>331.230 55 190 771</p> 	<p>a) 030.793 Dirko HT</p> <p>b) 877.920 incl. 339.580 60 813 578 M 18x1,5x22</p> <p>b) 339.580 55 196 309 CU A 18x26x1,5</p>	<p>K:← 069.590 71 741 016 AW/BS RD FPM 31x41x7</p> <p>K:→ 199.191 71 718 365 SP LD FPM 93x12</p> <p>N:← 434.500 46 802 577 A/BS RD FPM 30x45x7</p>	

<p>ALFA ROMEO</p> 				
<p>AR 32501/34202</p> <p>5 Cyl. 2387 ccm Cyl. 82,0 Ø</p> <p>Alfa 156 JTD 09/1997 → 09/2003</p> <p>Alfa 166 JTD 09/1998 → 10/2000</p>	<p>S⊕* 180.650 ● 71 712 361</p>  <p>ES⊕ 180.730 71 712 360</p> 	<p>184.921 46 442 435 1,60 mm $\frac{\pm}{\pm}$ 83 Ø</p>  <p>184.951 46 442 436 1,70 mm $\frac{\pm}{\pm}$ 83 Ø</p>  <p>184.931 46 442 437 1,80 mm $\frac{\pm}{\pm}$ 83 Ø</p> 	<p>ZKS 152.760 7775920 (12x) M 12x1,25x218</p> 	<p>199.050 46 437 256</p> 
<p>VM 81 A VM4HT 2.4</p> <p>4 Cyl. 2393 ccm Cyl. 92,0 Ø</p> <p>Alfa 75 TD 01/1989 → 02/1992</p> <p>Alfa 90 TD 10/1984 → 07/1987</p> <p>Alfetta TD 04/1983 → 12/1984</p>	<p>ES 418.130 60 732 777</p> 	<p>521.339 60 605 900 1,48 mm $\frac{\pm}{\pm}$ 4x</p>  <p>521.347 60 605 899 1,59 mm $\frac{\pm}{\pm}$ 2 ▽ 4x</p>  <p>521.355 60 605 898 1,69 mm $\frac{\pm}{\pm}$ 1 ▽ 4x</p> 		<p>200.941 60 583 721</p> 
<p>AR 32401/32402/32405/ 34201/36201</p> <p>6 Cyl. 2492 ccm Cyl. 88,0 Ø</p> <p>Alfa 156 02/1997 → 05/2006</p> <p>Alfa 166 09/1998 → 06/2007</p>				<p>375.270 60 609 979 L</p>  <p>375.080 60 609 978 R</p> 
<p>VM 07 B VM 08 B VM 84 A</p> <p>4 Cyl. 2499 ccm Cyl. 92,0 Ø</p> <p>Alfa 155 TD 04/1993 → 12/1997</p> <p>Alfa 164 TD 06/1987 → 09/1998</p>	<p>ES 418.130 60 732 777</p> 	<p>521.339 60 605 900 1,48 mm $\frac{\pm}{\pm}$ 4x</p>  <p>521.347 60 605 899 1,59 mm $\frac{\pm}{\pm}$ 2 ▽ 4x</p>  <p>521.355 60 605 898 1,69 mm $\frac{\pm}{\pm}$ 1 ▽ 4x</p> 		<p>200.941 60 583 721</p> 

			<p>a) </p> <p>b) </p>	<p>K: </p> <p>N: </p>	
<p>VAS 734.230 FPM 294.110 60 513 469 FPM 10x</p>	<p>689.960 46 467 746 </p>	<p>690.070 7735415 →01/2000 </p> <p>690.140 46 772 390 01/2000→ </p>	<p>a) 030.793 Dirko HT</p> <p>b) 877.920 incl. 339.580 60 813 578 M 18x1,5x22</p> <p>b) 339.580 55 196 309 CU A 18x26x1,5</p>	<p>K:← 069.590 71 741 016 AW/BS RD FPM 31x41x7</p> <p>K:→ 199.191 71 718 365 SP LD FPM 93x12</p> <p>N:← 505.838 71 753 052 ASW RD FPM 30x42x7</p>	
	<p>435.830 60 507 652 4x </p>	<p>435.810 60 583 742 4x </p>	<p>b) 877.910 incl. 128.503 60 507 149 M 22x1,5x10</p> <p>b) 128.503 10 263 450 CU A 22x27x1,5</p>	<p>K:← 501.123 60 507 534 ASW RD ACM 52x68x8</p> <p>K:→ 298.247 46 139 353 ASW LD FPM/ACM 110x130x13</p>	
<p>VAS 825.050 FPM 2x 701.289 46 440 885 FPM 24x</p>			<p>a) 030.793 Dirko HT</p> <p>b) 128.503 10 263 450 CU A 22x27x1,5</p>	<p>N:← 325.155 ASW WD FPM/ACM 32x47x10 4x</p>	
	<p>435.830 60 507 652 4x </p>	<p>435.810 60 583 742 4x </p>	<p>b) 877.910 incl. 128.503 60 507 149 M 22x1,5x10</p> <p>b) 128.503 10 263 450 CU A 22x27x1,5</p>	<p>K:← 501.123 60 507 534 ASW RD ACM 52x68x8</p> <p>K:→ 298.247 46 139 353 ASW LD FPM/ACM 110x130x13</p>	

<p>ALFA ROMEO</p> 				
<p>VM 31 B VM 32 B</p> <p>4 Cyl. 2499 ccm Cyl. 92,0 Ø</p> <p>Alfa 155 TD 04/1993 → 12/1997</p> <p>Alfa 164 TD 09/1992 → 09/1998</p>	<p>ES 181.000 60 778 967</p> 	<p>521.339 60 605 900 1,48 mm \pm 4x</p>  <p>521.347 60 605 899 1,59 mm \pm 2 ∇ 4x</p>  <p>521.355 60 605 898 1,69 mm \pm 1 ∇ 4x</p> 		<p>446.111 60 778 979</p> 
<p>AR 16102/16105/34301/34302/36101</p> <p>6 Cyl. 2959 ccm Cyl. 93,0 Ø</p> <p>Alfa 166 09/1998 → 06/2007</p> <p>GTV 10/1996 → 10/2005</p> <p>Spider 09/1994 → 04/2005</p>				<p>375.270 60 609 979 L</p>  <p>375.080 60 609 978 R</p> 
<p>932 A.000 936 A.000 936 A6.000</p> <p>6 Cyl. 3179 ccm Cyl. 93,0 Ø</p> <p>Alfa 147 02/2003 → 03/2010</p> <p>Alfa 156 03/2002 → 05/2006</p> <p>Alfa 166 10/2003 → 06/2007</p> <p>GT 11/2003 → 09/2010</p> <p>GTV 04/2003 → 10/2005</p> <p>Spider 04/2003 → 04/2005</p>				<p>375.270 60 609 979 L</p>  <p>375.080 60 609 978 R</p> 

			<p>a) </p> <p>b) </p>	<p>K: </p> <p>N: </p>	
	<p>435.830 60 507 652 4x</p> 	<p>435.810 60 583 742 4x</p> 	<p>b) 877.910 incl. 128.503 60 507 149 M 22x1,5x10</p> <p>b) 128.503 10 263 450 CU A 22x27x1,5</p>	<p>K:← 501.123 60 507 534 ASW RD ACM 52x68x8</p> <p>K:→ 298.247 46 139 353 ASW LD FPM/ACM 110x130x13</p>	
<p>VAS 825.050 FPM 2x</p> <p>701.289 46 440 885 FPM 24x</p>			<p>a) 030.793 Dirko HT</p> <p>b) 128.503 10 263 450 CU A 22x27x1,5</p>	<p>N:← 325.155 ASW WD FPM/ACM 32x47x10 4x</p>	
<p>VAS 825.050 FPM 2x</p> <p>701.289 46 440 885 FPM 24x</p>			<p>a) 030.793 Dirko HT</p> <p>b) 128.503 10 263 450 CU A 22x27x1,5</p>	<p>N:← 325.155 ASW WD FPM/ACM 32x47x10 4x</p>	

AUDI



AUDI	ccm	kW	→	→		
100	4	1781	55	08/1982	12/1987	DR RS 120
100	4	1781	66	08/1983	11/1990	4B DS JW NP PH 120
100	4	1781	65	02/1986	07/1990	SH 120
100	5	1921	74	08/1980	08/1984	WH 148
100	4	1984	74	12/1990	07/1994	AAE 178
100	4	1984	85	12/1990	07/1994	AAD ABK 178 180
100	4	1984	103	01/1992	07/1994	ACE 182
100	5	1994	85	01/1988	11/1990	RT 200
100	5	2226	101	08/1984	11/1990	HX KU 202
100	5	2226	85	10/1984	09/1986	KZ 202
100	5	2226	88	08/1985	07/1986	PX 202
100	5	2226	82	09/1985	12/1987	KZ 202
100	5	2226	117	09/1985	12/1988	MC 202
100	5	2226	118	09/1985	12/1988	MC 202
100	5	2226	169	08/1991	07/1994	AAN 200
100	5	2309	100	08/1986	11/1990	NF 204
100	5	2309	97	09/1986	07/1991	NF 204
100	5	2309	98	01/1990	07/1994	AAR NF 204
100	5	2370	60	08/1989	07/1994	3D AAS 206
100	6	2598	110	03/1992	07/1994	ABC 226
100	6	2598	102	07/1993	07/1994	ACZ 230
100	6	2771	128	12/1990	07/1994	AAH 244
100	8	4172	206	10/1992	07/1994	ABH 348
100 S4	8	4172	206	10/1992	07/1994	ABH 348
100 S4 Turbo	5	2226	169	09/1991	07/1994	AAN 200
100 TD	5	1986	74	03/1988	11/1990	NC 198
100 TDI	5	2461	88	01/1990	11/1990	1T 216
100 TDI	5	2461	85	12/1990	07/1994	AAT ABP 216 218
100 Turbo	5	2226	121	08/1986	11/1990	MC 202
200	5	2226	101	08/1984	07/1985	KU 202
200	5	2309	100	11/1986	09/1991	NF 204
200 Turbo	5	2226	121	09/1983	12/1991	MC 202

AUDI	ccm	kW	→	→		
200 Turbo	5	2226	140	02/1988	12/1990	2B 202
200 Turbo	5	2226	147	02/1988	12/1991	1B 202
200 Turbo	5	2226	162	03/1989	12/1990	3B 200
80	4	1297	44	09/1978	07/1986	EP 72
80	4	1588	40	08/1980	07/1989	CR JK 82 84
80	4	1595	55	08/1978	08/1991	DT JU RN 92
80	4	1595	54	02/1986	07/1986	SA 92
80	4	1595	51	08/1987	09/1991	PP 92
80	4	1595	75	08/1990	10/1991	ABB 86
80	4	1595	52	09/1991	12/1994	ABM 86
80	4	1595	74	06/1993	01/1996	ADA 88
80	4	1781	66	01/1983	10/1991	DS JN JV NE PM SF 118 120
80	4	1781	68	08/1983	08/1986	JN 118
80	4	1781	82	08/1984	08/1991	DZ 118
80	4	1781	81	03/1985	08/1986	PV 120
80	4	1781	65	02/1986	07/1990	SF 120
80	4	1781	55	10/1986	01/1990	RU 120
80	4	1847	83	09/1986	08/1990	SD 126
80	4	1896	50	08/1989	08/1991	1Y 128
80	5	1921	85	09/1981	07/1983	WN 148
80	4	1984	82	08/1988	08/1991	3A AAD 176 178
80	4	1984	83	08/1988	10/1990	3A 176
80	4	1984	101	03/1990	07/1992	6A 176
80	4	1984	85	10/1990	01/1996	AAD ABK 178 180
80	4	1984	66	09/1991	01/1996	ABT 182
80	4	1984	103	04/1992	01/1996	ACE 182
80	4	1984	79	11/1993	01/1996	ADW 184
80	5	2226	100	08/1982	07/1984	HY 202
80	5	2226	88	06/1984	12/1986	KX 202
80	5	2226	89	11/1984	03/1987	JT 202
80	5	2226	169	02/1993	07/1995	ABY 200
80	5	2309	98	10/1987	01/1996	NG 204



AUDI	ccm	kW	→	→		
80	5	2309	97	09/1990	10/1991	NG 204
80	6	2598	110	06/1992	01/1996	ABC 226
80	6	2771	128	09/1991	01/1996	AAH 244 AFC 256
80 RS2	5	2226	232	03/1994	05/1995	ADU 200
80 S2	5	2226	169	02/1993	12/1994	ABY 200
80 TD	4	1588	51	08/1981	05/1986	CY 82
80 TD	4	1588	59	09/1986	08/1991	RA 84 SB
80 TD	4	1896	55	09/1991	12/1994	AAZ 130
80 TDI	4	1896	66	09/1991	01/1996	1Z 128
90	4	1781	82	08/1989	08/1991	DZ 118
90	4	1983	80	09/1987	12/1988	3A 176
90	4	1984	83	08/1989	10/1990	3A 176
90	4	1984	101	08/1989	07/1990	6A 176
90	5	1994	85	07/1988	09/1991	PS 200
90	5	1994	118	08/1988	09/1991	NM 198
90	5	2226	100	10/1984	09/1991	HY 202 KV
90	5	2226	85	01/1985	03/1987	KX 202
90	5	2226	88	08/1985	03/1987	JT 202
90	5	2309	98	04/1987	09/1991	NG 204
90	5	2309	100	04/1987	07/1991	NG 204
90	5	2309	125	06/1988	09/1991	7A 202
90	5	2309	123	04/1990	09/1991	7A 202
90 TD	4	1588	51	10/1985	01/1987	CY 82
90 TD	4	1588	59	04/1987	09/1991	RA 84 SB
A1	3	999	70	03/2015		CHZB 68 DKLA 70 DKLD DLAC
A1	3	999	60	01/2016	10/2018	CHZE 68
A1	3	999	85	07/2018		DKJA 68 DKRF
A1	3	999	81	09/2020		DLAA 70
A1	4	1197	63	05/2010	04/2015	CBZA 70
A1	4	1390	90	05/2010	04/2015	CAXA 74 CNVA
A1	4	1390	136	01/2011	04/2015	CAVG 72 CTHG
A1	4	1395	103	04/2012	04/2015	CPTA 76

AUDI	ccm	kW	→	→		
A1	4	1395	92	11/2014	10/2018	CZCA 74 CZDD
A1	4	1395	110	11/2014	10/2018	CZEA 76
A1	4	1495	110	09/2018		DADA 80 DPCA
A1	4	1798	141	02/2015	10/2018	DAJB 126
A1	4	1984	188	03/2012	11/2012	CDLH 186
A1	4	1984	147	09/2018		CZPC 192 DKZC
A1	4	1984	152	04/2021		DNND 196
A1 S1	4	1984	170	03/2014	10/2018	CWZA 194
A1 TDI	3	1422	66	11/2014	10/2018	CUSB 78
A1 TDI	4	1598	77	05/2010	04/2015	CAYC 96
A1 TDI	4	1598	66	03/2011	04/2015	CAYB 94
A1 TDI	4	1598	85	11/2014	10/2018	CXMA 98
A1 TDI	4	1968	105	09/2011	04/2015	CFHD 154
A1 TDI	4	1968	100	05/2012	04/2015	CFHB 154
A2	4	1390	55	02/2000	08/2005	AUA 72 BBY
A2	4	1598	81	05/2002	08/2005	BAD 92
A2 TDI	3	1191	45	03/2001	08/2005	ANY 70
A2 TDI	3	1422	55	02/2000	08/2005	AMF 76 BHC 78
A2 TDI	3	1422	66	11/2003	08/2005	ATL 78
A3	3	999	85	07/2016	10/2020	CHZD 68 DKRF
A3	3	999	81	06/2020		DLAA 70
A3	4	1197	77	03/2010		CBZB 70 CJZA 72
A3	4	1197	81	05/2014		CYVB 72
A3	4	1390	92	09/2007	05/2013	CAXC 74 CMSA
A3	4	1395	90	04/2012	10/2020	CMBA 74 CXSA
A3	4	1395	103	03/2013		CPTA 76
A3	4	1395	92	09/2013		CXSB 74 CZCA
A3	4	1395	81	11/2013	10/2020	CPWA 74
A3	4	1395	110	05/2014		CUKB 74 CWLA 76 CXUA CZEA DGEA
A3	4	1395	150	05/2014	10/2020	CXUA 74

AUDI



AUDI	ccm	kW	→	→		
A3	4	1395	85	02/2016	10/2020	CZCC 74
A3	4	1495	110	05/2017		DADA DPCA 80
A3	4	1498	96	11/2018		DHFA 80
A3	4	1498	110	04/2020		DFYA 80
A3	4	1595	74	09/1996	05/2003	AEH 88 AKL 90 APF
A3	4	1595	75	08/2000	03/2013	AVU 90 BFQ BGU BSE BSF CCSA CMXA
A3	4	1598	85	08/2003	09/2007	BAG 94 BLF BLP
A3	4	1781	92	09/1996	05/2003	AGN 104 APG 106
A3	4	1781	110	12/1996	05/2003	AGU 104 AQA 110 ARX ARZ AUM
A3	4	1781	132	10/1998	05/2003	AJQ 110 APP ARY AUQ
A3	4	1798	118	11/2006	05/2013	BZB 122 CDA
A3	4	1798	132	04/2012		CJSA 124 CJSB
A3	4	1798	125	11/2013	10/2020	CNSB 124
A3	4	1968	104	01/2010	03/2013	CBEA 154
A3	4	1984	110	05/2003	06/2008	AXW 184 BLR BLX BLY BMB BVY BVZ
A3	4	1984	147	09/2004	05/2013	AXX 186 BPY BWA CAWB CBFA CCTA CCZA
A3	4	1984	162	11/2013	10/2020	CHHB 194 CNTC
A3	4	1984	140	05/2016		CZPB 192 DKZA 196 DNNA
A3	4	1984	137	09/2016	10/2020	CZRA 192

AUDI	ccm	kW	→	→		
A3	4	1984	170	07/2018	10/2020	DHHA 192
A3	6	3189	184	07/2003	05/2009	BDB 324 BMJ BUB
A3 RS3	5	2480	250	01/2011	12/2012	CEPA 218
A3 RS3	5	2480	270	03/2015		CZGB 218
A3 RS3	5	2480	294	04/2017		DAZA 218 DNWA DNWC
A3 S3	4	1781	154	03/1999	04/2002	AMK 112 APY AUL
A3 S3	4	1781	165	10/2001	05/2003	BAM 112
A3 S3	4	1984	195	11/2006	03/2013	BHZ 186 CDLA
A3 S3	4	1984	188	02/2007	03/2013	BZC 186 CDLC
A3 S3	4	1984	221	11/2012	10/2020	CJXC 194 DNUE
A3 S3	4	1984	206	02/2013		CJXB 194
A3 S3	4	1984	210	03/2014		CJXF 194
A3 S3	4	1984	215	05/2014	10/2020	CYFB 194 DJJA
A3 S3	4	1984	228	06/2016	10/2020	CJXG 194 DJHA
A3 S3	4	1984	213	07/2016	10/2020	CJXD 194 DJHB
A3 TDI	4	1598	66	05/2009	03/2013	CAYB 94
A3 TDI	4	1598	77	05/2009		CAYC 96 CLHA 98
A3 TDI	4	1598	81	09/2013		CRKB 98 CXXB DBKA
A3 TDI	4	1598	85	02/2017	10/2020	DDYA 100 DGTE
A3 TDI	4	1896	66	09/1996	07/2001	AGR 134 ALH 140
A3 TDI	4	1896	81	08/1997	07/2001	AHF 136 ASV 142
A3 TDI	4	1896	96	08/2000	05/2003	ASZ 142
A3 TDI	4	1896	74	10/2000	05/2003	ATD 142 AXR
A3 TDI	4	1896	77	05/2003	05/2010	BKC 146 BLS 148 BXE



AUDI	ccm	kW	→	→		
A3 TDI	4	1968	100	05/2003		AZV 148 CBAA 154 CFFA 162 CRBD CRLC
A3 TDI	4	1968	103	05/2003	05/2013	BKD 148 BMM 150 CBAB 154 CBEA CFFB CLJA
A3 TDI	4	1968	125	03/2006	03/2013	BMN 152 CBBB 154 CFGB
A3 TDI	4	1968	120	06/2006	06/2008	BUY 152
A3 TDI	4	1968	110	04/2012		CRBC 162 CRLB 168 CRUA 172 DBGA 174 DCYA DEJA DFGA DSRB D TSA D TSB
A3 TDI	4	1968	105	09/2012	10/2020	CRFC 160
A3 TDI	4	1968	135	12/2012		CUNA 168 DGCA 170
A3 TDI	4	1968	81	01/2013	10/2020	CRFA 160 DEJB 162
A3 TDI	4	1968	85	11/2019		DSUD 172 DTRB 174 DTRD
A3 TDI	4	1968	147	12/2020		DTUA 176
A4	4	1395	110	08/2015	11/2019	CVNA 74
A4	4	1595	74	11/1994	09/2001	ADP 88 AHL 90 ANA ARM
A4	4	1595	75	07/2000	06/2008	ALZ 90
A4	4	1781	92	11/1994	09/2001	ADR 100 APT 108 ARG 110 AVV 114
A4	4	1781	110	01/1995	05/2010	AEB 102 ANB 106 APU 108 ARK 112 ATW 114 AVJ AWT
A4	4	1781	85	04/1995	09/2001	AFY 102
A4	4	1781	132	12/1997	09/2001	AJL 104
A4	4	1781	125	05/2000	12/2005	AMB 106 AWM 114

AUDI	ccm	kW	→	→		
A4	4	1781	127	01/2001	12/2004	AMB 106 AWM 114
A4	4	1781	120	07/2002	03/2009	BFB 116
A4	4	1781	140	11/2002	12/2004	BEX 114
A4	4	1798	118	11/2007	03/2012	CABB 122 CDHB 124
A4	4	1798	88	01/2008	12/2015	CABA 122 CDHA 124
A4	4	1798	125	11/2011	12/2015	CJEB 124
A4	4	1984	96	11/2000	06/2008	ALT 184
A4	4	1984	110	07/2002	11/2019	AWA 184 DLVB 190 DMSB 196
A4	4	1984	147	11/2004	03/2009	BGB 184 BPG BWE BWT
A4	4	1984	162	06/2005	12/2015	BUL 184 CAED 186 CPMB 188
A4	4	1984	149	09/2006	06/2008	BWT 184
A4	4	1984	125	10/2006	10/2019	BPJ 184 BYK 190 CVLA
A4	4	1984	132	06/2008	12/2015	CAEA 186 CDNB 188 CFKA
A4	4	1984	155	06/2008	12/2015	CAEB 186 CDNC 188 CPMA
A4	4	1984	165	05/2013	12/2015	CNCD 190
A4	4	1984	140	05/2015		CVKB 190 DBPA DEMA DKYA DLVA
A4	4	1984	185	05/2015		CYMC 192 CYRB DDWA
A4	4	1984	183	11/2015		CYRC 192 DDWA
A4	4	1984	180	07/2018	11/2019	DKNA 192
A4	4	1984	150	06/2020		DMSA 196
A4	4	1984	195	08/2020		DMTA 196 DPAA 198
A4	6	2393	110	07/1995	07/1997	AFM 208
A4	6	2393	121	03/1997	09/2001	AGA 214 ALF AML APS ARJ

AUDI

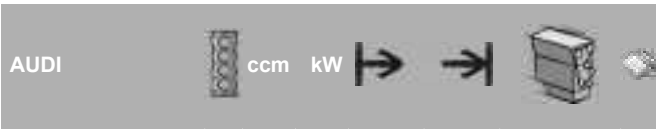

A4	6	2393	120	08/1997	12/2005	AJG 212 AMM 214 APZ
A4	6	2393	125	09/2001	12/2005	BDV 214
A4	6	2598	110	01/1995	09/2001	ABC 226
A4	6	2598	102	01/1996	07/1997	ACZ 230
A4	6	2671	169	02/1999	09/2000	AJK 232
A4	6	2671	185	01/2001	12/2002	APB 234
A4	6	2771	128	01/1995	07/1997	AAH 244 AFC 256
A4	6	2771	142	10/1996	09/2001	ACK 250 AHA 260 ALG 262 AMX APR AQD ATQ
A4	6	2771	140	03/1999	10/2000	ATX 264
A4	6	2976	162	11/2000	12/2005	ASN 312 AVK BGN
A4	6	2976	160	04/2001	07/2006	BBJ 312
A4	6	2976	164	09/2001	12/2005	AVK 312 BGN
A4	6	2995	200	02/2012	12/2015	CMUA 316 CRED 318
A4	6	3123	188	01/2005	03/2009	AUK 320 BKH
A4	6	3123	190	01/2006	06/2008	BKH 320
A4	6	3197	195	11/2007	03/2012	CALA 324
A4 Allroad	4	1984	155	04/2009	05/2016	CDNC 186 CPMA 188
A4 Allroad	4	1984	162	05/2013	05/2016	CPMB 188
A4 Allroad	4	1984	165	05/2013	05/2016	CNCD 190
A4 Allroad	4	1984	185	01/2016		CYMC 192 CYRB 194 DDWA DLHB
A4 Allroad	4	1984	183	05/2016		CYRC 192 DDWA
A4 Allroad	4	1984	180	07/2018		DKNA 192
A4 Allroad	4	1984	195	08/2020		DMTA 196 DPAA 198
A4 Allroad TDI	4	1968	120	04/2009	10/2019	CAHB 152 CGLD 156 CNHC 158 DETB 166
A4 Allroad TDI	4	1968	125	04/2009	05/2016	CAHA 152

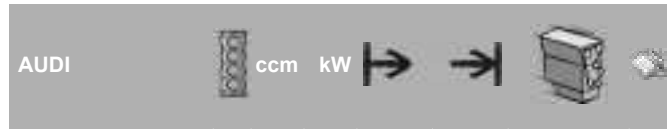

A4 Allroad TDI	4	1968	100	09/2009	07/2018	CAGB 152 CJCB 158 CSUB 160 DEUB 166
A4 Allroad TDI	4	1968	105	09/2009	05/2016	CAGA 152 CJCA 158
A4 Allroad TDI	4	1968	130	11/2011	05/2016	CGLC 156
A4 Allroad TDI	4	1968	110	05/2013	10/2019	CJCD 158 CSUA 160 DEUA 166
A4 Allroad TDI	4	1968	140	09/2013		CNHA 158 DESA 166 DETA 170 DFVA
A4 Allroad TDI	4	1968	150	09/2020		DTPA 174
A4 Allroad TDI	6	2967	176	04/2009	01/2012	CCWA 278
A4 Allroad TDI	6	2967	180	01/2012	05/2016	CDUC 280 CKVB CKVC
A4 Allroad TDI	6	2967	160	01/2016	08/2018	CSWB 298
A4 Allroad TDI	6	2967	200	01/2016	08/2018	CRTC 298
A4 Allroad TDI	6	2967	170	07/2018		DCPE 306
A4 Allroad TDI	6	2967	210	07/2018		DCPC 306
A4 DUO	4	1896	66	03/1998	06/2000	AHU 138
A4 RS4	6	2671	280	05/2000	09/2001	ASJ 236 AZR
A4 RS4	6	2894	331	10/2017	09/2019	DECA 266
A4 RS4	8	4163	309	09/2005	12/2008	BNS 342
A4 RS4	8	4163	331	05/2012	08/2015	CFSA 348
A4 S4	6	2671	195	09/1997	09/2001	AGB 238 AZB
A4 S4	6	2671	187	10/1997	12/2002	APB 234
A4 S4	6	2671	186	11/2000	12/2001	APB 234
A4 S4	6	2995	245	11/2008	12/2015	CAKA 314 CCBA 316 CGWC CGXC CREC CTUB
A4 S4	6	2995	260	05/2016	11/2019	CWGD 318
A4 S4	8	4163	253	03/2003	03/2009	BBK 342 BHF
A4 S4 TDI	6	2967	255	05/2019		DEWB 310
A4 TDI	4	1896	66	01/1995	09/2001	IZ 128 AHH 138 AHU
A4 TDI	4	1896	81	10/1995	09/2001	AFN 132 AVG 144



AUDI	ccm	kW	→	→			
A4 TDI	4	1896	55	12/1995	09/2001	AFF	130
A4 TDI	4	1896	85	03/2000	06/2008	AJM ATJ BKE BRB	142 146
A4 TDI	4	1896	96	11/2000	12/2004	AVF AWX	144
A4 TDI	4	1896	74	05/2001	12/2004	AVB	144
A4 TDI	4	1968	100	11/2004		BNA BRC BRF CAGB CJCB CSUB DEUB DEZB DTNB	150 152 158 160 166 168 172
A4 TDI	4	1968	103	11/2004	03/2009	BLB BPW BRE	150
A4 TDI	4	1968	89	09/2005	09/2006	BVG	150
A4 TDI	4	1968	93	11/2005	11/2006	BVF	150
A4 TDI	4	1968	120	06/2006		BVA CAHB CGLD CNHC DETB DEZE DTNA	150 152 156 158 166 172
A4 TDI	4	1968	125	06/2006	03/2012	BRD CAHA	150 152
A4 TDI	4	1968	105	11/2007	12/2015	CAGA CJCA CMEA CMFA	152 158
A4 TDI	4	1968	88	06/2008	12/2015	CAGC CJCC	152 158
A4 TDI	4	1968	130	11/2011	12/2015	CGLC CMGB	156 158
A4 TDI	4	1968	110	05/2013	11/2019	CJCD CMFB CSUA CZHA DEUA	158 160 166
A4 TDI	4	1968	140	09/2013		CNHA DESA DETA DFVA	158 166 170
A4 TDI	4	1968	90	04/2016	11/2019	DEUC	166
A4 TDI	4	1968	150	05/2020		DTPA	174
A4 TDI	6	2496	110	09/1997	09/2001	AFB AKN	220
A4 TDI	6	2496	132	11/2000	12/2004	AKE BAU BDH	220 222

AUDI	ccm	kW	→	→			
A4 TDI	6	2496	114	08/2001	07/2002	AYM	220
A4 TDI	6	2496	120	07/2002	05/2006	BCZ BDG BFC	222 224
A4 TDI	6	2698	120	11/2005	03/2012	BSG CAMB CGKB	240 242
A4 TDI	6	2698	132	01/2006	03/2009	BPP	240
A4 TDI	6	2698	140	11/2007	03/2012	CAMA CGKA	242
A4 TDI	6	2967	150	11/2004	12/2015	BKN CLAB	274 292
A4 TDI	6	2967	171	01/2006	12/2015	ASB	268
A4 TDI	6	2967	176	11/2007	03/2012	CAPA CCLA CCWA	276 278
A4 TDI	6	2967	155	06/2008	05/2010	CCWB	278
A4 TDI	6	2967	180	11/2011	12/2015	CDUC CKVB CKVC	280
A4 TDI	6	2967	200	05/2015	08/2018	CRTC	298
A4 TDI	6	2967	160	09/2015	08/2018	CSWB	298
A4 TDI	6	2967	170	07/2018	11/2019	DCPE	306
A4 TDI	6	2967	210	07/2018	11/2019	DCPC	306
A5	4	1395	110	11/2016	02/2020	CVNA	74
A5	4	1798	125	10/2007	01/2017	CABD CJEB	122 124
A5	4	1798	118	05/2009	03/2012	CDHB	124
A5	4	1798	106	09/2014	01/2017	CJED	124
A5	4	1798	130	05/2015	01/2017	CJEE	124
A5	4	1984	155	06/2008	01/2017	CAEB CDNC CPMA	186 188
A5	4	1984	132	11/2008	06/2014	CAEA CDNB	186
A5	4	1984	162	03/2012	01/2017	CAED CPMB	186 188
A5	4	1984	165	05/2013	05/2016	CNCD	190
A5	4	1984	169	08/2015	01/2017	CNCE	190
A5	4	1984	183	06/2016	02/2020	CYRC	192
A5	4	1984	185	06/2016		CYMC CYRB DDWA DLHB	192 194

AUDI

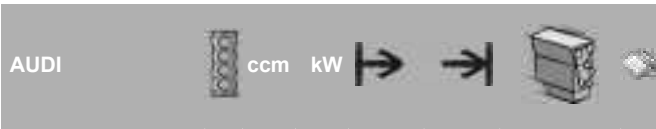

AUDI	ccm	kW				
A5	4	1984	140	09/2016		CVKB 190 DEMA 190 DHDA 190 DKYA 190 DLVA 190
A5	4	1984	125	02/2017		CVLA 190
A5	4	1984	180	07/2018	02/2020	DKNA 192
A5	4	1984	110	08/2018		CVKC 190 DEMB 196 DLVB 196 DMSB 196
A5	4	1984	195	10/2019		DMTA 196 DPAA 198
A5	4	1984	150	05/2020		DMSA 196
A5	6	2894	331	06/2018		DECA 266
A5	6	2995	200	11/2011	01/2017	CHMB 314 CMUA 316 CRED 318
A5	6	3197	195	06/2007	03/2012	CALA 324
A5 RS5	6	2894	331	04/2017		DECA 266
A5 RS5	8	4163	331	03/2010	01/2017	CFSA 348
A5 S5	6	2995	245	06/2009	01/2017	CAKA 314 CCBA 316 CGWC 318 CGXC 318 CREC 318 CTDA 318 CTUB 318
A5 S5	6	2995	249	01/2013	01/2017	CGXC 314
A5 S5	6	2995	260	07/2016		CWGD 318
A5 S5	8	4163	260	06/2007	03/2012	CAUA 346
A5 TDI	4	1968	120	08/2008		CAHB 152 CGLD 156 CNHC 158 DEZE 166 DTNA 172
A5 TDI	4	1968	125	08/2008	03/2012	CAHA 152
A5 TDI	4	1968	100	09/2009		CAGB 152 CJCB 158 CSUB 160 DEUB 166 DEZB 168
A5 TDI	4	1968	105	09/2009	01/2017	CAGA 152 CJCA 158 CMEA 158 CMFA 158
A5 TDI	4	1968	130	10/2011	01/2017	CGLC 156
A5 TDI	4	1968	110	05/2013	02/2020	CJCD 158 CMFB 160 CSUA 166 CZHA 166 DEUA 166

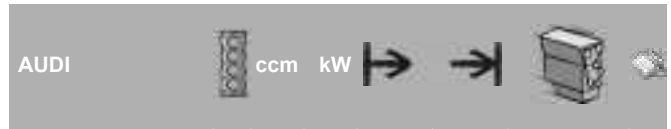

AUDI	ccm	kW				
A5 TDI	4	1968	140	09/2013		CNHA 158 DESA 166 DETA 166
A5 TDI	4	1968	150	09/2020		DTPA 174
A5 TDI	6	2698	140	06/2007	03/2012	CAMA 242 CGKA 242
A5 TDI	6	2698	120	09/2007	03/2012	CAMB 242 CGKB 242
A5 TDI	6	2967	176	06/2007	03/2012	CAPA 276 CCWA 278
A5 TDI	6	2967	155	03/2008	05/2010	CCWB 278
A5 TDI	6	2967	150	10/2011	01/2017	CLAB 292
A5 TDI	6	2967	180	10/2011	01/2017	CDUC 280 CKVB 280 CKVC 280
A5 TDI	6	2967	160	05/2015		CKVD 288 CSWB 298
A5 TDI	6	2967	210	11/2016	02/2020	DCPC 306
A5 TDI	6	2967	200	02/2017	12/2017	CRTC 298
A5 TDI	6	2967	170	07/2018	02/2020	DCPE 306
A5 TDI	6	2967	255	12/2018	02/2020	DEWB 310
A6	4	1781	92	12/1995	12/1997	ADR 100
A6	4	1781	110	01/1997	01/2005	AEB 102 ANB 106 APU 108 ARK 114 AWT 114
A6	4	1781	85	05/1997	01/2005	AFY 102
A6	4	1781	132	12/1997	01/2005	AJL 104
A6	4	1798	140	09/2014	09/2018	CYGA 126
A6	4	1984	74	06/1994	12/1997	AAE 178
A6	4	1984	79	06/1994	07/1995	ADW 184
A6	4	1984	85	06/1994	12/1997	ABK 180
A6	4	1984	103	06/1994	12/1997	ACE 182
A6	4	1984	96	08/2001	01/2005	ALT 184
A6	4	1984	125	06/2005	08/2011	BPJ 184 BYK 184
A6	4	1984	155	03/2011	09/2018	CAEB 186 CHJA 186
A6	4	1984	132	05/2011	09/2018	CDNB 186
A6	4	1984	164	01/2013	09/2018	CAEB 186
A6	4	1984	162	05/2013	09/2018	CAED 186



AUDI	ccm	kW	→	→		
A6	4	1984	185	05/2014		CYNB 190 CYPA 192 DLGA 194 DLHB
A6	4	1984	183	05/2015	09/2018	CYPB 190
A6	4	1984	180	08/2018		DKNA 192 DLHA 194
A6	4	1984	140	02/2019		DKYA 190 DLHC 194
A6	4	1984	220	11/2019		DLGA 192 DRYA 198
A6	4	1984	270	11/2019		DLGA 192
A6	4	1984	195	05/2020		DMTA 196 DPAA 198 DRYA
A6	4	1984	150	09/2020		DMTC 198
A6	5	2309	98	06/1994	12/1995	AAR 204
A6	6	2393	110	07/1995	12/1997	AFM 208
A6	6	2393	115	02/1997	01/2005	APC 210
A6	6	2393	120	02/1997	01/2005	AJG 212 AMM 214 APZ
A6	6	2393	121	02/1997	01/2005	AGA 214 ALF AML APS ARJ
A6	6	2393	100	07/1998	01/2005	ALW 210 ARN ASM
A6	6	2393	125	08/2001	01/2005	BDV 214
A6	6	2393	130	05/2004	10/2008	BDW 216
A6	6	2598	102	06/1994	10/1997	ACZ 230
A6	6	2598	110	06/1994	12/1997	ABC 226
A6	6	2671	169	12/1997	01/2005	AJK 232 AZA 236
A6	6	2671	187	05/2001	07/2004	APB 234 BEL 238
A6	6	2671	184	08/2001	01/2005	ARE 234 BES
A6	6	2671	195	11/2003	07/2004	BEL 238
A6	6	2771	120	06/1994	07/1996	AEJ 254
A6	6	2771	128	06/1994	12/1997	AAH 244 AFC 256

AUDI	ccm	kW	→	→		
A6	6	2771	142	12/1995	10/2008	ACK 250 AHA 260 ALG 262 AMX APR AQD ATQ
A6	6	2771	132	10/1997	05/2000	AGE 258
A6	6	2771	140	07/1999	01/2005	ATX 264
A6	6	2773	154	11/2006	10/2008	BDX 264
A6	6	2773	140	10/2008	08/2011	CCDA 264
A6	6	2773	162	10/2008	09/2018	CCEA 264 CVPA 266
A6	6	2773	150	11/2010	04/2015	CHVA 266
A6	6	2894	331	01/2020		DKMB 268
A6	6	2976	160	06/2001	05/2006	BBJ 312
A6	6	2976	162	08/2001	01/2005	ASN 312
A6	6	2976	164	08/2001	12/2004	AVK 312
A6	6	2995	213	10/2008	08/2011	CAJA 314
A6	6	2995	220	10/2008	05/2012	CCAA 314 CGWB
A6	6	2995	228	03/2011	09/2018	CGWD 314 CGXB 318 CTUA
A6	6	2995	231	01/2013	09/2018	CTUA 318
A6	6	2995	245	09/2014	09/2018	CREC 316
A6	6	2995	250	09/2016		CREH 316 DLZA 320
A6	6	3123	188	05/2004	05/2009	AUK 320 BKH
A6	6	3123	183	09/2006	10/2008	BYU 322
A6	6	3197	195	05/2009	03/2011	CALA 324
A6	8	3697	191	03/1999	01/2005	AQG 328
A6	8	4163	246	05/2004	05/2006	BAT 340 BNK
A6	8	4163	257	06/2006	08/2011	BVJ 344
A6	8	4172	220	11/1998	01/2005	ARS 352 ART ASG AWN
A6 Allroad	6	2995	213	10/2008	08/2011	CAJA 314
A6 Allroad	6	2995	228	01/2012	12/2014	CGWD 314
A6 Allroad	6	2995	245	09/2014	09/2018	CREC 316
A6 Allroad	6	2995	250	11/2019		DLZA 320
A6 Allroad	6	3123	188	05/2006	10/2008	AUK 320

AUDI



AUDI	ccm	kW	→	→		
A6 Allroad	8	4163	257	05/2006	12/2010	BJV 344
A6 Allroad TDI	4	1968	150	09/2020		DTPA 174
A6 Allroad TDI	6	2698	132	03/2006	10/2008	BPP 240
A6 Allroad TDI	6	2698	120	05/2006	08/2011	BSG 240 CAND 242
A6 Allroad TDI	6	2698	140	10/2008	08/2011	CANC 242
A6 Allroad TDI	6	2967	155	05/2006	09/2018	BNG 272 CDYB 278 CRTF 298 CZVC
A6 Allroad TDI	6	2967	171	05/2006	10/2008	ASB 268
A6 Allroad TDI	6	2967	176	10/2008	08/2011	CDYA 278 CDYC
A6 Allroad TDI	6	2967	150	01/2012	12/2014	CLAA 290
A6 Allroad TDI	6	2967	180	01/2012	06/2016	CDUD 280 CKVC 282
A6 Allroad TDI	6	2967	230	01/2012	12/2014	CGQB 284
A6 Allroad TDI	6	2967	235	01/2012	09/2018	CVUA 300
A6 Allroad TDI	6	2967	160	09/2014	09/2018	CRTE 298 CZVA 304
A6 Allroad TDI	6	2967	200	09/2014	09/2018	CRTD 298
A6 Allroad TDI	6	2967	140	11/2015	09/2018	CZVF 298
A6 Allroad TDI	6	2967	170	11/2018		DDVE 312
A6 Allroad TDI	6	2967	210	11/2018		DDVB 312
A6 Allroad TDI	6	2967	257	03/2019		DEWA 310
A6 Allroad TDI	6	2967	183	08/2019		CVMD 298
A6 RS6	8	3993	412	01/2013	09/2018	CRDB 334 CWUB
A6 RS6	8	3993	445	11/2015	09/2018	CWUC 334
A6 RS6	8	3996	441	09/2019		DJPB 334
A6 RS6	8	4172	331	07/2002	01/2005	BCY 352
A6 RS6 plus	8	4172	353	04/2004	01/2005	BRV 352
A6 S6	5	2226	169	06/1994	12/1997	AAN 200
A6 S6	8	3993	309	02/2012	09/2018	CEUC 332
A6 S6	8	3993	331	10/2014	09/2018	CTGE 334
A6 S6	8	4172	213	06/1994	12/1997	AEC 350
A6 S6	8	4172	250	09/1999	01/2005	ANK 352 AQJ BBD
A6 S6	10	5204	320	03/2006	08/2011	BXA 352
A6 S6 plus	8	4172	240	04/1996	12/1997	AHK 350

AUDI	ccm	kW	→	→		
A6 TDI	4	1896	66	06/1994	12/1997	IZ 128 AHU 138
A6 TDI	4	1896	81	04/1997	04/2001	AFN 132 AVG 144
A6 TDI	4	1896	85	07/2000	01/2005	AJM 142
A6 TDI	4	1896	96	08/2001	01/2005	AVF 144 AWX
A6 TDI	4	1968	100	07/2004		BNA 150 BRF 152 CAGB 158 CGL 162 CSUE 164 DDCA 168 DEZF
A6 TDI	4	1968	103	07/2004	10/2008	BLB 150 BRE
A6 TDI	4	1968	89	09/2005	06/2006	BVG 150
A6 TDI	4	1968	125	10/2008	08/2011	CAHA 152
A6 TDI	4	1968	120	04/2009		CAHB 152 CGLD 156 DEZD 166 DTPB 174
A6 TDI	4	1968	130	03/2011	09/2018	CGLC 156 CMGB 158
A6 TDI	4	1968	140	11/2013		CNHA 158 CZJA 164 DDDA 166 DESA
A6 TDI	4	1968	110	09/2014	09/2018	CSUD 162 DDCB 164
A6 TDI	4	1968	150	05/2018		DFBA 168 DTPA 174
A6 TDI	5	2461	85	06/1994	12/1997	AAT 218
A6 TDI	5	2461	103	08/1994	12/1997	AEL 218
A6 TDI	6	2496	110	07/1997	01/2005	AFB 220 AKN
A6 TDI	6	2496	132	02/2000	01/2005	AKE 220 BAU 222 BDH
A6 TDI	6	2496	114	08/2001	01/2005	AYM 220
A6 TDI	6	2496	120	07/2002	01/2005	BCZ 222 BDG 224 BFC
A6 TDI	6	2698	120	11/2004	08/2011	BSG 240 CANB 242 CAND
A6 TDI	6	2698	132	11/2004	10/2008	BPP 240
A6 TDI	6	2698	140	10/2008	08/2011	CANA 242 CANC



AUDI	ccm	kW	→	→		
A6 TDI	6	2967	155	05/2004		BNG 272 CDYB 278 CRTF 296 CTCB 298 CZVC 312 CZVD DDVF
A6 TDI	6	2967	165	05/2004	05/2006	BMK 270
A6 TDI	6	2967	171	06/2006	10/2008	ASB 268
A6 TDI	6	2967	176	10/2008	09/2018	CDYA 278 CDYC 296 CPNB
A6 TDI	6	2967	150	11/2010	09/2018	CLAA 290 CLAB 292
A6 TDI	6	2967	180	03/2011	09/2018	CDUC 280 CDUD 282 CKVB CKVC
A6 TDI	6	2967	230	11/2011	09/2018	CGQB 284
A6 TDI	6	2967	160	09/2014	09/2018	CRTE 296 CTCC 298 CZVA 304 CZVB
A6 TDI	6	2967	200	09/2014	09/2018	CRTD 298
A6 TDI	6	2967	235	09/2014	09/2018	CVUA 300
A6 TDI	6	2967	240	09/2014	09/2018	CVUB 300
A6 TDI	6	2967	210	02/2018		DDVB 312
A6 TDI	6	2967	170	05/2018		DDVE 312
A6 TDI	6	2967	257	03/2019		DEWA 310
A6 TDI	6	2967	183	07/2019		CVMD 298
A7	4	1798	140	04/2015	05/2018	CYGA 126
A7	4	1984	185	09/2014		CYNB 190 CYPA 192 DLGA
A7	4	1984	183	05/2015	05/2018	CYPB 190
A7	4	1984	180	07/2018		DKNA 192 DLHA 194
A7	4	1984	270	07/2019		DRYA 198
A7	4	1984	140	11/2019		DKYA 190
A7	4	1984	220	11/2019		DLGA 192
A7	4	1984	195	05/2020		DMTA 198 DRYA
A7	4	1984	150	08/2020		DMTC 198
A7	6	2498	150	09/2012	03/2015	CLXB 224
A7	6	2773	150	10/2010	03/2015	CHVA 266 CNYA
A7	6	2773	162	09/2014	05/2018	CVPA 266

AUDI	ccm	kW	→	→		
A7	6	2995	220	10/2010	05/2012	CGWB 314 CHMA
A7	6	2995	228	01/2011	03/2015	CGWD 314 CGXB 318 CTTA CTUA
A7	6	2995	245	05/2014	05/2018	CREC 316
A7	6	2995	250	05/2016		CREH 316 DLZA 320
A7 RS7	8	3993	412	10/2013	04/2018	CRDB 334 CWUB
A7 RS7	8	3993	445	11/2015	04/2018	CWUC 334
A7 RS7	8	3996	441	10/2019		DJPB 334
A7 S7	6	2894	331	01/2020		DKMB 268
A7 S7	8	3993	309	02/2012	03/2015	CEUC 332
A7 S7	8	3993	331	07/2014	05/2018	CTGE 334
A7 S7 TDI	6	2967	257	03/2019		DEWA 310
A7 TDI	4	1968	150	09/2018		DFBA 168 DTPA 174
A7 TDI	6	2967	180	10/2010	06/2016	CDUC 280 CDUD 282 CKVB CKVC
A7 TDI	6	2967	150	11/2010	03/2015	CLAA 290 CLAB 292
A7 TDI	6	2967	230	11/2011	03/2015	CGQB 284
A7 TDI	6	2967	176	05/2013	06/2017	CPNB 296
A7 TDI	6	2967	200	05/2014	05/2018	CRTD 298
A7 TDI	6	2967	235	05/2014	05/2018	CVUA 300
A7 TDI	6	2967	155	07/2014		CRTF 296 CTCB 298 CZVC 312 CZVD DDVF
A7 TDI	6	2967	160	07/2014	05/2018	CRTE 296 CTCC 298 CZVA 304 CZVB
A7 TDI	6	2967	240	09/2014	05/2018	CVUB 300
A7 TDI	6	2967	140	11/2015	05/2018	CZVE 298 CZVF
A7 TDI	6	2967	210	10/2017		DDVB 312
A7 TDI	6	2967	170	06/2018		DDVE 312
A8	4	1984	155	02/2012	11/2015	CHJA 186
A8	4	1984	185	09/2016	01/2018	CYPA 190
A8	6	2498	150	07/2012	06/2016	CPAA 224 CVBA

AUDI



AUDI	ccm	kW	→	→		
A8	6	2771	128	03/1994	03/1996	AAH 244
A8	6	2771	120	07/1995	03/1996	AEJ 254
A8	6	2771	142	04/1996	09/2002	ACK 250 ALG 260 AMX 262 APR AQD
A8	6	2773	154	08/2007	07/2010	BDX 264
A8	6	2773	170	01/2009	07/2010	CJBA 264
A8	6	2976	160	07/2003	05/2006	BBJ 312
A8	6	2976	162	07/2003	05/2005	ASN 312
A8	6	2995	245	06/2010	01/2018	CGXC 314 CMDA 316 CREC 318 CTDA CTUB
A8	6	2995	213	07/2010	04/2014	CGWA 314 CGXA 316 CREG
A8	6	2995	228	11/2011	01/2018	CGWD 314 CREA 316
A8	6	2995	250	06/2017		CZSE 320
A8	6	2995	210	07/2018		CZSA 320
A8	6	2995	330	10/2019		CZSE 320
A8	6	3123	191	06/2005	07/2010	BPK 322
A8	8	3697	169	07/1995	12/1998	AEW 328 AKJ
A8	8	3697	191	11/1998	09/2002	AKC 328 AQQ
A8	8	3697	206	10/2002	05/2006	BFL 328
A8	8	3993	309	03/2012	12/2014	CEUA 332
A8	8	3993	320	10/2013	12/2015	CTGA 334
A8	8	3993	331	07/2015	01/2018	CTGF 334
A8	8	3996	338	05/2018		CXYA 334
A8	8	4163	257	06/2006	07/2010	BVJ 344
A8	8	4163	273	11/2009	12/2012	CDRA 346
A8	8	4172	180	03/1994	07/1996	AEM 350
A8	8	4172	220	03/1994	11/1998	ABZ 350 AKG
A8	8	4172	210	07/1995	09/1998	AGH 350
A8	8	4172	228	11/1998	09/2002	AKB 352 AQF AUW AUX
A8	8	4172	175	02/1999	04/2000	ARU 352

AUDI	ccm	kW	→	→		
A8	8	4172	224	09/1999	12/2003	AUX 352
A8	8	4172	231	01/2000	12/2002	AKB 352
A8	8	4172	246	10/2002	07/2010	BFM 352 BGK
A8	12	5998	309	01/2001	09/2002	AZC 354
A8	12	5998	331	12/2003	07/2010	BHT 354 BSB BTE
A8 S8	8	3993	382	04/2012	01/2018	CGTA 332 CTFA 334
A8 S8	8	3993	388	01/2013	04/2014	CGTA 332
A8 S8	8	3993	445	11/2015	01/2018	DDTA 334
A8 S8	8	3996	420	02/2019		CWWB 334
A8 S8	8	4172	250	07/1996	06/1999	AHC 350 AKH
A8 S8	8	4172	265	06/1999	09/2002	AQH 352 AVP AYS BCS
A8 S8	8	4172	268	09/2003	12/2004	AYS 352
A8 S8	10	5204	331	06/2006	07/2010	BSM 352
A8 S8	10	5204	324	09/2006	07/2010	BSM 352
A8 TDI	6	2496	110	01/1997	04/2000	AFB 220 AKN
A8 TDI	6	2496	132	09/2000	09/2002	AKE 220
A8 TDI	6	2967	171	08/2003	07/2010	ASB 268
A8 TDI	6	2967	155	11/2003	11/2015	BNG 272 CDTB 294 CTBB 296
A8 TDI	6	2967	184	07/2010	01/2018	CDTA 294 CDTC CMHA
A8 TDI	6	2967	150	09/2011	09/2013	CLAB 292
A8 TDI	6	2967	176	11/2012	06/2016	CPNA 294 CPNB 296
A8 TDI	6	2967	190	10/2013	01/2018	CTBA 296
A8 TDI	6	2967	193	05/2015	01/2018	CTBD 296
A8 TDI	6	2967	210	06/2017		DDVC 312
A8 TDI	6	2967	183	01/2019		CVMD 298
A8 TDI	8	3328	165	06/2000	09/2002	AKF 326
A8 TDI	8	3936	202	05/2003	07/2005	ASE 328
A8 TDI	8	3956	320	11/2019		CVXB 330
A8 TDI	8	4134	235	01/2005	06/2005	BMC 336
A8 TDI	8	4134	240	07/2005	07/2010	BVN 336



AUDI	ccm	kW	→	→		
A8 TDI	8	4134	258	11/2009	04/2014	CDSB 338
A8 TDI	8	4134	283	10/2013	01/2018	CTEC 338
Allroad	6	2671	184	05/2000	08/2005	ARE 234 BES
Allroad	6	2671	187	09/2000	08/2005	APB 234 BEL 238
Allroad	8	4163	220	07/2002	08/2005	BAS 340
Allroad TDI	6	2496	132	05/2000	08/2005	AKE 220 BAU 222
Allroad TDI	6	2496	120	05/2003	08/2005	BCZ 222
Cabrio	4	1781	92	01/1997	08/2000	ADR 100
Cabrio	4	1984	85	01/1993	07/1998	ABK 180
Cabrio	4	1984	103	06/1995	07/1996	ACE 182
Cabrio	5	2309	98	05/1991	07/1994	NG 204
Cabrio	6	2598	110	06/1993	08/2000	ABC 226
Cabrio	6	2771	128	11/1992	08/2000	AAH 244 AFC 256
Cabrio TDI	4	1896	66	06/1995	08/2000	1Z 128 AHU 138
Coupé	4	1781	55	08/1981	07/1983	DD 120
Coupé	4	1781	66	09/1982	10/1988	DS 120 JV
Coupé	4	1781	82	12/1984	07/1991	DZ 118
Coupé	4	1781	68	01/1985	07/1988	JN 118
Coupé	4	1781	65	04/1986	10/1988	SF 120
Coupé	4	1781	79	08/1986	10/1987	PV 120
Coupé	5	1921	85	08/1980	07/1983	WN 148
Coupé	4	1984	83	05/1989	03/1990	3A 176
Coupé	4	1984	85	05/1989	12/1996	AAD 178 ABK 180
Coupé	4	1984	82	03/1990	07/1990	3A 176
Coupé	4	1984	101	01/1992	07/1992	6A 176
Coupé	4	1984	103	08/1992	12/1996	ACE 182
Coupé	5	1994	118	08/1989	07/1991	NM 198
Coupé	5	2226	85	07/1981	10/1987	KX 202
Coupé	5	2226	88	01/1984	10/1988	JT 202 KX
Coupé	5	2226	100	09/1984	07/1991	HY 202 KV
Coupé	5	2309	98	08/1986	12/1996	NG 204
Coupé	5	2309	97	10/1988	12/1992	NG 204

AUDI	ccm	kW	→	→		
Coupé	5	2309	100	10/1988	07/1994	NG 204
Coupé	5	2309	125	11/1988	07/1991	7A 202
Coupé	5	2309	123	05/1990	12/1996	7A 202
Coupé	6	2598	110	08/1992	12/1996	ABC 226
Coupé	6	2771	128	08/1991	12/1996	AAH 244
Coupé S2	5	2226	162	09/1990	09/1992	3B 200
Coupé S2	5	2226	169	10/1992	12/1996	ABY 200
Q2	3	999	85	10/2016	10/2020	CHZJ 68 DKRF
Q2	3	999	81	08/2020		DAAA 70
Q2	4	1395	110	06/2016	08/2018	CZEA 76
Q2	4	1495	110	07/2018		DADA 80 DPCA
Q2	4	1984	140	05/2017		CZPB 192 DKZA
Q2	4	1984	221	08/2018		DNUE 194
Q2 TDI	4	1598	85	06/2016		DDYA 100 DGTE
Q2 TDI	4	1968	140	07/2016	08/2018	DFHA 168
Q2 TDI	4	1968	110	09/2016		DFGA 162 DTTC 174
Q2 TDI	4	1968	105	11/2016	10/2020	CRFC 160
Q2 TDI	4	1968	85	04/2021		DTRB 174 DTRD
Q3	4	1395	110	10/2013		CHPB 74 CWLA 76 CZDA CZEA DGEA
Q3	4	1395	92	07/2016	10/2018	CZDB 74
Q3	4	1495	110	08/2018		DADA 80 DPCA
Q3	4	1498	110	11/2019		DFYA 80
Q3	4	1984	125	06/2011	04/2015	CCZC 186
Q3	4	1984	155	06/2011	04/2015	CPSA 188
Q3	4	1984	147	09/2014	10/2018	CCTA 186
Q3	4	1984	132	11/2014		CULB 188 CZPA 192 DKTC 194
Q3	4	1984	162	11/2014	10/2018	CULC 188
Q3	4	1984	140	07/2018		DKTC 194 DNNA 196
Q3	4	1984	169	07/2018		DKTA 194
Q3	4	1984	137	02/2019		CZRA 192

AUDI



AUDI	ccm	kW				
Q3	4	1984	170	05/2019		DHHA 192
Q3	4	1984	180	01/2021		DNPA 196
Q3	5	2480	294	10/2019		DAZA 218 DNWA
Q3 RS	5	2480	250	05/2013	10/2018	CZGA 218
Q3 RS	5	2480	228	10/2013	10/2018	CTSA 218
Q3 RS	5	2480	270	01/2015	10/2018	CZGB 218
Q3 TDI	4	1968	120	06/2011	04/2015	CFGD 156
Q3 TDI	4	1968	130	06/2011	10/2018	CFGC CLLB 156
Q3 TDI	4	1968	100	09/2011	10/2018	CFFA 154 CUVB 162 DFTB
Q3 TDI	4	1968	103	09/2011	10/2018	CFFB CLJA 154
Q3 TDI	4	1968	110	11/2014		CUVC 162 DBBA 174 DFGA DFTA D TSA DTSB
Q3 TDI	4	1968	135	11/2014	10/2018	CUWA 168 CYLA DFUA
Q3 TDI	4	1968	88	03/2015	10/2018	CUVD 162 DFTC
Q3 TDI	4	1968	140	10/2018		DFHA 168
Q3 TDI	4	1968	147	09/2020		DTUA 176
Q5	4	1984	155	11/2008	06/2016	CAEB 186 CDNC 188 CHJA CPMA
Q5	4	1984	132	08/2009	05/2017	CDBN 186 CNCB 190
Q5	4	1984	165	06/2012	05/2016	CNCD 190
Q5	4	1984	180	09/2012		CHJA 186 DN TA 196
Q5	4	1984	162	05/2013	05/2017	CPMB 188
Q5	4	1984	169	08/2015	05/2017	CNCE 190
Q5	4	1984	185	06/2016		DAXB 192 DAYB DLGA
Q5	4	1984	183	01/2017	11/2020	DAXC 192
Q5	4	1984	270	08/2019		DLGA 192
Q5	4	1984	195	08/2020		DPUA 198 DPVA DRYA
Q5	4	1984	150	10/2021		DMSA 196

AUDI	ccm	kW				
Q5	6	2995	200	06/2012	05/2017	CTUC 318 CTVA
Q5	6	2995	260	05/2013		CTUD 318 CTXA CWGD
Q5	6	3197	199	11/2008	12/2012	CALB 324
Q5 TDI	4	1968	120	11/2008		CAHB 152 CGLA 156 CGLD 158 CNHC 166 DETB 172 DEZE DTNA
Q5 TDI	4	1968	125	11/2008	09/2012	CAHA 152 CGLB 158 CMGA
Q5 TDI	4	1968	100	08/2009		CAGB 152 CJCB 158 CSUB 160 DEUB 166 DEZB 168
Q5 TDI	4	1968	105	08/2009	05/2013	CAGA 152 CJCA 158
Q5 TDI	4	1968	110	06/2012	11/2020	CJCD 158 CSUA 160 DEUA 166
Q5 TDI	4	1968	130	06/2012	05/2017	CGLC 156 CMGB 158
Q5 TDI	4	1968	140	11/2013		CNHA 158 DESA 166 DETA
Q5 TDI	4	1968	150	11/2019		DFBA 168 DTPA 174
Q5 TDI	6	2967	155	11/2008	09/2012	CCWB 278
Q5 TDI	6	2967	176	11/2008	05/2017	CCWA 278 CPNB 296
Q5 TDI	6	2967	180	06/2012	05/2017	CDUD 282
Q5 TDI	6	2967	184	06/2012	05/2017	CTBC 296
Q5 TDI	6	2967	230	12/2012	11/2015	CGQB 284 CVUC 300
Q5 TDI	6	2967	190	11/2013	05/2017	CTBA 296
Q5 TDI	6	2967	240	04/2015	05/2017	CVUB 300
Q5 TDI	6	2967	250	11/2015	05/2017	DEHA 308
Q5 TDI	6	2967	210	07/2017	11/2020	DCPC 306
Q5 TDI	6	2967	170	08/2018	11/2020	DCPE 306
Q5 TDI	6	2967	255	02/2019		DEWB 310
Q7	4	1984	185	08/2015		CVJA 190 CYMC 192 CYRB
Q7	4	1984	180	03/2020		DMFA 192



AUDI	ccm	kW	→	→		
Q7	6	2995	200	05/2010	08/2015	CJTC CJWC 314
Q7	6	2995	245	05/2010	12/2019	CJTB CJWB CNAAC CREC CTWA 314 316
Q7	6	2995	206	05/2011	08/2015	CJWE CTWB 314
Q7	6	2995	250	07/2019		DCBD DCBE 318
Q7	6	2995	335	11/2019		DCBE 318
Q7	6	3597	206	08/2006	05/2010	BHK 326
Q7	8	3996	373	02/2020		DCUE 334
Q7	8	4163	231	03/2006	12/2010	BAR 340
Q7	8	4163	257	03/2006	05/2010	BAR 340
Q7 TDI	6	2967	155	03/2006	12/2019	BUN CASB CZZB 274 278 304
Q7 TDI	6	2967	171	03/2006	05/2008	BUG 274
Q7 TDI	6	2967	176	11/2007	08/2015	CASA CCMA CJGA CNRB 278 286
Q7 TDI	6	2967	165	06/2009	05/2012	CATA 278
Q7 TDI	6	2967	150	05/2010	08/2015	CJGC CJMA 286
Q7 TDI	6	2967	180	05/2011	08/2015	CJGD CLZB CRCA 286
Q7 TDI	6	2967	200	01/2015	12/2019	CRTC 298
Q7 TDI	6	2967	160	05/2015	12/2019	CRTE CZZA CZZB 298 304
Q7 TDI	6	2967	183	06/2015		CVMD 298
Q7 TDI	6	2967	190	08/2015	12/2019	CUEA CVZA 298 302
Q7 TDI	6	2967	170	07/2018	12/2019	DHXC DPXB 312
Q7 TDI	6	2967	210	07/2018	12/2019	DHXA DPXA 312
Q7 TDI	8	3956	320	04/2016		CZAC DMVA 332
Q7 TDI	8	4134	240	03/2007	06/2009	BTR 336
Q7 TDI	8	4134	250	03/2007	08/2015	CCFA CCFC 338
Q8	4	1984	180	10/2019		DMFA 192

AUDI	ccm	kW	→	→		
Q8	6	2995	250	02/2018		DCBD DCBE 318
Q8	8	3996	441	09/2019		DHUB 334
Q8	8	3996	373	02/2020		DCUE 334
Q8 TDI	6	2967	183	02/2018		CVMD 298
Q8 TDI	6	2967	170	07/2018		DHXC DPXB 312
Q8 TDI	6	2967	210	07/2018		DHXA DPXA 312
QUATTRO	5	2226	89	12/1984	07/1987	JT 202
QUATTRO	5	2226	100	12/1984	07/1987	HY KV 202
QUATTRO Turbo	5	2226	162	08/1989	07/1991	RR 200
R8	8	4163	309	04/2007	09/2010	BYH 344
R8	8	4163	316	07/2010	07/2015	CNDA 348
R8	10	5204	386	04/2009	07/2015	BUJ 352
TT	4	1781	132	10/1998	06/2006	AJQ APP ARY ATC AUQ AWP 110
TT	4	1781	165	10/1998	06/2006	APX BAM 112
TT	4	1781	134	09/1999	06/2006	AWP 110
TT	4	1781	168	09/1999	06/2006	AMU 110
TT	4	1781	110	01/2001	06/2006	AUM 110
TT	4	1781	180	03/2005	06/2006	BFV 116
TT	4	1781	120	09/2005	06/2006	BVP 116
TT	4	1781	140	09/2005	06/2006	BVR 116
TT	4	1798	118	06/2008	06/2014	CDA 122
TT	4	1798	132	07/2015	08/2018	CJSA CJSB 124
TT	4	1984	147	08/2006	06/2010	BPY BWA CCTA CCZA 186
TT	4	1984	149	01/2008	06/2010	CCTA 186
TT	4	1984	195	05/2008	06/2014	CDLA CDMA 186
TT	4	1984	200	05/2008	06/2014	CDLB 186
TT	4	1984	155	05/2010	06/2014	CESA CETA 188
TT	4	1984	169	07/2014		CHHC 194
TT	4	1984	228	11/2014		CJXG 194

AUDI



AUDI ccm kW

TT	4	1984	210	02/2015		CJXF	194
TT	4	1984	162	04/2015		CNTC	194
TT	4	1984	215	07/2015		CYFB DLRA	194
TT	4	1984	145	07/2018		DKZB DNNB	192 196
TT	4	1984	180	07/2018		DKTB	194
TT	4	1984	225	08/2018		DNUF	194
TT	4	1984	170	09/2018		DHHA	192
TT	5	2480	250	07/2009	06/2014	CEPA	218
TT	5	2480	265	05/2011	06/2014	CEPB	218
TT	5	2480	294	10/2016		DAZA DNWA	218
TT	6	3189	184	07/2003	06/2010	BHE BPF BUB CBRA	324
TT TDI	4	1968	125	06/2008	06/2014	CBBB CFGB	154
TT TDI	4	1968	135	07/2014		CUNA	168
V8	8	4172	206	10/1991	02/1994	ABH	348

AUDI



AUDI

AUDI

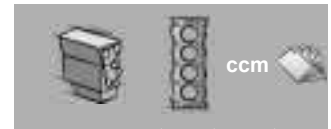
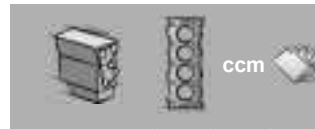
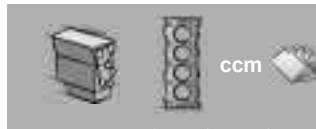

1B	5	2226	202
1T	5	2461	216
1Y	4	1896	128
1Z	4	1896	128
2B	5	2226	202
3A	4	1984	176
3B	5	2226	200
3D	5	2370	206
4B	4	1781	120
6A	4	1984	176
7A	5	2309	202
AAD	4	1984	178
AAE	4	1984	178
AAH	6	2771	244
AAN	5	2226	200
AAR	5	2309	204
AAS	5	2370	206
AAT	5	2461	218
AAZ	4	1896	130
ABB	4	1595	86
ABC	6	2598	226
ABH	8	4172	348
ABK	4	1984	180
ABM	4	1595	86
ABP	5	2461	216
ABT	4	1984	182
ABY	5	2226	200
ABZ	8	4172	350
ACE	4	1984	182
ACK	6	2771	250
ACZ	6	2598	230
ADA	4	1595	88
ADP	4	1595	88
ADR	4	1781	100
ADU	5	2226	200
ADW	4	1984	184
AEB	4	1781	102

AEC	8	4172	350
AEH	4	1595	88
AEJ	6	2771	254
AEL	5	2461	218
AEM	8	4172	350
AEW	8	3697	328
AFB	6	2496	220
AFC	6	2771	256
AFF	4	1896	130
AFM	6	2393	208
AFN	4	1896	132
AFY	4	1781	102
AGA	6	2393	214
AGB	6	2671	238
AGE	6	2771	258
AGH	8	4172	350
AGN	4	1781	104
AGR	4	1896	134
AGU	4	1781	104
AHA	6	2771	260
AHC	8	4172	350
AHF	4	1896	136
AHH	4	1896	138
AHK	8	4172	350
AHL	4	1595	88
AHU	4	1896	138
AJG	6	2393	214
AJK	6	2671	232
AJL	4	1781	104
AJM	4	1896	142
AJQ	4	1781	110
AKB	8	4172	352
AKC	8	3697	328
AKE	6	2496	220
AKF	8	3328	326
AKG	8	4172	350
AKH	8	4172	350

AKJ	8	3697	328
AKL	4	1595	88
AKN	6	2496	220
ALF	6	2393	214
ALG	6	2771	262
ALH	4	1896	140
ALT	4	1984	184
ALW	6	2393	210
ALZ	4	1595	90
AMB	4	1781	106
AMF	3	1422	76
AMK	4	1781	112
AML	6	2393	214
AMM	6	2393	212
AMU	4	1781	110
AMX	6	2771	260
ANA	4	1595	90
ANB	4	1781	106
ANK	8	4172	352
ANY	3	1191	70
APB	6	2671	234
APC	6	2393	210
APF	4	1595	90
APG	4	1781	106
APP	4	1781	110
APR	6	2771	262
APS	6	2393	214
APT	4	1781	108
APU	4	1781	108
APX	4	1781	112
APY	4	1781	112
APZ	6	2393	214
AQA	4	1781	110
AQD	6	2771	262
AQF	8	4172	352
AQG	8	3697	328
AQH	8	4172	352

AQJ	8	4172	352
ARE	6	2671	234
ARG	4	1781	110
ARJ	6	2393	214
ARK	4	1781	108
ARM	4	1595	90
ARN	6	2393	210
ARS	8	4172	352
ART	8	4172	352
ARU	8	4172	352
ARX	4	1781	110
ARY	4	1781	110
ARZ	4	1781	110
ASB	6	2967	268
ASE	8	3936	328
ASG	8	4172	352
ASJ	6	2671	236
ASM	6	2393	210
ASN	6	2976	312
ASV	4	1896	142
ASZ	4	1896	142
ATC	4	1781	110
ATD	4	1896	142
ATJ	4	1896	142
ATL	3	1422	78
ATQ	6	2771	262
ATW	4	1781	112
ATX	6	2771	264
AUA	4	1390	72
AUK	6	3123	320
AUL	4	1781	112
AUM	4	1781	110
AUQ	4	1781	110
AUW	8	4172	352
AUX	8	4172	352
AVB	4	1896	144
AVF	4	1896	144



AVG	4	1896	144
AVJ	4	1781	112
AVK	6	2976	312
AVP	8	4172	352
AVU	4	1595	90
AVV	4	1781	114
AWA	4	1984	184
AWL	4	1781	114
AWM	4	1781	114
AWN	8	4172	352
AWP	4	1781	110
AWT	4	1781	114
AWX	4	1896	144
AXR	4	1896	142
AXW	4	1984	184
AXX	4	1984	186
AYM	6	2496	220
AYS	8	4172	352
AZA	6	2671	236
AZB	6	2671	238
AZC	12	5998	354
AZR	6	2671	236
AZV	4	1968	148
BAD	4	1598	92
BAG	4	1598	94
BAM	4	1781	112
BAR	8	4163	340
BAS	8	4163	340
BAT	8	4163	340
BAU	6	2496	222
BBD	8	4172	352
BBG	6	2771	264
BBJ	6	2976	312
BBK	8	4163	342
BBY	4	1390	72
BCS	8	4172	352
BCY	8	4172	352



BCZ	6	2496	222
BDB	6	3189	324
BDG	6	2496	222
BDH	6	2496	222
BDV	6	2393	214
BDW	6	2393	216
BDX	6	2773	264
BEL	6	2671	238
BES	6	2671	234
BEX	4	1781	114
BFB	4	1781	116
BFC	6	2496	224
BFL	8	3697	328
BFM	8	4172	352
BFQ	4	1595	90
BFV	4	1781	116
BGB	4	1984	184
BGK	8	4172	352
BGN	6	2976	312
BGU	4	1595	90
BHC	3	1422	78
BHE	6	3189	324
BHF	8	4163	342
BHK	6	3597	326
BHT	12	5998	354
BHZ	4	1984	186
BKB	4	1781	114
BKC	4	1896	146
BKD	4	1968	148
BKE	4	1896	146
BKH	6	3123	320
BKN	6	2967	274
BLB	4	1968	150
BLF	4	1598	94
BLP	4	1598	94
BLR	4	1984	184
BLS	4	1896	146



BLX	4	1984	184
BLY	4	1984	184
BMB	4	1984	184
BMC	8	4134	336
BMJ	6	3189	324
BMK	6	2967	270
BMM	4	1968	150
BMN	4	1968	152
BNA	4	1968	150
BND	6	2496	222
BNG	6	2967	272
BNK	8	4163	340
BNS	8	4163	342
BPF	6	3189	324
BPG	4	1984	184
BPJ	4	1984	184
BPK	6	3123	322
BPP	6	2698	240
BPW	4	1968	150
BPY	4	1984	186
BRB	4	1896	146
BRC	4	1968	150
BRD	4	1968	150
BRE	4	1968	150
BRF	4	1968	150
BRV	8	4172	352
BRY	4	1595	90
BSB	12	5998	354
BSE	4	1595	90
BSF	4	1595	90
BSG	6	2698	240
BSM	10	5204	352
BTE	12	5998	354
BTR	8	4134	336
BUB	6	3189	324
BUG	6	2967	274
BUJ	10	5204	352



BUL	4	1984	184
BUN	6	2967	274
BUY	4	1968	152
BVA	4	1968	150
BVF	4	1968	150
BVG	4	1968	150
BVJ	8	4163	344
BVN	8	4134	336
BVP	4	1781	116
BVR	4	1781	116
BVY	4	1984	184
BVZ	4	1984	184
BWA	4	1984	186
BWE	4	1984	184
BWT	4	1984	184
BXA	10	5204	352
BXE	4	1896	148
BYH	8	4163	344
BYK	4	1984	184
BYU	6	3123	322
BZB	4	1798	122
BZC	4	1984	186
CABA	4	1798	122
CABB	4	1798	122
CABD	4	1798	122
CAEA	4	1984	186
CAEB	4	1984	186
CAED	4	1984	186
CAGA	4	1968	152
CAGB	4	1968	152
CAGC	4	1968	152
CAHA	4	1968	152
CAHB	4	1968	152
CAJA	6	2995	314
CAKA	6	2995	314
CALA	6	3197	324
CALB	6	3197	324

AUDI

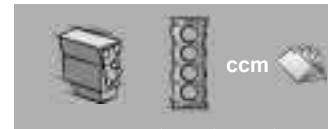
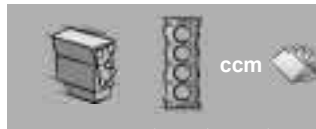
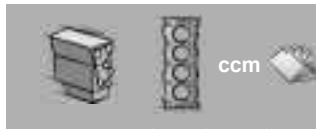

CAMA	6	2698	242
CAMB	6	2698	242
CANA	6	2698	242
CANB	6	2698	242
CANC	6	2698	242
CAND	6	2698	242
CAPA	6	2967	276
CASA	6	2967	278
CASB	6	2967	278
CATA	6	2967	278
CAUA	8	4163	346
CAVG	4	1390	72
CAWB	4	1984	186
CAXA	4	1390	74
CAXC	4	1390	74
CAYB	4	1598	94
CAYC	4	1598	96
CBAA	4	1968	154
CBAB	4	1968	154
CBBB	4	1968	154
CBEA	4	1968	154
CBFA	4	1984	186
CBRA	6	3189	324
CBZA	4	1197	70
CBZB	4	1197	70
CCAA	6	2995	314
CCBA	6	2995	314
CCDA	6	2773	264
CCEA	6	2773	264
CCFA	8	4134	338
CCFC	8	4134	338
CCLA	6	2967	278
CCMA	6	2967	278
CCSA	4	1595	90
CCTA	4	1984	186
CCWA	6	2967	278
CCWB	6	2967	278

CCZA	4	1984	186
CCZC	4	1984	186
CDA A	4	1798	122
CDHA	4	1798	124
CDHB	4	1798	124
CDLA	4	1984	186
CDLB	4	1984	186
CDLC	4	1984	186
CDLH	4	1984	186
CDMA	4	1984	186
CDNA	4	1984	186
CDNB	4	1984	186
CDNC	4	1984	186
CDRA	8	4163	346
CDSB	8	4134	338
CDTA	6	2967	294
CDTB	6	2967	294
CDTC	6	2967	294
CDUC	6	2967	280
CDUD	6	2967	282
CDYA	6	2967	278
CDYB	6	2967	278
CDYC	6	2967	278
CEPA	5	2480	218
CEPB	5	2480	218
CESA	4	1984	188
CETA	4	1984	188
CEUA	8	3993	332
CEUC	8	3993	332
FFFA	4	1968	154
FFFB	4	1968	154
CFGB	4	1968	154
CFG C	4	1968	156
CFGD	4	1968	156
CFHB	4	1968	154
CFHD	4	1968	154
CFKA	4	1984	188

CFSA	8	4163	348
CGKA	6	2698	242
CGKB	6	2698	242
CGLA	4	1968	158
CGLB	4	1968	158
CGLC	4	1968	156
CGLD	4	1968	156
CGLE	4	1968	158
CGQB	6	2967	284
CGTA	8	3993	332
CGWA	6	2995	314
CGWB	6	2995	314
CGWC	6	2995	314
CGWD	6	2995	314
CGXA	6	2995	314
CGXB	6	2995	314
CGXC	6	2995	314
CHHB	4	1984	194
CHHC	4	1984	194
CHJA	4	1984	186
CHMA	6	2995	314
CHMB	6	2995	314
CHPB	4	1395	74
CHVA	6	2773	266
CHZB	3	999	68
CHZD	3	999	68
CHZE	3	999	68
CHZJ	3	999	68
CHZL	3	999	68
CJBA	6	2773	264
CJCA	4	1968	158
CJCB	4	1968	158
CJCC	4	1968	158
CJCD	4	1968	158
CJEB	4	1798	124
CJED	4	1798	124
CJEE	4	1798	124

CJGA	6	2967	286
CJGC	6	2967	286
CJGD	6	2967	286
CJMA	6	2967	286
CJSA	4	1798	124
CJSB	4	1798	124
CJTB	6	2995	314
CJTC	6	2995	314
CJWB	6	2995	314
CJWC	6	2995	314
CJWE	6	2995	314
CJXB	4	1984	194
CJXC	4	1984	194
CJXD	4	1984	194
CJXF	4	1984	194
CJXG	4	1984	194
CJZA	4	1197	72
CJZB	4	1197	72
CKVB	6	2967	280
CKVC	6	2967	280
CKVD	6	2967	288
CLAA	6	2967	290
CLAB	6	2967	292
CLHA	4	1598	98
CLJA	4	1968	154
CLLB	4	1968	156
CLXA	6	2498	224
CLXB	6	2498	224
CLZB	6	2967	286
CMBA	4	1395	74
CMDA	6	2995	314
CMEA	4	1968	152
CMFA	4	1968	158
CMFB	4	1968	158
CMGA	4	1968	158
CMGB	4	1968	158
CMHA	6	2967	294



CMSA	4	1390	74
CMUA	6	2995	318
CMXA	4	1595	90
CNAA	6	2995	314
CNCB	4	1984	190
CNCD	4	1984	190
CNCE	4	1984	190
CNDA	8	4163	348
CNHA	4	1968	158
CNHC	4	1968	158
CNRB	6	2967	286
CNSB	4	1798	124
CNTC	4	1984	194
CNUA	4	1390	72
CNVA	4	1390	74
CNYA	6	2773	266
CNYB	6	2773	266
CPAA	6	2498	224
CPMA	4	1984	188
CPMB	4	1984	188
CPNA	6	2967	294
CPNB	6	2967	296
CPSA	4	1984	188
CPTA	4	1395	76
CPWA	4	1395	74
CR	4	1588	82
CRBC	4	1968	162
CRBD	4	1968	162
CRCA	6	2967	286
CRDB	8	3993	334
CREA	6	2995	316
CREC	6	2995	316
CRED	6	2995	316
CREG	6	2995	316
CREH	6	2995	316
CRFA	4	1968	160
CRFC	4	1968	160



CRKB	4	1598	98
CRLB	4	1968	162
CRLC	4	1968	162
CRTC	6	2967	298
CRTD	6	2967	298
CRTE	6	2967	304
CRTF	6	2967	298
CRUA	4	1968	162
CSUA	4	1968	160
CSUB	4	1968	160
CSUD	4	1968	162
CSUE	4	1968	162
CSWB	6	2967	298
CTBA	6	2967	296
CTBB	6	2967	296
CTBC	6	2967	296
CTBD	6	2967	296
CTCB	6	2967	296
CTCC	6	2967	296
CTDA	6	2995	318
CTEC	8	4134	338
CTFA	8	3993	334
CTGA	8	3993	334
CTGE	8	3993	334
CTGF	8	3993	334
CTHG	4	1390	72
CTJA	4	1390	72
CTSA	5	2480	218
CTTA	6	2995	318
CTUA	6	2995	318
CTUB	6	2995	314
CTUC	6	2995	318
CTUD	6	2995	318
CTVA	6	2995	318
CTWA	6	2995	314
CTWB	6	2995	314
CTXA	6	2995	318



CUEA	6	2967	298
CUKB	4	1395	74
CULB	4	1984	188
CULC	4	1984	188
CUNA	4	1968	168
CUPA	4	1968	168
CUSB	3	1422	78
CUVB	4	1968	162
CUVC	4	1968	162
CUVD	4	1968	162
CUWA	4	1968	168
CVBA	6	2498	224
CVJA	4	1984	190
CVKB	4	1984	190
CVKC	4	1984	190
CVLA	4	1984	190
CVMD	6	2967	298
CVNA	4	1395	74
CVPA	6	2773	266
CVUA	6	2967	300
CVUB	6	2967	300
CVUC	6	2967	300
CVXB	8	3956	330
CVZA	6	2967	302
CWGD	6	2995	318
CWLA	4	1395	74
CWUB	8	3993	334
CWUC	8	3993	334
CWWB	8	3996	334
CWZA	4	1984	194
CXMA	4	1598	98
CXSA	4	1395	74
CXSB	4	1395	74
CXUA	4	1395	74
CXXB	4	1598	98
CXYA	8	3996	334
CY	4	1588	82



CYFB	4	1984	194
CYGA	4	1798	126
CYLA	4	1968	168
CYMC	4	1984	192
CYNB	4	1984	190
CYPA	4	1984	190
CYPB	4	1984	190
CYRB	4	1984	192
CYRC	4	1984	192
CYVA	4	1197	72
CYVB	4	1197	72
CZAA	8	3956	332
CZAC	8	3956	332
CZCA	4	1395	74
CZCC	4	1395	74
CZDA	4	1395	74
CZDB	4	1395	74
CZDD	4	1395	74
CZEA	4	1395	76
CZGA	5	2480	218
CZGB	5	2480	218
CZHA	4	1968	166
CZJA	4	1968	164
CZPA	4	1984	192
CZPB	4	1984	192
CZPC	4	1984	192
CZRA	4	1984	192
CZSA	6	2995	320
CZSE	6	2995	320
CZVA	6	2967	298
CZVB	6	2967	298
CZVC	6	2967	298
CZVD	6	2967	298
CZVE	6	2967	298
CZVF	6	2967	298
CZZA	6	2967	298
CZZB	6	2967	304

AUDI

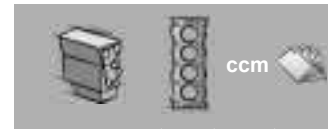
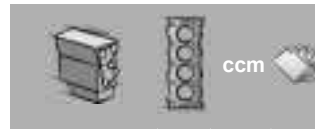
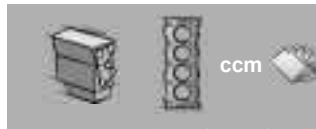

DADA	4	1495	80
DAJB	4	1798	126
DAXB	4	1984	192
DAXC	4	1984	192
DAYB	4	1984	192
DAZA	5	2480	218
DBBA	4	1968	162
DBGA	4	1968	168
DBKA	4	1598	98
DBPA	4	1984	190
DCBD	6	2995	318
DCBE	6	2995	318
DCPC	6	2967	306
DCPE	6	2967	306
DCUE	8	3996	334
DCYA	4	1968	162
DD	4	1781	120
DDCA	4	1968	164
DDCB	4	1968	164
DDDA	4	1968	164
DDTA	8	3993	334
DDVB	6	2967	312
DDVC	6	2967	312
DDVE	6	2967	312
DDVF	6	2967	312
DDWA	4	1984	192
DDYA	4	1598	100
DDYB	4	1598	98
DECA	6	2894	266
DEHA	6	2967	308
DEJA	4	1968	162
DEJB	4	1968	162
DEMA	4	1984	190
DEMB	4	1984	190
DESA	4	1968	166
DETA	4	1968	166
DETB	4	1968	166



DEUA	4	1968	166
DEUB	4	1968	166
DEUC	4	1968	166
DEWA	6	2967	310
DEWB	6	2967	310
DEZB	4	1968	168
DEZD	4	1968	166
DEZE	4	1968	166
DEZF	4	1968	168
DFBA	4	1968	168
DFGA	4	1968	162
DFHA	4	1968	168
DFTA	4	1968	162
DFTB	4	1968	162
DFTC	4	1968	162
DFUA	4	1968	168
DFVA	4	1968	170
DFYA	4	1498	80
DGCA	4	1968	170
DGEA	4	1395	76
DGTE	4	1598	100
DHDA	4	1984	190
DHFA	4	1498	80
DHHA	4	1984	192
DHUB	8	3996	334
DHXA	6	2967	312
DHXC	6	2967	312
DJHA	4	1984	194
DJHB	4	1984	194
DJJA	4	1984	194
DJPB	8	3996	334
DKJA	3	999	68
DKLA	3	999	70
DKLD	3	999	70
DKMB	6	2894	268
DKNA	4	1984	192
DKRF	3	999	68

DKTA	4	1984	194
DKTB	4	1984	194
DKTC	4	1984	194
DKYA	4	1984	190
DKZA	4	1984	192
DKZB	4	1984	192
DKZC	4	1984	192
DLAA	3	999	70
DLAC	3	999	70
DLGA	4	1984	192
DLHA	4	1984	194
DLHB	4	1984	194
DLHC	4	1984	194
DLRA	4	1984	194
DLVA	4	1984	190
DLVB	4	1984	190
DLZA	6	2995	320
DMFA	4	1984	192
DMFB	4	1984	192
DMSA	4	1984	196
DMSB	4	1984	196
DMTA	4	1984	198
DMTC	4	1984	198
DMVA	8	3956	332
DNNA	4	1984	196
DNNB	4	1984	196
DNND	4	1984	196
DNPA	4	1984	196
DNTA	4	1984	196
DNUE	4	1984	194
DNUF	4	1984	194
DNWA	5	2480	218
DNWC	5	2480	218
DPAA	4	1984	196
DPCA	4	1495	80
DPUA	4	1984	198
DPVA	4	1984	198





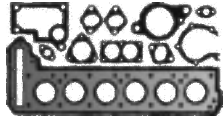
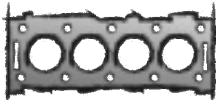

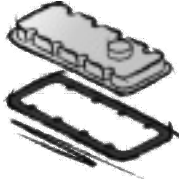
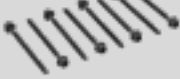
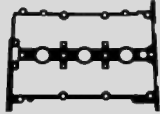
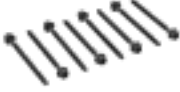
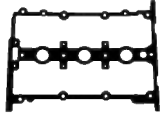
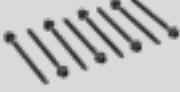
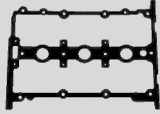
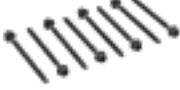
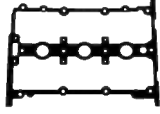

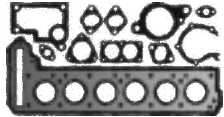
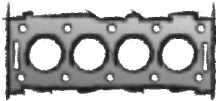

DPXA	6	2967	312
DPXB	6	2967	312
DR	4	1781	120
DRYA	4	1984	198
DS	4	1781	120
DSRB	4	1968	172
DSUD	4	1968	172
DT	4	1595	92
DTA	4	1595	92
DTNA	4	1968	172
DTNB	4	1968	172
DTPA	4	1968	174
DTPB	4	1968	174
DTRB	4	1968	174
DTRD	4	1968	174
DTSA	4	1968	174
DTSB	4	1968	174
DTTC	4	1968	174
DTUA	4	1968	176
DZ	4	1781	118
EP	4	1297	72
HX	5	2226	202
HY	5	2226	202
JK	4	1588	84
JN	4	1781	118
JT	5	2226	202
JU	4	1595	92
JV	4	1781	120
JW	4	1781	120
KU	5	2226	202
KV	5	2226	202
KX	5	2226	202
KZ	5	2226	202
MC	5	2226	202
NC	5	1986	198
NE	4	1781	120
NF	5	2309	204

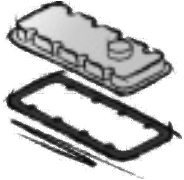
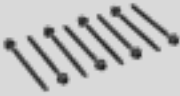
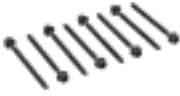
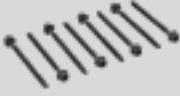











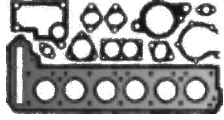
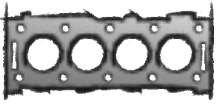

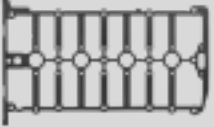

NG	5	2309	204
NM	5	1994	198
NP	4	1781	120
PH	4	1781	120
PM	4	1781	120
PP	4	1595	92
PR	5	2226	202
PS	5	1994	200
PV	4	1781	120
PX	5	2226	202
RA	4	1588	84
RN	4	1595	92
RR	5	2226	200
RS	4	1781	120
RT	5	1994	200
RU	4	1781	120
SA	4	1595	92
SB	4	1588	84
SD	4	1847	126
SF	4	1781	120
SH	4	1781	120
WH	5	1921	148
WN	5	1921	148

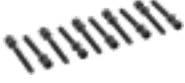





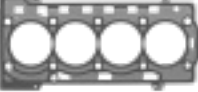
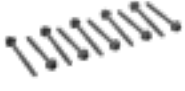















<p>AUDI</p> 				
<p>CHZB CHZE</p> <p>3 Cyl. 999 ccm Cyl. 74,5 Ø</p> <p>A1</p> <p>03/2015 → 10/2018</p>	<p>ES⊕ 459.200 CS 308.590</p>	<p>456.550 04C 103 383 K</p>	<p>ZKS 445.890 WHT 007 089 (8x) M 9x1,25x140</p> 	<p>322.980 04C 103 483 E</p> 
<p>CHZD</p> <p>3 Cyl. 999 ccm Cyl. 74,5 Ø</p> <p>A3</p> <p>07/2016 → 10/2020</p>	<p>ES⊕ 779.610 CS 308.590</p>	<p>397.150 04C 103 383 AB 0,72 mm $\frac{3}{4}$ 75,5 Ø</p>	<p>ZKS 445.890 WHT 007 089 (8x) M 9x1,25x140</p> 	<p>322.980 04C 103 483 E</p> 
<p>CHZJ CHZL</p> <p>3 Cyl. 999 ccm Cyl. 74,5 Ø</p> <p>Q2</p> <p>10/2016 → 10/2020</p>	<p>ES⊕ 459.200 →10/2015 ES⊕ 779.610 10/2015→ CS 308.590</p>	<p>456.550 04C 103 383 K →10/2015 397.150 04C 103 383 AB 0,72 mm $\frac{3}{4}$ 75,5 Ø 10/2015→</p>	<p>ZKS 445.890 WHT 007 089 (8x) M 9x1,25x140</p> 	<p>322.980 04C 103 483 E</p> 
<p>DKJA DKRF</p> <p>3 Cyl. 999 ccm Cyl. 74,5 Ø</p> <p>A1</p> <p>07/2018 →</p> <p>A3</p> <p>07/2016 → 10/2020</p> <p>Q2</p> <p>07/2018 → 10/2020</p>	<p>ES⊕ 779.610 07/2019→ CS 308.590</p>	<p>397.150 04C 103 383 AB 0,72 mm $\frac{3}{4}$ 75,5 Ø</p>	<p>ZKS 445.890 WHT 007 089 (8x) M 9x1,25x140</p> 	<p>065.810 04C 103 383 K →06/2019 322.980 04C 103 483 E 07/2019→</p> 







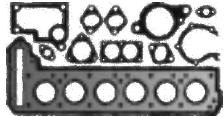
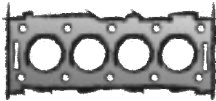

			<p>a) </p> <p>b) </p>	<p>K: </p> <p>N: </p>	
<p>302.890 04E 109 675 FPM E 6x</p> <p>308.610 04E 109 675 A FPM A 6x</p>	<p>035.670 04C 253 039 B</p> 	<p>470.370 036 129 717 E 3x</p> 	<p>a) 030.793 Dirko HT</p> <p>b) 591.840 N 013 815.8 Metal C 14x20x2</p> <p>b) 813.036 N 013 815.6 CU C 14x20x2</p>	<p>K:← 248.270 04C 103 085 ASW RD PTFE 30x40x7</p> <p>K:→ 523.120 04E 103 170 A IWD LD PTFE/ACM 85</p> <p>N:← 242.650 04E 103 085 AF ASW RD PTFE/ACM 36x46x7 2x</p> <p>N:→ 242.620 04E 103 085 ASW LD PTFE 24x39x8</p>	<p>TLS 633.760</p>
<p>302.890 04E 109 675 FPM E 6x</p> <p>308.610 04E 109 675 A FPM A 6x</p>	<p>035.670 04C 253 039 B</p> 	<p>470.370 036 129 717 E 3x</p> 	<p>a) 030.793 Dirko HT</p> <p>b) 591.840 N 013 815.8 Metal C 14x20x2</p> <p>b) 813.036 N 013 815.6 CU C 14x20x2</p>	<p>K:← 248.270 04C 103 085 ASW RD PTFE 30x40x7</p> <p>K:→ 523.120 04E 103 170 A IWD LD PTFE/ACM 85</p> <p>N:← 242.650 04E 103 085 AF ASW RD PTFE/ACM 36x46x7 2x</p> <p>N:→ 242.620 04E 103 085 ASW LD PTFE 24x39x8</p>	<p>TLS 633.760</p>
<p>302.890 04E 109 675 FPM E 6x</p> <p>308.610 04E 109 675 A FPM A 6x</p>	<p>035.670 04C 253 039 B</p> 	<p>470.370 036 129 717 E 3x</p> 	<p>a) 030.793 Dirko HT</p> <p>b) 591.840 N 013 815.8 Metal C 14x20x2</p> <p>b) 813.036 N 013 815.6 CU C 14x20x2</p>	<p>K:← 248.270 04C 103 085 ASW RD PTFE 30x40x7</p> <p>K:→ 523.120 04E 103 170 A IWD LD PTFE/ACM 85</p> <p>N:← 242.650 04E 103 085 AF ASW RD PTFE/ACM 36x46x7 2x</p> <p>N:→ 242.620 04E 103 085 ASW LD PTFE 24x39x8</p>	<p>TLS 633.760</p>
<p>302.890 04E 109 675 FPM E 6x</p> <p>308.610 04E 109 675 A FPM A 6x</p>	<p>035.670 04C 253 039 B</p> 	<p>470.370 036 129 717 E 3x</p> 	<p>a) 030.793 Dirko HT</p> <p>b) 591.840 N 013 815.8 Metal C 14x20x2</p> <p>b) 813.036 N 013 815.6 CU C 14x20x2</p>	<p>K:← 248.270 04C 103 085 ASW RD PTFE 30x40x7</p> <p>K:→ 523.120 04E 103 170 A IWD LD PTFE/ACM 85</p> <p>N:← 242.650 04E 103 085 AF ASW RD PTFE/ACM 36x46x7 2x</p> <p>N:→ 242.620 04E 103 085 ASW LD PTFE 24x39x8</p>	<p>TLS 633.760</p>

<p>AUDI</p> 				
<p>DKLA</p> <p>3 Cyl. 999 ccm Cyl. 74,5 Ø</p> <p>A1</p> <p>11/2018 →</p>	<p>CS 308.590</p>	<p>397.150 04C 103 383 AB 0,72 mm $\frac{3}{4}$ 75,5 Ø</p>	<p>ZKS 445.890 WHT 007 089 (8x) M 9x1,25x140</p> 	
<p>DKLD</p> <p>3 Cyl. 999 ccm Cyl. 74,5 Ø</p> <p>A1</p> <p>03/2015 → 10/2018</p>	<p>CS 308.590</p>	<p>397.150 04C 103 383 AB 0,72 mm $\frac{3}{4}$ 75,5 Ø 10/2015 →</p>	<p>ZKS 445.890 WHT 007 089 (8x) M 9x1,25x140</p> 	<p>065.810 04C 103 383 K</p>
<p>DLAA DLAC</p> <p>3 Cyl. 999 ccm Cyl. 74,5 Ø</p> <p>A1</p> <p>11/2018 →</p> <p>A3</p> <p>06/2020 →</p> <p>Q2</p> <p>08/2020 →</p>			<p>ZKS 445.890 WHT 007 089 (8x) M 9x1,25x140</p> 	
<p>ANY</p> <p>3 Cyl. 1191 ccm Cyl. 76,5 Ø</p> <p>A2 TDI</p> <p>03/2001 → 08/2005</p>	<p>ES⊕ 473.491</p> 	<p>383.290 045 103 383 C 1,45 mm $\frac{3}{4}$ 77,5 Ø 1 ⊗ </p> <p>383.300 045 103 383 D 1,53 mm $\frac{3}{4}$ 77,5 Ø 2 ⊗ </p> <p>383.320 045 103 383 E 1,61 mm $\frac{3}{4}$ 77,5 Ø 3 ⊗ </p>		<p>ZKHS 515.110</p>  <p>458.370 045 103 483 C</p> 
<p>CBZA CBZB</p> <p>4 Cyl. 1197 ccm Cyl. 71,0 Ø</p> <p>A1</p> <p>05/2010 → 04/2015</p> <p>A3</p> <p>03/2010 → 05/2013</p>	<p>ES⊕ 313.661 CS* 275.150</p>	<p>228.400 03F 103 383 E 71,8 Ø </p>	<p>ZKS 228.470 WHT 004 790 (10x) M 9x1,25x168</p> 	<p>461.682 EL-Liq 74 →07/2011</p> <p>305.900 03F 103 483 A 07/2011 →</p>

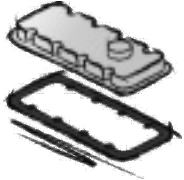
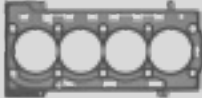
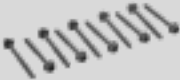

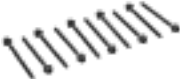
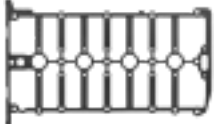

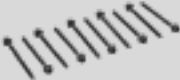
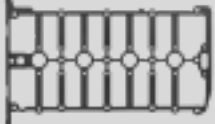

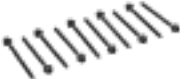
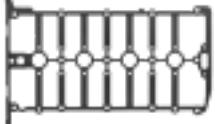













			<p>a) </p> <p>b) </p>	<p>K: </p> <p>N: </p>	
<p>302.890 04E 109 675 FPM E 6x</p> <p>308.610 04E 109 675 A FPM A 6x</p>	<p>035.670 04C 253 039 B</p>	<p>470.370 036 129 717 E 3x</p>	<p>a) 030.793 Dirko HT</p> <p>b) 591.840 N 013 815.8 Metal C 14x20x2</p> <p>b) 813.036 N 013 815.6 CU C 14x20x2</p>	<p>K:← 248.270 04C 103 085 ASW RD PTFE 30x40x7</p> <p>K:→ 523.120 04E 103 170 A IWD LD PTFE/ACM 85</p> <p>N:← 242.650 04E 103 085 AF ASW RD PTFE/ACM 36x46x7 2x</p> <p>N:→ 242.620 04E 103 085 ASW LD PTFE 24x39x8</p>	TLS 633.760
<p>302.890 04E 109 675 FPM E 6x</p> <p>308.610 04E 109 675 A FPM A 6x</p>	<p>035.670 04C 253 039 B</p>	<p>470.370 036 129 717 E 3x</p>	<p>a) 030.793 Dirko HT</p> <p>b) 591.840 N 013 815.8 Metal C 14x20x2</p> <p>b) 813.036 N 013 815.6 CU C 14x20x2</p>	<p>K:← 248.270 04C 103 085 ASW RD PTFE 30x40x7</p> <p>K:→ 523.120 04E 103 170 A IWD LD PTFE/ACM 85</p> <p>N:← 242.650 04E 103 085 AF ASW RD PTFE/ACM 36x46x7 2x</p> <p>N:→ 242.620 04E 103 085 ASW LD PTFE 24x39x8</p>	TLS 633.760
<p>302.890 04E 109 675 FPM E 6x</p> <p>308.610 04E 109 675 A FPM A 6x</p>	<p>035.670 04C 253 039 B</p>	<p>470.370 036 129 717 E 3x</p>	<p>a) 030.793 Dirko HT</p> <p>b) 591.840 N 013 815.8 Metal C 14x20x2</p>	<p>K:← 248.270 04C 103 085 ASW RD PTFE 30x40x7</p> <p>N:← 242.650 04E 103 085 AF ASW RD PTFE/ACM 36x46x7 2x</p> <p>N:→ 242.620 04E 103 085 ASW LD PTFE 24x39x8</p>	
<p>701.289 027 109 675 FPM 6x</p>	<p>530.800 045 253 039</p>	<p>530.810 045 129 717</p>	<p>a) 030.793 Dirko HT</p> <p>b) 567.640 N 908 132 01 M 14x1,5x22</p>	<p>K:← 155.560 038 103 085 E ASW RD PTFE/ACM 35x48x10</p> <p>N:← 129.780 038 103 085 C ASW RD PTFE/ACM 32x47x10</p>	
<p>724.590 036 109 675 A FPM 8x</p>	<p>299.670 03F 253 041 Q</p>	<p>AAS 236.660</p>	<p>a) 030.793 Dirko HT</p> <p>b) 567.640 N 908 132 01 M 14x1,5x22</p>	<p>K:← 129.780 038 103 085 C ASW RD PTFE/ACM 32x47x10</p> <p>K:→ 381.640 036 103 171 B IWD LD PTFE/ACM 85</p>	

AUDI					
					
CJZA CYVA 4 Cyl. 1197 ccm Cyl. 71,0 Ø A3 02/2013 →	CJZB CYVB 4 Cyl. 1197 ccm Cyl. 71,0 Ø A3 02/2013 →	ES⊕ 453.351 CS* 523.430	721.982 04E 103 383 AJ 72 Ø	ZKS 445.910 WHT 007 089 (10x) M 9x1,25x140 	898.042 04E 103 483 H 
EP 4 Cyl. 1297 ccm Cyl. 75,0 Ø 80 09/1978 → 07/1986	EP 4 Cyl. 1297 ccm Cyl. 75,0 Ø 80 09/1978 → 07/1986	ES⊕ 558.908 056 198 012 G 08/1983→ CS* 774.731 037 198 011 C	818.828 049 103 383 M 1,75 mm $\frac{1}{4}$ 78,5 Ø →07/1983 892.564 056 103 383 L 1,75 mm $\frac{1}{4}$ 78,5 Ø 08/1983→  	ZKS 819.808 049 103 385 (10x) M 11x1,5x98 	ZKHS 314.773 026 198 025 A centr. 8,5 mm  ZKHS 457.200 026 198 025 C centr. 6,5 mm  447.050 026 103 483 F 
AUA BBY 4 Cyl. 1390 ccm Cyl. 76,5 Ø A2 02/2000 → 08/2005	AUA BBY 4 Cyl. 1390 ccm Cyl. 76,5 Ø A2 02/2000 → 08/2005	ES⊕ 167.770 CS 303.951	148.331 036 103 383 AM 0,64 mm $\frac{1}{4}$ 77,5 Ø 	ZKS 803.740 036 103 384 B (10x) M 9x1,25x140 	461.682 EL-Liq 74 725.210 03C 103 196 A 4x 
CAVG CTHG 4 Cyl. 1390 ccm Cyl. 76,5 Ø A1 01/2011 → 04/2015	CNUA CTJA 4 Cyl. 1390 ccm Cyl. 76,5 Ø A1 01/2011 → 04/2015	ES⊕ 236.760 CS* 246.680	732.841 03C 103 383 AH 0,90 mm $\frac{1}{4}$ 77,8 Ø 	ZKS 730.300 WHT 000 912 (10x) M 9x1,25x102 	461.682 EL-Liq 74 725.210 03C 103 196 A 4x 

			<p>a) </p> <p>b) </p>	<p>K: </p> <p>N: </p>	
<p>302.890 04E 109 675 FPM E 8x</p> <p>308.610 04E 109 675 A FPM A 8x</p>	<p>223.440 04E 253 039 E</p> 	<p>470.370 036 129 717 E 4x</p> 	<p>a) 030.793 Dirko HT</p> <p>b) 591.840 N 013 815.8 Metal C 14x20x2</p> <p>b) 813.036 N 013 815.6 CU C 14x20x2</p>	<p>K:← 248.270 04C 103 085 ASW RD PTFE 30x40x7</p> <p>K:→ 523.120 04E 103 170 A IWD LD PTFE/ACM 85</p> <p>N:← 242.650 04E 103 085 AF ASW RD PTFE/ACM 36x46x7 2x</p> <p>N:→ 242.620 04E 103 085 ASW LD PTFE 24x39x8</p>	<p>TLS 595.180</p> 
<p>VAS 702.706 FPM</p> <p>553.190 026 109 675 FPM 8x</p>	<p>815.187 028 129 589 B 4x</p> 	<p>AAS 195.670 026 129 717 D +035 121 171 C</p>  <p>460.745 035 121 171 C</p>  <p>757.756 026 129 717 D</p> 	<p>a) 248.097 028 103 609 A</p>  <p>a) 495.620 044 103 609 D</p>  <p>b) 878.070 N 906 606 01 incl. 115.100 M 14x1,5x16</p> <p>b) 115.100 N 013 849.2 CU A 14x20x1,5</p>	<p>K:← 325.155 068 103 085 E ASW WD FPM/ACM 32x47x10</p> <p>K:→ 342.093 068 103 051 P ASW LD FPM 85x105x11</p> <p>K:→ 829.056 068 198 171 ASW LD FPM 85x105x11</p> <p>N:← 325.155 068 103 085 E ASW WD FPM/ACM 32x47x10</p>	
<p>VAS 235.610 FPM</p> <p>724.590 036 109 675 A FPM 16x</p>	<p>135.230 036 253 039 F</p> 	<p>470.370 036 129 717 E 4x</p> 	<p>a) 030.793 Dirko HT</p> <p>b) 567.640 N 908 132 01 M 14x1,5x22</p>	<p>K:← 158.060 036 103 085 H AW/BS RD FPM 32x42x6</p> <p>K:→ 458.821 030 103 171 L IWD LD PTFE 85</p> <p>N:← 076.110 036 103 085 A AW/BS RD FPM 27x42x8 2x</p>	
<p>VAS 235.610 FPM</p> <p>724.590 036 109 675 A FPM 16x</p>	<p>490.240 03C 253 039 F</p> 	<p>151.140 03C 129 717 C</p> 	<p>a) 030.793 Dirko HT</p> <p>b) 567.640 N 908 132 01 M 14x1,5x22</p>	<p>K:← 155.560 038 103 085 E ASW RD PTFE/ACM 35x48x10</p> <p>K:→ 381.640 036 103 171 B IWD LD PTFE/ACM 85</p>	<p>TLS 240.050</p> 

AUDI 					
CAXA CMSA 4 Cyl. 1390 ccm Cyl. 76,5 Ø A1 05/2010 → 04/2015 A3 09/2007 → 05/2013	CAXC CNVA ES⊕ 741.800 CS* 246.680	492.641 03C 103 383 AM 0,80 mm $\frac{1}{4}$ 77,7 Ø 	ZKS 730.300 WHT 000 912 (10x) M 9x1,25x102 	461.682 EL-Liq 74 725.210 03C 103 196 A 4x 	
CVNA 4 Cyl. 1395 ccm Cyl. 74,5 Ø A4 08/2015 → 11/2019 A5 11/2016 → 02/2020	ES⊕ 446.900 CS* 523.430	311.040 04E 103 383 CA 0,80 mm $\frac{1}{4}$ 75,5 Ø	ZKS 445.910 WHT 007 089 (10x) M 9x1,25x140 	898.042 04E 103 483 H 	
CHPB CPWA CXSA CZCA CZDA CZDD 4 Cyl. 1395 ccm Cyl. 74,5 Ø A1 11/2014 → 10/2018 A3 04/2012 → Q3 10/2013 →	CMBA CWLA CXSB CZCC CZDB ES⊕ 352.421 CS* 523.430	721.972 04E 103 383 AM 1,02 mm $\frac{1}{4}$ 75,5 Ø 	ZKS 445.910 WHT 007 089 (10x) M 9x1,25x140 	898.042 04E 103 483 H 	
CUKB CXUA 4 Cyl. 1395 ccm Cyl. 74,5 Ø A3 05/2014 → 10/2020	ES⊕ 352.421 ES⊕ 774.910 USA CS* 523.430	721.972 04E 103 383 AM 1,02 mm $\frac{1}{4}$ 75,5 Ø  898.272 04E 103 383 BL 1,02 mm $\frac{1}{4}$ 75,5 Ø	ZKS 445.910 WHT 007 089 (10x) M 9x1,25x140 	898.042 04E 103 483 H 	

AUDI

			<p>a) </p> <p>b) </p>	<p>K: </p> <p>N: </p>	
<p>VAS 235.610 FPM 724.590 036 109 675 A FPM 16x</p>	<p>490.240 03C 253 039 F </p>	<p>151.140 03C 129 717 C </p>	<p>a) 030.793 Dirko HT</p> <p>b) 567.640 N 908 132 01 M 14x1,5x22</p>	<p>K:← 155.560 038 103 085 E ASW RD PTFE/ACM 35x48x10</p> <p>K:→ 381.640 036 103 171 B IWD LD PTFE/ACM 85</p>	<p>TLS 214.600 </p>
<p>302.890 04E 109 675 FPM E 8x</p> <p>308.610 04E 109 675 A FPM A 8x</p>	<p>223.440 04E 253 039 E </p>	<p>470.370 036 129 717 E 4x </p>	<p>a) 030.793 Dirko HT ↑</p> <p>a) 478.660 04E 103 609 </p> <p>b) 588.690 06L 103 801</p>	<p>K:← 248.270 04C 103 085 ASW RD PTFE 30x40x7</p> <p>K:→ 523.120 04E 103 170 A IWD LD PTFE/ACM 85</p> <p>N:← 242.650 04E 103 085 AF ASW RD PTFE/ACM 36x46x7 2x</p> <p>N:→ 242.620 04E 103 085 ASW LD PTFE 24x39x8</p>	
<p>302.890 04E 109 675 FPM E 8x</p> <p>308.610 04E 109 675 A FPM A 8x</p>	<p>223.440 04E 253 039 E </p>	<p>470.370 036 129 717 E 4x </p>	<p>a) 030.793 Dirko HT</p> <p>b) 591.840 N 013 815.8 Metal C 14x20x2</p> <p>b) 813.036 N 013 815.6 CU C 14x20x2</p>	<p>K:← 248.270 04C 103 085 ASW RD PTFE 30x40x7</p> <p>K:→ 523.120 04E 103 170 A IWD LD PTFE/ACM 85</p> <p>N:← 242.650 04E 103 085 AF ASW RD PTFE/ACM 36x46x7 2x</p> <p>N:→ 242.620 04E 103 085 ASW LD PTFE 24x39x8</p>	<p>TLS 595.180 </p>
<p>302.890 04E 109 675 FPM E 8x</p> <hr/> <p>E A 16x</p> <p>308.610 04E 109 675 A FPM A 8x</p>	<p>223.440 04E 253 039 E </p>	<p>470.370 036 129 717 E 4x </p>	<p>a) 030.793 Dirko HT</p> <p>b) 591.840 N 013 815.8 Metal C 14x20x2</p> <p>b) 813.036 N 013 815.6 CU C 14x20x2</p>	<p>K:← 248.270 04C 103 085 ASW RD PTFE 30x40x7</p> <p>K:→ 523.120 04E 103 170 A IWD LD PTFE/ACM 85</p> <p>N:← 242.650 04E 103 085 AF ASW RD PTFE/ACM 36x46x7 2x</p> <p>N:→ 242.620 04E 103 085 ASW LD PTFE 24x39x8</p>	<p>TLS 595.180 </p>

AUDI

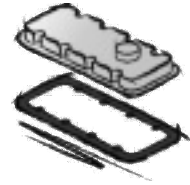
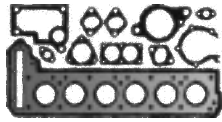

CPTA
CZEA

4 Cyl. **1395 ccm**
Cyl. 74,5 Ø

A1
04/2012 → 10/2018
A3
03/2013 →
Q2
06/2016 → 08/2018
Q3
10/2013 → 10/2018

ES⊕ **774.960**
CS* **523.430**

721.972
04E 103 383 AM
1,02 mm $\frac{3}{8}$ 75,5 Ø

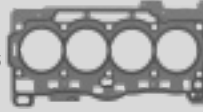

ZKS 445.910
WHT 007 089 (10x)
M 9x1,25x140

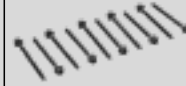

898.042
04E 103 483 H

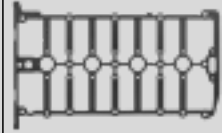

DGEA

4 Cyl. **1395 ccm**
Cyl. 74,5 Ø

A3
05/2014 →
Q3
11/2020 →

ES⊕ **352.421**

721.972
04E 103 383 AM
1,02 mm $\frac{3}{8}$ 75,5 Ø

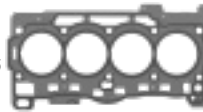

ZKS 445.910
WHT 007 089 (10x)
M 9x1,25x140

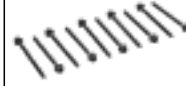

898.042
04E 103 483 H

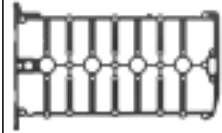

AMF

3 Cyl. **1422 ccm**
Cyl. 79,5 Ø

A2 TDI
02/2000 → 08/2005

ES⊕ **473.491**

CS* **720.420**

149.992
045 103 383 AA
 0,910 mm
→
1,000 mm
1,49 mm $\frac{3}{8}$ 80,7 Ø
1 ⊗



150.011
045 103 383 AB
 1,010 mm
→
1,100 mm
1,53 mm $\frac{3}{8}$ 80,7 Ø
2 ⊗

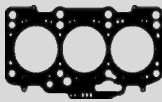

150.021
045 103 383 AC
 1,110 mm
→
1,200 mm
1,61 mm $\frac{3}{8}$ 80,7 Ø
3 ⊗

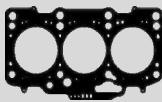

ZKS 057.260
038 103 384 (8x)
M 12x1,75x172



















ZKHS 515.110



458.370
045 103 483 C



			<p>a) </p> <p>b) </p>	<p>K: </p> <p>N: </p>	
<p>302.890 04E 109 675 FPM E 8x</p> <p>308.610 04E 109 675 A FPM A 8x</p>	<p>223.440 04E 253 039 E</p> 	<p>470.370 036 129 717 E 4x</p> 	<p>a) 030.793 Dirko HT</p> <p>b) 591.840 N 013 815.8 Metal C 14x20x2</p> <p>b) 813.036 N 013 815.6 CU C 14x20x2</p>	<p>K:← 248.270 04C 103 085 ASW RD PTFE 30x40x7</p> <p>K:→ 523.120 04E 103 170 A IWD LD PTFE/ACM 85</p> <p>N:← 242.650 04E 103 085 AF ASW RD PTFE/ACM 36x46x7 2x</p> <p>N:→ 523.650 04E 103 085 C ASW LD PTFE/ACM 28x39x7</p>	<p>TLS 595.180</p> 
<p>302.890 04E 109 675 FPM E 8x</p> <p>308.610 04E 109 675 A FPM A 8x</p>	<p>223.440 04E 253 039 E</p> 	<p>470.370 036 129 717 E 4x</p> 	<p>a) 030.793 Dirko HT</p> <p>b) 591.840 N 013 815.8 Metal C 14x20x2</p> <p>b) 813.036 N 013 815.6 CU C 14x20x2</p>	<p>K:← 248.270 04C 103 085 ASW RD PTFE 30x40x7</p> <p>N:← 242.650 04E 103 085 AF ASW RD PTFE/ACM 36x46x7 2x</p> <p>N:→ 242.620 04E 103 085 ASW LD PTFE 24x39x8</p>	<p>TLS 595.180</p> 
<p>701.289 027 109 675 FPM 6x</p>	<p>530.800 045 253 039</p> 	<p>530.810 045 129 717</p> 	<p>a) 030.793 Dirko HT</p> <p>b) 567.640 N 908 132 01 M 14x1,5x22</p>	<p>K:← 155.560 038 103 085 E ASW RD PTFE/ACM 35x48x10</p> <p>K:→ 012.370 06A 103 171 A IWD LD PTFE/ACM 85</p> <p>N:← 129.780 038 103 085 C ASW RD PTFE/ACM 32x47x10</p>	<p>TLS 703.950</p> 

AUDI

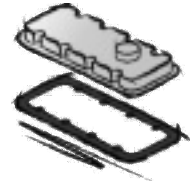

ATL
3 Cyl. **1422 ccm**
Cyl. 79,5 Ø

A2 TDI
11/2003 → 08/2005

ES⊕ **473.491**

CS* **720.420**

149.992
045 103 383 AA
 0,910 mm
→
1,000 mm
1,49 mm $\frac{+}{-}$ 80,7 Ø
1 ⊗



150.011
045 103 383 AB
 1,010 mm
→
1,100 mm
1,53 mm $\frac{+}{-}$ 80,7 Ø
2 ⊗



150.021
045 103 383 AC
 1,110 mm
→
1,200 mm
1,61 mm $\frac{+}{-}$ 80,7 Ø
3 ⊗

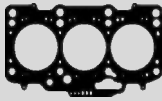

ZKS **057.260**
038 103 384 (8x)
M 12x1,75x172



ZKHS **515.110**



458.370
045 103 483 C



BHC
3 Cyl. **1422 ccm**
Cyl. 79,5 Ø

A2 TDI
02/2000 → 08/2005

ES⊕ **473.491**

CS* **720.420**

149.992
045 103 383 AA
 0,910 mm
→
1,000 mm
1,49 mm $\frac{+}{-}$ 80,7 Ø
1 ⊗



150.011
045 103 383 AB
 1,010 mm
→
1,100 mm
1,53 mm $\frac{+}{-}$ 80,7 Ø
2 ⊗

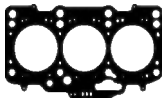

150.021
045 103 383 AC
 1,110 mm
→
1,200 mm
1,61 mm $\frac{+}{-}$ 80,7 Ø
3 ⊗

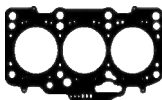

ZKS **057.260**
038 103 384 (8x)
M 12x1,75x172



ZKHS **515.110**



458.370
045 103 483 C



CUSB
3 Cyl. **1422 ccm**
Cyl. 79,5 Ø

A1 TDI
11/2014 → 10/2018

ES⊕ **523.440**

CS **785.070**

219.570
04B 103 383 AA
 0,910 mm
→
1,000 mm
1,55 mm $\frac{+}{-}$ 80,8 Ø
1 ⊗



219.580
04B 103 383 AB
 1,010 mm
→
1,100 mm
1,63 mm $\frac{+}{-}$ 80,8 Ø
2 ⊗



219.590
04B 103 383 AC
 1,110 mm
→
1,200 mm
1,71 mm $\frac{+}{-}$ 80,8 Ø
3 ⊗



ZKS **527.770**
WHT 005 673 (8x)
M 12x1,75x206





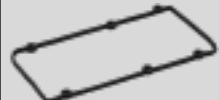













461.682
EL-Liq 74
↓
453.820
04B 103 483 C



455.150
04B 103 070 A
3x

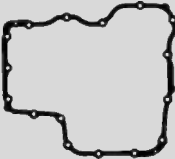

			<p>a) </p> <p>b) </p>	<p>K: </p> <p>N: </p>	
<p>701.289 027 109 675 FPM 6x</p>	<p>530.800 045 253 039</p> 	<p>530.810 045 129 717</p> 	<p>a) 030.793 Dirko HT</p> <p>b) 567.640 N 908 132 01 M 14x1,5x22</p>	<p>K:← 155.560 038 103 085 E ASW RD PTFE/ACM 35x48x10</p> <p>K:→ 012.370 06A 103 171 A IWD LD PTFE/ACM 85</p> <p>N:← 129.780 038 103 085 C ASW RD PTFE/ACM 32x47x10</p>	
<p>701.289 027 109 675 FPM 6x</p>	<p>530.800 045 253 039</p> 	<p>530.810 045 129 717</p> 	<p>a) 030.793 Dirko HT</p> <p>b) 567.640 N 908 132 01 M 14x1,5x22</p>	<p>K:← 155.560 038 103 085 E ASW RD PTFE/ACM 35x48x10</p> <p>K:→ 012.370 06A 103 171 A IWD LD PTFE/ACM 85</p> <p>N:← 129.780 038 103 085 C ASW RD PTFE/ACM 32x47x10</p>	<p>TLS 196.620</p> 
<p>VAS 424.780 724.590 036 109 675 A FPM 12x</p>	<p>214.171 04B 253 039 C</p>	<p>523.390 04B 129 717</p> 	<p>a) 220.750 04B 103 609</p>  <p>a) 030.793 Dirko HT ↑</p>	<p>K:← 377.450 03L 103 085 B AW RD PTFE/ACM 35x48x10</p> <p>N:← 897.690 03L 103 085 AW RD PTFE/ACM 32x47x10</p>	<p>TLS 651.020</p> 

AUDI

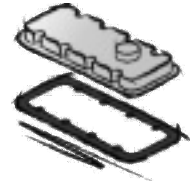

DADA
DPCA

4 Cyl. **1495 ccm**
Cyl. 74,5 Ø

A1 09/2018 →
A3 05/2017 →
Q2 07/2018 →
Q3 08/2018 →

ES⊕ **877.090**
CS* **928.960**

523.821
04E 103 383 CC
0,72 mm \pm 76,5 Ø

ZKS 445.910
WHT 007 089 (10x)
M 9x1,25x140



471.650
04E 103 483 S

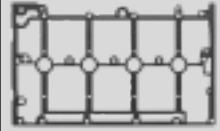

DFYA

4 Cyl. **1498 ccm**
Cyl. 74,5 Ø

A3 04/2020 →
Q3 11/2019 →

ES⊕ **877.090**
CS* **928.960**

523.821
04E 103 383 CC
0,72 mm \pm 76,5 Ø

ZKS 445.910
WHT 007 089 (10x)
M 9x1,25x140

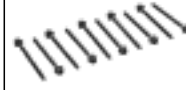

471.650
04E 103 483 S

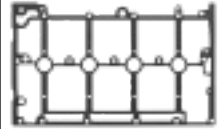

DHFA

4 Cyl. **1498 ccm**
Cyl. 74,5 Ø

A3 11/2018 →

ES⊕ **448.400**

792.020
05E 103 383
0,72 mm \pm 75,5 Ø

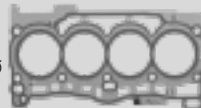







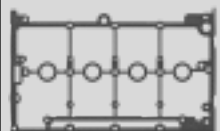









ZKS 445.910
WHT 007 089 (10x)
M 9x1,25x140



793.630
05E 103 483



			<p>a) </p> <p>b) </p>	<p>K: </p> <p>N: </p>	
<p>302.890 04E 109 675 FPM E 8x</p> <p>308.610 04E 109 675 A FPM A 8x</p>	<p>223.440 04E 253 039 E</p> 	<p>470.370 036 129 717 E 4x</p> 	<p>a) 030.793 Dirko HT</p> <p>b) 591.840 N 013 815.8 Metal C 14x20x2</p> <p>b) 813.036 N 013 815.6 CU C 14x20x2</p>	<p>K:← 248.270 04C 103 085 ASW RD PTFE 30x40x7</p> <p>K:→ 523.120 04E 103 170 A IWD LD PTFE/ACM 85</p> <p>N:← 242.650 04E 103 085 AF ASW RD PTFE/ACM 36x46x7 2x</p> <p>N:← 814.110 04E 103 085 AN ASW LD FPM 55x67x8</p> <p>N:→ 523.650 04E 103 085 C ASW LD PTFE/ACM 28x39x7</p>	<p>TLS 877.100</p> 
<p>302.890 04E 109 675 FPM E 8x</p> <p>308.610 04E 109 675 A FPM A 8x</p>	<p>223.440 04E 253 039 E</p> 	<p>470.370 036 129 717 E 4x</p> 	<p>a) 030.793 Dirko HT</p> <p>b) 591.840 N 013 815.8 Metal C 14x20x2</p> <p>b) 813.036 N 013 815.6 CU C 14x20x2</p>	<p>K:← 248.270 04C 103 085 ASW RD PTFE 30x40x7</p> <p>K:→ 523.120 04E 103 170 A IWD LD PTFE/ACM 85</p> <p>N:← 242.650 04E 103 085 AF ASW RD PTFE/ACM 36x46x7 2x</p> <p>N:← 814.110 04E 103 085 AN ASW LD FPM 55x67x8</p> <p>N:→ 523.650 04E 103 085 C ASW LD PTFE/ACM 28x39x7</p>	<p>TLS 877.100</p> 
<p>302.890 04E 109 675 FPM E 8x</p> <p>308.610 04E 109 675 A FPM A 8x</p>	<p>223.440 04E 253 039 E</p> 	<p>470.370 036 129 717 E 4x</p> 	<p>a) 030.793 Dirko HT</p> <p>b) 591.840 N 013 815.8 Metal C 14x20x2</p> <p>b) 813.036 N 013 815.6 CU C 14x20x2</p>	<p>K:← 248.270 04C 103 085 ASW RD PTFE 30x40x7</p> <p>K:→ 523.120 04E 103 170 A IWD LD PTFE/ACM 85</p> <p>N:← 242.650 04E 103 085 AF ASW RD PTFE/ACM 36x46x7 2x</p> <p>N:← 814.110 04E 103 085 AN ASW LD FPM 55x67x8</p> <p>N:→ 523.650 04E 103 085 C ASW LD PTFE/ACM 28x39x7</p>	<p>TLS 877.100</p> 

AUDI

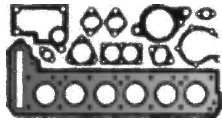

CR
4 Cyl. **1588 ccm**
Cyl. 76,5 Ø
80
08/1980 → 08/1986

S⊕* **086.887**
068 198 001
ES⊕ **827.606**
068 198 012 L
CS* **774.731**
037 198 011 C



285.023
068 103 383 FM
0,820 mm
→
0,920 mm
1,55 mm $\frac{2}{3}$ 78,5 Ø
2 ⊗
Mot. CR 176 339→



285.040
068 103 383 FN
0,920 mm
→
1,020 mm
1,70 mm $\frac{2}{3}$ 78,5 Ø
3 ⊗
Mot. CR 176 339→



ZKS **819.832**
056 103 385 A (10x)
M 11x1,5x98
→Mot. CR 176 338



ZKS **819.824**
068 103 384 A (10x)
M 12x1,75x115
Mot. CR 176 339→

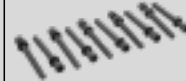

ZKHS **314.773**
026 198 025 A
centr. 8,5 mm



ZKHS **457.200**
026 198 025 C
centr. 6,5 mm



447.050
026 103 483 F

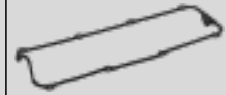

CY
4 Cyl. **1588 ccm**
Cyl. 76,5 Ø
80 TD
08/1981 → 05/1986
90 TD
10/1985 → 01/1987

ES⊕ **827.606**
068 198 012 L
CS* **774.731**
037 198 011 C



285.023
068 103 383 FM
0,820 mm
→
0,920 mm
1,55 mm $\frac{2}{3}$ 78,5 Ø
2 ⊗
→07/1985



285.040
068 103 383 FN
0,920 mm
→
1,020 mm
1,70 mm $\frac{2}{3}$ 78,5 Ø
3 ⊗
→07/1985



891.348
068 103 383 EH
0,662 mm
→
0,860 mm
1,53 mm $\frac{2}{3}$ 78,5 Ø
1 ⊗
08/1985→

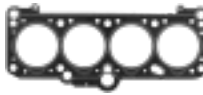

891.356
068 103 383 EJ
0,870 mm
→
0,920 mm
1,57 mm $\frac{2}{3}$ 78,5 Ø
2 ⊗
08/1985→



891.364
068 103 383 EK
0,930 mm
→
1,020 mm
1,61 mm $\frac{2}{3}$ 78,5 Ø
3 ⊗
08/1985→



ZKS **819.824**
068 103 384 A (10x)
M 12x1,75x115

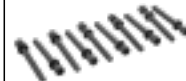

ZKHS **314.773**
026 198 025 A
centr. 8,5 mm



















ZKHS **457.200**
026 198 025 C
centr. 6,5 mm

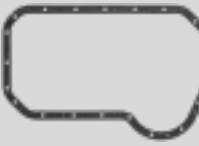

447.050
026 103 483 F



AUDI

			<p>a) </p> <p>b) </p>	<p>K: </p> <p>N: </p>	
<p>VAS 702.706 FPM 553.190 026 109 675 FPM 8x</p>	<p>815.187 028 129 589 B 4x</p> 	<p>757.756 026 129 717 D</p> 	<p>a) 248.097 028 103 609 A</p>  <p>a) 495.620 044 103 609 D</p>  <p>b) 878.070 N 906 606 01 incl. 115.100 M 14x1,5x16</p> <p>b) 115.100 N 013 849.2 CU A 14x20x1,5</p>	<p>K:← 325.155 068 103 085 E ASW WD FPM/ACM 32x47x10</p> <p>K:→ 342.093 068 103 051 P ASW LD FPM 85x105x11</p> <p>K:→ 829.056 068 198 171 ASW LD FPM 85x105x11</p> <p>N:← 325.155 068 103 085 E ASW WD FPM/ACM 32x47x10</p>	
<p>VAS 702.706 FPM 553.190 026 109 675 FPM 8x</p>	<p>815.187 028 129 589 B 4x</p> 	<p>757.756 026 129 717 D →07/1985</p>  <p>893.242 068 129 717 E 08/1985→</p> 	<p>a) 248.097 028 103 609 A</p>  <p>a) 495.620 044 103 609 D</p>  <p>b) 878.070 N 906 606 01 incl. 115.100 M 14x1,5x16</p> <p>b) 115.100 N 013 849.2 CU A 14x20x1,5</p>	<p>K:← 325.155 068 103 085 E ASW WD FPM/ACM 32x47x10</p> <p>K:→ 342.093 068 103 051 P ASW LD FPM 85x105x11</p> <p>K:→ 829.056 068 198 171 ASW LD FPM 85x105x11</p> <p>N:← 325.155 068 103 085 E ASW WD FPM/ACM 32x47x10</p>	

AUDI

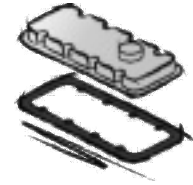
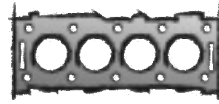
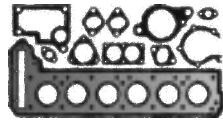





JK
4 Cyl. **1588 ccm**
Cyl. 76,5 Ø

80
08/1980 → 07/1989

S⊕* **086.887**
068 198 001

ES⊕ **827.606**
068 198 012 L

CS* **774.731**
037 198 011 C

285.023
068 103 383 FM
 0,820 mm → 0,920 mm
1,55 mm $\frac{1}{2}$ 78,5 Ø
2 ⊗
→07/1985
285.040
068 103 383 FN
 0,920 mm → 1,020 mm
1,70 mm $\frac{1}{2}$ 78,5 Ø
3 ⊗
→07/1985
891.348
068 103 383 EH
 0,662 mm → 0,860 mm
1,53 mm $\frac{1}{2}$ 78,5 Ø
1 ⊗
08/1985→
891.356
068 103 383 EJ
 0,870 mm → 0,920 mm
1,57 mm $\frac{1}{2}$ 78,5 Ø
2 ⊗
08/1985→
891.364
068 103 383 EK
 0,930 mm → 1,020 mm
1,61 mm $\frac{1}{2}$ 78,5 Ø
3 ⊗
08/1985→

ZKS 819.824
068 103 384 A (10x)
M 12x1,75x115



ZKHS 314.773
026 198 025 A
centr. 8,5 mm



ZKHS 457.200
026 198 025 C
centr. 6,5 mm

447.050
026 103 483 F





RA SB
4 Cyl. **1588 ccm**
Cyl. 76,5 Ø



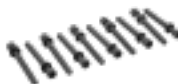



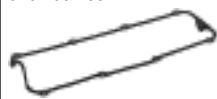







80 TD
09/1986 → 08/1991
90 TD
04/1987 → 09/1991

ES⊕ **827.606**
068 198 012 L

CS* **774.731**
037 198 011 C

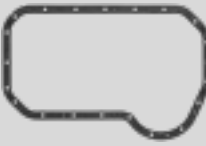
891.348
068 103 383 EH
 0,662 mm → 0,860 mm
1,53 mm $\frac{1}{2}$ 78,5 Ø
1 ⊗
891.356
068 103 383 EJ
 0,870 mm → 0,920 mm
1,57 mm $\frac{1}{2}$ 78,5 Ø
2 ⊗
891.364
068 103 383 EK
 0,930 mm → 1,020 mm
1,61 mm $\frac{1}{2}$ 78,5 Ø
3 ⊗

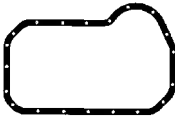
ZKS 819.824
068 103 384 A (10x)
M 12x1,75x115

ZKHS 314.773
026 198 025 A
centr. 8,5 mm

ZKHS 457.200
026 198 025 C
centr. 6,5 mm

447.050
026 103 483 F

			<p>a) </p> <p>b) </p>	<p>K: </p> <p>N: </p>	
<p>VAS 702.706 FPM 553.190 026 109 675 FPM 8x</p>	<p>815.187 028 129 589 B 4x</p> 	<p>757.756 026 129 717 D</p> 	<p>a) 248.097 028 103 609 A</p>  <p>a) 495.620 044 103 609 D</p>  <p>b) 878.070 N 906 606 01 incl. 115.100 M 14x1,5x16</p> <p>b) 115.100 N 013 849.2 CU A 14x20x1,5</p>	<p>K:← 325.155 068 103 085 E ASW WD FPM/ACM 32x47x10</p> <p>K:→ 342.093 068 103 051 P ASW LD FPM 85x105x11</p> <p>K:→ 829.056 068 198 171 ASW LD FPM 85x105x11</p> <p>N:← 325.155 068 103 085 E ASW WD FPM/ACM 32x47x10</p>	
<p>VAS 702.706 FPM 553.190 026 109 675 FPM 8x</p>	<p>815.187 028 129 589 B 4x</p> 	<p>893.242 068 129 717 E</p> 	<p>a) 248.097 028 103 609 A</p>  <p>a) 495.620 044 103 609 D</p>  <p>b) 878.070 N 906 606 01 incl. 115.100 M 14x1,5x16</p> <p>b) 115.100 N 013 849.2 CU A 14x20x1,5</p>	<p>K:← 325.155 068 103 085 E ASW WD FPM/ACM 32x47x10</p> <p>K:→ 342.093 068 103 051 P ASW LD FPM 85x105x11</p> <p>K:→ 829.056 068 198 171 ASW LD FPM 85x105x11</p> <p>N:← 325.155 068 103 085 E ASW WD FPM/ACM 32x47x10</p>	

AUDI



ABB
4 Cyl. **1595 ccm**
Cyl. 81,0 Ø
80
08/1990 → 10/1991

ES⊕ **834.300**
026 198 012 S
CS* **774.731**
037 198 011 C

828.807
026 103 383 S
1,75 mm $\frac{\pm}{\pm}$ 83 Ø

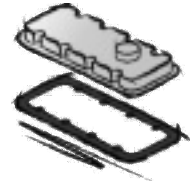

ZKS **819.817**
050 103 384 (10x)
M 11x1,5x96



ZKHS **314.773**
026 198 025 A
centr. 8,5 mm



ZKHS **457.200**
026 198 025 C
centr. 6,5 mm



447.050
026 103 483 F

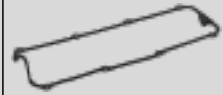

ABM
4 Cyl. **1595 ccm**
Cyl. 81,0 Ø
80
09/1991 → 12/1994

ES⊕ **894.060**
026 198 012 AB
→8C-P-185 164
ES⊕ **630.190**
051 198 012 C
8C-P-185 165→
→8C-S-170 000
CS* **915.998**
037 198 011 E
→8C-P-220 000
CS* **446.920**
037 198 011 G
8C-P-220 001→

828.807
026 103 383 S
1,75 mm $\frac{\pm}{\pm}$ 83 Ø
→8C-S-170 000



137.285
050 103 383 B
1,60 mm $\frac{\pm}{\pm}$ 83 Ø
8C-S-170 001→



ZKS **819.817**
050 103 384 (10x)
M 11x1,5x96

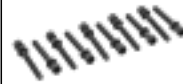

ZKHS **314.773**
026 198 025 A
centr. 8,5 mm
→8C-P-185 164



ZKHS **457.200**
026 198 025 C
centr. 6,5 mm
→8C-P-185 164





















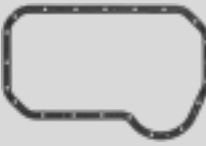

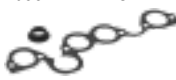





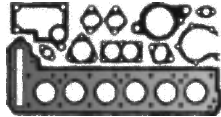
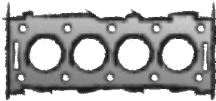

447.050
026 103 483 F
→8C-P-185 164

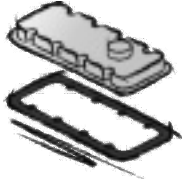
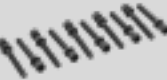
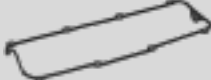

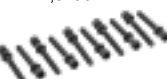

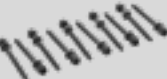
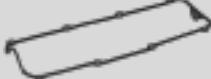

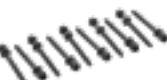













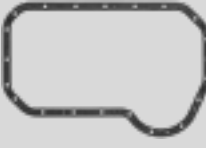



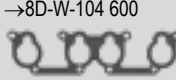





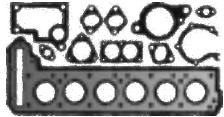
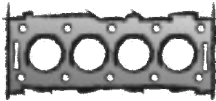

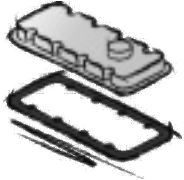
915.653
051 103 483 E
8C-P-185 165→

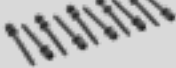
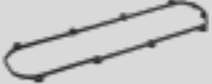

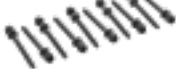

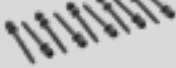
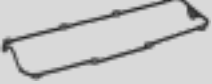



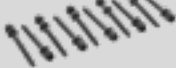
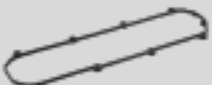











			<p>a) </p> <p>b) </p>	<p>K: </p> <p>N: </p>	
<p>VAS 702.706 FPM 553.190 026 109 675 FPM 8x</p>	<p>815.187 028 129 589 B 4x</p> 	<p>758.825 026 129 717 F</p> 	<p>a) 248.097 028 103 609 A</p>  <p>a) 495.620 044 103 609 D</p>  <p>b) 878.070 N 906 606 01 incl. 115.100 M 14x1,5x16</p> <p>b) 115.100 N 013 849.2 CU A 14x20x1,5</p>	<p>K:← 325.155 068 103 085 E ASW WD FPM/ACM 32x47x10</p> <p>K:→ 342.093 068 103 051 P ASW LD FPM 85x105x11</p> <p>K:→ 804.850 028 103 171 K SP LD PTFE/ACM 85</p> <p>K:→ 829.056 068 198 171 ASW LD FPM 85x105x11</p> <p>N:← 325.155 068 103 085 E ASW WD FPM/ACM 32x47x10</p>	
<p>VAS 702.706 FPM 553.190 026 109 675 FPM 8x</p>	<p>049.930 037 253 039 F</p> 	<p>AAS 195.670 026 129 717 D +035 121 171 C</p>  <p>460.745 035 121 171 C</p>  <p>757.756 026 129 717 D</p> 	<p>a) 248.097 028 103 609 A →8C-P-220 000</p>  <p>a) 495.620 044 103 609 D 8C-P-220 001→</p>  <p>b) 878.070 N 906 606 01 incl. 115.100 M 14x1,5x16</p> <p>b) 115.100 N 013 849.2 CU A 14x20x1,5</p>	<p>K:← 325.155 068 103 085 E ASW WD FPM/ACM 32x47x10</p> <p>K:→ 342.093 068 103 051 P ASW LD FPM 85x105x11</p> <p>K:→ 804.850 028 103 171 K SP LD PTFE/ACM 85</p> <p>K:→ 829.056 068 198 171 ASW LD FPM 85x105x11</p> <p>N:← 325.155 068 103 085 E ASW WD FPM/ACM 32x47x10</p>	

AUDI 				
ADA 4 Cyl. 1595 ccm Cyl. 81,0 Ø 80 06/1993 → 01/1996	CS* 446.920 037 198 011 G	828.807 026 103 383 S 1,75 mm $\frac{\pm}{\pm}$ 83 Ø →8C-S-170 000 137.285 050 103 383 B 1,60 mm $\frac{\pm}{\pm}$ 83 Ø 8C-S-170 001→	ZKS 819.817 050 103 384 (10x) M 11x1,5x96 	915.653 051 103 483 E 
ADP 4 Cyl. 1595 ccm Cyl. 81,0 Ø A4 11/1994 → 09/2001	ES⊕ 670.710 050 198 012 B CS* 670.700 050 198 011	629.363 050 103 383 1,65 mm $\frac{\pm}{\pm}$ 82,5 Ø 	ZKS 819.817 050 103 384 (10x) M 11x1,5x96 	915.653 051 103 483 E 
AHL 4 Cyl. 1595 ccm Cyl. 81,0 Ø A4 11/1994 → 09/2001	ES⊕ 698.430 8D-W-104 601→ CS* 339.610	475.920 06B 103 383 H 1,20 mm $\frac{\pm}{\pm}$ 82,5 Ø 2 ⊗ 	ZKS 804.870 06A 103 384 C (10x) M 10x1,5x120 	915.653 051 103 483 E 
AEH AKL 4 Cyl. 1595 ccm Cyl. 81,0 Ø A3 09/1996 → 05/2003	ES⊕ 530.590 06A 198 012 CS* 339.610	124.474 06B 103 383 AG 1,20 mm $\frac{\pm}{\pm}$ 82,5 Ø 2 ⊗ 	ZKS 804.870 06A 103 384 C (10x) M 10x1,5x120 	915.653 051 103 483 E 

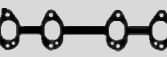
			<p>a) </p> <p>b) </p>	<p>K: </p> <p>N: </p>	
<p>VAS 702.706 FPM →Mot. ADA 034 669</p> <p>VAS 825.042 FPM Mot. ADA 034 670→</p> <p>553.190 026 109 675 FPM →Mot. ADA 034 669 8x</p> <p>701.289 027 109 675 FPM Mot. ADA 034 670→ 8x</p>	<p>049.930 037 253 039 F</p> 	<p>915.297 048 129 717 A</p> 	<p>a) 495.620 044 103 609 D</p>  <p>b) 878.070 N 906 606 01 incl. 115.100 M 14x1,5x16</p> <p>b) 115.100 N 013 849.2 CU A 14x20x1,5</p>	<p>K:← 325.155 068 103 085 E ASW WD FPM/ACM 32x47x10</p> <p>K:→ 342.093 068 103 051 P ASW LD FPM 85x105x11</p> <p>K:→ 804.850 028 103 171 K SP LD PTFE/ACM 85</p> <p>K:→ 829.056 068 198 171 ASW LD FPM 85x105x11</p> <p>N:← 325.155 068 103 085 E ASW WD FPM/ACM 32x47x10</p>	
<p>VAS 825.042 FPM</p> <p>701.289 027 109 675 FPM 8x</p>	<p>049.930 037 253 039 F</p> 	<p>165.210 037 129 717 C</p> 	<p>a) 495.620 044 103 609 D</p>  <p>b) 878.070 N 906 606 01 incl. 115.100 M 14x1,5x16</p> <p>b) 115.100 N 013 849.2 CU A 14x20x1,5</p>	<p>K:← 325.155 068 103 085 E ASW WD FPM/ACM 32x47x10</p> <p>K:→ 342.093 068 103 051 P ASW LD FPM 85x105x11</p> <p>K:→ 804.850 028 103 171 K SP LD PTFE/ACM 85</p> <p>K:→ 829.056 068 198 171 ASW LD FPM 85x105x11</p> <p>N:← 325.155 068 103 085 E ASW WD FPM/ACM 32x47x10</p>	
<p>VAS 825.042 FPM</p> <p>701.289 027 109 675 FPM 8x</p>	<p>049.930 037 253 039 F</p> 	<p>165.210 037 129 717 C →8D-W-104 600</p>  <p>497.740 06B 129 717 A 4x 8D-W-104 601→</p> 	<p>a) 030.793 Dirko HT</p> <p>b) 567.640 N 908 132 01 M 14x1,5x22</p>	<p>K:← 155.560 038 103 085 E ASW RD PTFE/ACM 35x48x10</p> <p>K:→ 012.380 06B 103 171 B IWD LD PTFE/ACM 85</p> <p>N:← 129.780 038 103 085 C ASW RD PTFE/ACM 32x47x10</p> <p>N:← 325.155 068 103 085 E ASW WD FPM/ACM 32x47x10</p>	
<p>VAS 825.042 FPM</p> <p>701.289 027 109 675 FPM 8x</p>	<p>625.760 037 253 039 D</p> 	<p>475.931 06A 133 398 F 4x</p> 	<p>a) 030.793 Dirko HT</p> <p>b) 567.640 N 908 132 01 M 14x1,5x22</p>	<p>K:← 155.560 038 103 085 E ASW RD PTFE/ACM 35x48x10</p> <p>K:→ 012.380 06B 103 171 B IWD LD PTFE/ACM 85</p> <p>N:← 129.780 038 103 085 C ASW RD PTFE/ACM 32x47x10</p> <p>N:← 325.155 068 103 085 E ASW WD FPM/ACM 32x47x10</p>	

AUDI 				
ALZ 4 Cyl. 1595 ccm Cyl. 81,0 Ø A4 07/2000 → 06/2008	ES⊕ 497.800 CS* 339.610	124.474 06B 103 383 AG 1,20 mm $\frac{2}{3}$ 82,5 Ø 2 ⊗ 	ZKS 804.870 06A 103 384 C (10x) M 10x1,5x120 	332.800 06B 103 483 L 
ANA ARM 4 Cyl. 1595 ccm Cyl. 81,0 Ø A4 11/1994 → 09/2001	ES⊕ 698.430 CS* 339.610	475.920 06B 103 383 H 1,20 mm $\frac{2}{3}$ 82,5 Ø 2 ⊗ 	ZKS 804.870 06A 103 384 C (10x) M 10x1,5x120 	915.653 051 103 483 E 
APF 4 Cyl. 1595 ccm Cyl. 81,0 Ø A3 09/1996 → 05/2003	ES⊕ 376.121 CS* 339.610	124.474 06B 103 383 AG 1,20 mm $\frac{2}{3}$ 82,5 Ø 2 ⊗ 	ZKS 804.870 06A 103 384 C (10x) M 10x1,5x120 	915.653 051 103 483 E 
AVU BFQ BGU BSE BSF CCSA CMXA 4 Cyl. 1595 ccm Cyl. 81,0 Ø A3 08/2000 → 03/2013	ES⊕ 376.131 CS* 339.610	124.474 06B 103 383 AG 1,20 mm $\frac{2}{3}$ 82,5 Ø 2 ⊗ 	ZKS 804.870 06A 103 384 C (10x) M 10x1,5x120 	332.800 06B 103 483 L 
BRY 4 Cyl. 1595 ccm Cyl. 81,0 Ø		688.250 ● 06A 103 383 AP 82,5 Ø 	ZKS 804.870 06A 103 384 C (10x) M 10x1,5x120 	332.800 06B 103 483 L 

AUDI

			<p>a) </p> <p>b) </p>	<p>K: </p> <p>N: </p>	
<p>724.590 036 109 675 A FPM 8x</p>	<p>049.930 037 253 039 F</p> 	<p>497.740 06B 129 717 A 4x</p> 	<p>a) 030.793 Dirko HT</p> <p>b) 567.640 N 908 132 01 M 14x1,5x22</p>	<p>K:← 155.560 038 103 085 E ASW RD PTFE/ACM 35x48x10</p> <p>K:→ 012.380 06B 103 171 B IWD LD PTFE/ACM 85</p> <p>N:← 129.780 038 103 085 C ASW RD PTFE/ACM 32x47x10</p>	
<p>VAS 825.042 FPM</p> <p>701.289 027 109 675 FPM 8x</p>	<p>049.930 037 253 039 F</p> 	<p>497.740 06B 129 717 A 4x</p> 	<p>a) 030.793 Dirko HT</p> <p>b) 567.640 N 908 132 01 M 14x1,5x22</p>	<p>K:← 155.560 038 103 085 E ASW RD PTFE/ACM 35x48x10</p> <p>K:→ 012.380 06B 103 171 B IWD LD PTFE/ACM 85</p> <p>N:← 129.780 038 103 085 C ASW RD PTFE/ACM 32x47x10</p> <p>N:← 325.155 068 103 085 E ASW WD FPM/ACM 32x47x10</p>	
<p>VAS 825.042 FPM</p> <p>701.289 027 109 675 FPM 8x</p>	<p>133.520 06A 253 039 L</p> 	<p>475.931 06A 133 398 F 4x</p> 	<p>a) 030.793 Dirko HT</p> <p>b) 567.640 N 908 132 01 M 14x1,5x22</p>	<p>K:← 155.560 038 103 085 E ASW RD PTFE/ACM 35x48x10</p> <p>K:← 475.961 054 115 147 B ASW RD FPM 35x48x10</p> <p>K:→ 012.380 06B 103 171 B IWD LD PTFE/ACM 85</p> <p>N:← 129.780 038 103 085 C ASW RD PTFE/ACM 32x47x10</p>	
<p>724.590 036 109 675 A FPM 8x</p>	<p>133.520 06A 253 039 L</p> 	<p>475.931 06A 133 398 F 4x</p> 	<p>a) 030.793 Dirko HT</p> <p>b) 567.640 N 908 132 01 M 14x1,5x22</p>	<p>K:← 155.560 038 103 085 E ASW RD PTFE/ACM 35x48x10</p> <p>K:→ 012.380 06B 103 171 B IWD LD PTFE/ACM 85</p> <p>N:← 129.780 038 103 085 C ASW RD PTFE/ACM 32x47x10</p>	
<p>724.590 036 109 675 A FPM 8x</p>	<p>625.760 037 253 039 D</p> 	<p>475.931 06A 133 398 F 4x</p> 	<p>a) 030.793 Dirko HT</p>	<p>K:← 155.560 038 103 085 E ASW RD PTFE/ACM 35x48x10</p> <p>K:→ 012.380 06B 103 171 B IWD LD PTFE/ACM 85</p> <p>N:← 129.780 038 103 085 C ASW RD PTFE/ACM 32x47x10</p>	

AUDI

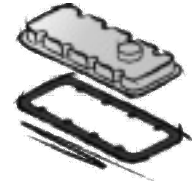
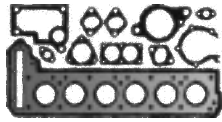

DT **DTA**
JU **PP**
SA

4 Cyl. **1595 ccm**
Cyl. 81,0 Ø

80
08/1978 → 09/1991

ES⊕ **515.311**
050 198 012 A
CS* **774.731**
037 198 011 C

828.807
026 103 383 S
1,75 mm $\frac{1}{16}$ 83 Ø



ZKS 819.817
050 103 384 (10x)
M 11x1,5x96



ZKHS 314.773
026 198 025 A
centr. 8,5 mm



ZKHS 457.200
026 198 025 C
centr. 6,5 mm



447.050
026 103 483 F

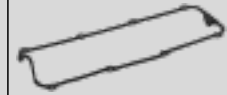

RN

4 Cyl. **1595 ccm**
Cyl. 81,0 Ø

80
09/1986 → 08/1991

ES⊕ **693.848**
026 198 012 T
CS* **774.731**
037 198 011 C

828.807
026 103 383 S
1,75 mm $\frac{1}{16}$ 83 Ø



ZKS 819.817
050 103 384 (10x)
M 11x1,5x96

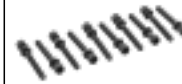

ZKHS 314.773
026 198 025 A
centr. 8,5 mm



ZKHS 457.200
026 198 025 C
centr. 6,5 mm



447.050
026 103 483 F



BAD

4 Cyl. **1598 ccm**
Cyl. 76,5 Ø

A2
05/2002 → 08/2005

ES⊕ **718.081**
CS* **891.780**







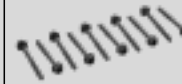















476.412
036 103 383 AB
0,64 mm $\frac{1}{16}$ 77,5 Ø











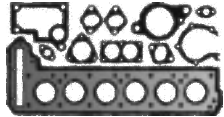
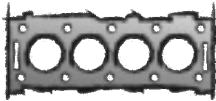

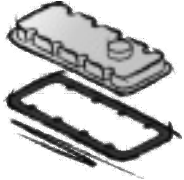
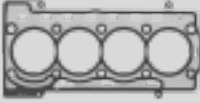

ZKS 057.220
036 103 384 E (10x)
M 9x1,25x97





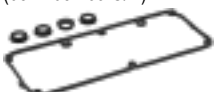
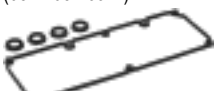
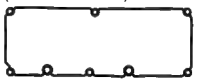









461.682
EL-Liq 74

			<p>a) </p> <p>b) </p>	<p>K: </p> <p>N: </p>	
<p>VAS 702.706 FPM 553.190 026 109 675 FPM 8x</p>	<p>815.187 028 129 589 B 4x</p> 	<p>AAS 195.670 026 129 717 D +035 121 171 C</p>  <p>460.745 035 121 171 C</p>  <p>757.756 026 129 717 D</p> 	<p>a) 248.097 028 103 609 A</p>  <p>a) 495.620 044 103 609 D</p>  <p>b) 878.070 N 906 606 01 incl. 115.100 M 14x1,5x16 b) 115.100 N 013 849.2 CU A 14x20x1,5</p>	<p>K:← 325.155 068 103 085 E ASW WD FPM/ACM 32x47x10 K:→ 342.093 068 103 051 P ASW LD FPM 85x105x11 K:→ 829.056 068 198 171 ASW LD FPM 85x105x11 N:← 325.155 068 103 085 E ASW WD FPM/ACM 32x47x10</p>	
<p>VAS 702.706 FPM 553.190 026 109 675 FPM 8x</p>	<p>815.187 028 129 589 B 4x</p> 	<p>AAS 195.670 026 129 717 D +035 121 171 C</p>  <p>460.745 035 121 171 C</p>  <p>757.756 026 129 717 D</p> 	<p>a) 248.097 028 103 609 A</p>  <p>a) 495.620 044 103 609 D</p>  <p>b) 878.070 N 906 606 01 incl. 115.100 M 14x1,5x16 b) 115.100 N 013 849.2 CU A 14x20x1,5</p>	<p>K:← 325.155 068 103 085 E ASW WD FPM/ACM 32x47x10 K:→ 342.093 068 103 051 P ASW LD FPM 85x105x11 K:→ 829.056 068 198 171 ASW LD FPM 85x105x11 N:← 325.155 068 103 085 E ASW WD FPM/ACM 32x47x10</p>	
<p>VAS 235.610 FPM 724.590 036 109 675 A FPM 16x</p>	<p>135.230 036 253 039 F</p> 	<p>151.140 03C 129 717 C</p> 	<p>a) 030.793 Dirko HT b) 567.640 N 908 132 01 M 14x1,5x22</p>	<p>K:← 158.060 036 103 085 H AW/BS RD FPM 32x42x6 K:→ 458.821 030 103 171 L IWD LD PTFE 85 N:← 076.110 036 103 085 A AW/BS RD FPM 27x42x8 N:← 364.710 036 103 085 F AW/BS RD FPM 35x46x7</p>	

<p>AUDI</p> 				
<p>BAG BLF</p> <p>4 Cyl. 1598 ccm Cyl. 76,5 Ø</p> <p>A3 08/2003 → 09/2007</p>	<p>ES⊕ 517.171 CS* 748.030 incl. 376.730 →8P-5B-000 000 →8P-4-103 000</p> <p>CS* 748.230 incl. 429.090 8P-4-103 001→ 8P-5B-000 001→</p>	<p>497.810 03C 103 383 D 77,5 Ø</p> 	<p>ZKS 803.740 036 103 384 B (10x) M 9x1,25x140</p> 	<p>461.682 EL-Liq 74</p>
<p>CAYB</p> <p>4 Cyl. 1598 ccm Cyl. 79,5 Ø</p> <p>A1 TDI 03/2011 → 04/2015</p> <p>A3 TDI 05/2009 → 03/2013</p>	<p>ES⊕ 236.170 (03L 103 469 C/R)</p>  <p>ES⊕ 589.830 (03L 103 469 H)</p>  <p>CS* 236.040 OKS 235.900 03L 198 070</p> 	<p>732.090 03L 103 383 BT 0,910 mm → 1,000 mm</p>  <p>1,55 mm $\frac{\pm}{\pm}$ 80,7 Ø 1 ⊗</p> <p>732.100 03L 103 383 CA 1,010 mm → 1,100 mm</p>  <p>1,63 mm $\frac{\pm}{\pm}$ 80,7 Ø 2 ⊗</p> <p>732.110 03L 103 383 CB 1,110 mm → 1,200 mm</p>  <p>1,71 mm $\frac{\pm}{\pm}$ 80,7 Ø 3 ⊗</p>	<p>ZKS 189.380 WHT 002 131 (10x) M 9x1,75x137</p> 	<p>ZKHS 380.440 (03L 103 469 C/R)</p>  <p>ZKHS 449.390 (03L 103 469 H)</p>  <p>722.100 03L 103 483 H (03L 103 469 H)</p>  <p>898.600 03L 103 483 C (03L 103 469 C/R)</p>  <p>461.682 EL-Liq 74 ↓ 380.150 04L 103 070 B (03L 103 469 C/R/S/T) 4x</p>  <p>722.080 03L 103 070 A (03L 103 469 H) 4x</p> <p>860.130 03L 103 487 2x</p> <p>722.090 03L 103 487 A 2x</p>

AUDI

			<p>a) </p> <p>b) </p>	<p>K: </p> <p>N: </p>	
<p>VAS 235.610 FPM 724.590 036 109 675 A FPM 16x</p>	<p>517.120 03C 253 039 A </p>	<p>151.140 03C 129 717 C </p>	<p>a) 030.793 Dirko HT b) 567.640 N 908 132 01 M 14x1,5x22</p>	<p>K:← 155.560 038 103 085 E ASW RD PTFE/ACM 35x48x10 K:→ 376.730 030 103 171 K IWD LD PTFE 85 →8P-4-103 000 →8P-5B-000 000 K:→ 429.090 030 103 171 S IWD LD PTFE 85 8P-4-103 001→ 8P-5B-000 001→</p>	
<p>VAS 235.610 FPM 724.590 036 109 675 A FPM 16x</p>	<p>007.870 03L 253 039 E </p>	<p>AAS 297.580 </p>	<p>a) 030.793 Dirko HT b) 567.640 N 908 132 01 M 14x1,5x22</p>	<p>K:← 155.560 038 103 085 E ASW RD PTFE/ACM 35x48x10 K:→ 364.700 03L 103 171 IWD LD PTFE/ACM 85 N:← 129.780 038 103 085 C ASW RD PTFE/ACM 32x47x10 →09/2009 N:← 897.690 03L 103 085 AW RD PTFE/ACM 32x47x10 10/2009→</p>	<p>TLS 244.441 </p>

AUDI

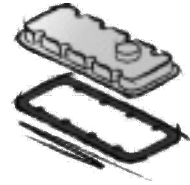
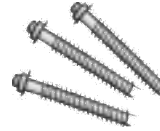

CAYC

4 Cyl. **1598 ccm**
Cyl. 79,5 Ø

A1 TDI

05/2010 → 04/2015

A3 TDI

05/2009 → 05/2013

ES⊕ **236.170**
(03L 103 469 C/R)



ES⊕ **589.830**
(03L 103 469 H)



CS* **236.040**
OKS **235.900**
03L 198 070



732.090

03L 103 383 BT

0,910 mm



→
1,000 mm

1,55 mm $\frac{1}{2}$ 80,7 Ø
1 ⊗

732.100

03L 103 383 CA

1,010 mm



→
1,100 mm

1,63 mm $\frac{1}{2}$ 80,7 Ø
2 ⊗

732.110

03L 103 383 CB

1,110 mm



→
1,200 mm

1,71 mm $\frac{1}{2}$ 80,7 Ø
3 ⊗

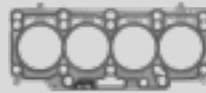
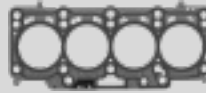
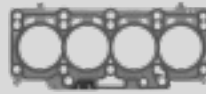

ZKS 189.380

WHT 002 131 (10x)
M 9x1,75x137



ZKHS 380.440

(03L 103 469 C/R)



ZKHS 449.390

(03L 103 469 H)



722.100

03L 103 483 H
(03L 103 469 H)

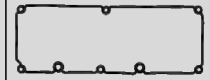

898.600

03L 103 483 C
(03L 103 469 C/R)

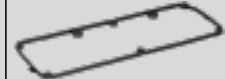

461.682

EL-Liq 74



380.150

04L 103 070 B
(03L 103 469 C/R/S/T)
4x



722.080











03L 103 070 A
(03L 103 469 H)
4x

860.130

03L 103 487
2x

722.090

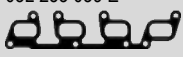
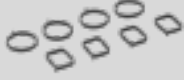
03L 103 487 A
2x

			<p>a) </p> <p>b) </p>	<p>K: </p> <p>N: </p>	
<p>VAS 235.610 FPM 724.590 036 109 675 A FPM 16x</p>	<p>007.870 03L 253 039 E </p>	<p>AAS 297.580 </p>	<p>a) 030.793 Dirko HT b) 567.640 N 908 132 01 M 14x1,5x22</p>	<p>K:← 155.560 038 103 085 E ASW RD PTFE/ACM 35x48x10 K:→ 364.700 03L 103 171 IWD LD PTFE/ACM 85 N:← 129.780 038 103 085 C ASW RD PTFE/ACM 32x47x10 →09/2009 N:← 897.690 03L 103 085 AW RD PTFE/ACM 32x47x10 10/2009→</p>	<p>TLS 232.830 </p> <p>TLS 244.441 </p>

AUDI

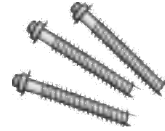
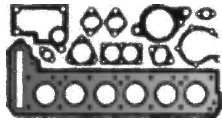

CLHA CRKB
CXXB DBKA
DDYB

4 Cyl. **1598 ccm**
Cyl. 79,5 Ø

A3 TDI
10/2012 →

ES⊕ **576.280**

CS* **452.990**
OKS **482.140**
03N 198 070



718.051
04L 103 383 C
 0,910 mm
→
1,000 mm
1,55 mm $\frac{3}{4}$ 80,5 Ø
1 ⊗

718.061
04L 103 383 D
 1,010 mm
→
1,100 mm
1,63 mm $\frac{3}{4}$ 80,5 Ø
2 ⊗

718.071
04L 103 383 E
 1,110 mm
→
1,200 mm
1,71 mm $\frac{3}{4}$ 80,5 Ø
3 ⊗

ZKS 351.900
WHT 005 673 (10x)
M12x1,75x206



ZKHS 982.100
(04L 103 469 A/P/S)
ZKHS 982.110
(03L 103 469 S/T)

330.200
03L 103 483 S
(03L 103 469 S/T)

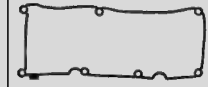

374.000
04L 103 483
(04L 103 469 A/P/S)



461.682
EL-Liq 74
↓
380.150
04L 103 070 B
(03L 103 469 C/R/S/T)
4x



811.540
04L 103 070 A
(04L 103 469 A/P/S)
4x

CXMA
4 Cyl. **1598 ccm**
Cyl. 79,5 Ø

A1 TDI
11/2014 → 10/2018

ES⊕ **496.060**

CS* **452.990**
OKS **482.140**
03N 198 070



718.051
04L 103 383 C
 0,910 mm
→
1,000 mm
1,55 mm $\frac{3}{4}$ 80,5 Ø
1 ⊗

718.061
04L 103 383 D
 1,010 mm
→
1,100 mm
1,63 mm $\frac{3}{4}$ 80,5 Ø
2 ⊗

718.071
04L 103 383 E
 1,110 mm
→
1,200 mm
1,71 mm $\frac{3}{4}$ 80,5 Ø
3 ⊗

ZKS 351.900
WHT 005 673 (10x)
M12x1,75x206



ZKHS 982.100
(04L 103 469 A/P/S)
ZKHS 982.110
(03L 103 469 S/T)

330.200
03L 103 483 S
(03L 103 469 S/T)

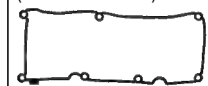



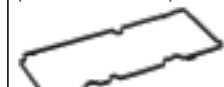











374.000
04L 103 483
(04L 103 469 A/P/S)



461.682
EL-Liq 74
↓
380.150
04L 103 070 B
(03L 103 469 C/R/S/T)
4x



811.540
04L 103 070 A
(04L 103 469 A/P/S)
4x

			<p>a) </p> <p>b) </p>	<p>K: </p> <p>N: </p>	
<p>VAS 235.610 FPM 724.590 036 109 675 A FPM 16x</p>	<p>729.571 04L 253 039 B</p> 	<p>352.810 04L 129 717 D</p> 	<p>a) 030.793 Dirko HT</p> <p>b) 567.640 N 908 132 01 M 14x1,5x22</p>	<p>K:← 340.290 04L 103 151 SP RD PTFE 35</p> <p>K:→ 340.280 04L 103 171 IWD LD PTFE 85</p> <p>N:← 897.690 03L 103 085 AW RD PTFE/ACM 32x47x10</p>	<p>TLS 570.870</p> 
<p>VAS 235.610 FPM 724.590 036 109 675 A FPM 16x</p>	<p>729.571 04L 253 039 B</p> 	<p>352.810 04L 129 717 D</p> 	<p>a) 030.793 Dirko HT</p> <p>b) 567.640 N 908 132 01 M 14x1,5x22</p>	<p>K:← 340.290 04L 103 151 SP RD PTFE 35</p> <p>K:→ 340.280 04L 103 171 IWD LD PTFE 85</p> <p>N:← 897.690 03L 103 085 AW RD PTFE/ACM 32x47x10</p>	<p>TLS 570.870</p> 

AUDI

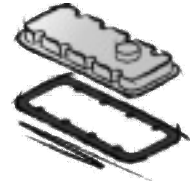
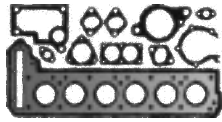

**DDYA
DGTE**

4 Cyl. **1598 ccm**
Cyl. 79,5 Ø

A3 TDI
02/2017 → 10/2020

Q2 TDI
06/2016 →

ES⊕ **496.070**

Delphi



ES⊕ **576.280**



CS* **452.990**

OKS **482.140**

03N 198 070



718.051

04L 103 383 C

0,910 mm

→
1,000 mm

1,55 mm $\frac{+}{-}$ 80,5 Ø
1 ⊗

718.061

04L 103 383 D

1,010 mm

→
1,100 mm

1,63 mm $\frac{+}{-}$ 80,5 Ø
2 ⊗

718.071

04L 103 383 E

1,110 mm

→
1,200 mm

1,71 mm $\frac{+}{-}$ 80,5 Ø
3 ⊗

ZKS **351.900**

WHT 005 673 (10x)
M12x1,75x206



ZKHS **982.100**

(04L 103 469 A/P/S)

ZKHS **982.110**
(03L 103 469 S/T)

330.200

03L 103 483 S
(03L 103 469 S/T)

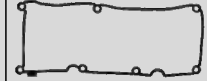

374.000

04L 103 483
(04L 103 469 A/P/S)



461.682

EL-Liq 74

↓

380.150

04L 103 070 B
(03L 103 469 C/R/S/T)
4x



811.540

04L 103 070 A
(04L 103 469 A/P/S)
4x

ADR

4 Cyl. **1781 ccm**
Cyl. 81,0 Ø

A4
11/1994 → 09/2001

A6
12/1995 → 12/1997

Cabrio
01/1997 → 08/2000

ES⊕ **183.890** ●

058 198 012



ES⊕ **264.730**

058 198 012
+058 198 025 A

CS* **670.730**

058 198 011

SZ **863.590**

058 198 217



366.670

058 103 383 Q

1,22 mm $\frac{+}{-}$ 82,5 Ø



ZKS **104.930**

058 103 385 A (10x)
M 11x1,5x96



ZKHS **633.350**

058 198 025 A



476.020















058 103 483 F

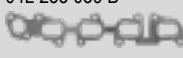
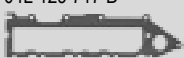

476.030

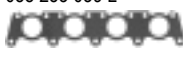
058 103 484 C

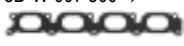

			<p>a) </p> <p>b) </p>	<p>K: </p> <p>N: </p>	
<p>VAS 235.610 FPM 724.590 036 109 675 A FPM 16x</p>	<p>729.571 04L 253 039 B </p>	<p>352.810 04L 129 717 D </p>	<p>a) 030.793 Dirko HT</p> <p>b) 567.640 N 908 132 01 M 14x1,5x22</p>	<p>K:← 340.290 04L 103 151 SP RD PTFE 35</p> <p>K:→ 340.280 04L 103 171 IWD LD PTFE 85</p> <p>N:← 897.690 03L 103 085 AW RD PTFE/ACM 32x47x10</p>	<p>TLS 570.870 </p>
<p>VAS 235.620 FPM 724.590 036 109 675 A FPM 20x</p>	<p>148.190 058 253 039 L </p>	<p>497.230 058 129 717 C Cabrio B3 A6 4A2/4A5 4x </p> <p>630.970 058 129 717 B A4 8D2/8D5 →8D-W-007 799 </p> <p>476.460 058 129 717 D A4 8D2/8D5 8D-W-007 800→ </p>	<p>a) 163.520 058 103 609 E →Mot. ADR 500 000 </p> <p>a) 030.793 Dirko HT Mot. ADR 500 001→</p> <p>b) 589.680 059 103 193 M 26x1,5x16 →Mot. ADR 500 000</p> <p>b) 878.080 incl. 133.051 059 103 193 M 26x1,5x16 →Mot. ADR 500 000</p> <p>b) 567.640 N 908 132 01 M 14x1,5x22 Mot. ADR 500 001→</p> <p>b) 133.051 N 043 854.1 CU A 26x31x2 →Mot. ADR 500 000</p>	<p>K:← 129.780 038 103 085 C ASW RD PTFE/ACM 32x47x10</p> <p>K:← 325.155 068 103 085 E ASW WD FPM/ACM 32x47x10</p> <p>K:→ 342.093 068 103 051 P ASW LD FPM 85x105x11</p> <p>K:→ 804.850 028 103 171 K SP LD PTFE/ACM 85</p> <p>K:→ 829.056 068 198 171 ASW LD FPM 85x105x11</p> <p>N:← 129.780 038 103 085 C ASW RD PTFE/ACM 32x47x10 2x</p> <p>N:← 325.155 068 103 085 E ASW WD FPM/ACM 32x47x10 2x</p>	

AUDI

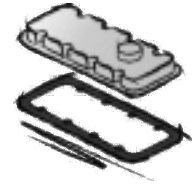

AEB
4 Cyl. **1781 ccm**
Cyl. 81,0 Ø

A4
01/1995 → 09/2001
A6
01/1997 → 01/2005

ES⊕ **183.890 ●**
058 198 012



ES⊕ **264.730**
058 198 012
+058 198 025 A
CS* **670.730**
058 198 011
SZ **863.590**
058 198 217



366.670
058 103 383 Q
1,22 mm $\frac{3}{4}$ 82,5 Ø



ZKS 104.930
058 103 385 A (10x)
M 11x1,5x96



ZKHS 633.350
058 198 025 A



476.020
058 103 483 F

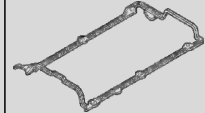

476.030
058 103 484 C



AFY
4 Cyl. **1781 ccm**
Cyl. 81,0 Ø

A4
04/1995 → 09/2001
A6
05/1997 → 01/2005

ES⊕ **183.890 ●**
058 198 012



ES⊕ **264.730**
058 198 012
+058 198 025 A
CS* **670.730**
058 198 011
SZ **863.590**
058 198 217



366.670
058 103 383 Q
1,22 mm $\frac{3}{4}$ 82,5 Ø

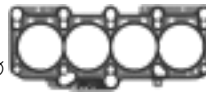

ZKS 104.930
058 103 385 A (10x)
M 11x1,5x96



ZKHS 633.350
058 198 025 A

















476.020
058 103 483 F



476.030
058 103 484 C



			<p>a) </p> <p>b) </p>	<p>K: </p> <p>N: </p>	
<p>VAS 235.620 FPM 724.590 036 109 675 A FPM 20x</p>	<p>148.190 058 253 039 L</p> 	<p>630.970 058 129 717 B</p> 	<p>a) 163.520 058 103 609 E</p>  <p>b) 589.680 059 103 193 M 26x1,5x16</p> <p>b) 878.080 incl. 133.051 059 103 193 M 26x1,5x16</p> <p>b) 133.051 N 043 854.1 CU A 26x31x2</p>	<p>K:← 129.780 038 103 085 C ASW RD PTFE/ACM 32x47x10</p> <p>K:← 325.155 068 103 085 E ASW WD FPM/ACM 32x47x10</p> <p>K:→ 342.093 068 103 051 P ASW LD FPM 85x105x11</p> <p>K:→ 804.850 028 103 171 K SP LD PTFE/ACM 85</p> <p>K:→ 829.056 068 198 171 ASW LD FPM 85x105x11</p> <p>N:← 129.780 038 103 085 C ASW RD PTFE/ACM 32x47x10 2x</p> <p>N:← 325.155 068 103 085 E ASW WD FPM/ACM 32x47x10 2x</p>	<p>TLS 703.960</p> 
<p>VAS 235.620 FPM 724.590 036 109 675 A FPM 20x</p>	<p>148.190 058 253 039 L</p> 	<p>630.970 058 129 717 B</p> 	<p>a) 163.520 058 103 609 E →Mot. AFY 005 000</p>  <p>a) 030.793 Dirko HT Mot. AFY 005 001→</p> <p>b) 589.680 059 103 193 M 26x1,5x16 →Mot. AFY 005 000</p> <p>b) 878.080 incl. 133.051 059 103 193 M 26x1,5x16 →Mot. AFY 005 000</p> <p>b) 567.640 N 908 132 01 M 14x1,5x22 Mot. AFY 005 001→</p> <p>b) 133.051 N 043 854.1 CU A 26x31x2 →Mot. AFY 005 000</p>	<p>K:← 129.780 038 103 085 C ASW RD PTFE/ACM 32x47x10</p> <p>K:← 325.155 068 103 085 E ASW WD FPM/ACM 32x47x10</p> <p>K:→ 342.093 068 103 051 P ASW LD FPM 85x105x11</p> <p>K:→ 804.850 028 103 171 K SP LD PTFE/ACM 85</p> <p>K:→ 829.056 068 198 171 ASW LD FPM 85x105x11</p> <p>N:← 129.780 038 103 085 C ASW RD PTFE/ACM 32x47x10 2x</p> <p>N:← 325.155 068 103 085 E ASW WD FPM/ACM 32x47x10 2x</p>	

AUDI

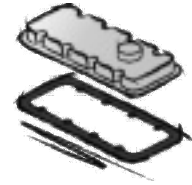
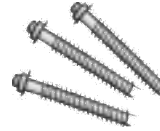

AGN
4 Cyl. **1781 ccm**
Cyl. 81,0 Ø
A3
09/1996 → 05/2003

ES⊕ **530.610**
06A 198 012 A
→8L-V-200 000
ES⊕ **736.880**
8L-W-000 001→
CS* **292.011**
SZ **863.590**
058 198 217



366.670
058 103 383 Q
1,22 mm $\frac{3}{4}$ 82,5 Ø



ZKS 130.830
06A 103 385 A (10x)
M 10x1,5x115



ZKHS 633.350
058 198 025 A



476.020
058 103 483 F



476.030
058 103 484 C



AGU
4 Cyl. **1781 ccm**
Cyl. 81,0 Ø
A3
12/1996 → 05/2003

ES⊕ **530.610**
06A 198 012 A
CS* **292.011**
SZ **863.590**
058 198 217



366.670
058 103 383 Q
1,22 mm $\frac{3}{4}$ 82,5 Ø



ZKS 130.830
06A 103 385 A (10x)
M 10x1,5x115



ZKHS 633.350
058 198 025 A



476.020
058 103 483 F



476.030
058 103 484 C



AJL
4 Cyl. **1781 ccm**
Cyl. 81,0 Ø
A4
12/1997 → 09/2001
A6
12/1997 → 01/2005

ES⊕ **183.890** ●
058 198 012
ES⊕ **264.730**
058 198 012
+058 198 025 A
SZ **863.590**
058 198 217



366.670
058 103 383 Q
1,22 mm $\frac{3}{4}$ 82,5 Ø



ZKS 104.930
058 103 385 A (10x)
M 11x1,5x96



ZKHS 633.350
058 198 025 A



















476.020
058 103 483 F



476.030
058 103 484 C



			<p>a) </p> <p>b) </p>	<p>K: </p> <p>N: </p>	
<p>VAS 235.620 FPM 724.590 036 109 675 A FPM 20x</p>	<p>148.190 058 253 039 L </p>	<p>630.970 058 129 717 B →8L-V-200 000  736.180 06A 133 398 D 4x 8L-W-000 001→ </p>	<p>a) 030.793 Dirko HT b) 567.640 N 908 132 01 M 14x1,5x22</p>	<p>K:← 155.560 038 103 085 E ASW RD PTFE/ACM 35x48x10 K:← 475.961 054 115 147 B ASW RD FPM 35x48x10 K:→ 012.370 06A 103 171 A IWD LD PTFE/ACM 85 N:← 129.780 038 103 085 C ASW RD PTFE/ACM 32x47x10 2x N:← 325.155 068 103 085 E ASW WD FPM/ACM 32x47x10 2x</p>	
<p>VAS 235.620 FPM 724.590 036 109 675 A FPM 20x</p>	<p>148.190 058 253 039 L </p>	<p>630.970 058 129 717 B </p>	<p>a) 030.793 Dirko HT b) 567.640 N 908 132 01 M 14x1,5x22</p>	<p>K:← 155.560 038 103 085 E ASW RD PTFE/ACM 35x48x10 K:← 475.961 054 115 147 B ASW RD FPM 35x48x10 K:→ 012.370 06A 103 171 A IWD LD PTFE/ACM 85 N:← 129.780 038 103 085 C ASW RD PTFE/ACM 32x47x10 2x N:← 325.155 068 103 085 E ASW WD FPM/ACM 32x47x10 2x</p>	<p>TLS 717.951 </p>
<p>VAS 235.620 FPM 724.590 036 109 675 A FPM 20x</p>	<p>148.190 058 253 039 L </p>	<p>630.970 058 129 717 B </p>	<p>a) 030.793 Dirko HT b) 567.640 N 908 132 01 M 14x1,5x22</p>	<p>K:← 129.780 038 103 085 C ASW RD PTFE/ACM 32x47x10 K:← 325.155 068 103 085 E ASW WD FPM/ACM 32x47x10 K:→ 804.850 028 103 171 K SP LD PTFE/ACM 85 N:← 129.780 038 103 085 C ASW RD PTFE/ACM 32x47x10 2x N:← 325.155 068 103 085 E ASW WD FPM/ACM 32x47x10 2x</p>	<p>TLS 703.960 </p>

AUDI

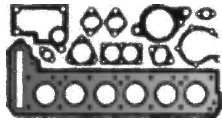

AMB
4 Cyl. **1781 ccm**
Cyl. 81,0 Ø
A4
05/2000 → 12/2005

ES⊕ **461.380**
→8E-3-500 000
ES⊕ **729.861**
8E-4-000 001→
CS **530.580**
06A 198 011 A
SZ **863.590**
058 198 217



366.670
058 103 383 Q
1,22 mm $\frac{3}{4}$ 82,5 Ø



ZKS **130.830**
06A 103 385 A (10x)
M 10x1,5x115



ZKHS **633.350**
058 198 025 A



476.020
058 103 483 F



476.030
058 103 484 C

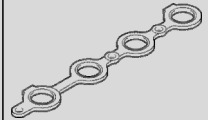

ANB
4 Cyl. **1781 ccm**
Cyl. 81,0 Ø
A4
01/1995 → 09/2001
A6
01/1997 → 01/2005

ES⊕ **183.890** ●
058 198 012
ES⊕ **264.730**
058 198 012
+058 198 025 A
CS* **670.730**
058 198 011
SZ **863.590**
058 198 217



366.670
058 103 383 Q
1,22 mm $\frac{3}{4}$ 82,5 Ø

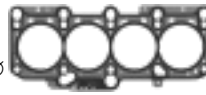

ZKS **104.930**
058 103 385 A (10x)
M 11x1,5x96



ZKHS **633.350**
058 198 025 A



476.020
058 103 483 F

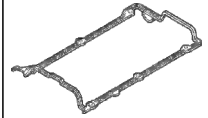

476.030
058 103 484 C



APG
4 Cyl. **1781 ccm**
Cyl. 81,0 Ø
A3
09/1996 → 05/2003

ES⊕ **736.880**
CS* **292.011**
SZ **863.590**
058 198 217



366.670
058 103 383 Q
1,22 mm $\frac{3}{4}$ 82,5 Ø



ZKS **130.830**
06A 103 385 A (10x)
M 10x1,5x115



ZKHS **633.350**
058 198 025 A





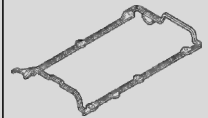



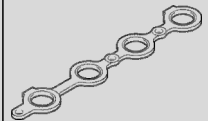









476.020
058 103 483 F



476.030
058 103 484 C



			<p>a) </p> <p>b) </p>	<p>K: </p> <p>N: </p>	
<p>VAS 235.620 FPM 724.590 036 109 675 A FPM 20x</p>	<p>148.190 058 253 039 L </p>	<p>476.460 058 129 717 D →8E-3-500 000  080.990 06B 129 717 F 8E-4-000 001→ </p>	<p>a) 030.793 Dirko HT b) 567.640 N 908 132 01 M 14x1,5x22</p>	<p>K:← 155.560 038 103 085 E ASW RD PTFE/ACM 35x48x10 K:→ 012.370 06A 103 171 A IWD LD PTFE/ACM 85 N:← 129.780 038 103 085 C ASW RD PTFE/ACM 32x47x10 2x</p>	<p>TLS 703.960 </p>
<p>VAS 235.620 FPM 724.590 036 109 675 A FPM 20x</p>	<p>148.190 058 253 039 L </p>	<p>476.460 058 129 717 D </p>	<p>a) 030.793 Dirko HT b) 567.640 N 908 132 01 M 14x1,5x22</p>	<p>K:← 129.780 038 103 085 C ASW RD PTFE/ACM 32x47x10 K:← 325.155 068 103 085 E ASW WD FPM/ACM 32x47x10 K:→ 804.850 028 103 171 K SP LD PTFE/ACM 85 N:← 129.780 038 103 085 C ASW RD PTFE/ACM 32x47x10 2x N:← 325.155 068 103 085 E ASW WD FPM/ACM 32x47x10 2x</p>	<p>TLS 703.960 </p>
<p>VAS 235.620 FPM 724.590 036 109 675 A FPM 20x</p>	<p>148.190 058 253 039 L </p>	<p>736.180 06A 133 398 D 4x </p>	<p>a) 030.793 Dirko HT b) 567.640 N 908 132 01 M 14x1,5x22</p>	<p>K:← 155.560 038 103 085 E ASW RD PTFE/ACM 35x48x10 K:← 475.961 054 115 147 B ASW RD FPM 35x48x10 K:→ 012.370 06A 103 171 A IWD LD PTFE/ACM 85 N:← 129.780 038 103 085 C ASW RD PTFE/ACM 32x47x10 2x N:← 325.155 068 103 085 E ASW WD FPM/ACM 32x47x10 2x</p>	

AUDI

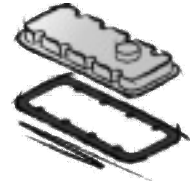
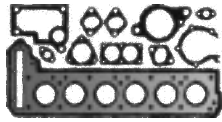

APT
4 Cyl. **1781 ccm**
Cyl. 81,0 Ø

A4
11/1994 → 09/2001

ES⊕ **183.890 ●**
058 198 012



ES⊕ **264.730**
058 198 012
+058 198 025 A

CS* **670.730**
058 198 011

SZ **863.590**
058 198 217



366.670
058 103 383 Q
1,22 mm $\frac{1}{2}$ 82,5 Ø



ZKS 104.930
058 103 385 A (10x)
M 11x1,5x96



ZKHS 633.350
058 198 025 A



476.020
058 103 483 F

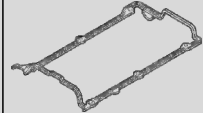

476.030
058 103 484 C



**APU
ARK**
4 Cyl. **1781 ccm**
Cyl. 81,0 Ø

A4
01/1995 → 09/2001

A6
01/1997 → 01/2005

ES⊕ **183.890 ●**
058 198 012



ES⊕ **264.730**
058 198 012
+058 198 025 A

CS* **670.730**
058 198 011

SZ **863.590**
058 198 217



366.670
058 103 383 Q
1,22 mm $\frac{1}{2}$ 82,5 Ø

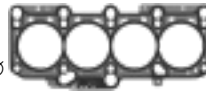

ZKS 104.930
058 103 385 A (10x)
M 11x1,5x96



ZKHS 633.350
058 198 025 A

















476.020
058 103 483 F



476.030
058 103 484 C



			<p>a) </p> <p>b) </p>	<p>K: </p> <p>N: </p>	
<p>VAS 235.620 FPM 724.590 036 109 675 A FPM 20x</p>	<p>148.190 058 253 039 L </p>	<p>476.460 058 129 717 D </p>	<p>a) 163.520 058 103 609 E →Mot. APT 020 000 </p> <p>a) 030.793 Dirko HT Mot. APT 020 001→</p> <p>b) 589.680 059 103 193 M 26x1,5x16 →Mot. APT 020 000</p> <p>b) 878.080 incl. 133.051 059 103 193 M 26x1,5x16 →Mot. APT 020 000</p> <p>b) 567.640 N 908 132 01 M 14x1,5x22 Mot. APT 020 001→</p> <p>b) 133.051 N 043 854.1 CU A 26x31x2 →Mot. APT 020 000</p>	<p>K:← 129.780 038 103 085 C ASW RD PTFE/ACM 32x47x10</p> <p>K:← 325.155 068 103 085 E ASW WD FPM/ACM 32x47x10</p> <p>K:→ 804.850 028 103 171 K SP LD PTFE/ACM 85</p> <p>N:← 129.780 038 103 085 C ASW RD PTFE/ACM 32x47x10 2x</p> <p>N:← 325.155 068 103 085 E ASW WD FPM/ACM 32x47x10 2x</p>	
<p>VAS 235.620 FPM 724.590 036 109 675 A FPM 20x</p>	<p>148.190 058 253 039 L </p>	<p>476.460 058 129 717 D </p>	<p>a) 030.793 Dirko HT</p> <p>b) 567.640 N 908 132 01 M 14x1,5x22</p>	<p>K:← 129.780 038 103 085 C ASW RD PTFE/ACM 32x47x10</p> <p>K:→ 804.850 028 103 171 K SP LD PTFE/ACM 85</p> <p>N:← 129.780 038 103 085 C ASW RD PTFE/ACM 32x47x10 2x</p>	<p>TLS 703.960 </p>

AUDI

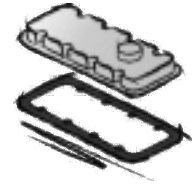

ARG
4 Cyl. **1781 ccm**
Cyl. 81,0 Ø

A4
11/1994 → 09/2001

ES⊕ **183.890 ●**
058 198 012



ES⊕ **264.730**
058 198 012
+058 198 025 A

CS* **670.730**
058 198 011

SZ **863.590**
058 198 217



366.670
058 103 383 Q
1,22 mm $\frac{1}{2}$ 82,5 Ø



ZKS 104.930
058 103 385 A (10x)
M 11x1,5x96



ZKHS 633.350
058 198 025 A



476.020
058 103 483 F

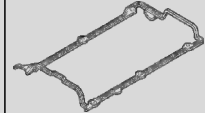

476.030
058 103 484 C



AJQ **AMU**
APP **AQA**
ARX **ARY**
ARZ **ATC**
AUM **AUC**
AWP

4 Cyl. **1781 ccm**
Cyl. 81,0 Ø

A3
12/1996 → 05/2003

TT
10/1998 → 06/2006

ES⊕ **461.380**
CS* **292.011**
SZ **863.590**
058 198 217



366.670
058 103 383 Q
1,22 mm $\frac{1}{2}$ 82,5 Ø

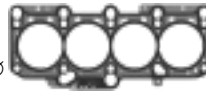

ZKS 130.830
06A 103 385 A (10x)
M 10x1,5x115



ZKHS 633.350
058 198 025 A

















476.020
058 103 483 F



476.030
058 103 484 C



			<p>a) </p> <p>b) </p>	<p>K: </p> <p>N: </p>	
<p>VAS 235.620 FPM 724.590 036 109 675 A FPM 20x</p>	<p>148.190 058 253 039 L </p>	<p>476.460 058 129 717 D </p>	<p>a) 163.520 058 103 609 E →Mot. ARG 020 000 </p> <p>a) 030.793 Dirko HT Mot. ARG 020 001→</p> <p>b) 589.680 059 103 193 M 26x1,5x16 →Mot. ARG 020 000</p> <p>b) 878.080 incl. 133.051 059 103 193 M 26x1,5x16 →Mot. ARG 020 000</p> <p>b) 567.640 N 908 132 01 M 14x1,5x22 Mot. ARG 020 001→</p> <p>b) 133.051 N 043 854.1 CU A 26x31x2 →Mot. ARG 020 000</p>	<p>K:← 129.780 038 103 085 C ASW RD PTFE/ACM 32x47x10</p> <p>K:← 325.155 068 103 085 E ASW WD FPM/ACM 32x47x10</p> <p>K:→ 804.850 028 103 171 K SP LD PTFE/ACM 85</p> <p>N:← 129.780 038 103 085 C ASW RD PTFE/ACM 32x47x10 2x</p> <p>N:← 325.155 068 103 085 E ASW WD FPM/ACM 32x47x10 2x</p>	
<p>VAS 235.620 FPM 724.590 036 109 675 A FPM 20x</p>	<p>148.190 058 253 039 L </p>	<p>476.460 058 129 717 D </p>	<p>a) 030.793 Dirko HT</p> <p>b) 567.640 N 908 132 01 M 14x1,5x22</p>	<p>K:← 155.560 038 103 085 E ASW RD PTFE/ACM 35x48x10</p> <p>K:← 475.961 054 115 147 B ASW RD FPM 35x48x10</p> <p>K:→ 012.370 06A 103 171 A IWD LD PTFE/ACM 85</p> <p>N:← 129.780 038 103 085 C ASW RD PTFE/ACM 32x47x10 2x</p> <p>N:← 325.155 068 103 085 E ASW WD FPM/ACM 32x47x10 2x</p>	<p>TLS 717.951 </p>

AUDI

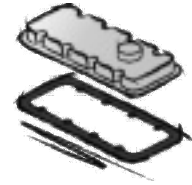
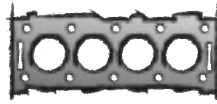

ATW
4 Cyl. **1781 ccm**
Cyl. 81,0 Ø

A4
01/1995 → 09/2001

ES⊕ **461.380**
CS* **670.730**
058 198 011
SZ **863.590**
058 198 217



366.670
058 103 383 Q
1,22 mm $\frac{1}{2}$ 82,5 Ø



ZKS 104.930
058 103 385 A (10x)
M 11x1,5x96



ZKHS 633.350
058 198 025 A



476.020
058 103 483 F

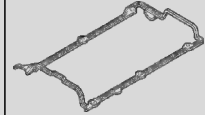

476.030
058 103 484 C



AMK APX
APY AUL
BAM

4 Cyl. **1781 ccm**
Cyl. 81,0 Ø

A3 S3
03/1999 → 05/2003

TT
10/1998 → 06/2006

ES⊕ **461.380**
CS* **292.011**
SZ **863.590**
058 198 217



366.670
058 103 383 Q
1,22 mm $\frac{1}{2}$ 82,5 Ø



ZKS 130.830
06A 103 385 A (10x)
M 10x1,5x115



ZKHS 633.350
058 198 025 A



476.020
058 103 483 F



476.030
058 103 484 C



AVJ

4 Cyl. **1781 ccm**
Cyl. 81,0 Ø

A4
11/2000 → 07/2002

ES⊕ **461.380**
CS **530.580**
06A 198 011 A
SZ **863.590**
058 198 217



366.670
058 103 383 Q
1,22 mm $\frac{1}{2}$ 82,5 Ø



ZKS 130.830
06A 103 385 A (10x)
M 10x1,5x115



ZKHS 633.350
058 198 025 A





















476.020
058 103 483 F



476.030
058 103 484 C



			<p>a) </p> <p>b) </p>	<p>K: </p> <p>N: </p>	
<p>VAS 235.620 FPM 724.590 036 109 675 A FPM 20x</p>	<p>148.190 058 253 039 L </p>	<p>476.460 058 129 717 D </p>	<p>a) 163.520 058 103 609 E </p> <p>b) 589.680 059 103 193 M 26x1,5x16</p> <p>b) 878.080 incl. 133.051 059 103 193 M 26x1,5x16</p> <p>b) 133.051 N 043 854.1 CU A 26x31x2</p>	<p>K:← 129.780 038 103 085 C ASW RD PTFE/ACM 32x47x10</p> <p>K:← 325.155 068 103 085 E ASW WD FPM/ACM 32x47x10</p> <p>K:→ 342.093 068 103 051 P ASW LD FPM 85x105x11</p> <p>K:→ 804.850 028 103 171 K SP LD PTFE/ACM 85</p> <p>K:→ 829.056 068 198 171 ASW LD FPM 85x105x11</p> <p>N:← 129.780 038 103 085 C ASW RD PTFE/ACM 32x47x10 2x</p> <p>N:← 325.155 068 103 085 E ASW WD FPM/ACM 32x47x10 2x</p>	<p>TLS 703.960 </p>
<p>VAS 235.620 FPM 724.590 036 109 675 A FPM 20x</p>	<p>148.190 058 253 039 L </p>	<p>476.460 058 129 717 D </p>	<p>a) 030.793 Dirko HT</p> <p>b) 567.640 N 908 132 01 M 14x1,5x22</p>	<p>K:← 155.560 038 103 085 E ASW RD PTFE/ACM 35x48x10</p> <p>K:← 475.961 054 115 147 B ASW RD FPM 35x48x10</p> <p>K:→ 012.370 06A 103 171 A IWD LD PTFE/ACM 85</p> <p>N:← 129.780 038 103 085 C ASW RD PTFE/ACM 32x47x10 2x</p> <p>N:← 325.155 068 103 085 E ASW WD FPM/ACM 32x47x10 2x</p>	<p>TLS 703.960 </p>
<p>VAS 235.620 FPM 724.590 036 109 675 A FPM 20x</p>	<p>148.190 058 253 039 L </p>	<p>476.460 058 129 717 D </p>	<p>a) 030.793 Dirko HT</p> <p>b) 567.640 N 908 132 01 M 14x1,5x22</p>	<p>K:← 155.560 038 103 085 E ASW RD PTFE/ACM 35x48x10</p> <p>K:← 475.961 054 115 147 B ASW RD FPM 35x48x10</p> <p>K:→ 012.370 06A 103 171 A IWD LD PTFE/ACM 85</p> <p>N:← 129.780 038 103 085 C ASW RD PTFE/ACM 32x47x10 2x</p> <p>N:← 325.155 068 103 085 E ASW WD FPM/ACM 32x47x10 2x</p>	<p>TLS 703.960 </p>

AUDI

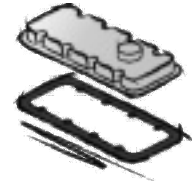
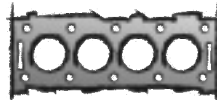
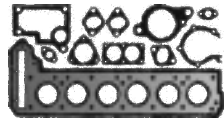

AVV
4 Cyl. **1781 ccm**
Cyl. 81,0 Ø

A4
11/1994 → 09/2001

ES⊕ **183.890 ●**
058 198 012



ES⊕ **264.730**
058 198 012
+058 198 025 A

CS* **670.730**
058 198 011

SZ **863.590**
058 198 217



366.670
058 103 383 Q
1,22 mm $\frac{1}{2}$ 82,5 Ø



ZKS 104.930
058 103 385 A (10x)
M 11x1,5x96



ZKHS 633.350
058 198 025 A



476.020
058 103 483 F

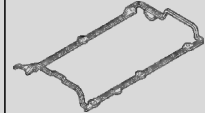

476.030
058 103 484 C

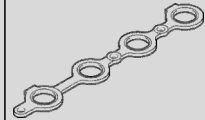

AWL AWM
AWT
4 Cyl. **1781 ccm**
Cyl. 81,0 Ø

A4
01/1995 → 05/2010

A6
01/1997 → 01/2005

ES⊕ **461.380**
CS* **292.011**
SZ **863.590**
058 198 217



366.670
058 103 383 Q
1,22 mm $\frac{1}{2}$ 82,5 Ø

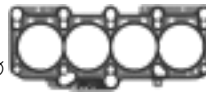

ZKS 130.830
06A 103 385 A (10x)
M 10x1,5x115



ZKHS 633.350
058 198 025 A



476.020
058 103 483 F



476.030
058 103 484 C



BEX BKB
4 Cyl. **1781 ccm**
Cyl. 81,0 Ø

A4
11/2002 → 12/2004

ES⊕ **461.380**
A4 8D2/8D5
→8E-3-500 000

ES⊕ **729.861**
A4 8D2/8D5
8E-4-000 001→

CS **530.580**
06A 198 011 A

SZ **863.590**
058 198 217



366.670
058 103 383 Q
1,22 mm $\frac{1}{2}$ 82,5 Ø



ZKS 130.830
06A 103 385 A (10x)
M 10x1,5x115



ZKHS 633.350
058 198 025 A





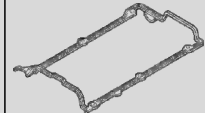













476.020
058 103 483 F



476.030
058 103 484 C



			<p>a) </p> <p>b) </p>	<p>K: </p> <p>N: </p>	
<p>VAS 235.620 FPM 724.590 036 109 675 A FPM 20x</p>	<p>148.190 058 253 039 L </p>	<p>476.460 058 129 717 D </p>	<p>a) 030.793 Dirko HT b) 567.640 N 908 132 01 M 14x1,5x22</p>	<p>K:← 129.780 038 103 085 C ASW RD PTFE/ACM 32x47x10 K:← 325.155 068 103 085 E ASW WD FPM/ACM 32x47x10 K:→ 804.850 028 103 171 K SP LD PTFE/ACM 85 N:← 129.780 038 103 085 C ASW RD PTFE/ACM 32x47x10 2x N:← 325.155 068 103 085 E ASW WD FPM/ACM 32x47x10 2x</p>	
<p>VAS 235.620 FPM 724.590 036 109 675 A FPM 20x</p>	<p>148.190 058 253 039 L </p>	<p>476.460 058 129 717 D </p>	<p>a) 030.793 Dirko HT b) 243.205 N 013 849,3 AL A 14x20x1,5</p>	<p>K:← 155.560 038 103 085 E ASW RD PTFE/ACM 35x48x10 K:← 475.961 054 115 147 B ASW RD FPM 35x48x10 K:→ 012.370 06A 103 171 A IWD LD PTFE/ACM 85 N:← 129.780 038 103 085 C ASW RD PTFE/ACM 32x47x10 2x N:← 325.155 068 103 085 E ASW WD FPM/ACM 32x47x10 2x</p>	<p>TLS 703.960 </p>
<p>VAS 235.620 FPM 724.590 036 109 675 A FPM 20x</p>	<p>148.190 058 253 039 L </p>	<p>476.460 058 129 717 D A4 8D2/8D5 →8E-3-500 000  080.990 06B 129 717 F A4 8D2/8D5 8E-4-000 001→ </p>	<p>a) 030.793 Dirko HT b) 567.640 N 908 132 01 M 14x1,5x22</p>	<p>K:← 155.560 038 103 085 E ASW RD PTFE/ACM 35x48x10 K:→ 012.370 06A 103 171 A IWD LD PTFE/ACM 85 N:← 129.780 038 103 085 C ASW RD PTFE/ACM 32x47x10 2x</p>	<p>TLS 703.960 </p>

AUDI

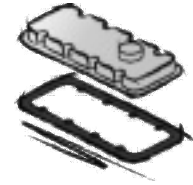
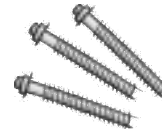
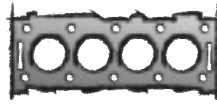
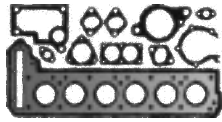

BFB
4 Cyl. **1781 ccm**
Cyl. 81,0 Ø

A4
07/2002 → 03/2009

ES⊕ **461.380**
A4 B6/B7 8E
→8E-3-500 000

A4 B6/B7 8E/8H
→06/2006
ES⊕ **729.861**
A4 B6/B7 8E
8E-4-000 001→

A4 B6/B7 8E/8H
06/2006→
CS **530.580**
06A 198 011 A
SZ **863.590**
058 198 217



366.670
058 103 383 Q
1,22 mm $\frac{3}{4}$ 82,5 Ø



ZKS **130.830**
06A 103 385 A (10x)
M 10x1,5x115

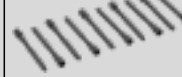

ZKHS **633.350**
058 198 025 A



476.020
058 103 483 F



476.030
058 103 484 C

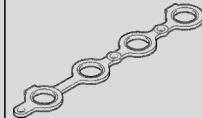

BFV
4 Cyl. **1781 ccm**
Cyl. 81,0 Ø

TT
03/2005 → 06/2006

ES⊕ **461.380**
CS* **292.011**
SZ **863.590**
058 198 217



366.670
058 103 383 Q
1,22 mm $\frac{3}{4}$ 82,5 Ø



ZKS **130.830**
06A 103 385 A (10x)
M 10x1,5x115



ZKHS **633.350**
058 198 025 A



476.020
058 103 483 F



476.030
058 103 484 C



BVP
BVR
4 Cyl. **1781 ccm**
Cyl. 81,0 Ø

TT
09/2005 → 06/2006

ES⊕ **461.380**
CS* **292.011**
SZ **863.590**
058 198 217



366.670
058 103 383 Q
1,22 mm $\frac{3}{4}$ 82,5 Ø



ZKS **130.830**
06A 103 385 A (10x)
M 10x1,5x115



ZKHS **633.350**
058 198 025 A





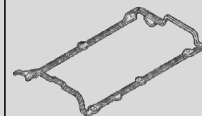













476.020
058 103 483 F



476.030
058 103 484 C



			<p>a) </p> <p>b) </p>	<p>K: </p> <p>N: </p>	
<p>VAS 235.620 FPM 724.590 036 109 675 A FPM 20x</p>	<p>148.190 058 253 039 L </p>	<p>476.460 058 129 717 D A4 B6/B7 8E →8E-3-500 000</p> <hr/> <p>A4 B6/B7 8E/8H →06/2006 </p> <p>080.990 06B 129 717 F A4 B6/B7 8E 8E-4-000 001→</p> <hr/> <p>A4 B6/B7 8E/8H 06/2006→ </p>	<p>a) 030.793 Dirko HT</p> <p>b) 567.640 N 908 132 01 M 14x1,5x22</p>	<p>K:← 155.560 038 103 085 E ASW RD PTFE/ACM 35x48x10</p> <p>K:→ 012.370 06A 103 171 A IWD LD PTFE/ACM 85</p> <p>N:← 129.780 038 103 085 C ASW RD PTFE/ACM 32x47x10 2x</p>	<p>TLS 703.960 </p>
<p>VAS 235.620 FPM 724.590 036 109 675 A FPM 20x</p>	<p>148.190 058 253 039 L </p>	<p>476.460 058 129 717 D </p>	<p>a) 030.793 Dirko HT</p> <p>b) 567.640 N 908 132 01 M 14x1,5x22</p>	<p>K:← 155.560 038 103 085 E ASW RD PTFE/ACM 35x48x10</p> <p>K:→ 012.370 06A 103 171 A IWD LD PTFE/ACM 85</p> <p>N:← 129.780 038 103 085 C ASW RD PTFE/ACM 32x47x10 2x</p>	
<p>VAS 235.620 FPM 724.590 036 109 675 A FPM 20x</p>	<p>148.190 058 253 039 L </p>	<p>476.460 058 129 717 D </p>	<p>a) 030.793 Dirko HT</p> <p>b) 567.640 N 908 132 01 M 14x1,5x22</p>	<p>K:← 155.560 038 103 085 E ASW RD PTFE/ACM 35x48x10</p> <p>K:→ 012.370 06A 103 171 A IWD LD PTFE/ACM 85</p> <p>N:← 129.780 038 103 085 C ASW RD PTFE/ACM 32x47x10 2x</p>	<p>TLS 717.951 </p>

AUDI

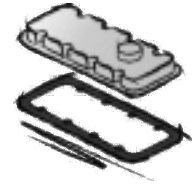

DZ
4 Cyl. **1781 ccm**
Cyl. 81,0 Ø

80
08/1984 → 08/1991

90
08/1989 → 08/1991

Coupé
12/1984 → 07/1991

ES⊕ **693.848**
026 198 012 T
80 (81/85)

CS* **774.731**
037 198 011 C

828.807
026 103 383 S
1,75 mm $\frac{1}{16}$ 83 Ø



ZKS **819.817**
050 103 384 (10x)
M 11x1,5x96

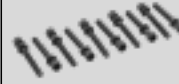

ZKHS **314.773**
026 198 025 A
centr. 8,5 mm



ZKHS **457.200**
026 198 025 C
centr. 6,5 mm



447.050
026 103 483 F

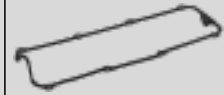

JN
4 Cyl. **1781 ccm**
Cyl. 81,0 Ø

80
08/1983 → 10/1991

Coupé
01/1985 → 07/1988

ES⊕ **834.300**
026 198 012 S

CS* **774.731**
037 198 011 C

828.807
026 103 383 S
1,75 mm $\frac{1}{16}$ 83 Ø



ZKS **819.817**
050 103 384 (10x)
M 11x1,5x96

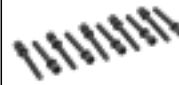

ZKHS **314.773**
026 198 025 A
centr. 8,5 mm























ZKHS **457.200**
026 198 025 C
centr. 6,5 mm



447.050
026 103 483 F



			<p>a) </p> <p>b) </p>	<p>K: </p> <p>N: </p>	
<p>VAS 702.706 FPM 553.190 026 109 675 FPM 8x</p>	<p>815.187 028 129 589 B 4x</p> 	<p>AAS 195.670 026 129 717 D +035 121 171 C 80 (81/85)</p>  <p>460.745 035 121 171 C 80 (81/85)</p>  <p>757.756 026 129 717 D 80 (81/85)</p>  <p>758.825 026 129 717 F 80 (89)</p> 	<p>a) 248.097 028 103 609 A</p>  <p>a) 495.620 044 103 609 D</p>  <p>b) 878.070 N 906 606 01 incl. 115.100 M 14x1,5x16</p> <p>b) 115.100 N 013 849.2 CU A 14x20x1,5</p>	<p>K:← 325.155 068 103 085 E ASW WD FPM/ACM 32x47x10</p> <p>K:→ 342.093 068 103 051 P ASW LD FPM 85x105x11</p> <p>K:→ 829.056 068 198 171 ASW LD FPM 85x105x11</p> <p>N:← 325.155 068 103 085 E ASW WD FPM/ACM 32x47x10</p>	
<p>VAS 702.706 FPM 553.190 026 109 675 FPM 8x</p>	<p>815.187 028 129 589 B 4x</p> 	<p>757.756 026 129 717 D 80 (81/85)</p>  <p>758.825 026 129 717 F 80 (89)</p> 	<p>a) 248.097 028 103 609 A</p>  <p>a) 495.620 044 103 609 D</p>  <p>b) 878.070 N 906 606 01 incl. 115.100 M 14x1,5x16</p> <p>b) 115.100 N 013 849.2 CU A 14x20x1,5</p>	<p>K:← 325.155 068 103 085 E ASW WD FPM/ACM 32x47x10</p> <p>K:→ 342.093 068 103 051 P ASW LD FPM 85x105x11</p> <p>K:→ 804.850 028 103 171 K SP LD PTFE/ACM 85</p> <p>K:→ 829.056 068 198 171 ASW LD FPM 85x105x11</p> <p>N:← 325.155 068 103 085 E ASW WD FPM/ACM 32x47x10</p>	

AUDI

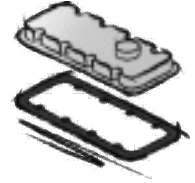
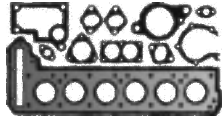

4B **DD**
DR **DS**
JV **JW**
NE **NP**
RS **SH**

4 Cyl. **1781 ccm**
 Cyl. 81,0 Ø

100
 08/1982 → 11/1990
80
 01/1983 → 10/1991
Coupé
 08/1981 → 10/1988

ES⊕ **894.060**
 026 198 012 AB
 CS* **774.731**
 037 198 011 C

828.807
 026 103 383 S
 1,75 mm $\frac{1}{16}$ 83 Ø



ZKS **819.817**
 050 103 384 (10x)
 M 11x1,5x96

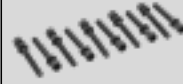

ZKHS **314.773**
 026 198 025 A
 centr. 8,5 mm



ZKHS **457.200**
 026 198 025 C
 centr. 6,5 mm



447.050
 026 103 483 F



PH
PV
 4 Cyl. **1781 ccm**
 Cyl. 81,0 Ø

100
 03/1985 → 11/1990
80
 03/1985 → 08/1986
Coupé
 08/1986 → 10/1987

ES⊕ **834.300**
 026 198 012 S
 CS* **774.731**
 037 198 011 C

828.807
 026 103 383 S
 1,75 mm $\frac{1}{16}$ 83 Ø

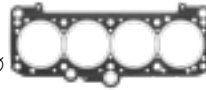

ZKS **819.817**
 050 103 384 (10x)
 M 11x1,5x96

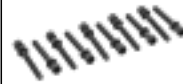

ZKHS **314.773**
 026 198 025 A
 centr. 8,5 mm



ZKHS **457.200**
 026 198 025 C
 centr. 6,5 mm



447.050
 026 103 483 F



PM **RU**
SF
 4 Cyl. **1781 ccm**
 Cyl. 81,0 Ø

80
 02/1986 → 10/1991
Coupé
 04/1986 → 10/1988

ES⊕ **693.848**
 026 198 012 T
 CS* **774.731**
 037 198 011 C

828.807
 026 103 383 S
 1,75 mm $\frac{1}{16}$ 83 Ø



ZKS **819.817**
 050 103 384 (10x)
 M 11x1,5x96

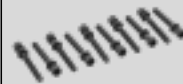

ZKHS **314.773**
 026 198 025 A
 centr. 8,5 mm









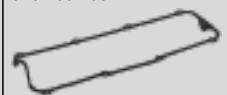











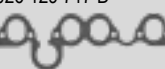

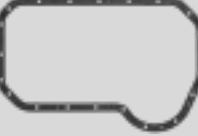









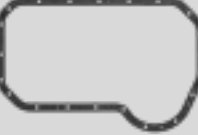

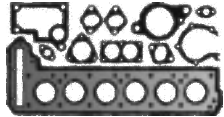
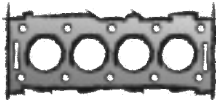

ZKHS **457.200**
 026 198 025 C
 centr. 6,5 mm

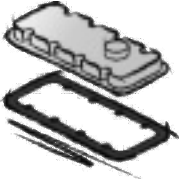
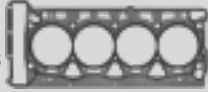

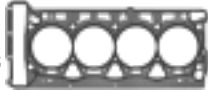



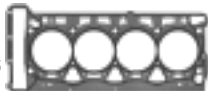

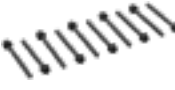



















447.050
 026 103 483 F





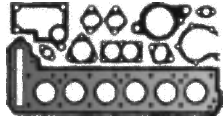
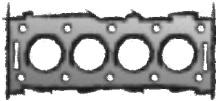

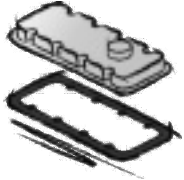
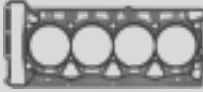

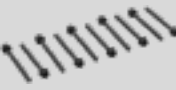
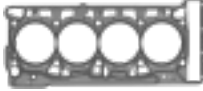
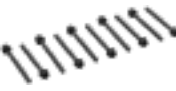
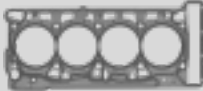
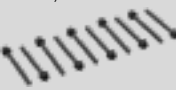
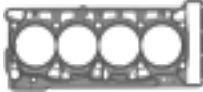
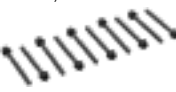





















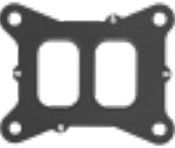

			<p>a) </p> <p>b) </p>	<p>K: </p> <p>N: </p>	
<p>VAS 702.706 FPM 553.190 026 109 675 FPM 8x</p>	<p>815.187 028 129 589 B 4x</p> 	<p>AAS 195.670 026 129 717 D +035 121 171 C</p>  <p>460.745 035 121 171 C</p>  <p>757.756 026 129 717 D</p> 	<p>a) 248.097 028 103 609 A</p>  <p>a) 495.620 044 103 609 D</p>  <p>b) 878.070 N 906 606 01 incl. 115.100 M 14x1,5x16 b) 115.100 N 013 849.2 CU A 14x20x1,5</p>	<p>K:← 325.155 068 103 085 E ASW WD FPM/ACM 32x47x10 K:→ 342.093 068 103 051 P ASW LD FPM 85x105x11 K:→ 829.056 068 198 171 ASW LD FPM 85x105x11 N:← 325.155 068 103 085 E ASW WD FPM/ACM 32x47x10</p>	
<p>VAS 702.706 FPM 553.190 026 109 675 FPM 8x</p>	<p>815.187 028 129 589 B 4x</p> 	<p>757.756 026 129 717 D</p> 	<p>a) 248.097 028 103 609 A</p>  <p>a) 495.620 044 103 609 D</p>  <p>b) 878.070 N 906 606 01 incl. 115.100 M 14x1,5x16 b) 115.100 N 013 849.2 CU A 14x20x1,5</p>	<p>K:← 325.155 068 103 085 E ASW WD FPM/ACM 32x47x10 K:→ 342.093 068 103 051 P ASW LD FPM 85x105x11 K:→ 804.850 028 103 171 K SP LD PTFE/ACM 85 K:→ 829.056 068 198 171 ASW LD FPM 85x105x11 N:← 325.155 068 103 085 E ASW WD FPM/ACM 32x47x10</p>	
<p>VAS 702.706 FPM 553.190 026 109 675 FPM 8x</p>	<p>815.187 028 129 589 B 4x</p> 	<p>AAS 195.670 026 129 717 D +035 121 171 C</p>  <p>460.745 035 121 171 C</p>  <p>757.756 026 129 717 D</p> 	<p>a) 248.097 028 103 609 A</p>  <p>a) 495.620 044 103 609 D</p>  <p>b) 878.070 N 906 606 01 incl. 115.100 M 14x1,5x16 b) 115.100 N 013 849.2 CU A 14x20x1,5</p>	<p>K:← 325.155 068 103 085 E ASW WD FPM/ACM 32x47x10 K:→ 342.093 068 103 051 P ASW LD FPM 85x105x11 K:→ 829.056 068 198 171 ASW LD FPM 85x105x11 N:← 325.155 068 103 085 E ASW WD FPM/ACM 32x47x10</p>	

<p>AUDI</p> 				
<p>BZB</p> <p>4 Cyl. 1798 ccm Cyl. 82,5 Ø</p> <p>A3</p> <p>11/2006 → 05/2013</p>	<p>ES⊕ 295.780 8P-8A018 001→ 8P-8B000 381→</p> <p>CS* 903.201</p>	<p>685.662 06H 103 383 AF 0,90 mm $\frac{\pm}{\pm}$ 83,3 Ø</p>  <p>8P-8B000 381→ 8P-8A018 001→</p>	<p>ZKS 325.930 06D 103 385 D (10x) M 10x1,5x117</p> 	<p>461.682 EL-Liq 74</p>
<p>CABA CABB</p> <p>4 Cyl. 1798 ccm Cyl. 82,5 Ø</p> <p>A4</p> <p>11/2007 → 12/2015</p>	<p>ES⊕ 295.780 →05/2009</p> <p>ES⊕ 244.891 05/2009→</p> <p>CS* 903.201</p>	<p>685.662 06H 103 383 AF 0,90 mm $\frac{\pm}{\pm}$ 83,3 Ø</p> 	<p>ZKS 325.930 06D 103 385 D (10x) M 10x1,5x117</p> 	<p>461.682 EL-Liq 74</p>
<p>CABD</p> <p>4 Cyl. 1798 ccm Cyl. 82,5 Ø</p> <p>A5</p> <p>10/2007 → 01/2017</p>	<p>ES⊕ 295.780</p> <p>CS* 903.201</p>	<p>685.662 06H 103 383 AF 0,90 mm $\frac{\pm}{\pm}$ 83,3 Ø</p> 	<p>ZKS 325.930 06D 103 385 D (10x) M 10x1,5x117</p> 	<p>461.682 EL-Liq 74</p>
<p>CDAA</p> <p>4 Cyl. 1798 ccm Cyl. 82,5 Ø</p> <p>A3</p> <p>11/2006 → 05/2013</p> <p>TT</p> <p>06/2008 → 06/2014</p>	<p>ES⊕ 295.780 →05/2009</p> <p>ES⊕ 244.891 05/2009→</p> <p>CS* 903.201</p>	<p>685.662 06H 103 383 AF 0,90 mm $\frac{\pm}{\pm}$ 83,3 Ø</p> 	<p>ZKS 325.930 06D 103 385 D (10x) M 10x1,5x117 →10/2012</p>  <p>ZKS 323.300 WHT 005 305 (10x) M10x1,5x115 10/2012→</p> 	<p>461.682 EL-Liq 74</p>

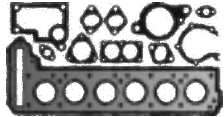
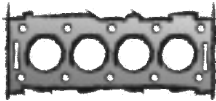

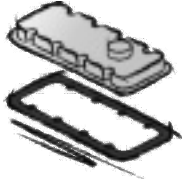
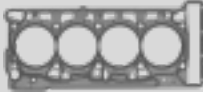
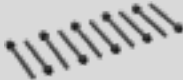
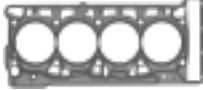
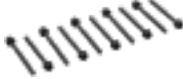

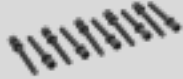

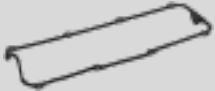











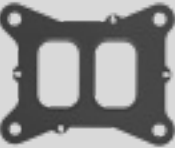

			<p>a) </p> <p>b) </p>	<p>K: </p> <p>N: </p>	
<p>VAS 235.610 FPM 724.590 036 109 675 A FPM 16x</p>	<p>150.860 06F 253 039 F </p>	<p>735.850 06J 129 717 </p>	<p>a) 030.793 Dirko HT</p> <p>b) 567.640 N 908 132 01 M 14x1,5x22</p> <p>b) 858.050 N 911 679 01 incl. 591.840 M 14x1,5x15</p> <p>b) 591.840 N 013 815.8 Metal C 14x20x2</p>	<p>K:← 248.300 06L 103 085 B ASW RD PTFE/ACM 45x60x8</p> <p>K:→ 798.660 06K 103 171 G SP LD PTFE/ACM</p>	<p>TLS 261.160 </p>
<p>VAS 235.610 FPM 724.590 036 109 675 A FPM 16x</p>	<p>150.860 06F 253 039 F </p>	<p>735.850 06J 129 717 →05/2009  655.840 06F 129 717 D 05/2009→ </p>	<p>a) 030.793 Dirko HT</p> <p>b) 567.640 N 908 132 01 M 14x1,5x22</p> <p>b) 858.050 N 911 679 01 incl. 591.840 M 14x1,5x15</p> <p>b) 591.840 N 013 815.8 Metal C 14x20x2</p>	<p>K:← 248.300 06L 103 085 B ASW RD PTFE/ACM 45x60x8</p> <p>K:→ 798.660 06K 103 171 G SP LD PTFE/ACM</p>	<p>TLS 948.660 </p>
<p>VAS 235.610 FPM 724.590 036 109 675 A FPM 16x</p>	<p>150.860 06F 253 039 F </p>	<p>735.850 06J 129 717 </p>	<p>a) 030.793 Dirko HT</p> <p>b) 567.640 N 908 132 01 M 14x1,5x22</p> <p>b) 858.050 N 911 679 01 incl. 591.840 M 14x1,5x15</p> <p>b) 591.840 N 013 815.8 Metal C 14x20x2</p>	<p>K:← 248.300 06L 103 085 B ASW RD PTFE/ACM 45x60x8</p> <p>K:→ 798.660 06K 103 171 G SP LD PTFE/ACM</p>	<p>TLS 948.660 </p>
<p>VAS 235.610 FPM 724.590 036 109 675 A FPM 16x</p>	<p>150.860 06F 253 039 F </p>	<p>735.850 06J 129 717 →05/2009  655.840 06F 129 717 D 05/2009→ </p>	<p>a) 030.793 Dirko HT</p> <p>b) 567.640 N 908 132 01 M 14x1,5x22</p> <p>b) 858.050 N 911 679 01 incl. 591.840 M 14x1,5x15</p> <p>b) 591.840 N 013 815.8 Metal C 14x20x2</p>	<p>K:← 248.300 06L 103 085 B ASW RD PTFE/ACM 45x60x8</p> <p>K:→ 798.660 06K 103 171 G SP LD PTFE/ACM</p>	<p>TLS 261.160 </p>

<p>AUDI</p> 				
<p>CDHA CDHB</p> <p>4 Cyl. 1798 ccm Cyl. 82,5 Ø</p> <p>A4 11/2007 → 12/2015</p> <p>A5 05/2009 → 03/2012</p>	<p>ES⊕ 295.780 →05/2009</p> <p>ES⊕ 244.891 05/2009→</p> <p>CS* 903.201</p>	<p>685.662 06H 103 383 AF 0,90 mm $\frac{\pm}{\pm}$ 83,3 Ø</p> 	<p>ZKS 325.930 06D 103 385 D (10x) M 10x1,5x117 →10/2012</p>  <p>ZKS 323.300 WHT 005 305 (10x) M10x1,5x115 10/2012→</p> 	<p>461.682 EL-Liq 74</p>
<p>CJEB CJED CJEE</p> <p>4 Cyl. 1798 ccm Cyl. 82,5 Ø</p> <p>A4 11/2011 → 12/2015</p> <p>A5 10/2007 → 01/2017</p>	<p>ES⊕ 770.530</p> <p>CS* 877.340</p>	<p>008.040 06K 103 383 K 0,90 mm $\frac{\pm}{\pm}$ 83,3 Ø 12/2013→</p> 	<p>ZKS 323.300 WHT 005 305 (10x) M10x1,5x115</p> 	<p>461.682 EL-Liq 74</p>
<p>CJSA CJSB</p> <p>4 Cyl. 1798 ccm Cyl. 82,5 Ø</p> <p>A3 04/2012 →</p> <p>TT 07/2015 → 08/2018</p>	<p>ES⊕ 313.201</p> <p>CS 798.670</p>	<p>008.040 06K 103 383 K 0,90 mm $\frac{\pm}{\pm}$ 83,3 Ø 12/2013→</p> 	<p>ZKS 323.300 WHT 005 305 (10x) M10x1,5x115</p> 	<p>461.682 EL-Liq 74</p>
<p>CNSB</p> <p>4 Cyl. 1798 ccm Cyl. 82,5 Ø</p> <p>A3 11/2013 → 10/2020</p>	<p>ES⊕ 313.201</p> <p>CS 798.670</p>	<p>008.040 06K 103 383 K 0,90 mm $\frac{\pm}{\pm}$ 83,3 Ø 12/2013→</p> 	<p>ZKS 323.300 WHT 005 305 (10x) M10x1,5x115</p> 	<p>461.682 EL-Liq 74</p>

			<p>a) </p> <p>b) </p>	<p>K: </p> <p>N: </p>	
<p>VAS 235.610 FPM 724.590 036 109 675 A FPM 16x</p>	<p>150.860 06F 253 039 F </p>	<p>735.850 06J 129 717 →05/2009  655.840 06F 129 717 D 05/2009→ </p>	<p>a) 030.793 Dirko HT</p> <p>b) 567.640 N 908 132 01 M 14x1,5x22</p> <p>b) 858.050 N 911 679 01 incl. 591.840 M 14x1,5x15</p> <p>b) 591.840 N 013 815.8 Metal C 14x20x2</p>	<p>K:← 248.300 06L 103 085 B ASW RD PTFE/ACM 45x60x8</p> <p>K:→ 798.660 06K 103 171 G SP LD PTFE/ACM</p>	<p>TLS 948.660 </p>
<p>VAS 235.610 FPM 724.590 036 109 675 A FPM 16x</p>	<p>691.780 06L 253 039 </p>	<p>297.590 06K 129 717 A </p>	<p>a) 030.793 Dirko HT ↑</p> <p>a) 822.480 06L 103 649 S </p> <p>b) 588.690 06L 103 801</p> <p>b) 858.050 N 911 679 01 incl. 591.840 M 14x1,5x15</p> <p>b) 591.840 N 013 815.8 Metal C 14x20x2</p>	<p>K:← 248.300 06L 103 085 B ASW RD PTFE/ACM 45x60x8</p> <p>K:→ 798.660 06K 103 171 G SP LD PTFE/ACM</p>	<p>TLS 878.330 </p>
<p>VAS 235.610 FPM 724.590 036 109 675 A FPM 16x</p>	<p>691.780 06L 253 039 </p>	<p>297.590 06K 129 717 A </p>	<p>a) 030.793 Dirko HT ↑</p> <p>a) 398.260 06K 103 649 </p> <p>b) 588.690 06L 103 801</p>	<p>K:← 248.300 06L 103 085 B ASW RD PTFE/ACM 45x60x8</p> <p>K:→ 798.660 06K 103 171 G SP LD PTFE/ACM</p>	<p>TLS 793.230 </p>
<p>VAS 235.610 FPM 724.590 036 109 675 A FPM 16x</p>	<p>691.780 06L 253 039 </p>	<p>297.590 06K 129 717 A </p>	<p>a) 030.793 Dirko HT ↑</p> <p>a) 398.260 06K 103 649 </p> <p>b) 588.690 06L 103 801</p>	<p>K:← 248.300 06L 103 085 B ASW RD PTFE/ACM 45x60x8</p> <p>K:→ 798.660 06K 103 171 G SP LD PTFE/ACM</p>	

<p>AUDI</p> 				
<p>CYGA</p> <p>4 Cyl. 1798 ccm Cyl. 82,5 Ø</p> <p>A6 09/2014 → 09/2018</p> <p>A7 04/2015 → 05/2018</p>	<p>ES⊕ 770.530 CS* 877.340</p>	<p>008.040 06K 103 383 K 0,90 mm $\frac{3}{8}$ 83,3 Ø</p> 	<p>ZKS 323.300 WHT 005 305 (10x) M10x1,5x115</p> 	<p>461.682 EL-Liq 74</p>
<p>DAJB</p> <p>4 Cyl. 1798 ccm Cyl. 82,5 Ø</p> <p>A1 02/2015 → 10/2018</p>	<p>ES⊕ 313.201 CS 798.670</p>	<p>008.040 06K 103 383 K 0,90 mm $\frac{3}{8}$ 83,3 Ø</p> 	<p>ZKS 323.300 WHT 005 305 (10x) M10x1,5x115</p> 	<p>461.682 EL-Liq 74</p>
<p>SD</p> <p>4 Cyl. 1847 ccm Cyl. 82,5 Ø</p> <p>80 09/1986 → 08/1990</p>	<p>ES⊕ 765.636 053 198 012 A CS* 774.731 037 198 011 C</p>	<p>915.591 048 103 383 B 1,75 mm $\frac{3}{8}$ 83 Ø</p> 	<p>ZKS 819.817 050 103 384 (10x) M 11x1,5x96</p> 	<p>ZKHS 314.773 026 198 025 A centr. 8,5 mm</p>  <p>ZKHS 457.200 026 198 025 C centr. 6,5 mm</p>  <p>447.050 026 103 483 F</p> 

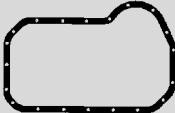
AUDI

			<p>a) </p> <p>b) </p>	<p>K: </p> <p>N: </p>	
<p>VAS 235.610 FPM 724.590 036 109 675 A FPM 16x</p>	<p>691.780 06L 253 039</p> 	<p>297.590 06K 129 717 A</p> 	<p>a) 030.793 Dirko HT ↑</p> <p>a) 822.480 06L 103 649 S</p>  <p>b) 588.690 06L 103 801</p>	<p>K:← 248.300 06L 103 085 B ASW RD PTFE/ACM 45x60x8</p> <p>K:→ 798.660 06K 103 171 G SP LD PTFE/ACM</p>	<p>TLS 878.330</p> 
<p>VAS 235.610 FPM 724.590 036 109 675 A FPM 16x</p>	<p>691.780 06L 253 039</p> 	<p>297.590 06K 129 717 A</p> 	<p>a) 030.793 Dirko HT ↑</p> <p>a) 398.260 06K 103 649</p>  <p>b) 588.690 06L 103 801</p>	<p>K:← 248.300 06L 103 085 B ASW RD PTFE/ACM 45x60x8</p> <p>K:→ 798.660 06K 103 171 G SP LD PTFE/ACM</p>	<p>TLS 793.230</p> 
<p>VAS 702.706 FPM 553.190 026 109 675 FPM 8x</p>	<p>815.187 028 129 589 B 4x</p> 	<p>758.825 026 129 717 F</p> 	<p>a) 248.097 028 103 609 A</p>  <p>a) 495.620 044 103 609 D</p>  <p>b) 878.070 N 906 606 01 incl. 115.100 M 14x1,5x16</p> <p>b) 115.100 N 013 849.2 CU A 14x20x1,5</p>	<p>K:← 325.155 068 103 085 E ASW WD FPM/ACM 32x47x10</p> <p>K:→ 342.093 068 103 051 P ASW LD FPM 85x105x11</p> <p>K:→ 829.056 068 198 171 ASW LD FPM 85x105x11</p> <p>N:← 325.155 068 103 085 E ASW WD FPM/ACM 32x47x10</p>	

AUDI



1Y
4 Cyl. **1896 ccm**
Cyl. 79,5 Ø

80
08/1989 → 08/1991

ES⊕ **915.130**
028 198 012 B
→Mot. 1Y 580 000



ES⊕ **187.390**
028 198 012 E
Mot. 1Y 580 001→



CS* **670.720**
028 198 011 D
→Mot. 1Y 800 000



CS* **375.540**
Mot. 1Y 800 001→



914.848
028 103 383 BH
→ 0,660 mm
→ 0,860 mm
1,53 mm ± 81 Ø
1 ⊗



914.856
028 103 383 BJ
→ 0,870 mm
→ 0,920 mm
1,57 mm ± 81 Ø
2 ⊗



914.873
028 103 383 BK
→ 0,930 mm
→ 1,020 mm
1,61 mm ± 81 Ø
3 ⊗



ZKS **819.824**
068 103 384 A (10x)
M 12x1,75x115

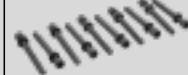

ZKHS **413.690**
028 198 025

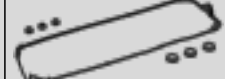

830.773
028 103 483 H

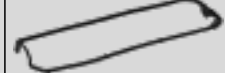

915.017
028 103 533
3x



915.009
028 103 532 A
3x



1Z
4 Cyl. **1896 ccm**
Cyl. 79,5 Ø

80 TDI
09/1991 → 01/1996

A4 TDI
01/1995 → 09/2001

A6 TDI
06/1994 → 12/1997

Cabrio TDI
06/1995 → 08/2000

ES⊕ **620.280**
028 198 012 C
→Mot. 1Z 770 000



ES⊕ **187.400**
028 198 012 F
Mot. 1Z 770 001→



CS* **670.720**
028 198 011 D



412.872
028 103 383 BP
→ 0,910 mm
→ 1,000 mm
1,45 mm ± 80,5 Ø
1 ⊗



412.882
028 103 383 BQ
→ 1,010 mm
→ 1,100 mm
1,53 mm ± 80,5 Ø
2 ⊗

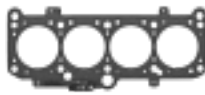

412.912
028 103 383 BR
→ 1,110 mm
→ 1,200 mm
1,61 mm ± 80,5 Ø
3 ⊗



ZKS **819.824**
068 103 384 A (10x)
M 12x1,75x115

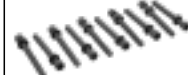

ZKHS **470.280**



619.771
028 103 483 G



















915.017
028 103 533
3x

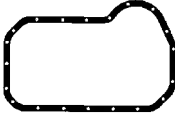

915.009
028 103 532 A
3x



			<p>a) </p> <p>b) </p>	<p>K: </p> <p>N: </p>	
<p>VAS 702.706 FPM →Mot. 1Y 580 000</p> <p>VAS 825.042 FPM Mot. 1Y 580 001→</p> <p>553.190 026 109 675 FPM →Mot. 1Y 580 000 8x</p> <p>701.289 027 109 675 FPM Mot. 1Y 580 001→ 8x</p>	<p>815.187 028 129 589 B 4x</p> 	<p>915.213 028 129 717 D</p> 	<p>a) 447.340 037 115 220 B</p>  <p>b) 878.070 N 906 606 01 incl. 115.100 M 14x1,5x16</p> <p>b) 115.100 N 013 849.2 CU A 14x20x1,5</p>	<p>K:← 325.155 068 103 085 E ASW WD FPM/ACM 32x47x10</p> <p>K:→ 342.093 068 103 051 P ASW LD FPM 85x105x11 →Mot. 1Y 800 000</p> <p>K:→ 829.056 068 198 171 ASW LD FPM 85x105x11 →Mot. 1Y 800 000</p> <p>K:→ 804.850 028 103 171 K SP LD PTFE/ACM 85 Mot. 1Y 800 001→</p> <p>N:← 325.155 068 103 085 E ASW WD FPM/ACM 32x47x10</p>	
<p>VAS 702.706 FPM →Mot. 1Z 770 000</p> <p>VAS 825.042 FPM Mot. 1Z 770 001→</p> <p>553.190 026 109 675 FPM →Mot. 1Z 770 000 8x</p> <p>701.289 027 109 675 FPM Mot. 1Z 770 001→ 8x</p>	<p>815.187 028 129 589 B 4x</p> 	<p>915.213 028 129 717 D</p> 	<p>a) 248.097 028 103 609 A</p>  <p>a) 495.620 044 103 609 D</p>  <p>b) 878.070 N 906 606 01 incl. 115.100 M 14x1,5x16</p> <p>b) 115.100 N 013 849.2 CU A 14x20x1,5</p>	<p>K:← 325.155 068 103 085 E ASW WD FPM/ACM 32x47x10</p> <p>K:→ 342.093 068 103 051 P ASW LD FPM 85x105x11</p> <p>K:→ 804.850 028 103 171 K SP LD PTFE/ACM 85</p> <p>K:→ 829.056 068 198 171 ASW LD FPM 85x105x11</p> <p>N:← 325.155 068 103 085 E ASW WD FPM/ACM 32x47x10</p>	<p>TLS 703.970</p>  <p>TLS 896.200</p> 

AUDI

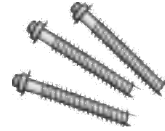
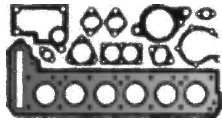

AAZ
4 Cyl. **1896 ccm**
Cyl. 79,5 Ø

80 TD
09/1991 → 12/1994

ES⊕ **915.130**
028 198 012 B

CS* **670.720**
028 198 011 D

914.848
028 103 383 BH
 0,660 mm
→
0,860 mm
1,53 mm $\frac{\pm}{\pm}$ 81 Ø
1 ⊗

914.856
028 103 383 BJ
 0,870 mm
→
0,920 mm
1,57 mm $\frac{\pm}{\pm}$ 81 Ø
2 ⊗

914.873
028 103 383 BK
 0,930 mm
→
1,020 mm
1,61 mm $\frac{\pm}{\pm}$ 81 Ø
3 ⊗

ZKS 819.824
068 103 384 A (10x)
M 12x1,75x115

ZKHS 413.690
028 198 025

830.773
028 103 483 H

915.017
028 103 533
3x
 FE

915.009
028 103 532 A
3x
 FE

AFF
4 Cyl. **1896 ccm**
Cyl. 79,5 Ø

A4 TDI
12/1995 → 09/2001

ES⊕ **620.280**
028 198 012 C
→Mot. AFF 002 000

ES⊕ **187.400**
028 198 012 F
Mot. AFF 002 001→

CS* **670.720**
028 198 011 D
→12/1997

CS* **375.540**
01/1998→

412.872
028 103 383 BP
 0,910 mm
→
1,000 mm
1,45 mm $\frac{\pm}{\pm}$ 80,5 Ø
1 ⊗

412.882
028 103 383 BQ
 1,010 mm
→
1,100 mm
1,53 mm $\frac{\pm}{\pm}$ 80,5 Ø
2 ⊗

412.912
028 103 383 BR
 1,110 mm
→
1,200 mm
1,61 mm $\frac{\pm}{\pm}$ 80,5 Ø
3 ⊗

ZKS 819.824
068 103 384 A (10x)
M 12x1,75x115

















ZKHS 470.280

619.771
028 103 483 G

915.017
028 103 533
3x
 FE

915.009
028 103 532 A
3x
 FE

AUDI

			<p>a) </p> <p>b) </p>	<p>K: </p> <p>N: </p>	
<p>VAS 702.706 FPM 553.190 026 109 675 FPM 8x</p>	<p>815.187 028 129 589 B 4x</p> 	<p>915.213 028 129 717 D</p> 	<p>a) 447.340 037 115 220 B</p>  <p>b) 878.070 N 906 606 01 incl. 115.100 M 14x1,5x16</p> <p>b) 115.100 N 013 849.2 CU A 14x20x1,5</p>	<p>K:← 325.155 068 103 085 E ASW WD FPM/ACM 32x47x10</p> <p>K:→ 342.093 068 103 051 P ASW LD FPM 85x105x11</p> <p>K:→ 804.850 028 103 171 K SP LD PTFE/ACM 85</p> <p>K:→ 829.056 068 198 171 ASW LD FPM 85x105x11</p> <p>N:← 325.155 068 103 085 E ASW WD FPM/ACM 32x47x10</p>	<p>TLS 703.970 08/1993→</p> 
<p>VAS 702.706 FPM →Mot. AFF 002 000</p> <p>VAS 825.042 FPM Mot. AFF 002 001→</p> <p>553.190 026 109 675 FPM →Mot. AFF 002 000 8x</p> <p>701.289 027 109 675 FPM Mot. AFF 002 001→ 8x</p>	<p>815.187 028 129 589 B 4x</p> 	<p>915.213 028 129 717 D</p> 	<p>a) 495.620 044 103 609 D →8D-X-260 000</p>  <p>a) 030.793 Dirko HT 8D-X-260 001→</p> <p>b) 878.070 N 906 606 01 incl. 115.100 M 14x1,5x16</p> <p>b) 115.100 N 013 849.2 CU A 14x20x1,5</p>	<p>K:← 325.155 068 103 085 E ASW WD FPM/ACM 32x47x10</p> <p>K:→ 342.093 068 103 051 P ASW LD FPM 85x105x11</p> <p>K:→ 804.850 028 103 171 K SP LD PTFE/ACM 85</p> <p>K:→ 829.056 068 198 171 ASW LD FPM 85x105x11</p> <p>N:← 325.155 068 103 085 E ASW WD FPM/ACM 32x47x10</p>	<p>TLS 703.970</p> 

AUDI

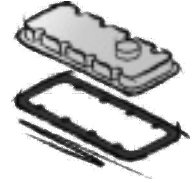
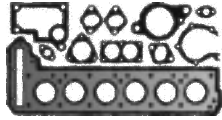

AFN
4 Cyl. **1896 ccm**
Cyl. 79,5 Ø

A4 TDI
10/1995 → 09/2001

A6 TDI
04/1997 → 04/2001

ES⊕ **620.280**
028 198 012 C
→Mot. AFN 002 000



ES⊕ **187.400**
028 198 012 F
Mot. AFN 002 001→



CS* **670.720**
028 198 011 D
→Mot. AFN 576 000



CS* **375.540**
Mot. AFN 576 001→



412.872
028 103 383 BP
0,910 mm
→
1,000 mm



1,45 mm \pm 80,5 Ø
1 ⊗

412.882
028 103 383 BQ
1,010 mm
→
1,100 mm



1,53 mm \pm 80,5 Ø
2 ⊗

412.912
028 103 383 BR
1,110 mm
→
1,200 mm



1,61 mm \pm 80,5 Ø
3 ⊗

ZKS 819.824
068 103 384 A (10x)
M 12x1,75x115

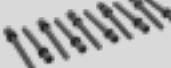

ZKHS 470.280



619.771
028 103 483 G















915.017
028 103 533
3x



915.009
028 103 532 A
3x

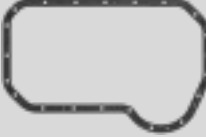

AUDI

			<p>a) </p> <p>b) </p>	<p>K: </p> <p>N: </p>	
<p>VAS 702.706 FPM →Mot. AFN 002 000</p> <p>VAS 825.042 FPM Mot. AFN 002 001→</p> <p>553.190 026 109 675 FPM →Mot. AFN 002 000 8x</p> <p>701.289 027 109 675 FPM Mot. AFN 002 001→ 8x</p>	<p>815.187 028 129 589 B 4x</p> 	<p>915.213 028 129 717 D</p> 	<p>a) 495.620 044 103 609 D →8D-X-260 000 →4B-X-131 000</p>  <p>b) 030.793 Dirko HT 4B-X-131 001→ 8D-X-260 001→</p> <p>878.070 N 906 606 01 incl. 115.100 M 14x1,5x16</p> <p>115.100 N 013 849.2 CU A 14x20x1,5</p>	<p>K:← 325.155 068 103 085 E ASW WD FPM/ACM 32x47x10</p> <p>K:→ 342.093 068 103 051 P ASW LD FPM 85x105x11</p> <p>K:→ 804.850 028 103 171 K SP LD PTFE/ACM 85</p> <p>K:→ 829.056 068 198 171 ASW LD FPM 85x105x11</p> <p>N:← 325.155 068 103 085 E ASW WD FPM/ACM 32x47x10</p>	<p>TLS 703.990 →07/1997</p>  <p>TLS 703.980 08/1997→</p> 

AUDI

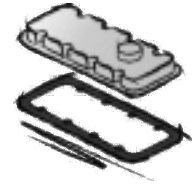

AGR
4 Cyl. **1896 ccm**
Cyl. 79,5 Ø

A3 TDI
09/1996 → 07/2001

ES⊕ **530.560**
038 198 012



CS* **530.541**

165.041
0,910 mm
→
1,000 mm
1,45 mm $\frac{+}{-}$ 80,5 Ø
1 ⊗
→Mot. AGR 151
000

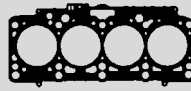

165.011
1,010 mm
→
1,100 mm
1,53 mm $\frac{+}{-}$ 80,5 Ø
2 ⊗
→Mot. AGR 151
000

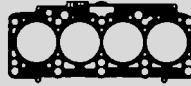

164.991
1,110 mm
→
1,200 mm
1,61 mm $\frac{+}{-}$ 80,5 Ø
3 ⊗
→Mot. AGR 151
000

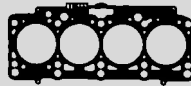

123.992
038 103 383 AL
0,910 mm
→
1,000 mm
1,55 mm $\frac{+}{-}$ 80,5 Ø
1 ⊗
Mot. AGR 151
001→



124.002
038 103 383 AM
1,010 mm
→
1,100 mm
1,63 mm $\frac{+}{-}$ 80,5 Ø
2 ⊗
Mot. AGR 151
001→



124.012
038 103 383 AN
1,110 mm
→
1,200 mm
1,71 mm $\frac{+}{-}$ 80,5 Ø
3 ⊗
Mot. AGR 151
001→













ZKS 819.824
068 103 384 A (10x)
M 12x1,75x115



475.970
038 103 533
3x
→Mot. AGR 044 441

475.980
038 103 532
3x
→Mot. AGR 044 441



			<p>a) </p> <p>b) </p>	<p>K: </p> <p>N: </p>	
<p>VAS 825.042 FPM 701.289 027 109 675 FPM 8x</p>	<p>815.187 028 129 589 B 4x</p> 	<p>915.213 028 129 717 D</p> 	<p>a) 030.793 Dirko HT</p> <p>b) 567.640 N 908 132 01 M 14x1,5x22</p> <p>b) 878.070 N 906 606 01 incl. 115.100 M 14x1,5x16</p> <p>b) 115.100 N 013 849.2 CU A 14x20x1,5</p>	<p>K:← 155.560 038 103 085 E ASW RD PTFE/ACM 35x48x10</p> <p>K:← 475.961 054 115 147 B ASW RD FPM 35x48x10</p> <p>K:→ 012.370 06A 103 171 A IWD LD PTFE/ACM 85</p> <p>N:← 129.780 038 103 085 C ASW RD PTFE/ACM 32x47x10</p> <p>N:← 325.155 068 103 085 E ASW WD FPM/ACM 32x47x10</p>	<p>TLS 704.010</p> 

AUDI



AHF
4 Cyl. **1896 ccm**
Cyl. 79,5 Ø

A3 TDI
08/1997 → 07/2001

ES⊕ **530.560**
038 198 012



CS* **530.541**

165.041
0,910 mm
→
1,000 mm
1,45 mm $\frac{3}{4}$ 80,5 Ø
1 ⊗
→Mot. AHF 140
000

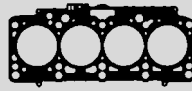

165.011
1,010 mm
→
1,100 mm
1,53 mm $\frac{3}{4}$ 80,5 Ø
2 ⊗
→Mot. AHF 140
000

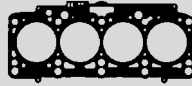

164.991
1,110 mm
→
1,200 mm
1,61 mm $\frac{3}{4}$ 80,5 Ø
3 ⊗
→Mot. AHF 140
000

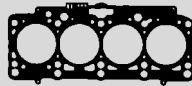

123.992
038 103 383 AL
0,910 mm
→
1,000 mm
1,55 mm $\frac{3}{4}$ 80,5 Ø
1 ⊗
Mot. AHF 140
001→



124.002
038 103 383 AM
1,010 mm
→
1,100 mm
1,63 mm $\frac{3}{4}$ 80,5 Ø
2 ⊗
Mot. AHF 140
001→



124.012
038 103 383 AN
1,110 mm
→
1,200 mm
1,71 mm $\frac{3}{4}$ 80,5 Ø
3 ⊗
Mot. AHF 140
001→













ZKS 819.824
068 103 384 A (10x)
M 12x1,75x115



475.970
038 103 533
3x
→Mot. AHF 006 065

475.980
038 103 532
3x
→Mot. AHF 006 065



			<p>a) </p> <p>b) </p>	<p>K: </p> <p>N: </p>	
<p>VAS 825.042 FPM 701.289 027 109 675 FPM 8x</p>	<p>815.187 028 129 589 B 4x</p> 	<p>915.213 028 129 717 D</p> 	<p>a) 030.793 Dirko HT</p> <p>b) 567.640 N 908 132 01 M 14x1,5x22</p> <p>b) 878.070 N 906 606 01 incl. 115.100 M 14x1,5x16</p> <p>b) 115.100 N 013 849.2 CU A 14x20x1,5</p>	<p>K:← 155.560 038 103 085 E ASW RD PTFE/ACM 35x48x10</p> <p>K:← 475.961 054 115 147 B ASW RD FPM 35x48x10</p> <p>K:→ 012.370 06A 103 171 A IWD LD PTFE/ACM 85</p> <p>N:← 129.780 038 103 085 C ASW RD PTFE/ACM 32x47x10</p> <p>N:← 325.155 068 103 085 E ASW WD FPM/ACM 32x47x10</p>	<p>TLS 704.020</p> 

AUDI

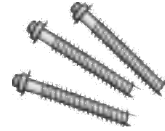
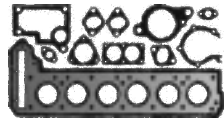

AHH
4 Cyl. **1896 ccm**
Cyl. 79,5 Ø

A4 TDI
01/1995 → 09/2001

ES⊕ **187.400**
028 198 012 F



CS* **375.540**



412.872
028 103 383 BP
0,910 mm
→
1,000 mm
1,45 mm $\frac{+}{-}$ 80,5 Ø
1 ⊗



412.882
028 103 383 BQ
1,010 mm
→
1,100 mm
1,53 mm $\frac{+}{-}$ 80,5 Ø
2 ⊗

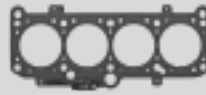

412.912
028 103 383 BR
1,110 mm
→
1,200 mm
1,61 mm $\frac{+}{-}$ 80,5 Ø
3 ⊗



ZKS 819.824
068 103 384 A (10x)
M 12x1,75x115

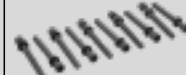

ZKHS 470.280



619.771
028 103 483 G

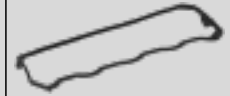

915.017
028 103 533
3x



915.009
028 103 532 A
3x



AHU
4 Cyl. **1896 ccm**
Cyl. 79,5 Ø

A4 DUO
03/1998 → 06/2000

A4 TDI
01/1995 → 09/2001

A6 TDI
06/1994 → 12/1997

Cabrio TDI
06/1995 → 08/2000

ES⊕ **187.400**
028 198 012 F



CS* **670.720**
028 198 011 D
→Mot. AHU 390 000



CS* **375.540**
Mot. AHU 390 001→



412.872
028 103 383 BP
0,910 mm
→
1,000 mm
1,45 mm $\frac{+}{-}$ 80,5 Ø
1 ⊗



412.882
028 103 383 BQ
1,010 mm
→
1,100 mm
1,53 mm $\frac{+}{-}$ 80,5 Ø
2 ⊗



412.912
028 103 383 BR
1,110 mm
→
1,200 mm
1,61 mm $\frac{+}{-}$ 80,5 Ø
3 ⊗



ZKS 819.824
068 103 384 A (10x)
M 12x1,75x115



ZKHS 470.280



619.771
028 103 483 G



















915.017
028 103 533
3x



915.009
028 103 532 A
3x



			<p>a) </p> <p>b) </p>	<p>K: </p> <p>N: </p>	
<p>VAS 825.042 FPM 701.289 027 109 675 FPM 8x</p>	<p>815.187 028 129 589 B 4x</p> 	<p>915.213 028 129 717 D</p> 	<p>a) 495.620 044 103 609 D →8D-X-260 000</p>  <p>a) 030.793 Dirko HT 8D-X-260 001→</p> <p>b) 878.070 N 906 606 01 incl. 115.100 M 14x1,5x16</p> <p>b) 115.100 N 013 849.2 CU A 14x20x1,5</p>	<p>K:← 129.780 038 103 085 C ASW RD PTFE/ACM 32x47x10</p> <p>K:← 325.155 068 103 085 E ASW WD FPM/ACM 32x47x10</p> <p>K:→ 804.850 028 103 171 K SP LD PTFE/ACM 85</p> <p>N:← 325.155 068 103 085 E ASW WD FPM/ACM 32x47x10</p>	<p>TLS 703.980</p> 
<p>VAS 825.042 FPM 701.289 027 109 675 FPM 8x</p>	<p>815.187 028 129 589 B 4x</p> 	<p>915.213 028 129 717 D</p> 	<p>a) 495.620 044 103 609 D →8D-X-260 000</p>  <p>a) 030.793 Dirko HT 8D-X-260 001→</p> <p>b) 878.070 N 906 606 01 incl. 115.100 M 14x1,5x16</p> <p>b) 115.100 N 013 849.2 CU A 14x20x1,5</p>	<p>K:← 325.155 068 103 085 E ASW WD FPM/ACM 32x47x10</p> <p>K:→ 342.093 068 103 051 P ASW LD FPM 85x105x11 →Mot. AHU 390 000</p> <p>K:→ 829.056 068 198 171 ASW LD FPM 85x105x11 →Mot. AHU 390 000</p> <p>K:→ 804.850 028 103 171 K SP LD PTFE/ACM 85 Mot. AHU 390 001→</p> <p>N:← 325.155 068 103 085 E ASW WD FPM/ACM 32x47x10</p>	<p>TLS 703.970</p> 

AUDI

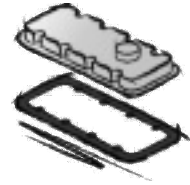
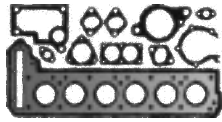

ALH
4 Cyl. **1896 ccm**
Cyl. 79,5 Ø

A3 TDI
09/1996 → 07/2001

ES⊕ **530.560**
038 198 012



CS* **530.541**

165.041
0,910 mm
→
1,000 mm
1,45 mm $\frac{+}{-}$ 80,5 Ø
1 ⊗
→Mot. ALH 085
000

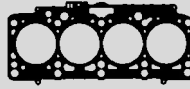

165.011
1,010 mm
→
1,100 mm
1,53 mm $\frac{+}{-}$ 80,5 Ø
2 ⊗
→Mot. ALH 085
000

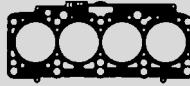

164.991
1,110 mm
→
1,200 mm
1,61 mm $\frac{+}{-}$ 80,5 Ø
3 ⊗
→Mot. ALH 085
000

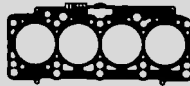

123.992
038 103 383 AL
0,910 mm
→
1,000 mm
1,55 mm $\frac{+}{-}$ 80,5 Ø
1 ⊗
Mot. ALH 085
001→



124.002
038 103 383 AM
1,010 mm
→
1,100 mm
1,63 mm $\frac{+}{-}$ 80,5 Ø
2 ⊗
Mot. ALH 085
001→













124.012
038 103 383 AN
1,110 mm
→
1,200 mm
1,71 mm $\frac{+}{-}$ 80,5 Ø
3 ⊗
Mot. ALH 085
001→



ZKS 819.824
068 103 384 A (10x)
M 12x1,75x115



			<p>a) </p> <p>b) </p>	<p>K: </p> <p>N: </p>	
<p>VAS 825.042 FPM 701.289 027 109 675 FPM 8x</p>	<p>815.187 028 129 589 B 4x</p> 	<p>915.213 028 129 717 D</p> 	<p>a) 030.793 Dirko HT</p> <p>b) 567.640 N 908 132 01 M 14x1,5x22</p> <p>b) 878.070 N 906 606 01 incl. 115.100 M 14x1,5x16</p> <p>b) 115.100 N 013 849.2 CU A 14x20x1,5</p>	<p>K:← 155.560 038 103 085 E ASW RD PTFE/ACM 35x48x10</p> <p>K:← 475.961 054 115 147 B ASW RD FPM 35x48x10</p> <p>K:→ 012.370 06A 103 171 A IWD LD PTFE/ACM 85</p> <p>N:← 129.780 038 103 085 C ASW RD PTFE/ACM 32x47x10</p> <p>N:← 325.155 068 103 085 E ASW WD FPM/ACM 32x47x10</p>	<p>TLS 704.020</p> 

AUDI

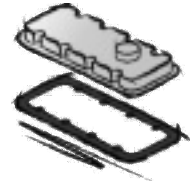
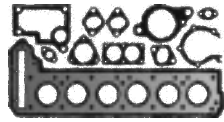

ASV
4 Cyl. **1896 ccm**
Cyl. 79,5 Ø

A3 TDI
08/1997 → 07/2001

ES⊕ **530.560**
038 198 012



CS* **530.541**

123.992
038 103 383 AL
0,910 mm
→
1,000 mm
1,55 mm $\frac{2}{3}$ 80,5 Ø
1 ⊗



124.002
038 103 383 AM
1,010 mm
→
1,100 mm
1,63 mm $\frac{2}{3}$ 80,5 Ø
2 ⊗



124.012
038 103 383 AN
1,110 mm
→
1,200 mm
1,71 mm $\frac{2}{3}$ 80,5 Ø
3 ⊗



ZKS 819.824
068 103 384 A (10x)
M 12x1,75x115



ASZ **ATD**
AXR
4 Cyl. **1896 ccm**
Cyl. 79,5 Ø

A3 TDI
08/2000 → 05/2003

ES⊕ **655.360**



CS* **530.541**

150.153
038 103 383 DE
0,910 mm
→
1,000 mm
1,49 mm $\frac{2}{3}$ 80,5 Ø
1 ⊗



150.162
038 103 383 DF
1,010 mm
→
1,100 mm
1,57 mm $\frac{2}{3}$ 80,5 Ø
2 ⊗



150.172
038 103 383 DG
1,110 mm
→
1,200 mm
1,65 mm $\frac{2}{3}$ 80,5 Ø
3 ⊗



ZKS 057.240
038 103 384 (10x)
M 12x1,75x172



ZKHS 726.290
038 103 483 E
+038 128 773 (13x)



577.240
038 103 483 E

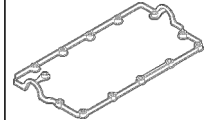

AJM
ATJ
4 Cyl. **1896 ccm**
Cyl. 79,5 Ø

A4 TDI
03/2000 → 09/2001

A6 TDI
07/2000 → 01/2005

ES⊕ **548.141**



ES⊕ **724.341**



CS* **530.541**

150.153
038 103 383 DE
0,910 mm
→
1,000 mm
1,49 mm $\frac{2}{3}$ 80,5 Ø
1 ⊗



150.162
038 103 383 DF
1,010 mm
→
1,100 mm
1,57 mm $\frac{2}{3}$ 80,5 Ø
2 ⊗



150.172
038 103 383 DG
1,110 mm
→
1,200 mm
1,65 mm $\frac{2}{3}$ 80,5 Ø
3 ⊗



ZKS 057.240
038 103 384 (10x)
M 12x1,75x172





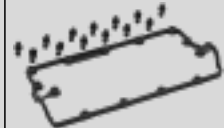



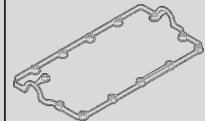









ZKHS 726.290
038 103 483 E
+038 128 773 (13x)



577.240
038 103 483 E



			<p>a) </p> <p>b) </p>	<p>K: </p> <p>N: </p>	
<p>VAS 825.042 FPM 701.289 027 109 675 FPM 8x</p>	<p>815.187 028 129 589 B 4x</p> 	<p>915.213 028 129 717 D</p> 	<p>a) 030.793 Dirko HT</p> <p>b) 567.640 N 908 132 01 M 14x1,5x22</p>	<p>K:← 155.560 038 103 085 E ASW RD PTFE/ACM 35x48x10</p> <p>K:← 475.961 054 115 147 B ASW RD FPM 35x48x10</p> <p>K:→ 012.370 06A 103 171 A IWD LD PTFE/ACM 85</p> <p>N:← 325.155 068 103 085 E ASW WD FPM/ACM 32x47x10</p>	<p>TLS 704.020</p> 
<p>VAS 825.042 FPM 701.289 027 109 675 FPM 8x</p>	<p>625.760 037 253 039 D</p> 	<p>915.213 028 129 717 D</p> 	<p>a) 030.793 Dirko HT</p> <p>b) 567.640 N 908 132 01 M 14x1,5x22</p>	<p>K:← 155.560 038 103 085 E ASW RD PTFE/ACM 35x48x10</p> <p>K:→ 012.370 06A 103 171 A IWD LD PTFE/ACM 85</p> <p>N:← 129.780 038 103 085 C ASW RD PTFE/ACM 32x47x10</p>	<p>TLS 704.020</p> 
<p>VAS 825.042 FPM 701.289 027 109 675 FPM 8x</p>	<p>049.930 037 253 039 F</p> 	<p>915.213 028 129 717 D</p> 	<p>a) 030.793 Dirko HT</p> <p>b) 567.640 N 908 132 01 M 14x1,5x22</p>	<p>K:← 155.560 038 103 085 E ASW RD PTFE/ACM 35x48x10</p> <p>K:→ 012.370 06A 103 171 A IWD LD PTFE/ACM 85</p> <p>N:← 129.780 038 103 085 C ASW RD PTFE/ACM 32x47x10</p>	<p>TLS 703.980</p> 

AUDI



AVB **AVF**
AWX
4 Cyl. **1896 ccm**
Cyl. 79,5 Ø

A4 TDI
11/2000 → 12/2004
A6 TDI
08/2001 → 01/2005

ES⊕ **655.360**



ES⊕ **330.340**



ES⊕ **428.880**
incl. 038 128 773
04/2001→



CS* **530.541**

150.153
038 103 383 DE
0,910 mm
→
1,000 mm
1,49 mm ± 80,5 Ø
1 ⊗



150.162
038 103 383 DF
1,010 mm
→
1,100 mm
1,57 mm ± 80,5 Ø
2 ⊗



150.172
038 103 383 DG
1,110 mm
→
1,200 mm
1,65 mm ± 80,5 Ø
3 ⊗



ZKS 057.240
038 103 384 (10x)
M 12x1,75x172



ZKHS 726.290
038 103 483 E
+038 128 773 (13x)
→03/2001



ZKHS 383.280
038 103 483 D
+038 128 773 (13x)
04/2001→

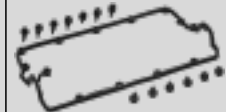

577.240
038 103 483 E
→03/2001



266.060
038 103 483 D
04/2001→

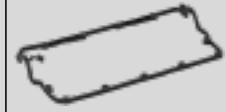

AVG
4 Cyl. **1896 ccm**
Cyl. 79,5 Ø

A4 TDI
10/1995 → 09/2001
A6 TDI
04/1997 → 04/2001

ES⊕ **187.400**
028 198 012 F



CS* **375.540**



412.872
028 103 383 BP
0,910 mm
→
1,000 mm
1,45 mm ± 80,5 Ø
1 ⊗



412.882
028 103 383 BQ
1,010 mm
→
1,100 mm
1,53 mm ± 80,5 Ø
2 ⊗



412.912
028 103 383 BR
1,110 mm
→
1,200 mm
1,61 mm ± 80,5 Ø
3 ⊗



ZKS 819.824
068 103 384 A (10x)
M 12x1,75x115

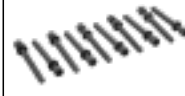

ZKHS 470.280



619.771
028 103 483 G

















915.017
028 103 533
3x

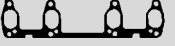

915.009
028 103 532 A
3x



			<p>a) </p> <p>b) </p>	<p>K: </p> <p>N: </p>	
<p>VAS 825.042 FPM 701.289 027 109 675 FPM 8x</p>	<p>625.760 037 253 039 D </p>	<p>915.213 028 129 717 D </p>	<p>a) 030.793 Dirko HT</p> <p>b) 567.640 N 908 132 01 M 14x1,5x22</p>	<p>K:← 155.560 038 103 085 E ASW RD PTFE/ACM 35x48x10</p> <p>K:→ 012.370 06A 103 171 A IWD LD PTFE/ACM 85</p> <p>N:← 129.780 038 103 085 C ASW RD PTFE/ACM 32x47x10</p>	<p>TLS 703.980 </p>
<p>VAS 825.042 FPM 701.289 027 109 675 FPM 8x</p>	<p>815.187 028 129 589 B 4x </p>	<p>915.213 028 129 717 D </p>	<p>a) 495.620 044 103 609 D →8D-X-260 000 </p> <p>a) 030.793 Dirko HT 8D-X-260 001→</p> <p>b) 878.070 N 906 606 01 incl. 115.100 M 14x1,5x16</p> <p>b) 115.100 N 013 849.2 CU A 14x20x1,5</p>	<p>K:← 325.155 068 103 085 E ASW WD FPM/ACM 32x47x10</p> <p>K:→ 804.850 028 103 171 K SP LD PTFE/ACM 85</p> <p>N:← 325.155 068 103 085 E ASW WD FPM/ACM 32x47x10</p>	<p>TLS 703.980 </p>

AUDI

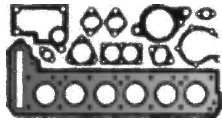



BKC
4 Cyl. **1896 ccm**
Cyl. 79,5 Ø

A3 TDI
05/2003 → 05/2010

ES⊕ **330.340**

CS* **735.690**

150.153
038 103 383 DE
 0,910 mm
→
1,000 mm
1,49 mm $\frac{+}{-}$ 80,5 Ø
1 ⊗

150.162
038 103 383 DF
 1,010 mm
→
1,100 mm
1,57 mm $\frac{+}{-}$ 80,5 Ø
2 ⊗

150.172
038 103 383 DG
 1,110 mm
→
1,200 mm
1,65 mm $\frac{+}{-}$ 80,5 Ø
3 ⊗

ZKS 057.240
038 103 384 (10x)
M 12x1,75x172

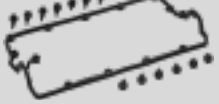
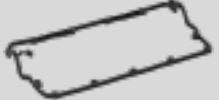

ZKHS 383.280
038 103 483 D
+038 128 773 (13x)

266.060
038 103 483 D



BKE BRB
4 Cyl. **1896 ccm**
Cyl. 79,5 Ø

A4 TDI
06/2004 → 06/2008



ES⊕ **330.340**

150.153
038 103 383 DE
 0,910 mm
→
1,000 mm
1,49 mm $\frac{+}{-}$ 80,5 Ø
1 ⊗

150.162
038 103 383 DF
 1,010 mm
→
1,100 mm
1,57 mm $\frac{+}{-}$ 80,5 Ø
2 ⊗

150.172
038 103 383 DG
 1,110 mm
→
1,200 mm
1,65 mm $\frac{+}{-}$ 80,5 Ø
3 ⊗

ZKS 057.240
038 103 384 (10x)
M 12x1,75x172



ZKHS 459.630
038 103 483 D
+022 103 831 B (13x)

266.060
038 103 483 D



BLS
4 Cyl. **1896 ccm**
Cyl. 79,5 Ø

A3 TDI
05/2003 → 05/2010

ES⊕ **548.181**

CS* **735.690**







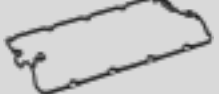









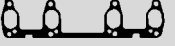

150.153
038 103 383 DE
 0,910 mm
→
1,000 mm
1,49 mm $\frac{+}{-}$ 80,5 Ø
1 ⊗

150.162
038 103 383 DF
 1,010 mm
→
1,100 mm
1,57 mm $\frac{+}{-}$ 80,5 Ø
2 ⊗

150.172
038 103 383 DG
 1,110 mm
→
1,200 mm
1,65 mm $\frac{+}{-}$ 80,5 Ø
3 ⊗

ZKS 057.240
038 103 384 (10x)
M 12x1,75x172

542.000
03G 103 483 D

			<p>a) </p> <p>b) </p>	<p>K: </p> <p>N: </p>	
<p>VAS 825.042 FPM 701.289 027 109 675 FPM 8x</p>	<p>625.760 037 253 039 D </p>	<p>915.213 028 129 717 D </p>	<p>a) 030.793 Dirko HT b) 567.640 N 908 132 01 M 14x1,5x22</p>	<p>K:← 155.560 038 103 085 E ASW RD PTFE/ACM 35x48x10 K:→ 430.190 038 103 171 S IWD LD PTFE 85 N:← 129.780 038 103 085 C ASW RD PTFE/ACM 32x47x10</p>	<p>TLS 704.040 →02/2006  TLS 722.050 03/2006→ </p>
<p>VAS 825.042 FPM 701.289 027 109 675 FPM 8x</p>	<p>625.760 037 253 039 D </p>	<p>915.213 028 129 717 D </p>	<p>a) 030.793 Dirko HT b) 567.640 N 908 132 01 M 14x1,5x22</p>	<p>K:← 155.560 038 103 085 E ASW RD PTFE/ACM 35x48x10 K:→ 012.370 06A 103 171 A IWD LD PTFE/ACM 85 N:← 129.780 038 103 085 C ASW RD PTFE/ACM 32x47x10</p>	<p>TLS 703.980 </p>
<p>VAS 825.042 FPM 701.289 027 109 675 FPM 8x</p>	<p>150.111 03G 253 039 A </p>	<p>915.213 028 129 717 D </p>	<p>a) 030.793 Dirko HT b) 567.640 N 908 132 01 M 14x1,5x22</p>	<p>K:← 155.560 038 103 085 E ASW RD PTFE/ACM 35x48x10 K:→ 430.190 038 103 171 S IWD LD PTFE 85 N:← 129.780 038 103 085 C ASW RD PTFE/ACM 32x47x10</p>	<p>TLS 196.390 </p>

AUDI

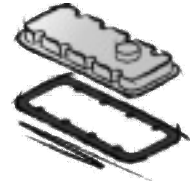
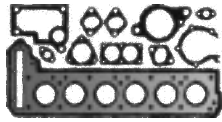

BXE
4 Cyl. **1896 ccm**
Cyl. 79,5 Ø

A3 TDI
05/2003 → 05/2010

ES⊕ **330.340**

CS* **735.690**

150.153
038 103 383 DE
 0,910 mm
→
1,000 mm
1,49 mm $\frac{\pm}{\pm}$ 80,5 Ø
1 ⊗



150.162
038 103 383 DF
 1,010 mm
→
1,100 mm
1,57 mm $\frac{\pm}{\pm}$ 80,5 Ø
2 ⊗



150.172
038 103 383 DG
 1,110 mm
→
1,200 mm
1,65 mm $\frac{\pm}{\pm}$ 80,5 Ø
3 ⊗



ZKS **057.240**
038 103 384 (10x)
M 12x1,75x172



ZKHS **383.280**
038 103 483 D
+038 128 773 (13x)



266.060
038 103 483 D

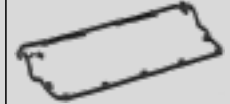

WH WN
5 Cyl. **1921 ccm**
Cyl. 79,5 Ø

100
08/1980 → 08/1984
80
09/1981 → 07/1983
Coupé
08/1980 → 07/1983

ES⊕ **307.611**
035 198 012 L
CS* **547.477**
034 198 011 C

915.629
035 103 383 J
1,80 mm $\frac{\pm}{\pm}$ 81,5 Ø



ZKS **819.883**
049 103 385 (12x)
M 11x1,5x98



ZKHS **692.751**
034 198 025 A



ZKHS **914.398**
034 198 025 D



AZV BKD
4 Cyl. **1968 ccm**
Cyl. 81,0 Ø

A3 TDI
05/2003 → 03/2013

ES⊕ **490.921**

CS* **735.690**

150.380
03G 103 383 AA
 0,910 mm
→
1,000 mm
1,55 mm $\frac{\pm}{\pm}$ 82 Ø
1 ⊗

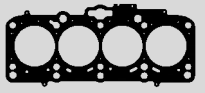

150.390
03G 103 383 AB
 1,010 mm
→
1,100 mm
1,63 mm $\frac{\pm}{\pm}$ 82 Ø
2 ⊗

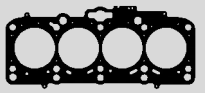

150.400
03G 103 383 AC
 1,110 mm
→
1,200 mm
1,71 mm $\frac{\pm}{\pm}$ 82 Ø
3 ⊗

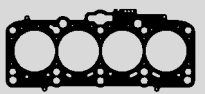

ZKS **305.430**
03G 103 384 (10x)
M 12x1,75x152





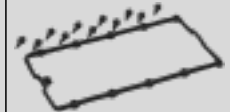













ZKHS **388.930**
03G 103 483

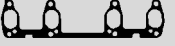

005.911
03G 103 483



461.682
EL-Liq 74
↓

			<p>a) </p> <p>b) </p>	<p>K: </p> <p>N: </p>	
<p>VAS 825.042 FPM 701.289 027 109 675 FPM 8x</p>	<p>625.760 037 253 039 D </p>	<p>915.213 028 129 717 D </p>	<p>a) 030.793 Dirko HT</p> <p>b) 567.640 N 908 132 01 M 14x1,5x22</p>	<p>K:← 155.560 038 103 085 E ASW RD PTFE/ACM 35x48x10</p> <p>K:→ 430.190 038 103 171 S IWD LD PTFE 85</p> <p>N:← 129.780 038 103 085 C ASW RD PTFE/ACM 32x47x10</p>	<p>TLS 722.050 </p>
<p>VAS 730.130 FPM 553.190 026 109 675 FPM 10x</p>	<p>815.187 028 129 589 B 5x </p>	<p>826.227 034 129 717 M </p>	<p>a) 107.256 054 103 609 </p> <p>b) 878.070 N 906 606 01 incl. 115.100 M 14x1,5x16</p> <p>b) 115.100 N 013 849.2 CU A 14x20x1,5</p>	<p>K:← 294.357 069 115 147 E ASW RD FPM/ACM 35x48x10</p> <p>K:← 475.961 054 115 147 B ASW RD FPM 35x48x10</p> <p>K:→ 342.093 068 103 051 P ASW LD FPM 85x105x11</p> <p>K:→ 804.850 028 103 171 K SP LD PTFE/ACM 85</p> <p>K:→ 829.056 068 198 171 ASW LD FPM 85x105x11</p> <p>N:← 325.155 068 103 085 E ASW WD FPM/ACM 32x47x10</p>	
<p>VAS 235.610 FPM 724.590 036 109 675 A FPM 16x</p>	<p>477.640 03G 253 039 </p>	<p>477.630 03G 129 717 D </p>	<p>a) 030.793 Dirko HT</p> <p>b) 567.640 N 908 132 01 M 14x1,5x22</p>	<p>K:← 155.560 038 103 085 E ASW RD PTFE/ACM 35x48x10</p> <p>K:→ 430.190 038 103 171 S IWD LD PTFE 85</p> <p>N:← 129.780 038 103 085 C ASW RD PTFE/ACM 32x47x10 2x</p>	<p>TLS 740.790 </p>

AUDI

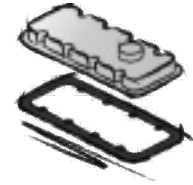
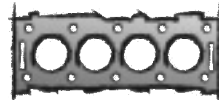
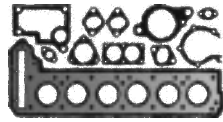

BMM
4 Cyl. **1968 ccm**
Cyl. 81,0 Ø

A3 TDI
06/2005 → 06/2008

ES⊕ **548.181**

CS* **735.690**

150.782
03G 103 383 J
 0,910 mm
→
1,000 mm
1,49 mm ± 82 Ø
1 ⊗



150.791
03G 103 383 K
 1,010 mm
→
1,100 mm
1,57 mm ± 82 Ø
2 ⊗



150.801
03G 103 383 L
 1,110 mm
→
1,200 mm
1,65 mm ± 82 Ø
3 ⊗



ZKS 057.240
038 103 384 (10x)
M 12x1,75x172



542.000
03G 103 483 D



BPW BRC
4 Cyl. **1968 ccm**
Cyl. 81,0 Ø

A4 TDI
11/2004 → 03/2009

ES⊕ **330.340**

ES⊕ **655.360**

150.782
03G 103 383 J
 0,910 mm
→
1,000 mm
1,49 mm ± 82 Ø
1 ⊗



150.791
03G 103 383 K
 1,010 mm
→
1,100 mm
1,57 mm ± 82 Ø
2 ⊗



150.801
03G 103 383 L
 1,110 mm
→
1,200 mm
1,65 mm ± 82 Ø
3 ⊗



ZKS 057.240
038 103 384 (10x)
M 12x1,75x172



ZKHS 459.630
038 103 483 D
+022 103 831 B (13x)



266.060
038 103 483 D



BLB BRD BRF BVF **BNA BRE BVA BVG**
4 Cyl. **1968 ccm**
Cyl. 81,0 Ø

A4 TDI
11/2004 → 06/2008

A6 TDI
07/2004 → 08/2011

ES⊕ **531.422**

CS* **735.690**

150.380
03G 103 383 AA
 0,910 mm
→
1,000 mm
1,55 mm ± 82 Ø
1 ⊗

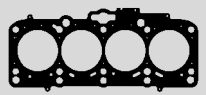

150.390
03G 103 383 AB
 1,010 mm
→
1,100 mm
1,63 mm ± 82 Ø
2 ⊗

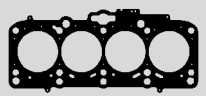

150.400
03G 103 383 AC
 1,110 mm
→
1,200 mm
1,71 mm ± 82 Ø
3 ⊗

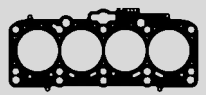

















ZKS 305.430
03G 103 384 (10x)
M 12x1,75x152



527.110
03G 103 483 B



461.682
EL-Liq 74
↓

			<p>a) </p> <p>b) </p>	<p>K: </p> <p>N: </p>	
<p>VAS 825.042 FPM 701.289 027 109 675 FPM 8x</p>	<p>150.111 03G 253 039 A</p> 	<p>915.213 028 129 717 D</p> 	<p>a) 030.793 Dirko HT</p> <p>b) 567.640 N 908 132 01 M 14x1,5x22</p>	<p>K:← 155.560 038 103 085 E ASW RD PTFE/ACM 35x48x10</p> <p>K:→ 430.190 038 103 171 S IWD LD PTFE 85</p> <p>N:← 129.780 038 103 085 C ASW RD PTFE/ACM 32x47x10</p>	<p>TLS 196.390</p> 
<p>VAS 825.042 FPM 701.289 027 109 675 FPM 8x</p>	<p>625.760 037 253 039 D</p> 	<p>915.213 028 129 717 D</p> 	<p>a) 030.793 Dirko HT</p> <p>b) 567.640 N 908 132 01 M 14x1,5x22</p>	<p>K:← 155.560 038 103 085 E ASW RD PTFE/ACM 35x48x10</p> <p>K:→ 012.370 06A 103 171 A IWD LD PTFE/ACM 85</p> <p>N:← 129.780 038 103 085 C ASW RD PTFE/ACM 32x47x10</p>	<p>TLS 703.980</p> 
<p>VAS 235.610 FPM 724.590 036 109 675 A FPM 16x</p>	<p>477.640 03G 253 039</p> 	<p>477.630 03G 129 717 D</p> 	<p>a) 030.793 Dirko HT</p> <p>b) 567.640 N 908 132 01 M 14x1,5x22</p>	<p>K:← 155.560 038 103 085 E ASW RD PTFE/ACM 35x48x10</p> <p>K:→ 430.190 038 103 171 S IWD LD PTFE 85</p> <p>N:← 129.780 038 103 085 C ASW RD PTFE/ACM 32x47x10 2x</p>	<p>TLS 703.980</p> 

AUDI



BMN BUY
4 Cyl. **1968 ccm**
Cyl. 81,0 Ø

A3 TDI
03/2006 → 03/2013

ES⊕ **747.720**
→11/2006
→8P-7-120 000



ES⊕ **542.181**
11/2006→
8P-7-120 001→



CS* **735.690**

150.380
03G 103 383 AA
0,910 mm
→
1,000 mm
1,55 mm ± 82 Ø
1 ⊗

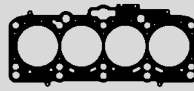

150.390
03G 103 383 AB
1,010 mm
→
1,100 mm
1,63 mm ± 82 Ø
2 ⊗

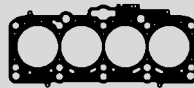

150.400
03G 103 383 AC
1,110 mm
→
1,200 mm
1,71 mm ± 82 Ø
3 ⊗

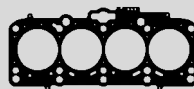

ZKS 305.430
03G 103 384 (10x)
M 12x1,75x152



717.580
03G 103 483 C

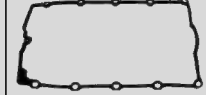

461.682
EL-Liq 74
↓

CAGA CAGB
CAGC CAHA
CAHB CMEA

4 Cyl. **1968 ccm**
Cyl. 81,0 Ø

A4 Allroad TDI
04/2009 → 05/2016

A4 TDI
11/2007 → 12/2015

A5 TDI
08/2008 → 01/2017

A6 TDI
07/2004 → 08/2011

Q5 TDI
11/2008 → 05/2017

ES⊕ **220.190**
→07/2009



ES⊕ **306.130**
08/2009→



CS* **904.780**

898.460
03L 103 383 AQ
0,910 mm
→
1,000 mm
1,55 mm ± 82 Ø
1 ⊗



898.480
03L 103 383 AR
03L 103 383 AK
1,010 mm
→
1,100 mm
1,63 mm ± 82 Ø
2 ⊗



898.510
03L 103 383 AS
03L 103 383 AL
1,110 mm
→
1,200 mm
1,71 mm ± 82 Ø
3 ⊗



ZKS 189.380
WHT 002 131 (10x)
M 9x1,75x137

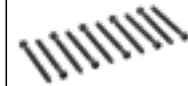

















733.460
03L 103 483



461.682
EL-Liq 74
↓

380.150
04L 103 070 B
(03L 103 469 C/R/S/T)
4x

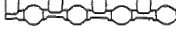

			<p>a) </p> <p>b) </p>	<p>K: </p> <p>N: </p>	
<p>VAS 235.610 FPM 724.590 036 109 675 A FPM 16x</p>	<p>733.350 03G 253 039 E </p>	<p>477.630 03G 129 717 D →11/2006 →8P-7-120 000 </p> <p>493.390 03G 129 717 C 11/2006→ 8P-7-120 001→ </p>	<p>a) 030.793 Dirko HT</p> <p>b) 567.640 N 908 132 01 M 14x1,5x22</p>	<p>K:← 155.560 038 103 085 E ASW RD PTFE/ACM 35x48x10</p> <p>K:→ 430.190 038 103 171 S IWD LD PTFE 85</p> <p>N:← 129.780 038 103 085 C ASW RD PTFE/ACM 32x47x10 2x</p>	<p>TLS 332.380 </p>
<p>VAS 235.610 FPM 724.590 036 109 675 A FPM 16x</p>	<p>477.640 03G 253 039 </p>	<p>736.650 03L 129 717 →07/2009 </p> <p>246.150 03L 129 717 B 08/2009→ </p>	<p>a) 030.793 Dirko HT</p> <p>b) 567.640 N 908 132 01 M 14x1,5x22</p>	<p>K:← 155.560 038 103 085 E ASW RD PTFE/ACM 35x48x10</p> <p>K:→ 364.700 03L 103 171 IWD LD PTFE/ACM 85</p> <p>N:← 897.690 03L 103 085 AW RD PTFE/ACM 32x47x10</p>	<p>TLS 226.510 </p>

AUDI

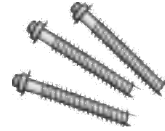
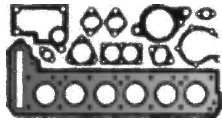

CBA **CBAB**
BBB **CBEA**

4 Cyl. **1968 ccm**
Cyl. 81,0 Ø

A3
01/2010 → 03/2013

A3 TDI
05/2003 → 05/2013

TT TDI
06/2008 → 06/2014

ES⊕ **220.190**
→07/2009

ES⊕ **306.130**
08/2009→

CS* **904.780**



898.460
03L 103 383 AQ
0,910 mm
→
1,000 mm
1,55 mm $\frac{1}{2}$ 82 Ø
1 ⊗



898.480
03L 103 383 AR
03L 103 383 AK
1,010 mm
→
1,100 mm
1,63 mm $\frac{1}{2}$ 82 Ø
2 ⊗

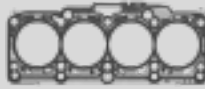

898.510
03L 103 383 AS
03L 103 383 AL
1,110 mm
→
1,200 mm
1,71 mm $\frac{1}{2}$ 82 Ø
3 ⊗



ZKS 189.380
WHT 002 131 (10x)
M 9x1,75x137



733.460
03L 103 483

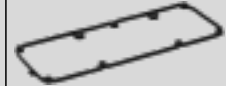

461.682
EL-Liq 74
↓
380.150
04L 103 070 B
(03L 103 469 C/R/S/T)
4x



CFFA **CFFB**
CFGB **CFHB**
CFHD **CLJA**

4 Cyl. **1968 ccm**
Cyl. 81,0 Ø

A1 TDI
09/2011 → 04/2015

A3 TDI
05/2003 → 05/2013

Q3 TDI
09/2011 → 10/2018

TT TDI
06/2008 → 06/2014

ES⊕ **236.340**

CS* **236.040**

OXS **235.900**
03L 198 070



726.740
03L 130 383 BM
0,910 mm
→
1,000 mm
1,55 mm $\frac{1}{2}$ 82,2 Ø
1 ⊗



726.840
03L 130 383 BN
1,010 mm
→
1,100 mm
1,63 mm $\frac{1}{2}$ 82,2 Ø
2 ⊗



726.850
03L 130 383 BP
1,110 mm
→
1,200 mm
1,71 mm $\frac{1}{2}$ 82,2 Ø
3 ⊗



ZKS 189.380
WHT 002 131 (10x)
M 9x1,75x137



ZKHS 380.440
(03L 103 469 C/R)

















898.600
03L 103 483 C
(03L 103 469 C/R)



461.682
EL-Liq 74
↓
380.150
04L 103 070 B
(03L 103 469 C/R/S/T)
4x

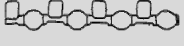

860.130
03L 103 487
2x

			<p>a) </p> <p>b) </p>	<p>K: </p> <p>N: </p>	
<p>VAS 235.610 FPM 724.590 036 109 675 A FPM 16x</p>	<p>477.640 03G 253 039 </p>	<p>736.650 03L 129 717 →07/2009  246.150 03L 129 717 B 08/2009→ </p>	<p>a) 030.793 Dirko HT b) 567.640 N 908 132 01 M 14x1,5x22</p>	<p>K:← 155.560 038 103 085 E ASW RD PTFE/ACM 35x48x10 K:→ 364.700 03L 103 171 IWD LD PTFE/ACM 85 N:← 897.690 03L 103 085 AW RD PTFE/ACM 32x47x10</p>	<p>TLS 303.100 </p>
<p>VAS 235.610 FPM 724.590 036 109 675 A FPM 16x</p>	<p>007.870 03L 253 039 E </p>	<p>236.320 03L 129 717 E </p>	<p>a) 030.793 Dirko HT b) 567.640 N 908 132 01 M 14x1,5x22</p>	<p>K:← 155.560 038 103 085 E ASW RD PTFE/ACM 35x48x10 K:→ 364.700 03L 103 171 IWD LD PTFE/ACM 85 N:← 897.690 03L 103 085 AW RD PTFE/ACM 32x47x10</p>	<p>TLS 262.500 </p>

AUDI

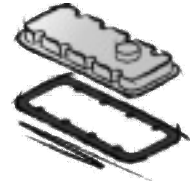
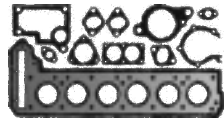

CFGD
CLLB

4 Cyl. **1968 ccm**
Cyl. 81,0 Ø

Q3 TDI
06/2011 → 10/2018

ES⊕ **387.500**

CS* **236.040**
OKS **235.900**
03L 198 070

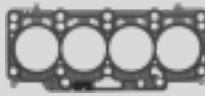

726.740
03L 130 383 BM
 0,910 mm
→
1,000 mm
1,55 mm $\frac{3}{4}$ 82,2 Ø
1 ⊗

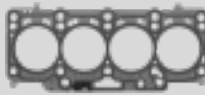

726.840
03L 130 383 BN
 1,010 mm
→
1,100 mm
1,63 mm $\frac{3}{4}$ 82,2 Ø
2 ⊗



726.850
03L 130 383 BP
 1,110 mm
→
1,200 mm
1,71 mm $\frac{3}{4}$ 82,2 Ø
3 ⊗

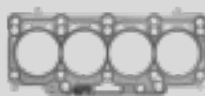

ZKS 189.380
WHT 002 131 (10x)
M 9x1,75x137



ZKHS 380.440
(03L 103 469 C/R)



898.600
03L 103 483 C
(03L 103 469 C/R)

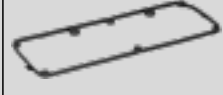

461.682
EL-Liq 74



380.150
04L 103 070 B
(03L 103 469 C/R/S/T)
4x



860.130
03L 103 487
2x

CGLC
CGLD

4 Cyl. **1968 ccm**
Cyl. 81,0 Ø

A4 Allroad TDI
04/2009 → 05/2016

A4 TDI
08/2008 → 12/2015

A5 TDI
08/2008 → 01/2017

A6 TDI
03/2011 → 09/2018

Q5 TDI
11/2008 → 05/2017

ES⊕ **588.450**

CS* **236.040**
OKS **235.900**
03L 198 070



726.740
03L 130 383 BM
 0,910 mm
→
1,000 mm
1,55 mm $\frac{3}{4}$ 82,2 Ø
1 ⊗



726.840
03L 130 383 BN
 1,010 mm
→
1,100 mm
1,63 mm $\frac{3}{4}$ 82,2 Ø
2 ⊗



726.850
03L 130 383 BP
 1,110 mm
→
1,200 mm
1,71 mm $\frac{3}{4}$ 82,2 Ø
3 ⊗



ZKS 189.380
WHT 002 131 (10x)
M 9x1,75x137



ZKHS 380.440
(03L 103 469 C/R)



898.600
03L 103 483 C
(03L 103 469 C/R)

















461.682
EL-Liq 74



380.150
04L 103 070 B
(03L 103 469 C/R/S/T)
4x



860.130
03L 103 487
2x

			<p>a) </p> <p>b) </p>	<p>K: </p> <p>N: </p>	
<p>VAS 235.610 FPM 724.590 036 109 675 A FPM 16x</p>	<p>328.170 04L 253 039 D </p>	<p>236.320 03L 129 717 E </p>	<p>a) 030.793 Dirko HT b) 567.640 N 908 132 01 M 14x1,5x22</p>	<p>K:← 155.560 038 103 085 E ASW RD PTFE/ACM 35x48x10 K:→ 364.700 03L 103 171 IWD LD PTFE/ACM 85 N:← 897.690 03L 103 085 AW RD PTFE/ACM 32x47x10</p>	<p>TLS 328.180 </p>
<p>VAS 235.610 FPM 724.590 036 109 675 A FPM 16x</p>	<p>328.170 04L 253 039 D </p>	<p>236.320 03L 129 717 E </p>	<p>a) 030.793 Dirko HT b) 567.640 N 908 132 01 M 14x1,5x22</p>	<p>K:← 155.560 038 103 085 E ASW RD PTFE/ACM 35x48x10 K:→ 364.700 03L 103 171 IWD LD PTFE/ACM 85 N:← 897.690 03L 103 085 AW RD PTFE/ACM 32x47x10</p>	<p>TLS 588.880 </p>

AUDI

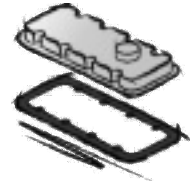
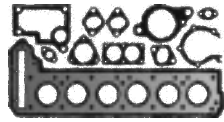

CGLA **CGLB**
CGLE **CJCA**
CJCB **CJCC**
CJCD **CMFA**
CMFB **CMGA**
CMGB

4 Cyl. **1968 ccm**
 Cyl. 81,0 Ø

A4 Allroad TDI
 09/2009 → 05/2016
A4 TDI
 11/2007 → 12/2015
A5 TDI
 09/2009 → 01/2017
A6 TDI
 03/2011 → 09/2018
Q5 TDI
 11/2008 → 05/2017

ES⊕ **236.340**

 CS* **236.040**
 OKS **235.900**
 03L 198 070

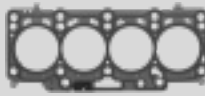

726.740
 03L 130 383 BM
 0,910 mm
 →
 1,000 mm
 1,55 mm $\frac{3}{8}$ 82,2 Ø
 1 ⊗

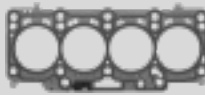

726.840
 03L 130 383 BN
 1,010 mm
 →
 1,100 mm
 1,63 mm $\frac{3}{8}$ 82,2 Ø
 2 ⊗



726.850
 03L 130 383 BP
 1,110 mm
 →
 1,200 mm
 1,71 mm $\frac{3}{8}$ 82,2 Ø
 3 ⊗

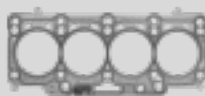

ZKS 189.380
 WHT 002 131 (10x)
 M 9x1,75x137



ZKHS 380.440
 (03L 103 469 C/R)



898.600
 03L 103 483 C
 (03L 103 469 C/R)

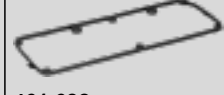

461.682
 EL-Liq 74

↓

380.150
 04L 103 070 B
 (03L 103 469 C/R/S/T)
 4x





860.130
 03L 103 487
 2x

CNHA
CNHG

4 Cyl. **1968 ccm**
 Cyl. 81,0 Ø

A4 Allroad TDI
 04/2009 → 05/2016
A4 TDI
 08/2008 → 12/2015
A5 TDI
 08/2008 → 01/2017
A6 TDI
 11/2013 → 09/2018
Q5 TDI
 11/2008 → 05/2017

ES⊕ **467.840**
 A4 8K2/8K5
 A5 8T3/8F7

 ES⊕ **468.210**

 CS* **452.990**
 OKS **482.140**
 03N 198 070



593.930
 04L 103 383 BJ
 0,910 mm
 →
 1,000 mm
 1,55 mm $\frac{3}{8}$
 1 ⊗



593.940
 04L 103 383 BK
 1,010 mm
 →
 1,100 mm
 1,63 mm $\frac{3}{8}$
 2 ⊗



593.950
 04L 103 383 BL
 1,110 mm
 →
 1,200 mm
 1,71 mm $\frac{3}{8}$
 3 ⊗



ZKS 351.900
 WHT 005 673 (10x)
 M12x1,75x206



ZKHS 982.110
 (03L 103 469 S/T)

330.200
 03L 103 483 S
 (03L 103 469 S/T)

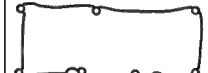













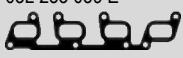

461.682
 EL-Liq 74

↓

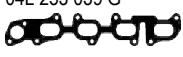
380.150
 04L 103 070 B
 (03L 103 469 C/R/S/T)
 4x



			<p>a) </p> <p>b) </p>	<p>K: </p> <p>N: </p>	
<p>VAS 235.610 FPM 724.590 036 109 675 A FPM 16x</p>	<p>007.870 03L 253 039 E </p>	<p>236.320 03L 129 717 E </p>	<p>a) 030.793 Dirko HT</p> <p>b) 567.640 N 908 132 01 M 14x1,5x22</p>	<p>K:← 155.560 038 103 085 E ASW RD PTFE/ACM 35x48x10</p> <p>K:→ 364.700 03L 103 171 IWD LD PTFE/ACM 85</p> <p>N:← 897.690 03L 103 085 AW RD PTFE/ACM 32x47x10</p>	<p>TLS 588.880 </p>
<p>VAS 235.610 FPM 724.590 036 109 675 A FPM 16x</p>	<p>902.561 04L 253 039 G </p>	<p>352.810 04L 129 717 D A4 8K2/8K5 A5 8T3/8F7 </p> <p>796.400 04L 129 717 F </p>	<p>a) 030.793 Dirko HT</p> <p>b) 567.640 N 908 132 01 M 14x1,5x22</p>	<p>K:← 340.290 04L 103 151 SP RD PTFE 35</p> <p>K:→ 340.280 04L 103 171 IWD LD PTFE 85</p> <p>N:← 897.690 03L 103 085 AW RD PTFE/ACM 32x47x10</p>	<p>TLS 696.000 </p>

AUDI



**CRFA
CRFC**

4 Cyl. **1968 ccm**
Cyl. 81,0 ∅

A3 TDI
09/2012 → 10/2020
Q2 TDI
11/2016 → 10/2020

ES⊕ **391.000**

CS* **452.990**
OKS **482.140**
03N 198 070



593.930
04L 103 383 BJ
 0,910 mm
→ 1,000 mm
1,55 mm ±
1 ⊗



593.940
04L 103 383 BK
 1,010 mm
→ 1,100 mm
1,63 mm ±
2 ⊗



593.950
04L 103 383 BL
 1,110 mm
→ 1,200 mm
1,71 mm ±
3 ⊗



ZKS 351.900
WHT 005 673 (10x)
M12x1,75x206



ZKHS 982.100
(04L 103 469 A/P/S)
ZKHS 982.110
(03L 103 469 S/T)
330.200
03L 103 483 S
(03L 103 469 S/T)

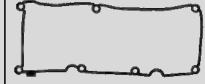

374.000
04L 103 483
(04L 103 469 A/P/S)



461.682
EL-Liq 74
↓

380.150
04L 103 070 B
(03L 103 469 C/R/S/T)
4x





811.540
04L 103 070 A
(04L 103 469 A/P/S)
4x

**CSUA
CSUB**

4 Cyl. **1968 ccm**
Cyl. 81,0 ∅

A4 Allroad TDI
09/2009 → 05/2016
A4 TDI
11/2007 → 12/2015
A5 TDI
09/2009 → 01/2017
Q5 TDI
08/2009 → 05/2017

ES⊕ **468.050**
A4 8K2/8K5
A5 8T3/8F7

ES⊕ **468.060**
Q5

CS* **452.990**
OKS **482.140**
03N 198 070



593.930
04L 103 383 BJ
 0,910 mm
→ 1,000 mm
1,55 mm ±
1 ⊗



593.940
04L 103 383 BK
 1,010 mm
→ 1,100 mm
1,63 mm ±
2 ⊗



593.950
04L 103 383 BL
 1,110 mm
→ 1,200 mm
1,71 mm ±
3 ⊗



ZKS 351.900
WHT 005 673 (10x)
M12x1,75x206



ZKHS 982.100
(04L 103 469 A/P/S)
ZKHS 982.110
(03L 103 469 S/T)
330.200
03L 103 483 S
(03L 103 469 S/T)



374.000
04L 103 483
(04L 103 469 A/P/S)

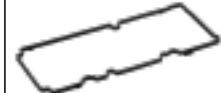













461.682
EL-Liq 74
↓

380.150
04L 103 070 B
(03L 103 469 C/R/S/T)
4x



811.540
04L 103 070 A
(04L 103 469 A/P/S)
4x

			<p>a) </p> <p>b) </p>	<p>K: </p> <p>N: </p>	
<p>VAS 235.610 FPM 724.590 036 109 675 A FPM 16x</p>	<p>328.170 04L 253 039 D </p>	<p>352.810 04L 129 717 D </p>	<p>a) 030.793 Dirko HT b) 567.640 N 908 132 01 M 14x1,5x22</p>	<p>K:← 340.290 04L 103 151 SP RD PTFE 35 K:→ 340.280 04L 103 171 IWD LD PTFE 85 N:← 897.690 03L 103 085 AW RD PTFE/ACM 32x47x10</p>	<p>TLS 388.780</p>
<p>VAS 235.610 FPM 724.590 036 109 675 A FPM 16x</p>	<p>729.571 04L 253 039 B </p>	<p>352.810 04L 129 717 D A4 8K2/8K5 A5 8T3/8F7  796.400 04L 129 717 F Q5 </p>	<p>a) 030.793 Dirko HT b) 567.640 N 908 132 01 M 14x1,5x22</p>	<p>K:← 340.290 04L 103 151 SP RD PTFE 35 K:→ 340.280 04L 103 171 IWD LD PTFE 85 N:← 897.690 03L 103 085 AW RD PTFE/ACM 32x47x10</p>	<p>TLS 695.560</p>

AUDI

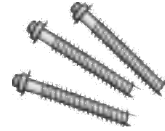
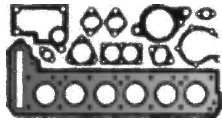



**CSUD
CSUE**

4 Cyl. **1968 ccm**
Cyl. 81,0 Ø

A6 TDI
01/2012 → 09/2018

ES⊕ **468.060**

CS* **452.990**
OKS **482.140**
03N 198 070





593.930
04L 103 383 BJ
 0,910 mm
→ 1,000 mm
1,55 mm ±
1 ⊗



593.940
04L 103 383 BK
 1,010 mm
→ 1,100 mm
1,63 mm ±
2 ⊗



593.950
04L 103 383 BL
 1,110 mm
→ 1,200 mm
1,71 mm ±
3 ⊗



ZKS 351.900
WHT 005 673 (10x)
M12x1,75x206



ZKHS 982.100
(04L 103 469 A/P/S)
ZKHS 982.110
(03L 103 469 S/T)
330.200
03L 103 483 S
(03L 103 469 S/T)

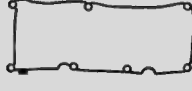

374.000
04L 103 483
(04L 103 469 A/P/S)



461.682
EL-Liq 74
↓
380.150
04L 103 070 B
(03L 103 469 C/R/S/T)
4x

811.540
04L 103 070 A
(04L 103 469 A/P/S)
4x

**CRBC CRBD
CRLB CRLC
CRUA CUVB
CUVC CUVD
DBBA DCYA
DEJA DEJB
DFGA DFTA
DFTB DFTC**

4 Cyl. **1968 ccm**
Cyl. 81,0 Ø

A3 TDI
04/2012 →
Q2 TDI
09/2016 →
Q3 TDI
09/2011 →

ES⊕ **576.280**

CS* **452.990**
OKS **482.140**
03N 198 070



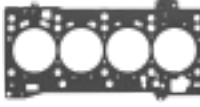

593.930
04L 103 383 BJ
 0,910 mm
→ 1,000 mm
1,55 mm ±
1 ⊗



593.940
04L 103 383 BK
 1,010 mm
→ 1,100 mm
1,63 mm ±
2 ⊗



593.950
04L 103 383 BL
 1,110 mm
→ 1,200 mm
1,71 mm ±
3 ⊗



ZKS 351.900
WHT 005 673 (10x)
M12x1,75x206





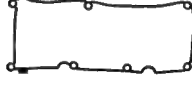











ZKHS 982.100
(04L 103 469 A/P/S)
ZKHS 982.110
(03L 103 469 S/T)
330.200
03L 103 483 S
(03L 103 469 S/T)



374.000
04L 103 483
(04L 103 469 A/P/S)



461.682
EL-Liq 74
↓
380.150
04L 103 070 B
(03L 103 469 C/R/S/T)
4x

811.540
04L 103 070 A
(04L 103 469 A/P/S)
4x

			<p>a) </p> <p>b) </p>	<p>K: </p> <p>N: </p>	
<p>VAS 235.610 FPM 724.590 036 109 675 A FPM 16x</p>	<p>902.561 04L 253 039 G </p>	<p>796.400 04L 129 717 F </p>	<p>a) 030.793 Dirko HT</p> <p>b) 567.640 N 908 132 01 M 14x1,5x22</p>	<p>K:← 340.290 04L 103 151 SP RD PTFE 35</p> <p>K:→ 340.280 04L 103 171 IWD LD PTFE 85</p> <p>N:← 897.690 03L 103 085 AW RD PTFE/ACM 32x47x10</p>	<p>TLS 695.560</p>
<p>VAS 235.610 FPM 724.590 036 109 675 A FPM 16x</p>	<p>729.571 04L 253 039 B </p>	<p>352.810 04L 129 717 D </p>	<p>a) 030.793 Dirko HT</p> <p>b) 567.640 N 908 132 01 M 14x1,5x22</p>	<p>K:← 340.290 04L 103 151 SP RD PTFE 35</p> <p>K:→ 340.280 04L 103 171 IWD LD PTFE 85</p> <p>N:← 897.690 03L 103 085 AW RD PTFE/ACM 32x47x10</p>	<p>TLS 570.870</p> 

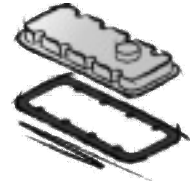
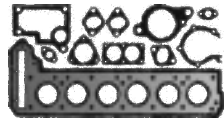
AUDI



DDCA
DDCB
4 Cyl. **1968 ccm**
Cyl. 81,0 Ø

A6 TDI
01/2012 → 09/2018

ES⊕ **479.600**

CS* **452.990**
OKS **482.140**
03N 198 070



593.930
04L 103 383 BJ
 0,910 mm
→ 1,000 mm
1,55 mm $\frac{\pm}{\text{mm}}$
1 ⊗



593.940
04L 103 383 BK
 1,010 mm
→ 1,100 mm
1,63 mm $\frac{\pm}{\text{mm}}$
2 ⊗



593.950
04L 103 383 BL
 1,110 mm
→ 1,200 mm
1,71 mm $\frac{\pm}{\text{mm}}$
3 ⊗



ZKS 351.900
WHT 005 673 (10x)
M12x1,75x206



ZKHS 982.100
(04L 103 469 A/P/S)
ZKHS 982.110
(03L 103 469 S/T)

330.200
03L 103 483 S
(03L 103 469 S/T)

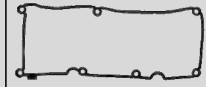

374.000
04L 103 483
(04L 103 469 A/P/S)



461.682
EL-Liq 74

↓

380.150
04L 103 070 B
(03L 103 469 C/R/S/T)
4x



811.540
04L 103 070 A
(04L 103 469 A/P/S)
4x

CZJA
DDDA
4 Cyl. **1968 ccm**
Cyl. 81,0 Ø

A6 TDI
11/2013 → 09/2018

ES⊕ **480.000**

CS* **452.990**
OKS **482.140**
03N 198 070



593.930
04L 103 383 BJ
 0,910 mm
→ 1,000 mm
1,55 mm $\frac{\pm}{\text{mm}}$
1 ⊗



593.940
04L 103 383 BK
 1,010 mm
→ 1,100 mm
1,63 mm $\frac{\pm}{\text{mm}}$
2 ⊗



593.950
04L 103 383 BL
 1,110 mm
→ 1,200 mm
1,71 mm $\frac{\pm}{\text{mm}}$
3 ⊗



ZKS 351.900
WHT 005 673 (10x)
M12x1,75x206



ZKHS 982.110
(03L 103 469 S/T)
330.200
03L 103 483 S
(03L 103 469 S/T)

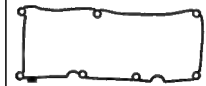













461.682
EL-Liq 74

↓

380.150
04L 103 070 B
(03L 103 469 C/R/S/T)
4x



			<p>a) </p> <p>b) </p>	<p>K: </p> <p>N: </p>	
<p>VAS 235.610 FPM 724.590 036 109 675 A FPM 16x</p>	<p>902.561 04L 253 039 G </p>	<p>796.400 04L 129 717 F </p>	<p>a) 030.793 Dirko HT</p> <p>b) 567.640 N 908 132 01 M 14x1,5x22</p>	<p>K:← 340.290 04L 103 151 SP RD PTFE 35</p> <p>K:→ 340.280 04L 103 171 IWD LD PTFE 85</p> <p>N:← 897.690 03L 103 085 AW RD PTFE/ACM 32x47x10</p>	<p>TLS 695.560</p>
<p>VAS 235.610 FPM 724.590 036 109 675 A FPM 16x</p>	<p>902.561 04L 253 039 G </p>	<p>796.400 04L 129 717 F </p>	<p>a) 030.793 Dirko HT</p> <p>b) 567.640 N 908 132 01 M 14x1,5x22</p>	<p>K:← 340.290 04L 103 151 SP RD PTFE 35</p> <p>K:→ 340.280 04L 103 171 IWD LD PTFE 85</p> <p>N:← 897.690 03L 103 085 AW RD PTFE/ACM 32x47x10</p>	<p>TLS 696.000 </p>

AUDI

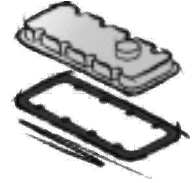
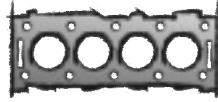
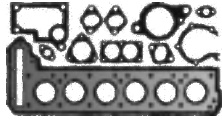

DESA DETA
DETB

4 Cyl. **1968 ccm**
Cyl. 81,0 Ø

A4 Allroad TDI

01/2016 →

A4 TDI

05/2015 →

A5 TDI

06/2016 →

A6 TDI

02/2019 →

Q5 TDI

06/2016 →

CS* **452.990**
OKS **482.140**
03N 198 070



593.930

04L 103 383 BJ

0,910 mm

→

1,000 mm

1,55 mm ±

1 ⊗

593.940

04L 103 383 BK

1,010 mm

→

1,100 mm

1,63 mm ±

2 ⊗

593.950

04L 103 383 BL

1,110 mm

→

1,200 mm

1,71 mm ±

3 ⊗

ZKS **351.900**

WHT 005 673 (10x)

M12x1,75x206



ZKHS **982.110**

(03L 103 469 S/T)

330.200

03L 103 483 S

(03L 103 469 S/T)

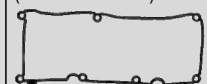

461.682

EL-Liq 74

↓

380.150

04L 103 070 B

(03L 103 469 C/R/S/T)

4x



CZHA DEUA
DEUB DEUC

4 Cyl. **1968 ccm**
Cyl. 81,0 Ø

A4 Allroad TDI

11/2016 → 10/2019

A4 TDI

05/2015 → 11/2019

A5 TDI

01/2017 → 02/2020

Q5 TDI

01/2017 → 11/2020

CS* **452.990**
OKS **482.140**
03N 198 070



593.930

04L 103 383 BJ

0,910 mm

→

1,000 mm

1,55 mm ±

1 ⊗

593.940

04L 103 383 BK

1,010 mm

→

1,100 mm

1,63 mm ±

2 ⊗

593.950

04L 103 383 BL

1,110 mm

→

1,200 mm

1,71 mm ±

3 ⊗

ZKS **351.900**

WHT 005 673 (10x)

M12x1,75x206



ZKHS **982.110**

(03L 103 469 S/T)

330.200

03L 103 483 S

(03L 103 469 S/T)

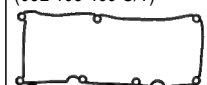

461.682

EL-Liq 74

↓

380.150

04L 103 070 B

(03L 103 469 C/R/S/T)

4x



DEZD DEZE

4 Cyl. **1968 ccm**
Cyl. 81,0 Ø

A4 TDI

03/2019 →

A5 TDI

10/2019 →

A6 TDI

03/2019 →

Q5 TDI

09/2019 → 11/2020

252.960
05L 103 383 AJ
1,55 mm ± 82,3 Ø
1 ⊗

252.970

05L 103 383 AK

1,63 mm ± 82,3 Ø

2 ⊗

252.980

05L 103 383 AL

1,71 mm ± 82,3 Ø

3 ⊗

ZKS **864.450**

WHT 007 433 (10x)

M 12x1,75x209



ZKHS **094.190**

786.220

05L 103 483 F

461.682

EL-Liq 74













↓





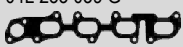
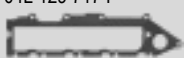





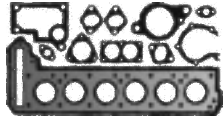
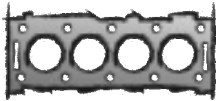

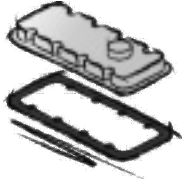
811.540

04L 103 070 A





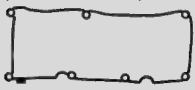







(04L 103 469 A/P/S)

4x

			<p>a) </p> <p>b) </p>	<p>K: </p> <p>N: </p>	
<p>VAS 235.610 FPM 724.590 036 109 675 A FPM 16x</p>	<p>902.561 04L 253 039 G </p>	<p>796.400 04L 129 717 F </p>	<p>a) 030.793 Dirko HT b) 567.640 N 908 132 01 M 14x1,5x22</p>	<p>K:← 340.290 04L 103 151 SP RD PTFE 35 K:→ 340.280 04L 103 171 IWD LD PTFE 85 N:← 897.690 03L 103 085 AW RD PTFE/ACM 32x47x10</p>	<p>TLS 696.000 </p>
<p>VAS 235.610 FPM 724.590 036 109 675 A FPM 16x</p>	<p>729.571 04L 253 039 B </p>	<p>796.400 04L 129 717 F </p>	<p>a) 030.793 Dirko HT b) 567.640 N 908 132 01 M 14x1,5x22</p>	<p>K:← 340.290 04L 103 151 SP RD PTFE 35 K:→ 340.280 04L 103 171 IWD LD PTFE 85 N:← 897.690 03L 103 085 AW RD PTFE/ACM 32x47x10</p>	<p>TLS 695.560</p>
<p>843.040 04E 109 675 L FPM 16x</p>	<p>786.270 05L 253 039 C</p>	<p>649.910 05L 129 717 </p>	<p>a) 030.793 Dirko HT a) 860.780 05L 103 609 A b) 567.640 N 908 132 01 M 14x1,5x22</p>	<p>N:← 786.230 05L 103 085 C AW RD PTFE/ACM 26x41x8</p>	<p>TLS 036.940</p>

AUDI 				
DEZB DEZF 4 Cyl. 1968 ccm Cyl. 81,0 Ø A4 TDI 07/2019 → A5 TDI 07/2018 → A6 TDI 01/2019 → Q5 TDI 01/2019 →		252.740 05L 103 383 AC 1,55 mm $\frac{\pm}{\pm}$ 82 Ø 1 ⊗ 252.750 05L 103 383 AD 1,63 mm $\frac{\pm}{\pm}$ 82 Ø 2 ⊗ 252.760 05L 103 383 AE 1,71 mm $\frac{\pm}{\pm}$ 82 Ø 3 ⊗	ZKS 864.450 WHT 007 433 (10x) M 12x1,75x209 	ZKHS 094.190 786.220 05L 103 483 F 461.682 EL-Liq 74 ↓ 811.540 04L 103 070 A (04L 103 469 A/P/S) 4x
DFBA 4 Cyl. 1968 ccm Cyl. 81,0 Ø A6 TDI 05/2018 → A7 TDI 09/2018 → Q5 TDI 11/2019 → 11/2020		252.960 05L 103 383 AJ 1,55 mm $\frac{\pm}{\pm}$ 82,3 Ø 1 ⊗ 252.970 05L 103 383 AK 1,63 mm $\frac{\pm}{\pm}$ 82,3 Ø 2 ⊗ 252.980 05L 103 383 AL 1,71 mm $\frac{\pm}{\pm}$ 82,3 Ø 3 ⊗	ZKS 864.450 WHT 007 433 (10x) M 12x1,75x209 	
CUNA CUPA CUWA CYLA DBGA DFHA DFUA 4 Cyl. 1968 ccm Cyl. 81,0 Ø A3 TDI 04/2012 → Q2 TDI 07/2016 → 08/2018 Q3 TDI 11/2014 → TT TDI 07/2014 →	ES⊕ 784.530  CS* 452.990 OKS 482.140 03N 198 070 	593.930 04L 103 383 BJ  0,910 mm → 1,000 mm 1,55 mm $\frac{\pm}{\pm}$ 1 ⊗ 593.940 04L 103 383 BK  1,010 mm → 1,100 mm 1,63 mm $\frac{\pm}{\pm}$ 2 ⊗ 593.950 04L 103 383 BL  1,110 mm → 1,200 mm 1,71 mm $\frac{\pm}{\pm}$ 3 ⊗	ZKS 351.900 WHT 005 673 (10x) M12x1,75x206 	ZKHS 982.100 (04L 103 469 A/P/S) ZKHS 982.110 (03L 103 469 S/T) 330.200 03L 103 483 S (03L 103 469 S/T)  374.000 04L 103 483 (04L 103 469 A/P/S)  461.682 EL-Liq 74 ↓ 380.150 04L 103 070 B (03L 103 469 C/R/S/T) 4x  811.540 04L 103 070 A (04L 103 469 A/P/S) 4x

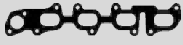
AUDI

			<p>a) </p> <p>b) </p>	<p>K: </p> <p>N: </p>	
<p>843.040 04E 109 675 L FPM 16x</p>	<p>786.270 05L 253 039 C</p>	<p>649.910 05L 129 717</p> 	<p>a) 030.793 Dirko HT</p> <p>a) 860.780 05L 103 609 A</p> <p>b) 567.640 N 908 132 01 M 14x1,5x22</p>	<p>N:← 786.230 05L 103 085 C AW RD PTFE/ACM 26x41x8</p>	<p>TLS 036.940</p>
<p>843.040 04E 109 675 L FPM 16x</p>	<p>786.290 05L 253 039 E</p>	<p>649.910 05L 129 717</p> 	<p>a) 030.793 Dirko HT</p> <p>↑</p> <p>a) 860.780 05L 103 609 A</p>	<p>N:← 786.230 05L 103 085 C AW RD PTFE/ACM 26x41x8</p>	<p>TLS 036.980</p>
<p>VAS 235.610 FPM</p> <p>724.590 036 109 675 A FPM 16x</p>	<p>902.561 04L 253 039 G</p> 	<p>352.810 04L 129 717 D</p> 	<p>a) 030.793 Dirko HT</p> <p>b) 567.640 N 908 132 01 M 14x1,5x22</p>	<p>K:← 340.290 04L 103 151 SP RD PTFE 35</p> <p>K:→ 340.280 04L 103 171 IWD LD PTFE 85</p> <p>N:← 897.690 03L 103 085 AW RD PTFE/ACM 32x47x10</p>	<p>TLS 696.000</p> 

AUDI

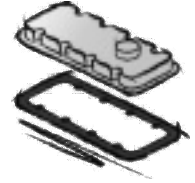
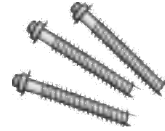
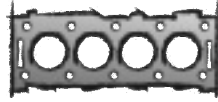
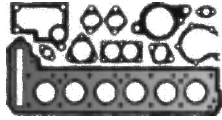

DFVA
4 Cyl. **1968 ccm**
Cyl. 81,0 Ø
A4 Allroad TDI
01/2016 →
A4 TDI
05/2015 →

CS* **452.990**

593.930
04L 103 383 BJ
0,910 mm →
1,000 mm
1,55 mm ±
1 ⊗



593.940
04L 103 383 BK
1,010 mm →
1,100 mm
1,63 mm ±
2 ⊗



593.950
04L 103 383 BL
1,110 mm →
1,200 mm
1,71 mm ±
3 ⊗



ZKS 351.900
WHT 005 673 (10x)
M12x1,75x206



ZKHS 982.100
(04L 103 469 A/P/S)
ZKHS 982.110
(03L 103 469 S/T)
330.200
03L 103 483 S
(03L 103 469 S/T)

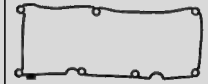

374.000
04L 103 483
(04L 103 469 A/P/S)



461.682
EL-Liq 74
↓

380.150
04L 103 070 B
(03L 103 469 C/R/S/T)
4x



811.540
04L 103 070 A
(04L 103 469 A/P/S)
4x

DGCA
4 Cyl. **1968 ccm**
Cyl. 81,0 Ø
A3 TDI
12/2012 →

ES⊕ **576.280**



CS* **452.990**
OKS **482.140**
03N 198 070



593.930
04L 103 383 BJ
0,910 mm →
1,000 mm
1,55 mm ±
1 ⊗



593.940
04L 103 383 BK
1,010 mm →
1,100 mm
1,63 mm ±
2 ⊗



593.950
04L 103 383 BL
1,110 mm →
1,200 mm
1,71 mm ±
3 ⊗



ZKS 351.900
WHT 005 673 (10x)
M12x1,75x206



ZKHS 982.100
(04L 103 469 A/P/S)
ZKHS 982.110
(03L 103 469 S/T)
330.200
03L 103 483 S
(03L 103 469 S/T)

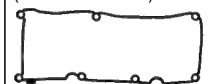

374.000
04L 103 483
(04L 103 469 A/P/S)

















461.682
EL-Liq 74
↓











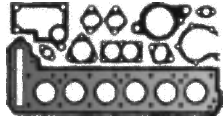
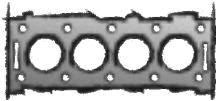

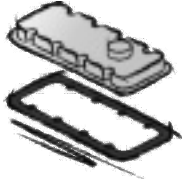
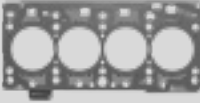
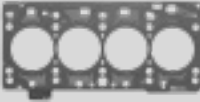
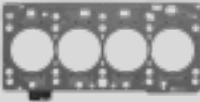

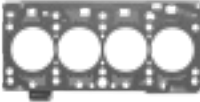
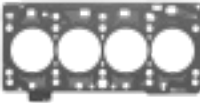
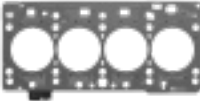
380.150
04L 103 070 B
(03L 103 469 C/R/S/T)
4x













811.540
04L 103 070 A
(04L 103 469 A/P/S)
4x











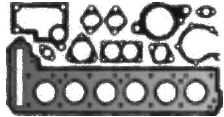
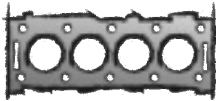

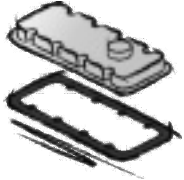
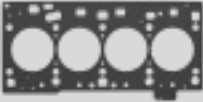
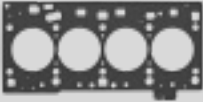
AUDI

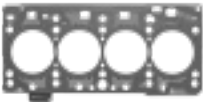
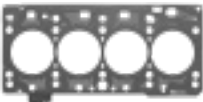
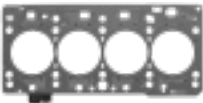

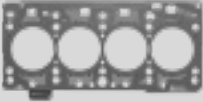

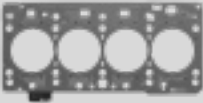

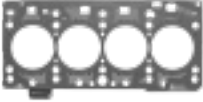
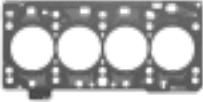
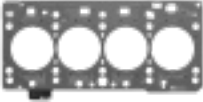

			<p>a) </p> <p>b) </p>	<p>K: </p> <p>N: </p>	
<p>VAS 235.610 FPM 724.590 036 109 675 A FPM 16x</p>	<p>902.561 04L 253 039 G </p>	<p>796.400 04L 129 717 F </p>	<p>a) 030.793 Dirko HT</p> <p>b) 567.640 N 908 132 01 M 14x1,5x22</p>	<p>K:← 340.290 04L 103 151 SP RD PTFE 35</p> <p>K:→ 340.280 04L 103 171 IWD LD PTFE 85</p> <p>N:← 897.690 03L 103 085 AW RD PTFE/ACM 32x47x10</p>	<p>TLS 696.000 </p>
<p>VAS 235.610 FPM 724.590 036 109 675 A FPM 16x</p>	<p>729.571 04L 253 039 B </p>	<p>352.810 04L 129 717 D </p>	<p>a) 030.793 Dirko HT</p> <p>b) 567.640 N 908 132 01 M 14x1,5x22</p>	<p>K:← 340.290 04L 103 151 SP RD PTFE 35</p> <p>K:→ 340.280 04L 103 171 IWD LD PTFE 85</p> <p>N:← 897.690 03L 103 085 AW RD PTFE/ACM 32x47x10</p>	<p>TLS 696.000 </p>









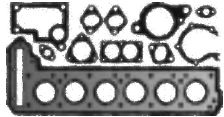
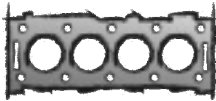

<p>AUDI</p> 				
<p>DSRB</p> <p>4 Cyl. 1968 ccm Cyl. 81,0 Ø</p> <p>A3 TDI 11/2019 →</p>		<p>823.931 05L 103 383 M 1,55 mm $\frac{+}{-}$ 82,3 Ø 1 ⊗</p>  <p>823.941 05L 103 383 N 1,63 mm $\frac{+}{-}$ 82,3 Ø 2 ⊗</p>  <p>823.951 05L 103 383 P 1,71 mm $\frac{+}{-}$ 82,3 Ø 3 ⊗</p> 	<p>ZKS 864.450 WHT 007 433 (10x) M 12x1,75x209</p> 	<p>461.682 EL-Liq 74 ↓</p>
<p>DSUD</p> <p>4 Cyl. 1968 ccm Cyl. 81,0 Ø</p> <p>A3 TDI 11/2019 →</p>		<p>823.931 05L 103 383 M 1,55 mm $\frac{+}{-}$ 82,3 Ø 1 ⊗</p>  <p>823.941 05L 103 383 N 1,63 mm $\frac{+}{-}$ 82,3 Ø 2 ⊗</p>  <p>823.951 05L 103 383 P 1,71 mm $\frac{+}{-}$ 82,3 Ø 3 ⊗</p> 	<p>ZKS 864.450 WHT 007 433 (10x) M 12x1,75x209</p> 	<p>461.682 EL-Liq 74 ↓</p>
<p>DTNA</p> <p>4 Cyl. 1968 ccm Cyl. 81,0 Ø</p> <p>A4 TDI 03/2019 →</p> <p>A5 TDI 10/2019 →</p> <p>Q5 TDI 09/2019 →</p>		<p>252.960 05L 103 383 AJ 1,55 mm $\frac{+}{-}$ 82,3 Ø 1 ⊗</p>  <p>252.970 05L 103 383 AK 1,63 mm $\frac{+}{-}$ 82,3 Ø 2 ⊗</p>  <p>252.980 05L 103 383 AL 1,71 mm $\frac{+}{-}$ 82,3 Ø 3 ⊗</p> 	<p>ZKS 864.450 WHT 007 433 (10x) M 12x1,75x209</p> 	<p>461.682 EL-Liq 74 ↓</p>
<p>DTNB</p> <p>4 Cyl. 1968 ccm Cyl. 81,0 Ø</p> <p>A4 TDI 07/2019 →</p>		<p>252.740 05L 103 383 AC 1,55 mm $\frac{+}{-}$ 82 Ø 1 ⊗</p>  <p>252.750 05L 103 383 AD 1,63 mm $\frac{+}{-}$ 82 Ø 2 ⊗</p>  <p>252.760 05L 103 383 AE 1,71 mm $\frac{+}{-}$ 82 Ø 3 ⊗</p> 	<p>ZKS 864.450 WHT 007 433 (10x) M 12x1,75x209</p> 	<p>461.682 EL-Liq 74 ↓</p>

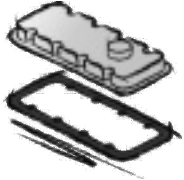
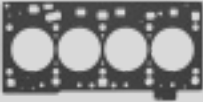
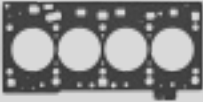

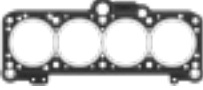
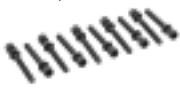





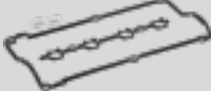





AUDI

			<p>a) </p> <p>b) </p>	<p>K: </p> <p>N: </p>	
<p>843.040 04E 109 675 L FPM 16x</p>	<p>786.270 05L 253 039 C</p>		<p>a) 030.793 Dirko HT</p> <p>b) 567.640 N 908 132 01 M 14x1,5x22</p>	<p>N:← 786.230 05L 103 085 C AW RD PTFE/ACM 26x41x8</p>	<p>TLS 035.850</p>
<p>843.040 04E 109 675 L FPM 16x</p>	<p>786.270 05L 253 039 C</p>		<p>a) 030.793 Dirko HT</p> <p>b) 567.640 N 908 132 01 M 14x1,5x22</p>	<p>N:← 786.230 05L 103 085 C AW RD PTFE/ACM 26x41x8</p>	
<p>843.040 04E 109 675 L FPM 16x</p>	<p>786.270 05L 253 039 C</p>	<p>649.910 05L 129 717</p> 	<p>a) 030.793 Dirko HT</p> <p>a) 860.780 05L 103 609 A</p> <p>b) 567.640 N 908 132 01 M 14x1,5x22</p>	<p>N:← 786.230 05L 103 085 C AW RD PTFE/ACM 26x41x8</p>	<p>TLS 036.940</p>
<p>843.040 04E 109 675 L FPM 16x</p>	<p>786.270 05L 253 039 C</p>	<p>649.910 05L 129 717</p> 	<p>a) 030.793 Dirko HT</p> <p>a) 860.780 05L 103 609 A</p> <p>b) 567.640 N 908 132 01 M 14x1,5x22</p>	<p>N:← 786.230 05L 103 085 C AW RD PTFE/ACM 26x41x8</p>	<p>TLS 036.940</p>

<p>AUDI</p> 				
<p>DTPA DTPB</p> <p>4 Cyl. 1968 ccm Cyl. 81,0 Ø</p> <p>A4 Allroad TDI 09/2020 →</p> <p>A4 TDI 05/2020 →</p> <p>A5 TDI 09/2020 →</p> <p>A6 Allroad TDI 09/2020 →</p> <p>A6 TDI 05/2018 →</p> <p>A7 TDI 09/2018 →</p> <p>Q5 TDI 11/2020 →</p>		<p>252.960 05L 103 383 AJ 1,55 mm $\frac{2}{3}$ 82,3 Ø 1 ⊗</p> <p>252.970 05L 103 383 AK 1,63 mm $\frac{2}{3}$ 82,3 Ø 2 ⊗</p>  <p>252.980 05L 103 383 AL 1,71 mm $\frac{2}{3}$ 82,3 Ø 3 ⊗</p> 	<p>ZKS 864.450 WHT 007 433 (10x) M 12x1,75x209</p> 	<p>ZKHS 094.190 786.220 05L 103 483 F</p> <p>461.682 EL-Liq 74 ↓</p> <p>811.540 04L 103 070 A (04L 103 469 A/P/S) 4x</p>
<p>DTRB DTRD</p> <p>4 Cyl. 1968 ccm Cyl. 81,0 Ø</p> <p>A3 TDI 11/2019 →</p> <p>Q2 TDI 04/2021 →</p>		<p>823.931 05L 103 383 M 1,55 mm $\frac{2}{3}$ 82,3 Ø 1 ⊗</p>  <p>823.941 05L 103 383 N 1,63 mm $\frac{2}{3}$ 82,3 Ø 2 ⊗</p>  <p>823.951 05L 103 383 P 1,71 mm $\frac{2}{3}$ 82,3 Ø 3 ⊗</p> 	<p>ZKS 864.450 WHT 007 433 (10x) M 12x1,75x209</p> 	<p>ZKHS 094.190 786.220 05L 103 483 F</p> <p>461.682 EL-Liq 74 ↓</p> <p>811.540 04L 103 070 A (04L 103 469 A/P/S) 4x</p>
<p>DTSA DTSB</p> <p>4 Cyl. 1968 ccm Cyl. 81,0 Ø</p> <p>A3 TDI 11/2019 →</p> <p>Q3 TDI 09/2018 →</p>		<p>823.931 05L 103 383 M 1,55 mm $\frac{2}{3}$ 82,3 Ø 1 ⊗</p>  <p>823.941 05L 103 383 N 1,63 mm $\frac{2}{3}$ 82,3 Ø 2 ⊗</p>  <p>823.951 05L 103 383 P 1,71 mm $\frac{2}{3}$ 82,3 Ø 3 ⊗</p> 	<p>ZKS 864.450 WHT 007 433 (10x) M 12x1,75x209</p> 	<p>ZKHS 094.190 786.220 05L 103 483 F</p> <p>461.682 EL-Liq 74 ↓</p> <p>811.540 04L 103 070 A (04L 103 469 A/P/S) 4x</p>
<p>DTTC</p> <p>4 Cyl. 1968 ccm Cyl. 81,0 Ø</p> <p>Q2 TDI 09/2016 →</p>		<p>823.931 05L 103 383 M 1,55 mm $\frac{2}{3}$ 82,3 Ø 1 ⊗</p>  <p>823.941 05L 103 383 N 1,63 mm $\frac{2}{3}$ 82,3 Ø 2 ⊗</p>  <p>823.951 05L 103 383 P 1,71 mm $\frac{2}{3}$ 82,3 Ø 3 ⊗</p> 	<p>ZKS 864.450 WHT 007 433 (10x) M 12x1,75x209</p> 	<p>461.682 EL-Liq 74 ↓</p>

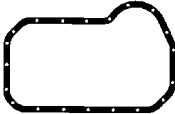
			<p>a) </p> <p>b) </p>	<p>K: </p> <p>N: </p>	
<p>843.040 04E 109 675 L FPM 16x</p>	<p>786.290 05L 253 039 E</p>		<p>a) 030.793 Dirko HT</p> <p>a) 860.780 05L 103 609 A</p> <p>b) 567.640 N 908 132 01 M 14x1,5x22</p>	<p>N:← 786.230 05L 103 085 C AW RD PTFE/ACM 26x41x8</p>	<p>TLS 036.980</p>
<p>843.040 04E 109 675 L FPM 16x</p>	<p>786.270 05L 253 039 C</p>		<p>a) 030.793 Dirko HT</p> <p>b) 567.640 N 908 132 01 M 14x1,5x22</p>	<p>N:← 786.230 05L 103 085 C AW RD PTFE/ACM 26x41x8</p>	
<p>843.040 04E 109 675 L FPM 16x</p>	<p>786.270 05L 253 039 C</p>		<p>a) 030.793 Dirko HT</p> <p>b) 567.640 N 908 132 01 M 14x1,5x22</p>	<p>N:← 786.230 05L 103 085 C AW RD PTFE/ACM 26x41x8</p>	<p>TLS 035.850</p>
<p>843.040 04E 109 675 L FPM 16x</p>			<p>a) 030.793 Dirko HT</p> <p>b) 567.640 N 908 132 01 M 14x1,5x22</p>	<p>N:← 786.230 05L 103 085 C AW RD PTFE/ACM 26x41x8</p>	

<p>AUDI</p> 				
<p>DTUA</p> <p>4 Cyl. 1968 ccm Cyl. 81,0 Ø</p> <p>A3 TDI 12/2020 →</p> <p>Q3 TDI 09/2020 →</p>		<p>252.960 05L 103 383 AJ 1,55 mm $\frac{\pm}{\text{mm}}$ 82,3 Ø 1 ⊗</p> <p>252.970 05L 103 383 AK 1,63 mm $\frac{\pm}{\text{mm}}$ 82,3 Ø 2 ⊗</p> <p>252.980 05L 103 383 AL 1,71 mm $\frac{\pm}{\text{mm}}$ 82,3 Ø 3 ⊗</p>  	<p>ZKS 864.450 WHT 007 433 (10x) M 12x1,75x209</p> 	<p>ZKHS 094.190 786.220 05L 103 483 F</p> <p>461.682 EL-Liq 74 ↓</p> <p>811.540 04L 103 070 A (04L 103 469 A/P/S) 4x</p>
<p>3A</p> <p>4 Cyl. 1984 ccm Cyl. 82,5 Ø</p> <p>80 08/1988 → 10/1990</p> <p>90 09/1987 → 10/1990</p> <p>Coupé 05/1989 → 07/1990</p>	<p>ES⊕ 765.636 053 198 012 A</p> <p>CS* 774.731 037 198 011 C</p>	<p>915.591 048 103 383 B 1,75 mm $\frac{\pm}{\text{mm}}$ 83 Ø</p> 	<p>ZKS 819.817 050 103 384 (10x) M 11x1,5x96</p> 	<p>ZKHS 314.773 046 198 025 A centr. 8,5 mm</p>  <p>ZKHS 457.200 026 198 025 C centr. 6,5 mm</p>  <p>447.050 026 103 483 F</p> 
<p>6A</p> <p>4 Cyl. 1984 ccm Cyl. 82,5 Ø</p> <p>80 03/1990 → 07/1992</p> <p>90 08/1989 → 07/1990</p> <p>Coupé 01/1992 → 07/1992</p>	<p>ES⊕ 917.699 053 198 012 B</p> <p>CS* 915.998 037 198 011 E</p>	<p>915.591 048 103 383 B 1,75 mm $\frac{\pm}{\text{mm}}$ 83 Ø</p> 	<p>ZKS 819.840 027 103 385 C (10x) M 11x1,5x148</p> 	<p>ZKHS 567.388 027 103 483 D</p> 

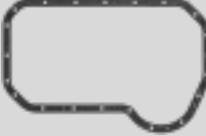
			<p>a) </p> <p>b) </p>	<p>K: </p> <p>N: </p>	
<p>843.040 04E 109 675 L FPM 16x</p>	<p>786.290 05L 253 039 E</p>		<p>a) 030.793 Dirko HT</p> <p>b) 567.640 N 908 132 01 M 14x1,5x22</p>	<p>N:← 786.230 05L 103 085 C AW RD PTFE/ACM 26x41x8</p>	<p>TLS 036.920</p>
<p>VAS 702.706 FPM</p> <p>553.190 026 109 675 FPM 8x</p>	<p>815.187 028 129 589 B 4x</p> 	<p>758.825 026 129 717 F</p> 	<p>a) 248.097 028 103 609 A</p>  <p>a) 495.620 044 103 609 D</p>  <p>b) 878.070 N 906 606 01 incl. 115.100 M 14x1,5x16</p> <p>b) 115.100 N 013 849.2 CU A 14x20x1,5</p>	<p>K:← 325.155 068 103 085 E ASW WD FPM/ACM 32x47x10</p> <p>K:→ 342.093 068 103 051 P ASW LD FPM 85x105x11</p> <p>K:→ 804.850 028 103 171 K SP LD PTFE/ACM 85</p> <p>K:→ 829.056 068 198 171 ASW LD FPM 85x105x11</p> <p>N:← 325.155 068 103 085 E ASW WD FPM/ACM 32x47x10</p>	
<p>VAS 825.042 FPM 2x</p> <p>701.289 027 109 675 FPM 16x</p>	<p>829.307 027 129 589 B 4x</p> 	<p>625.400 037 129 717 F</p> 	<p>a) 248.097 028 103 609 A</p>  <p>a) 495.620 044 103 609 D</p>  <p>b) 878.070 N 906 606 01 incl. 115.100 M 14x1,5x16</p> <p>b) 115.100 N 013 849.2 CU A 14x20x1,5</p>	<p>K:← 325.155 068 103 085 E ASW WD FPM/ACM 32x47x10</p> <p>K:→ 342.093 068 103 051 P ASW LD FPM 85x105x11</p> <p>K:→ 804.850 028 103 171 K SP LD PTFE/ACM 85</p> <p>K:→ 829.056 068 198 171 ASW LD FPM 85x105x11</p> <p>N:← 325.155 068 103 085 E ASW WD FPM/ACM 32x47x10</p>	

AUDI

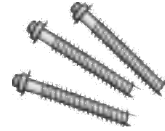
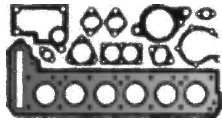

AAD
 4 Cyl. **1984 ccm**
 Cyl. 82,5 Ø
100
 12/1990 → 07/1994
80
 10/1990 → 08/1991
Coupé
 05/1989 → 12/1996

ES⊕ **915.971**
 048 198 012
 CS* **915.998**
 037 198 011 E

915.591
 048 103 383 B
 1,75 mm $\frac{\pm}{\pm}$ 83 Ø

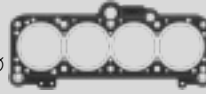

ZKS **819.817**
 050 103 384 (10x)
 M 11x1,5x96

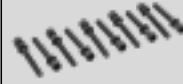

ZKHS **314.773**
 026 198 025 A
 centr. 8,5 mm



ZKHS **457.200**
 026 198 025 C
 centr. 6,5 mm



447.050
 026 103 483 F



AAE
 4 Cyl. **1984 ccm**
 Cyl. 82,5 Ø
100
 12/1990 → 07/1994
A6
 06/1994 → 12/1997

ES⊕ **915.971**
 048 198 012
 →4A-P-075 000
 ES⊕ **183.860**
 048 198 012 D
 Mot. AAE 032 210→
 ES⊕ **670.750**
 048 198 012 B
 →07/1994
 4A-P-075 000→
 ES⊕ **057.670**
 048 198 012 C
 07/1994→
 →Mot. AAE 032 209
 CS* **915.998**
 037 198 011 E
 →07/1994
 CS* **446.920**
 037 198 011 G
 07/1994→

915.591
 048 103 383 B
 1,75 mm $\frac{\pm}{\pm}$ 83 Ø
 →07/1994



627.811
 048 103 383 D
 1,65 mm $\frac{\pm}{\pm}$ 83,5 Ø
 07/1994→



ZKS **819.817**
 050 103 384 (10x)
 M 11x1,5x96

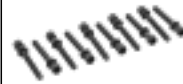

ZKHS **314.773**
 026 198 025 A
 centr. 8,5 mm
 →4A-P-075 000



ZKHS **457.200**
 026 198 025 C
 centr. 6,5 mm
 →4A-P-075 000



















447.050
 026 103 483 F
 →4A-P-075 000

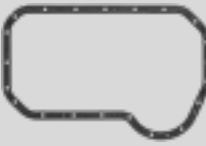

915.653
 051 103 483 E
 4A-P-075 001→



			<p>a) </p> <p>b) </p>	<p>K: </p> <p>N: </p>	
<p>VAS 702.706 FPM 553.190 026 109 675 FPM 8x</p>	<p>815.187 028 129 589 B 4x</p> 	<p>915.297 048 129 717 A</p> 	<p>a) 248.097 028 103 609 A</p>  <p>a) 495.620 044 103 609 D</p>  <p>b) 878.070 N 906 606 01 incl. 115.100 M 14x1,5x16</p> <p>b) 115.100 N 013 849.2 CU A 14x20x1,5</p>	<p>K:← 325.155 068 103 085 E ASW WD FPM/ACM 32x47x10</p> <p>K:→ 342.093 068 103 051 P ASW LD FPM 85x105x11</p> <p>K:→ 804.850 028 103 171 K SP LD PTFE/ACM 85</p> <p>K:→ 829.056 068 198 171 ASW LD FPM 85x105x11</p> <p>N:← 325.155 068 103 085 E ASW WD FPM/ACM 32x47x10</p>	
<p>VAS 702.706 FPM →Mot. AAE 032 209</p> <p>VAS 825.042 FPM Mot. AAE 032 210→</p> <p>553.190 026 109 675 FPM →Mot. AAE 032 209 8x</p> <p>701.289 027 109 675 FPM Mot. AAE 032 210→ 8x</p>	<p>815.187 028 129 589 B 4x</p> 	<p>460.745 035 121 171 C</p>  <p>915.300 048 129 717 B</p> 	<p>a) 248.097 028 103 609 A</p>  <p>a) 495.620 044 103 609 D</p>  <p>b) 878.070 N 906 606 01 incl. 115.100 M 14x1,5x16</p> <p>b) 115.100 N 013 849.2 CU A 14x20x1,5</p>	<p>K:← 325.155 068 103 085 E ASW WD FPM/ACM 32x47x10</p> <p>K:→ 342.093 068 103 051 P ASW LD FPM 85x105x11</p> <p>K:→ 804.850 028 103 171 K SP LD PTFE/ACM 85</p> <p>K:→ 829.056 068 198 171 ASW LD FPM 85x105x11</p> <p>N:← 325.155 068 103 085 E ASW WD FPM/ACM 32x47x10</p>	

AUDI

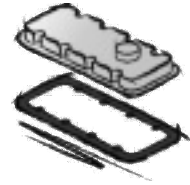
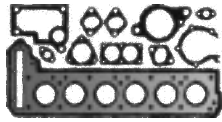

ABK
4 Cyl. **1984 ccm**
Cyl. 82,5 Ø

100
12/1990 → 07/1994

80
09/1991 → 01/1996

A6
06/1994 → 12/1997

Cabrio
01/1993 → 07/1998

Coupé
05/1989 → 12/1996

ES⊕ **915.971**
048 198 012
Coupé B3
→8B-P-006 500

80 B4
→8C-P-185 164

ES⊕ **670.750**
048 198 012 B
→06/1994

Coupé B3
8B-P-006 501→

80 B4
8C-P-185 165→

A6 4A2/4A5
4A-P-160 001→

ES⊕ **183.860**
048 198 012 D
Coupé B3
Cabrio B3
Mot. ABK 245 264→

A6 4A2/4A5
Mot. ABK 243 927→

80 B4
8C-S-064 385→

ES⊕ **057.670**
048 198 012 C
07/1994→

Coupé B3
Cabrio B3
→Mot. ABK 245 263

A6 4A2/4A5
→Mot. ABK 243 926

80 B4
→8C-S-064 384

CS* **446.920**
037 198 011 G

915.591
048 103 383 B
1,75 mm ± 83 Ø
→06/1994

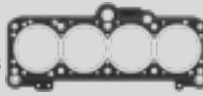

627.811
048 103 383 D
1,65 mm ± 83,5 Ø
07/1994→



ZKS **819.817**
050 103 384 (10x)
M 11x1,5x96



ZKHS **314.773**
026 198 025 A
centr. 8,5 mm
Coupé B3
→8B-P-006 500

80 B4
→8C-P-185 164



ZKHS **457.200**
026 198 025 C
centr. 6,5 mm
Coupé B3
→8B-P-006 500

80 B4
→8C-P-185 164



447.050
026 103 483 F
80 B4
→8C-P-185 164

Coupé B3
→8B-P-006 500

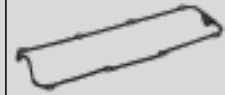







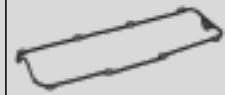



915.653
051 103 483 E
Coupé B3
8B-P-006 501→

80 B4
8C-P-185 165→

A6 4A2/4A5

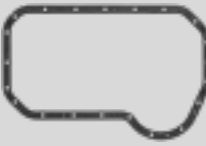

			<p>a) </p> <p>b) </p>	<p>K: </p> <p>N: </p>	
<p>VAS 702.706 FPM Cabrio B3 Coupé B3 →Mot. ABK 245 263</p> <hr/> <p>A6 4A2/4A5 →Mot. ABK 243 926</p> <hr/> <p>80 B4 →8C-S-064 384</p> <p>VAS 825.042 FPM Cabrio B3 Coupé B3 Mot. ABK 245 264→</p> <hr/> <p>A6 4A2/4A5 Mot. ABK 243 927→</p> <hr/> <p>80 B4 8C-S-064 385→</p> <p>553.190 026 109 675 FPM E A 8x</p> <hr/> <p>Cabrio B3 Coupé B3 →Mot. ABK 245 263</p> <hr/> <p>A6 4A2/4A5 →Mot. ABK 243 926</p> <hr/> <p>80 B4 →8C-S-064 384</p> <p>701.289 027 109 675 FPM E A 8x</p> <hr/> <p>Coupé B3 Cabrio B3 Mot. ABK 245 264→</p> <hr/> <p>A6 4A2/4A5 Mot. ABK 243 927→</p> <hr/> <p>80 B4 8C-S-064 385→</p>	<p>049.930 037 253 039 F</p> 	<p>915.297 048 129 717 A</p> 	<p>a) 248.097 028 103 609 A</p>  <p>a) 495.620 044 103 609 D</p>  <p>b) 878.070 N 906 606 01 incl. 115.100 M 14x1,5x16</p> <p>b) 115.100 N 013 849.2 CU A 14x20x1,5</p>	<p>K:← 325.155 068 103 085 E ASW WD FPM/ACM 32x47x10</p> <p>K:→ 342.093 068 103 051 P ASW LD FPM 85x105x11</p> <p>K:→ 804.850 028 103 171 K SP LD PTFE/ACM 85</p> <p>K:→ 829.056 068 198 171 ASW LD FPM 85x105x11</p> <p>N:← 325.155 068 103 085 E ASW WD FPM/ACM 32x47x10</p>	

AUDI

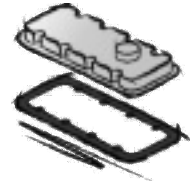

ABT
4 Cyl. **1984 ccm**
Cyl. 82,5 Ø
80
09/1991 → 01/1996

ES⊕ **915.971**
048 198 012
→8C-P-185 164
ES⊕ **670.750**
048 198 012 B
8C-P-185 165→
→Mot. ABT 246 861
ES⊕ **057.670**
048 198 012 C
8C-S-170 001→
→Mot. ABT 246 862
ES⊕ **183.860**
048 198 012 D
8C-S-170 001→
Mot. ABT 246 862→
CS* **446.920**
037 198 011 G

915.591
048 103 383 B
1,75 mm $\frac{+}{-}$ 83 Ø
→8C-S-170 000
627.811
048 103 383 D
1,65 mm $\frac{+}{-}$ 83,5 Ø
8C-S-170 001→

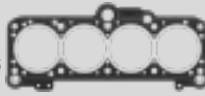

ZKS **819.817**
050 103 384 (10x)
M 11x1,5x96



ZKHS **314.773**
026 198 025 A
centr. 8,5 mm
→8C-P-185 164



ZKHS **457.200**
026 198 025 C
centr. 6,5 mm
→8C-P-185 164



447.050
026 103 483 F
→8C-P-185 164

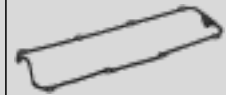

915.653
051 103 483 E
8C-P-185 165→



ACE
4 Cyl. **1984 ccm**
Cyl. 82,5 Ø
100
01/1992 → 07/1994
80
04/1992 → 01/1996
A6
06/1994 → 12/1997
Cabrio
06/1995 → 07/1996
Coupé
08/1992 → 12/1996

ES⊕ **917.699**
053 198 012 B
ES⊕ **630.670**
053 198 012 C
→Mot. ACE 017 543
CS* **915.998**
037 198 011 E

627.811
048 103 383 D
1,65 mm $\frac{+}{-}$ 83,5 Ø
915.591
048 103 383 B
1,75 mm $\frac{+}{-}$ 83 Ø



ZKS **819.840**
027 103 385 C (10x)
M 11x1,5x148
→Mot. ACE 017543



ZKS **057.440**
053 103 385 (10x)
M 11x1,5x142
Mot. ACE 017544→





















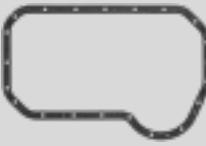

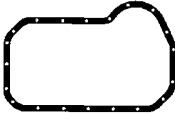



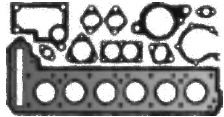
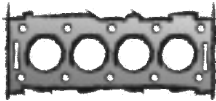

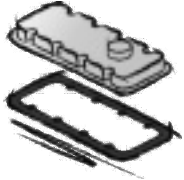
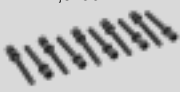
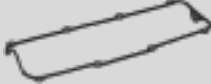
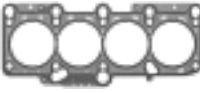
ZKHS **567.388**
027 103 483 D
→Mot. ACE 017 543







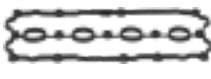

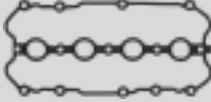

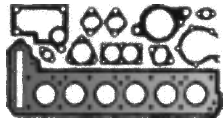
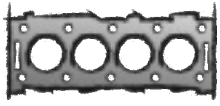

ZKHS **712.470**
051 198 025
Mot. ACE 017 544→

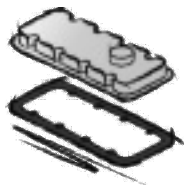
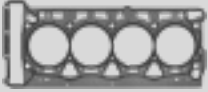

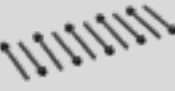
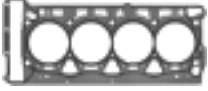

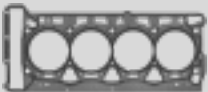

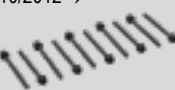

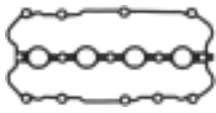



















			<p>a) </p> <p>b) </p>	<p>K: </p> <p>N: </p>	
<p>VAS 702.706 FPM →Mot. ABT 246 861</p> <p>VAS 825.042 FPM Mot. ABT 246 862→</p> <p>553.190 026 109 675 FPM →Mot. ABT 246 861 8x</p> <p>701.289 027 109 675 FPM Mot. ABT 246 862→ 8x</p>	<p>049.930 037 253 039 F</p> 	<p>915.300 048 129 717 B</p> 	<p>a) 248.097 028 103 609 A</p>  <p>a) 495.620 044 103 609 D</p>  <p>b) 878.070 N 906 606 01 incl. 115.100 M 14x1,5x16</p> <p>b) 115.100 N 013 849.2 CU A 14x20x1,5</p>	<p>K:← 325.155 068 103 085 E ASW WD FPM/ACM 32x47x10</p> <p>K:→ 342.093 068 103 051 P ASW LD FPM 85x105x11</p> <p>K:→ 804.850 028 103 171 K SP LD PTFE/ACM 85</p> <p>K:→ 829.056 068 198 171 ASW LD FPM 85x105x11</p> <p>N:← 325.155 068 103 085 E ASW WD FPM/ACM 32x47x10</p>	
<p>VAS 825.042 FPM 2x</p> <p>701.289 027 109 675 FPM 16x</p>	<p>829.307 027 129 589 B 4x</p> 	<p>625.400 037 129 717 F</p> 	<p>a) 248.097 028 103 609 A</p>  <p>a) 495.620 044 103 609 D</p>  <p>b) 878.070 N 906 606 01 incl. 115.100 M 14x1,5x16</p> <p>b) 115.100 N 013 849.2 CU A 14x20x1,5</p>	<p>K:← 325.155 068 103 085 E ASW WD FPM/ACM 32x47x10</p> <p>K:→ 342.093 068 103 051 P ASW LD FPM 85x105x11</p> <p>K:→ 804.850 028 103 171 K SP LD PTFE/ACM 85</p> <p>K:→ 829.056 068 198 171 ASW LD FPM 85x105x11</p> <p>N:← 325.155 068 103 085 E ASW WD FPM/ACM 32x47x10</p>	

AUDI 				
ADW 4 Cyl. 1984 ccm Cyl. 82,5 Ø 80 11/1993 → 01/1996 A6 06/1994 → 07/1995	ES⊕ 057.670 048 198 012 C →Mot. ADW 247 215 ES⊕ 183.860 048 198 012 D Mot. ADW 247 216→ CS* 446.920 037 198 011 G	915.591 048 103 383 B 1,75 mm $\frac{2}{3}$ 83 Ø 80 B4 →8C-S-170 000 627.811 048 103 383 D 1,65 mm $\frac{2}{3}$ 83,5 Ø 80 B4 8C-S-170 001→ A6 4A2/4A5 →4A-S-110 000	ZKS 819.817 050 103 384 (10x) M 11x1,5x96 	915.653 051 103 483 E 
ALT 4 Cyl. 1984 ccm Cyl. 82,5 Ø A4 11/2000 → 06/2008 A6 08/2001 → 01/2005	ES⊕ 504.550 CS* 898.340	744.361 06B 103 383 AF 0,90 mm $\frac{2}{3}$ 83,4 Ø 	ZKS 057.410 06B 103 385 (10x) M 10x1,5x132 	388.170 06B 103 483 H 
AWA BMB AXW 4 Cyl. 1984 ccm Cyl. 82,5 Ø A3 05/2003 → 06/2008 A4 07/2002 → 07/2005	ES⊕ 718.420 CS* 172.870	149.720 06D 103 383 L 0,90 mm $\frac{2}{3}$ 83,2 Ø 	ZKS 290.440 06D 103 385 (10x) M 10x1,5x129 	660.280 06D 103 483 D  461.682 EL-Liq 74 ↓
BLR BLY BVZ BLX BVY 4 Cyl. 1984 ccm Cyl. 82,5 Ø A3 05/2003 → 06/2008	ES⊕ 718.430 CS* 172.870	149.720 06D 103 383 L 0,90 mm $\frac{2}{3}$ 83,2 Ø 	ZKS 290.440 06D 103 385 (10x) M 10x1,5x129 	502.990 06D 103 483 E  461.682 EL-Liq 74 ↓
BGB BPJ BWE BYK BPG BUL BWT 4 Cyl. 1984 ccm Cyl. 82,5 Ø A4 11/2004 → 03/2009 A6 06/2005 → 08/2011	ES⊕ 718.440 CS* 178.580	376.843 06F 103 383 J 0,90 mm $\frac{2}{3}$ 83,3 Ø 	ZKS 325.930 06D 103 385 D (10x) M 10x1,5x117 	497.240 06F 103 483 D  461.682 EL-Liq 74 ↓

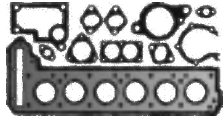
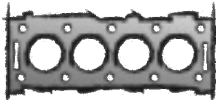

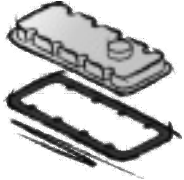
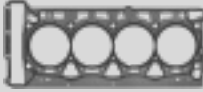

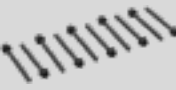
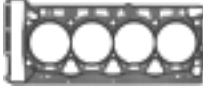

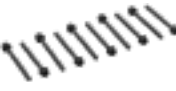
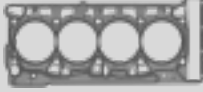
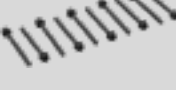







			<p>a) </p> <p>b) </p>	<p>K: </p> <p>N: </p>	
<p>VAS 702.706 FPM →Mot. ADW 247 215</p> <p>VAS 825.042 FPM Mot. ADW 247 216→</p> <p>553.190 026 109 675 FPM →Mot. ADW 247 215 8x</p> <p>701.289 027 109 675 FPM Mot. ADW 247 216→ 8x</p>	<p>815.187 028 129 589 B 4x</p>	<p>915.297 048 129 717 A</p>	<p>a) 495.620 044 103 609 D</p> <p>b) 878.070 N 906 606 01 incl. 115.100 M 14x1,5x16</p> <p>b) 115.100 N 013 849.2 CU A 14x20x1,5</p>	<p>K:← 325.155 068 103 085 E ASW WD FPM/ACM 32x47x10</p> <p>K:→ 342.093 068 103 051 P ASW LD FPM 85x105x11</p> <p>K:→ 804.850 028 103 171 K SP LD PTFE/ACM 85</p> <p>K:→ 829.056 068 198 171 ASW LD FPM 85x105x11</p> <p>N:← 325.155 068 103 085 E ASW WD FPM/ACM 32x47x10</p>	
<p>VAS 235.620 FPM</p> <p>724.590 036 109 675 A FPM 20x</p>	<p>744.321 06B 253 039 E</p>	<p>497.230 058 129 717 C 4x</p>	<p>a) 030.793 Dirko HT</p> <p>b) 567.640 N 908 132 01 M 14x1,5x22</p>	<p>K:← 155.560 038 103 085 E ASW RD PTFE/ACM 35x48x10</p> <p>K:→ 012.380 06B 103 171 B IWD LD PTFE/ACM 85</p> <p>N:← 129.780 038 103 085 C ASW RD PTFE/ACM 32x47x10 2x</p>	
<p>VAS 235.610 FPM</p> <p>724.590 036 109 675 A FPM 16x</p>	<p>744.321 06B 253 039 E</p>	<p>655.860 06D 129 717 D</p>	<p>a) 030.793 Dirko HT</p> <p>b) 567.640 N 908 132 01 M 14x1,5x22</p>	<p>K:← 155.560 038 103 085 E ASW RD PTFE/ACM 35x48x10</p> <p>K:→ 012.380 06B 103 171 B IWD LD PTFE/ACM 85</p> <p>N:← 129.780 038 103 085 C ASW RD PTFE/ACM 32x47x10</p>	
<p>VAS 235.610 FPM</p> <p>724.590 036 109 675 A FPM 16x</p>	<p>744.321 06B 253 039 E</p>	<p>655.860 06D 129 717 D</p>	<p>a) 030.793 Dirko HT</p> <p>b) 567.640 N 908 132 01 M 14x1,5x22</p>	<p>K:← 155.560 038 103 085 E ASW RD PTFE/ACM 35x48x10</p> <p>K:→ 012.380 06B 103 171 B IWD LD PTFE/ACM 85</p> <p>N:← 129.780 038 103 085 C ASW RD PTFE/ACM 32x47x10</p>	
<p>VAS 235.610 FPM</p> <p>724.590 036 109 675 A FPM 16x</p>	<p>150.860 06F 253 039 F</p>	<p>655.840 06F 129 717 D</p>	<p>a) 030.793 Dirko HT</p> <p>b) 567.640 N 908 132 01 M 14x1,5x22</p>	<p>K:← 155.560 038 103 085 E ASW RD PTFE/ACM 35x48x10</p> <p>K:→ 012.370 06A 103 171 A IWD LD PTFE/ACM 85</p> <p>N:← 129.780 038 103 085 C ASW RD PTFE/ACM 32x47x10</p>	<p>TLS 261.190</p>

AUDI 					
CAEA CAEB CAED CDNA CDNB CDNC CHJA 4 Cyl. 1984 ccm Cyl. 82,5 Ø A4 06/2008 → 12/2015 A4 Allroad 04/2009 → 05/2016 A5 06/2008 → 01/2017 A6 03/2011 → 09/2018 A8 02/2012 → 11/2015 Q5 11/2008 → 05/2017	ES⊕ 244.891 CS* 903.201	685.662 06H 103 383 AF 0,90 mm $\frac{\pm}{\pm}$ 83,3 Ø 	ZKS 325.930 06D 103 385 D (10x) M 10x1,5x117 →10/2012  ZKS 323.300 WHT 005 305 (10x) M10x1,5x115 10/2012→ 	461.682 EL-Liq 74	
CAWB CCTA 4 Cyl. 1984 ccm Cyl. 82,5 Ø A3 09/2004 → 05/2013 Q3 09/2014 → 10/2018 TT 08/2006 → 06/2010	ES⊕ 244.891 CS* 903.201	685.662 06H 103 383 AF 0,90 mm $\frac{\pm}{\pm}$ 83,3 Ø 	ZKS 325.930 06D 103 385 D (10x) M 10x1,5x117 	461.682 EL-Liq 74	
CBFA CCZC 4 Cyl. 1984 ccm Cyl. 82,5 Ø A3 09/2004 → 05/2013 Q3 06/2011 → 04/2015 TT 06/2008 → 06/2010	ES⊕ 244.891 CS* 903.201	685.662 06H 103 383 AF 0,90 mm $\frac{\pm}{\pm}$ 83,3 Ø 	ZKS 325.930 06D 103 385 D (10x) M 10x1,5x117 →10/2012  ZKS 323.300 WHT 005 305 (10x) M10x1,5x115 10/2012→ 	461.682 EL-Liq 74	
AXX BPY BZC BHZ BWA CDLA CDLB CDLC CDLH CDMA 4 Cyl. 1984 ccm Cyl. 82,5 Ø A1 03/2012 → 11/2012 A3 09/2004 → 03/2013 A3 S3 11/2006 → 03/2013 TT 08/2006 → 06/2014	ES⊕ 718.440 CS* 178.580	376.843 06F 103 383 J 0,90 mm $\frac{\pm}{\pm}$ 83,3 Ø 	ZKS 325.930 06D 103 385 D (10x) M 10x1,5x117 	497.240 06F 103 483 D  461.682 EL-Liq 74 ↓	

			<p>a) </p> <p>b) </p>	<p>K: </p> <p>N: </p>	
<p>VAS 235.610 FPM 724.590 036 109 675 A FPM 16x</p>	<p>150.860 06F 253 039 F </p>	<p>655.840 06F 129 717 D </p>	<p>a) 030.793 Dirko HT</p> <p>b) 567.640 N 908 132 01 M 14x1,5x22</p> <p>b) 858.050 N 911 679 01 incl. 591.840 M 14x1,5x15</p> <p>b) 591.840 N 013 815.8 Metal C 14x20x2</p>	<p>K:← 248.300 06L 103 085 B ASW RD PTFE/ACM 45x60x8</p> <p>K:→ 798.660 06K 103 171 G SP LD PTFE/ACM</p>	<p>TLS 948.660 </p>
<p>VAS 235.610 FPM 724.590 036 109 675 A FPM 16x</p>	<p>150.860 06F 253 039 F </p>	<p>655.840 06F 129 717 D </p>	<p>a) 030.793 Dirko HT</p> <p>b) 567.640 N 908 132 01 M 14x1,5x22</p> <p>b) 858.050 N 911 679 01 incl. 591.840 M 14x1,5x15</p> <p>b) 591.840 N 013 815.8 Metal C 14x20x2</p>	<p>K:← 248.300 06L 103 085 B ASW RD PTFE/ACM 45x60x8</p> <p>K:→ 798.660 06K 103 171 G SP LD PTFE/ACM</p>	<p>TLS 261.160 </p>
<p>VAS 235.610 FPM 724.590 036 109 675 A FPM 16x</p>	<p>150.860 06F 253 039 F </p>	<p>655.840 06F 129 717 D </p>	<p>a) 030.793 Dirko HT</p> <p>b) 567.640 N 908 132 01 M 14x1,5x22</p> <p>b) 858.050 N 911 679 01 incl. 591.840 M 14x1,5x15</p> <p>b) 591.840 N 013 815.8 Metal C 14x20x2</p>	<p>K:← 248.300 06L 103 085 B ASW RD PTFE/ACM 45x60x8</p> <p>K:→ 798.660 06K 103 171 G SP LD PTFE/ACM</p>	<p>TLS 261.160 </p>
<p>VAS 235.610 FPM 724.590 036 109 675 A FPM 16x</p>	<p>150.860 06F 253 039 F </p>	<p>655.840 06F 129 717 D </p>	<p>a) 030.793 Dirko HT</p> <p>b) 567.640 N 908 132 01 M 14x1,5x22</p>	<p>K:← 155.560 038 103 085 E ASW RD PTFE/ACM 35x48x10</p> <p>K:→ 012.370 06A 103 171 A IWD LD PTFE/ACM 85</p> <p>N:← 129.780 038 103 085 C ASW RD PTFE/ACM 32x47x10</p>	

AUDI 				
CESA CETA CPSA 4 Cyl. 1984 ccm Cyl. 82,5 Ø Q3 06/2011 → 04/2015 TT 05/2010 → 06/2014	ES⊕ 244.891 CS* 903.201	685.662 06H 103 383 AF 0,90 mm $\frac{1}{16}$ 83,3 Ø 	ZKS 325.930 06D 103 385 D (10x) M 10x1,5x117 →10/2012  ZKS 323.300 WHT 005 305 (10x) M10x1,5x115 10/2012→ 	461.682 EL-Liq 74
CFKA CPMA CPMB 4 Cyl. 1984 ccm Cyl. 82,5 Ø A4 06/2008 → 12/2015 A4 Allroad 04/2009 → 05/2016 A5 06/2008 → 01/2017 Q5 09/2012 → 05/2017	ES⊕ 430.920 CS* 903.201	685.662 06H 103 383 AF 0,90 mm $\frac{1}{16}$ 83,3 Ø 	ZKS 325.930 06D 103 385 D (10x) M 10x1,5x117 →10/2012  ZKS 323.300 WHT 005 305 (10x) M10x1,5x115 10/2012→ 	461.682 EL-Liq 74
CULB CULC 4 Cyl. 1984 ccm Cyl. 82,5 Ø Q3 11/2014 → 10/2018	ES⊕ 313.201 CS 798.670	008.040 06K 103 383 K 0,90 mm $\frac{1}{16}$ 83,3 Ø 	ZKS 323.300 WHT 005 305 (10x) M10x1,5x115 	461.682 EL-Liq 74

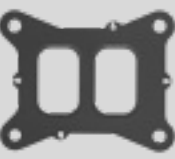
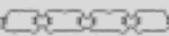





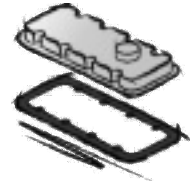
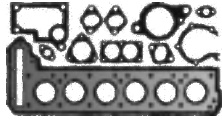











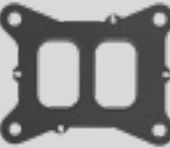

AUDI

			<p>a) </p> <p>b) </p>	<p>K: </p> <p>N: </p>	
<p>VAS 235.610 FPM 724.590 036 109 675 A FPM 16x</p>	<p>150.860 06F 253 039 F </p>	<p>655.840 06F 129 717 D </p>	<p>a) 030.793 Dirko HT</p> <p>b) 567.640 N 908 132 01 M 14x1,5x22</p> <p>b) 858.050 N 911 679 01 incl. 591.840 M 14x1,5x15</p> <p>b) 591.840 N 013 815.8 Metal C 14x20x2</p>	<p>K:← 248.300 06L 103 085 B ASW RD PTFE/ACM 45x60x8</p> <p>K:→ 798.660 06K 103 171 G SP LD PTFE/ACM</p>	
<p>VAS 235.610 FPM 724.590 036 109 675 A FPM 16x</p>	<p>150.860 06F 253 039 F </p>	<p>655.840 06F 129 717 D </p>	<p>a) 030.793 Dirko HT</p> <p>b) 567.640 N 908 132 01 M 14x1,5x22</p> <p>b) 858.050 N 911 679 01 incl. 591.840 M 14x1,5x15</p> <p>b) 591.840 N 013 815.8 Metal C 14x20x2</p>	<p>K:← 248.300 06L 103 085 B ASW RD PTFE/ACM 45x60x8</p> <p>K:→ 798.660 06K 103 171 G SP LD PTFE/ACM</p>	<p>TLS 948.660 </p>
<p>VAS 235.610 FPM 724.590 036 109 675 A FPM 16x</p>	<p>691.780 06L 253 039 </p>	<p>297.590 06K 129 717 A </p>	<p>a) 030.793 Dirko HT ↑ </p> <p>a) 398.260 06K 103 649</p> <p>b) 858.050 N 911 679 01 incl. 591.840 M 14x1,5x15</p> <p>b) 591.840 N 013 815.8 Metal C 14x20x2</p> <p>b) 813.036 N 013 815.6 CU C 14x20x2</p>	<p>K:← 248.300 06L 103 085 B ASW RD PTFE/ACM 45x60x8</p> <p>K:→ 798.660 06K 103 171 G SP LD PTFE/ACM</p>	<p>TLS 793.230 </p>

AUDI

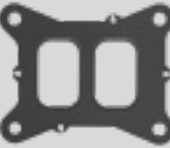

AUDI

			<p>a) </p> <p>b) </p>	<p>K: </p> <p>N: </p>	
<p>724.590 036 109 675 A FPM E 8x</p> <p>797.560 06L 09 675 C FPM A 8x</p>	<p>691.780 06L 253 039</p> 	<p>822.390 06K 129 717 K</p> 	<p>a) 030.793 Dirko HT ↑</p> <p>a) 478.650 06L 103 649 R</p>  <p>b) 588.690 06L 103 801</p>	<p>K:← 248.300 06L 103 085 B ASW RD PTFE/ACM 45x60x8</p> <p>K:→ 798.660 06K 103 171 G SP LD PTFE/ACM</p>	<p>TLS 878.330</p> 
<p>724.590 036 109 675 A FPM E 8x</p> <p>797.560 06L 09 675 C FPM A 8x</p>	<p>691.780 06L 253 039</p> 	<p>822.390 06K 129 717 K</p> 	<p>a) 030.793 Dirko HT ↑</p> <p>a) 478.650 06L 103 649 R</p>  <p>b) 588.690 06L 103 801</p>	<p>K:← 248.300 06L 103 085 B ASW RD PTFE/ACM 45x60x8</p> <p>K:→ 798.660 06K 103 171 G SP LD PTFE/ACM</p>	<p>TLS 878.330</p> 
<p>VAS 235.610 FPM</p> <p>724.590 036 109 675 A FPM 16x</p>	<p>691.780 06L 253 039</p> 	<p>297.590 06K 129 717 A</p> 	<p>a) 030.793 Dirko HT ↑</p> <p>a) 822.480 06L 103 649 S</p>  <p>b) 588.690 06L 103 801</p>	<p>K:← 248.300 06L 103 085 B ASW RD PTFE/ACM 45x60x8</p> <p>K:→ 798.660 06K 103 171 G SP LD PTFE/ACM</p>	<p>TLS 878.330</p> 

AUDI

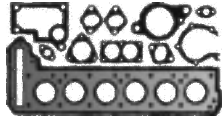

CZPA CZPB
CZPC CZRA
DKZA DKZB
DKZC DKZB

4 Cyl. **1984 ccm**
Cyl. 82,5 Ø

A1
09/2018 →

A3
05/2016 →

Q2
05/2017 →

Q3
02/2019 →

TT
07/2018 →

ES⊕ **503.950**
CS **798.670**

008.040
06K 103 383 K
0,90 mm $\frac{\pm}{\pm}$ 83,3 Ø

ZKS 323.300
WHT 005 305 (10x)
M10x1,5x115

461.682
EL-Liq 74

DAXB DAXC
DAYB

4 Cyl. **1984 ccm**
Cyl. 82,5 Ø

Q5
06/2016 →

ES⊕ **770.530**
CS* **877.300**
→11/2017

008.040
06K 103 383 K
0,90 mm $\frac{\pm}{\pm}$ 83,3 Ø

ZKS 323.300
WHT 005 305 (10x)
M10x1,5x115

461.682
EL-Liq 74

CYMC CYRB
CYRC DDWA
DKNA DLGA
DMFA DMFB

4 Cyl. **1984 ccm**
Cyl. 82,5 Ø

A4
05/2015 →

A4 Allroad
01/2016 →

A5
06/2016 →

A6
08/2018 →

A7
07/2018 →

Q5
04/2019 →

Q7
08/2015 →

Q8
10/2019 →

ES⊕ **770.530**
CS* **877.300**

008.040
06K 103 383 K
0,90 mm $\frac{\pm}{\pm}$ 83,3 Ø

ZKS 323.300
WHT 005 305 (10x)
M10x1,5x115

461.682
EL-Liq 74

DHHA

4 Cyl. **1984 ccm**
Cyl. 82,5 Ø

A3
07/2018 → 10/2020

Q3
05/2019 →

TT
09/2018 →



















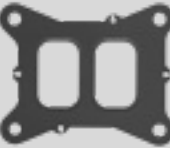





CS **798.670**





008.040
06K 103 383 K
0,90 mm $\frac{\pm}{\pm}$ 83,3 Ø





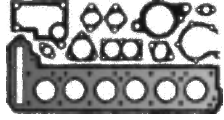
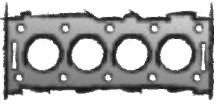

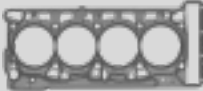
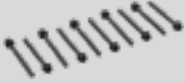
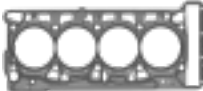
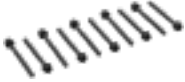

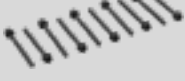
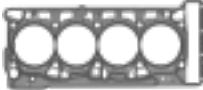
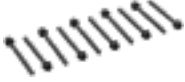









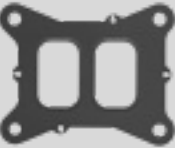

ZKS 323.300
WHT 005 305 (10x)
M10x1,5x115

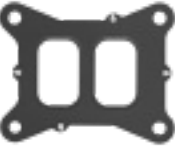
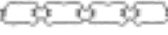

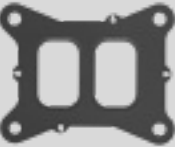
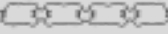
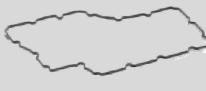

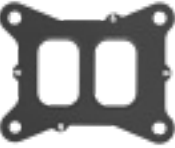
461.682
EL-Liq 74

AUDI



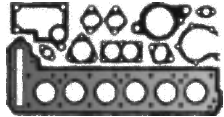
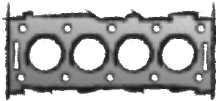

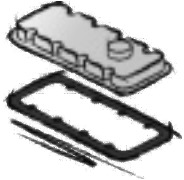
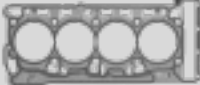
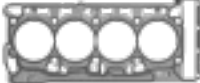
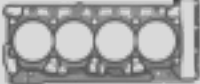

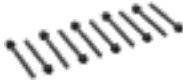
			<p>a) </p> <p>b) </p>	<p>K: </p> <p>N: </p>	
<p>724.590 036 109 675 A FPM E 8x</p> <p>797.560 06L 09 675 C FPM A 8x</p>	<p>691.780 06L 253 039</p> 	<p>822.390 06K 129 717 K</p> 	<p>a) 030.793 Dirko HT ↑</p> <p>a) 398.260 06K 103 649</p>  <p>b) 588.690 06L 103 801</p>	<p>K:← 248.300 06L 103 085 B ASW RD PTFE/ACM 45x60x8</p> <p>K:→ 798.660 06K 103 171 G SP LD PTFE/ACM</p>	<p>TLS 793.230</p> 
<p>724.590 036 109 675 A FPM E 8x</p> <p>797.560 06L 09 675 C FPM A 8x</p>	<p>691.780 06L 253 039</p> 	<p>297.590 06K 129 717 A</p> 	<p>a) 030.793 Dirko HT ↑</p> <p>a) 478.650 06L 103 649 R →11/2017</p>  <p>b) 588.690 06L 103 801</p>	<p>K:← 248.300 06L 103 085 B ASW RD PTFE/ACM 45x60x8</p> <p>K:→ 798.660 06K 103 171 G SP LD PTFE/ACM</p>	<p>TLS 878.330</p> 
<p>724.590 036 109 675 A FPM E 8x</p> <p>797.560 06L 09 675 C FPM A 8x</p>	<p>691.780 06L 253 039</p> 	<p>297.590 06K 129 717 A</p> 	<p>a) 030.793 Dirko HT ↑</p> <p>a) 478.650 06L 103 649 R</p>  <p>b) 588.690 06L 103 801</p>	<p>K:← 248.300 06L 103 085 B ASW RD PTFE/ACM 45x60x8</p> <p>K:→ 798.660 06K 103 171 G SP LD PTFE/ACM</p>	<p>TLS 878.330</p> 
<p>724.590 036 109 675 A FPM E 8x</p> <p>797.560 06L 09 675 C FPM A 8x</p>	<p>691.780 06L 253 039</p> 	<p>297.590 06K 129 717 A</p> 	<p>a) 030.793 Dirko HT ↑</p> <p>a) 398.260 06K 103 649</p>  <p>b) 588.690 06L 103 801</p>	<p>K:← 248.300 06L 103 085 B ASW RD PTFE/ACM 45x60x8</p> <p>K:→ 798.660 06K 103 171 G SP LD PTFE/ACM</p>	<p>TLS 793.230</p> 



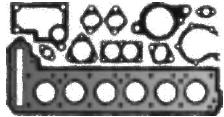
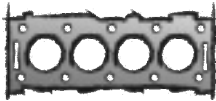

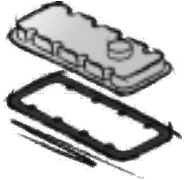

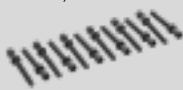









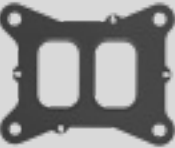

AUDI 					
CHHB CHHC CJXB CJXC CJXD CJXF CJXG CNTC CWZA CYFB DJHA DJHB DJJA 4 Cyl. 1984 ccm Cyl. 82,5 Ø A1 S1 03/2014 → 10/2018 A3 11/2013 → 10/2020 A3 S3 11/2012 → TT 07/2014 →	ES⊕ 313.201 CS 798.670	008.040 06K 103 383 K 0,90 mm $\frac{\pm}{\pm}$ 83,3 Ø 	ZKS 323.300 WHT 005 305 (10x) M10x1,5x115 	461.682 EL-Liq 74	
DKTA DKTB DKTC 4 Cyl. 1984 ccm Cyl. 82,5 Ø Q3 07/2018 → TT 07/2018 →	ES⊕ 770.530 CS 798.670	008.040 06K 103 383 K 0,90 mm $\frac{\pm}{\pm}$ 83,3 Ø 	ZKS 323.300 WHT 005 305 (10x) M10x1,5x115 	461.682 EL-Liq 74	
DLHA DLHB DLHC 4 Cyl. 1984 ccm Cyl. 82,5 Ø A4 Allroad 01/2016 → A5 06/2016 → A6 08/2018 → A7 07/2018 →	CS* 877.300	008.040 06K 103 383 K 0,90 mm $\frac{\pm}{\pm}$ 83,3 Ø 	ZKS 323.300 WHT 005 305 (10x) M10x1,5x115 	461.682 EL-Liq 74	
DLRA DNUE DNUF 4 Cyl. 1984 ccm Cyl. 82,5 Ø A3 S3 11/2012 → 10/2020 Q2 08/2018 → TT 07/2015 →	ES⊕ 503.950	008.040 06K 103 383 K 0,90 mm $\frac{\pm}{\pm}$ 83,3 Ø 	ZKS 323.300 WHT 005 305 (10x) M10x1,5x115 	461.682 EL-Liq 74	

			<p>a) </p> <p>b) </p>	<p>K: </p> <p>N: </p>	
<p>VAS 235.610 FPM 724.590 036 109 675 A FPM 16x</p>	<p>691.780 06L 253 039</p> 	<p>297.590 06K 129 717 A</p> 	<p>a) 030.793 Dirko HT ↑ a) 398.260 06K 103 649</p>  <p>b) 588.690 06L 103 801</p>	<p>K:← 248.300 06L 103 085 B ASW RD PTFE/ACM 45x60x8 K:→ 798.660 06K 103 171 G SP LD PTFE/ACM</p>	<p>TLS 793.230</p> 
<p>724.590 036 109 675 A FPM E 8x 797.560 06L 09 675 C FPM A 8x</p>	<p>691.780 06L 253 039</p> 	<p>297.590 06K 129 717 A</p> 	<p>a) 030.793 Dirko HT ↑ a) 398.260 06K 103 649</p>  <p>b) 588.690 06L 103 801</p>	<p>K:← 248.300 06L 103 085 B ASW RD PTFE/ACM 45x60x8 K:→ 798.660 06K 103 171 G SP LD PTFE/ACM</p>	<p>TLS 793.230</p> 
<p>724.590 036 109 675 A FPM E 8x 797.560 06L 09 675 C FPM A 8x</p>	<p>691.780 06L 253 039</p> 	<p>297.590 06K 129 717 A</p> 	<p>a) 030.793 Dirko HT ↑ a) 478.650 06L 103 649 R</p>  <p>b) 588.690 06L 103 801</p>	<p>K:← 248.300 06L 103 085 B ASW RD PTFE/ACM 45x60x8 K:→ 798.660 06K 103 171 G SP LD PTFE/ACM</p>	<p>TLS 878.330</p> 
<p>724.590 036 109 675 A FPM E 8x 797.560 06L 09 675 C FPM A 8x</p>	<p>691.780 06L 253 039</p> 	<p>822.390 06K 129 717 K</p> 	<p>a) 030.793 Dirko HT ↑ a) 398.260 06K 103 649</p>  <p>b) 588.690 06L 103 801</p>	<p>K:← 248.300 06L 103 085 B ASW RD PTFE/ACM 45x60x8 K:→ 798.660 06K 103 171 G SP LD PTFE/ACM</p>	<p>TLS 793.230</p> 

AUDI 				
DMSA DMSB 4 Cyl. 1984 ccm Cyl. 82,5 Ø A4 12/2018 → A5 08/2018 → Q5 10/2021 →	CS* 877.300	564.670 06N 103 383 A 0,90 mm $\frac{\pm}{\pm}$ 83,3 Ø 		461.682 EL-Liq 74
DNNA DNNB DNND 4 Cyl. 1984 ccm Cyl. 82,5 Ø A1 04/2021 → A3 05/2021 → Q3 07/2018 → TT 07/2018 →	CS 798.670	564.670 06N 103 383 A 0,90 mm $\frac{\pm}{\pm}$ 83,3 Ø 		461.682 EL-Liq 74
DNPA 4 Cyl. 1984 ccm Cyl. 82,5 Ø Q3 01/2021 →	CS 798.670	564.640 06N 103 383 B 0,90 mm $\frac{\pm}{\pm}$ 83,3 Ø 		461.682 EL-Liq 74
DNNTA 4 Cyl. 1984 ccm Cyl. 82,5 Ø Q5 12/2018 →	ES⊕ 770.530 CS* 877.300 →11/2017	008.040 06K 103 383 K 0,90 mm $\frac{\pm}{\pm}$ 83,3 Ø 	ZKS 323.300 WHT 005 305 (10x) M10x1,5x115 	461.682 EL-Liq 74
DPAA 4 Cyl. 1984 ccm Cyl. 82,5 Ø A4 08/2020 → A4 Allroad 08/2020 → A5 10/2019 → A6 05/2020 →				

			<p>a) </p> <p>b) </p>	<p>K: </p> <p>N: </p>	
<p>724.590 036 109 675 A FPM E 8x</p> <p>797.560 06L 09 675 C FPM A 8x</p>	<p>691.780 06L 253 039</p> 	<p>822.390 06K 129 717 K</p> 	<p>a) 030.793 Dirko HT ↑</p> <p>a) 478.650 06L 103 649 R</p>  <p>b) 588.690 06L 103 801</p>	<p>K:← 248.300 06L 103 085 B ASW RD PTFE/ACM 45x60x8</p> <p>K:→ 798.660 06K 103 171 G SP LD PTFE/ACM</p>	<p>TLS 041.450</p>
<p>724.590 036 109 675 A FPM E 8x</p> <p>797.560 06L 09 675 C FPM A 8x</p>	<p>691.780 06L 253 039</p> 	<p>822.390 06K 129 717 K</p> 	<p>a) 030.793 Dirko HT ↑</p> <p>b) 588.690 06L 103 801</p>	<p>K:← 248.300 06L 103 085 B ASW RD PTFE/ACM 45x60x8</p> <p>K:→ 798.660 06K 103 171 G SP LD PTFE/ACM</p>	<p>TLS 033.070</p>
<p>724.590 036 109 675 A FPM E 8x</p> <p>797.560 06L 09 675 C FPM A 8x</p>	<p>691.780 06L 253 039</p> 		<p>a) 030.793 Dirko HT ↑</p> <p>b) 588.690 06L 103 801</p>	<p>K:← 248.300 06L 103 085 B ASW RD PTFE/ACM 45x60x8</p> <p>K:→ 798.660 06K 103 171 G SP LD PTFE/ACM</p>	<p>TLS 033.070</p>
<p>724.590 036 109 675 A FPM 8x</p> <p>797.560 06L 09 675 C FPM A 8x</p>	<p>691.780 06L 253 039</p> 	<p>297.590 06K 129 717 A</p> 	<p>a) 030.793 Dirko HT ↑</p> <p>a) 478.650 06L 103 649 R →11/2017</p>  <p>b) 588.690 06L 103 801</p>	<p>K:← 248.300 06L 103 085 B ASW RD PTFE/ACM 45x60x8</p> <p>K:→ 798.660 06K 103 171 G SP LD PTFE/ACM</p>	<p>TLS 878.330</p> 
					<p>TLS 041.450</p>

<p>AUDI</p> 				
<p>DMTA DPUA DMTC DPVA</p> <p>4 Cyl. 1984 ccm Cyl. 82,5 Ø</p> <p>A4 08/2020 →</p> <p>A4 Allroad 08/2020 →</p> <p>A5 10/2019 →</p> <p>A6 05/2020 →</p> <p>A7 05/2020 →</p> <p>Q5 08/2020 →</p>	<p>CS* 877.300</p>	<p>564.640 06N 103 383 B 0,90 mm $\frac{2}{3}$ 83,3 Ø</p> 		<p>461.682 EL-Liq 74</p>
<p>DRYA</p> <p>4 Cyl. 1984 ccm</p> <p>A6 11/2019 →</p> <p>A7 07/2019 →</p> <p>Q5 02/2021 →</p>				
<p>NC</p> <p>5 Cyl. 1986 ccm Cyl. 76,5 Ø</p> <p>100 TD 03/1988 → 11/1990</p>	<p>CS* 917.710 046 198 011</p>	<p>820.393 069 103 383 CN 0,800 mm → 0,900 mm 1,57 mm $\frac{2}{3}$ 78 Ø 2 ⊗</p> 	<p>ZKS 819.875 068 103 384 A (12x) M 12x1,75x115</p> 	
<p>NM</p> <p>5 Cyl. 1994 ccm Cyl. 81,0 Ø</p> <p>90 08/1988 → 09/1991</p> <p>Coupé 08/1989 → 07/1991</p>	<p>CS* 164.320 034 198 011 B</p>	<p>214.390 034 103 383 AD 1,65 mm $\frac{2}{3}$ 82 Ø</p> 		<p>ZKHS 915.572 034 198 025 F</p> 

			<p>a) </p> <p>b) </p>	<p>K: </p> <p>N: </p>	
<p>724.590 036 109 675 A FPM E 8x</p> <p>797.560 06L 09 675 C FPM A 8x</p>	<p>691.780 06L 253 039</p> 	<p>822.390 06K 129 717 K</p> 	<p>a) 030.793 Dirko HT ↑</p> <p>a) 478.650 06L 103 649 R</p>  <p>b) 588.690 06L 103 801</p>	<p>K:← 248.300 06L 103 085 B ASW RD PTFE/ACM 45x60x8</p> <p>K:→ 798.660 06K 103 171 G SP LD PTFE/ACM</p>	<p>TLS 041.450</p>
	<p>691.780 06L 253 039</p> 				<p>TLS 041.450</p>
<p>VAS 730.130 FPM</p> <p>553.190 026 109 675 FPM 10x</p>	<p>815.187 028 129 589 B 5x</p> 	<p>826.227 034 129 717 M</p> 	<p>a) 107.256 054 103 609</p>  <p>b) 878.070 N 906 606 01 incl. 115.100 M 14x1,5x16</p> <p>b) 115.100 N 013 849.2 CU A 14x20x1,5</p>	<p>K:← 325.155 068 103 085 E ASW WD FPM/ACM 32x47x10</p> <p>K:→ 342.093 068 103 051 P ASW LD FPM 85x105x11</p> <p>K:→ 804.850 028 103 171 K SP LD PTFE/ACM 85</p> <p>K:→ 829.056 068 198 171 ASW LD FPM 85x105x11</p> <p>N:← 325.155 068 103 085 E ASW WD FPM/ACM 32x47x10</p>	
<p>701.289 027 109 675 FPM 20x</p>	<p>829.307 027 129 589 B 5x</p> 	<p>623.270 034 129 717 K</p> 	<p>a) 915.311 074 103 609 F 1 mm</p>  <p>b) 878.070 N 906 606 01 incl. 115.100 M 14x1,5x16</p> <p>b) 115.100 N 013 849.2 CU A 14x20x1,5</p>	<p>K:← 294.357 069 115 147 E ASW RD FPM/ACM 35x48x10</p> <p>K:← 475.961 054 115 147 B ASW RD FPM 35x48x10</p> <p>K:→ 342.093 068 103 051 P ASW LD FPM 85x105x11</p> <p>K:→ 804.850 028 103 171 K SP LD PTFE/ACM 85</p> <p>K:→ 829.056 068 198 171 ASW LD FPM 85x105x11</p> <p>N:← 325.155 068 103 085 E ASW WD FPM/ACM 32x47x10</p>	

AUDI



PS
5 Cyl. **1994 ccm**
Cyl. 81,0 Ø
90
07/1988 → 09/1991

ES⊕ **899.887**
034 198 012 H
CS* **547.477**
034 198 011 C

826.219
034 103 383 AA
1,75 mm $\frac{+}{-}$ 82,7 Ø



ZKS 819.850
050 103 384 (12x)
M 11x1,5x96

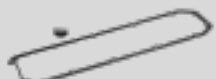

ZKHS 692.751
034 198 025 A
ZKHS 914.398
034 198 025 D

RT
5 Cyl. **1994 ccm**
Cyl. 81,0 Ø
100
01/1988 → 11/1990

ES⊕ **826.596**
035 198 012 Q
CS* **547.477**
034 198 011 C

826.219
034 103 383 AA
1,75 mm $\frac{+}{-}$ 82,7 Ø



ZKS 819.850
050 103 384 (12x)
M 11x1,5x96

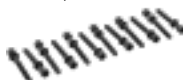

ZKHS 692.751
034 198 025 A
ZKHS 914.398
034 198 025 D

3B **AAN**
ABY **ADU**
RR
5 Cyl. **2226 ccm**
Cyl. 81,0 Ø
100
08/1991 → 07/1994
100 S4 Turbo
09/1991 → 07/1994
200 Turbo
03/1989 → 12/1990
80
02/1993 → 07/1995
80 RS2
03/1994 → 05/1995
80 S2
02/1993 → 12/1994
A6 S6
06/1994 → 12/1997
Coupé S2
09/1990 → 12/1996
QUATTRO Turbo
08/1989 → 07/1991

















CS* **164.320**
034 198 011 B

214.390
034 103 383 AD
1,65 mm $\frac{+}{-}$ 82 Ø



ZKHS 915.572
034 198 025 F







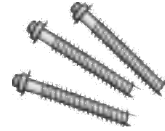
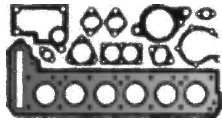























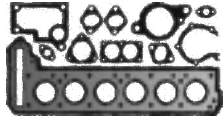
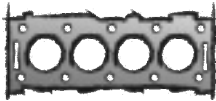

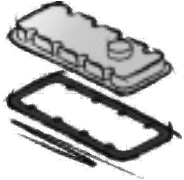
			<p>a) </p> <p>b) </p>	<p>K: </p> <p>N: </p>	
<p>VAS 730.130 FPM 553.190 026 109 675 FPM 10x</p>	<p>815.187 028 129 589 B 5x</p> 	<p>816.507 034 129 717 F</p> 	<p>a) 107.256 054 103 609</p>  <p>b) 878.070 N 906 606 01 incl. 115.100 M 14x1,5x16</p> <p>b) 115.100 N 013 849.2 CU A 14x20x1,5</p>	<p>K:← 294.357 069 115 147 E ASW RD FPM/ACM 35x48x10</p> <p>K:← 475.961 054 115 147 B ASW RD FPM 35x48x10</p> <p>K:→ 342.093 068 103 051 P ASW LD FPM 85x105x11</p> <p>K:→ 804.850 028 103 171 K SP LD PTFE/ACM 85</p> <p>K:→ 829.056 068 198 171 ASW LD FPM 85x105x11</p> <p>N:← 325.155 068 103 085 E ASW WD FPM/ACM 32x47x10</p>	
<p>VAS 730.130 FPM 553.190 026 109 675 FPM 10x</p>	<p>815.187 028 129 589 B 5x</p> 	<p>816.507 034 129 717 F</p> 	<p>a) 107.256 054 103 609</p>  <p>b) 878.070 N 906 606 01 incl. 115.100 M 14x1,5x16</p> <p>b) 115.100 N 013 849.2 CU A 14x20x1,5</p>	<p>K:← 294.357 069 115 147 E ASW RD FPM/ACM 35x48x10</p> <p>K:← 475.961 054 115 147 B ASW RD FPM 35x48x10</p> <p>K:→ 342.093 068 103 051 P ASW LD FPM 85x105x11</p> <p>K:→ 804.850 028 103 171 K SP LD PTFE/ACM 85</p> <p>K:→ 829.056 068 198 171 ASW LD FPM 85x105x11</p> <p>N:← 325.155 068 103 085 E ASW WD FPM/ACM 32x47x10</p>	
<p>701.289 027 109 675 FPM 20x</p>	<p>724.940 034 129 589 A</p> 	<p>623.270 034 129 717 K</p> 	<p>a) 915.311 074 103 609 F 1 mm</p>  <p>b) 589.680 059 103 193 M 26x1,5x16</p> <p>b) 878.080 incl. 133.051 059 103 193 M 26x1,5x16</p> <p>b) 133.051 N 043 854.1 CU A 26x31x2</p>	<p>K:← 294.357 069 115 147 E ASW RD FPM/ACM 35x48x10</p> <p>K:← 475.961 054 115 147 B ASW RD FPM 35x48x10</p> <p>K:→ 342.093 068 103 051 P ASW LD FPM 85x105x11</p> <p>K:→ 804.850 028 103 171 K SP LD PTFE/ACM 85</p> <p>K:→ 829.056 068 198 171 ASW LD FPM 85x105x11</p> <p>N:← 325.155 068 103 085 E ASW WD FPM/ACM 32x47x10</p>	

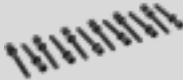
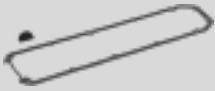

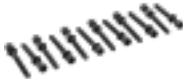



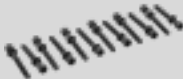

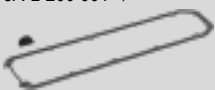









AUDI

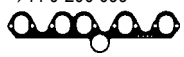

AUDI

			<p>a) </p> <p>b) </p>	<p>K: </p> <p>N: </p>	
<p>VAS 730.130 FPM 553.190 026 109 675 FPM 10x</p>	<p>815.187 028 129 589 B 5x</p> 	<p>826.308 034 129 717 H</p> 	<p>a) 107.256 054 103 609</p>  <p>b) 878.070 N 906 606 01 incl. 115.100 M 14x1,5x16</p> <p>b) 115.100 N 013 849.2 CU A 14x20x1,5</p>	<p>K:← 294.357 069 115 147 E ASW RD FPM/ACM 35x48x10</p> <p>K:← 475.961 054 115 147 B ASW RD FPM 35x48x10</p> <p>K:→ 342.093 068 103 051 P ASW LD FPM 85x105x11</p> <p>K:→ 804.850 028 103 171 K SP LD PTFE/ACM 85</p> <p>K:→ 829.056 068 198 171 ASW LD FPM 85x105x11</p> <p>N:← 325.155 068 103 085 E ASW WD FPM/ACM 32x47x10</p>	
<p>VAS 730.130 FPM 553.190 026 109 675 FPM 10x</p>	<p>815.187 028 129 589 B 5x</p> 	<p>826.227 034 129 717 M</p> 	<p>a) 107.256 054 103 609</p>  <p>b) 878.070 N 906 606 01 incl. 115.100 M 14x1,5x16</p> <p>b) 115.100 N 013 849.2 CU A 14x20x1,5</p>	<p>K:← 294.357 069 115 147 E ASW RD FPM/ACM 35x48x10</p> <p>K:← 475.961 054 115 147 B ASW RD FPM 35x48x10</p> <p>K:→ 342.093 068 103 051 P ASW LD FPM 85x105x11</p> <p>K:→ 804.850 028 103 171 K SP LD PTFE/ACM 85</p> <p>K:→ 829.056 068 198 171 ASW LD FPM 85x105x11</p> <p>N:← 325.155 068 103 085 E ASW WD FPM/ACM 32x47x10</p>	
<p>701.289 027 109 675 FPM 20x</p>	<p>829.307 027 129 589 B 5x</p> 	<p>623.270 034 129 717 K</p> 	<p>a) 915.311 074 103 609 F 1 mm</p>  <p>b) 589.680 059 103 193 M 26x1,5x16</p> <p>b) 878.080 incl. 133.051 059 103 193 M 26x1,5x16</p> <p>b) 133.051 N 043 854.1 CU A 26x31x2</p>	<p>K:← 294.357 069 115 147 E ASW RD FPM/ACM 35x48x10</p> <p>K:← 475.961 054 115 147 B ASW RD FPM 35x48x10</p> <p>K:→ 342.093 068 103 051 P ASW LD FPM 85x105x11</p> <p>K:→ 804.850 028 103 171 K SP LD PTFE/ACM 85</p> <p>K:→ 829.056 068 198 171 ASW LD FPM 85x105x11</p> <p>N:← 325.155 068 103 085 E ASW WD FPM/ACM 32x47x10</p>	

<p>AUDI</p> 				
<p>AAR</p> <p>5 Cyl. 2309 ccm Cyl. 82,5 Ø</p> <p>100 12/1990 → 07/1994</p> <p>A6 06/1994 → 12/1995</p>	<p>ES⊕ 623.440 034 198 012 L</p> <p>CS* 547.477 034 198 011 C</p>	<p>915.491 054 103 383 L 1,75 mm $\frac{+}{-}$ 83,5 Ø</p> 	<p>ZKS 819.850 050 103 384 (12x) M 11x1,5x96</p> 	<p>ZKHS 198.410 034 198 025 C</p> 
<p>NF</p> <p>5 Cyl. 2309 ccm Cyl. 82,5 Ø</p> <p>100 08/1986 → 07/1991</p> <p>200 11/1986 → 09/1991</p>	<p>ES⊕ 915.947 034 198 012 K →44-J-200 099</p> <p>ES⊕ 915.963 034 198 012 E 44-J-200 100→</p> <p>CS* 547.477 034 198 011 C</p>	<p>915.491 054 103 383 L 1,75 mm $\frac{+}{-}$ 83,5 Ø</p> 	<p>ZKS 819.850 050 103 384 (12x) M 11x1,5x96</p> 	<p>ZKHS 692.751 034 198 025 A</p>  <p>ZKHS 914.398 034 198 025 D</p> 
<p>NG</p> <p>5 Cyl. 2309 ccm Cyl. 82,5 Ø</p> <p>80 10/1987 → 01/1996</p> <p>90 04/1987 → 09/1991</p> <p>Cabrio 05/1991 → 07/1994</p> <p>Coupé 08/1986 → 12/1996</p>	<p>ES⊕ 915.963 034 198 012 E →8A-L-200 000 →8B-L-014 000 →44-L-072 000</p> <p>ES⊕ 623.440 034 198 012 L 8A-L-200 001→ 8B-L 014 001→ 44-L-072 001→</p> <p>CS* 547.477 034 198 011 C</p>	<p>915.491 054 103 383 L 1,75 mm $\frac{+}{-}$ 83,5 Ø</p> 	<p>ZKS 819.850 050 103 384 (12x) M 11x1,5x96</p> 	<p>ZKHS 692.751 034 198 025 A →44-L-072 000 →8B-L-014 000 →8A-L-200 000</p>  <p>ZKHS 914.398 034 198 025 D →8B-L-014 000 →44-L-072 000 →8A-L-200 000</p>  <p>ZKHS 198.410 034 198 025 C 8B-L-014 001→ 44-L-072 001→ 8A-L-200 001→</p> 

			<p>a) </p> <p>b) </p>	<p>K: </p> <p>N: </p>	
<p>VAS 730.130 FPM 553.190 026 109 675 FPM 10x</p>	<p>815.187 028 129 589 B 5x</p> 	<p>816.507 034 129 717 F</p> 	<p>a) 107.256 054 103 609</p>  <p>b) 878.070 N 906 606 01 incl. 115.100 M 14x1,5x16</p> <p>b) 115.100 N 013 849.2 CU A 14x20x1,5</p>	<p>K:← 294.357 069 115 147 E ASW RD FPM/ACM 35x48x10</p> <p>K:← 475.961 054 115 147 B ASW RD FPM 35x48x10</p> <p>K:→ 342.093 068 103 051 P ASW LD FPM 85x105x11</p> <p>K:→ 804.850 028 103 171 K SP LD PTFE/ACM 85</p> <p>K:→ 829.056 068 198 171 ASW LD FPM 85x105x11</p> <p>N:← 325.155 068 103 085 E ASW WD FPM/ACM 32x47x10</p>	
<p>VAS 730.130 FPM 553.190 026 109 675 FPM 10x</p>	<p>815.187 028 129 589 B 5x</p> 	<p>826.227 034 129 717 M →44-J-200 099</p>  <p>816.507 034 129 717 F 44-J-200 100→</p> 	<p>a) 107.256 054 103 609</p>  <p>b) 878.070 N 906 606 01 incl. 115.100 M 14x1,5x16</p> <p>b) 115.100 N 013 849.2 CU A 14x20x1,5</p>	<p>K:← 294.357 069 115 147 E ASW RD FPM/ACM 35x48x10</p> <p>K:← 475.961 054 115 147 B ASW RD FPM 35x48x10</p> <p>K:→ 342.093 068 103 051 P ASW LD FPM 85x105x11</p> <p>K:→ 804.850 028 103 171 K SP LD PTFE/ACM 85</p> <p>K:→ 829.056 068 198 171 ASW LD FPM 85x105x11</p> <p>N:← 325.155 068 103 085 E ASW WD FPM/ACM 32x47x10</p>	
<p>VAS 730.130 FPM 553.190 026 109 675 FPM 10x</p>	<p>815.187 028 129 589 B 5x</p> 	<p>816.507 034 129 717 F</p> 	<p>a) 107.256 054 103 609</p>  <p>b) 878.070 N 906 606 01 incl. 115.100 M 14x1,5x16</p> <p>b) 115.100 N 013 849.2 CU A 14x20x1,5</p>	<p>K:← 294.357 069 115 147 E ASW RD FPM/ACM 35x48x10</p> <p>K:← 475.961 054 115 147 B ASW RD FPM 35x48x10</p> <p>K:→ 342.093 068 103 051 P ASW LD FPM 85x105x11</p> <p>K:→ 804.850 028 103 171 K SP LD PTFE/ACM 85</p> <p>K:→ 829.056 068 198 171 ASW LD FPM 85x105x11</p> <p>N:← 325.155 068 103 085 E ASW WD FPM/ACM 32x47x10</p>	

AUDI

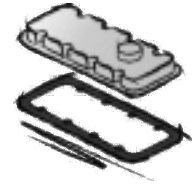

3D
AAS

5 Cyl. **2370 ccm**
Cyl. 79,5 Ø

100

08/1989 → 07/1994

ES⊕ **915.173**
074 198 012



CS* **632.190**
074 198 011 A

757.691
074 103 383 C



→ 0,660 mm
→ 0,870 mm

1,53 mm $\frac{1}{2}$ 81 Ø
1 ⊗

ZKS 819.875
068 103 384 A (12x)
M 12x1,75x115

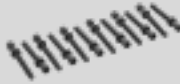

914.991
074 103 483 B



915.017
028 103 533
4x



FE













915.009
028 103 532 A
4x



FE



			<p>a) </p> <p>b) </p>	<p>K: </p> <p>N: </p>	
<p>VAS 730.130 FPM 553.190 026 109 675 FPM 10x</p>	<p>815.187 028 129 589 B 5x</p> 	<p>915.238 074 129 717</p> 	<p>b) 878.070 N 906 606 01 incl. 115.100 M 14x1,5x16</p> <p>b) 115.100 N 013 849.2 CU A 14x20x1,5</p>	<p>K:← 294.357 069 115 147 E ASW RD FPM/ACM 35x48x10</p> <p>K:← 475.961 054 115 147 B ASW RD FPM 35x48x10</p> <p>K:→ 342.093 068 103 051 P ASW LD FPM 85x105x11</p> <p>K:→ 804.850 028 103 171 K SP LD PTFE/ACM 85</p> <p>K:→ 829.056 068 198 171 ASW LD FPM 85x105x11</p> <p>N:← 325.155 068 103 085 E ASW WD FPM/ACM 32x47x10 2x</p>	

AUDI

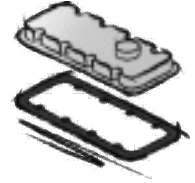
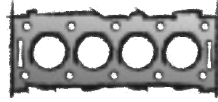
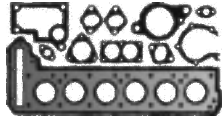

AFM
6 Cyl. **2393 ccm**
Cyl. 81,0 Ø

A4
07/1995 → 07/1997

A6
07/1995 → 12/1997

ES⊕ **184.050**
078 198 012 A
2x

A4 8D2/8D5
8D-T-076 001→

A6 4A2/4A5/4B2/4B5
4A-T-029 513→

CS* **670.740**
078 198 011 A
A4 8D2/8D5
→8D-V 205 000

A6 4A2/4A5/4B2/4B5
CS* **539.200**
A4 8D2/8D5
8D-V-205 001→

403.741
078 103 383 E
2x

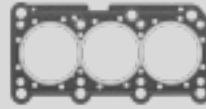

ZKS **804.250**
078 103 385 F (8x)
M 11x1,5x137
2x

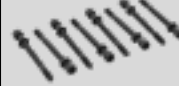

215.660
078 103 483 L
2x

A4 8D2/8D5
→8D-T-076 000

A6 4A2/4A5/4B2/4B5
→4A-T-029 512









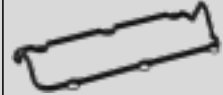





406.040
078 103 483 J
2x

A4 8D2/8D5
8D-T-076 001→

A6 4A2/4A5/4B2/4B5



			<p>a) </p> <p>b) </p>	<p>K: </p> <p>N: </p>	
<p>VAS 825.050 FPM 701.289 027 109 675 FPM 12x</p>	<p>632.690 078 129 589 2x</p> 	<p>632.700 078 129 717 A 2x</p> 	<p>a) 030.793 Dirko HT A4 8D2/8D5 8D-V 205 001→</p> <p>a) 921.107 078 103 609 F ↑ A4 8D2/8D5 →8D-V 205 000</p> <hr/> <p>A6 4A2/4A5/4B2/4B5</p>  <p>a) 921.093 078 103 609 G A4 8D2/8D5 A6 4A2/4A5/4B2/4B5 →8D-V 205 000</p>  <p>a) 467.762 078 103 610 E A4 8D2/8D5 8D-V 205 001→</p>  <p>b) 589.680 059 103 193 M 26x1,5x16 →8D-S-130 000</p> <p>b) 878.080 incl. 133.051 059 103 193 M 26x1,5x16 →8D-S-130 000</p> <p>b) 878.070 N 906 606 01 incl. 115.100 M 14x1,5x16 8D-S-130 001→</p> <p>b) 133.051 N 043 854.1 CU A 26x31x2 →8D-S-130 000</p> <p>b) 115.100 N 013 849.2 CU A 14x20x1,5 8D-S-130 001→</p>	<p>K:← 294.357 069 115 147 E ASW RD FPM/ACM 35x48x10</p> <p>K:← 475.961 054 115 147 B ASW RD FPM 35x48x10</p> <p>K:→ 342.093 068 103 051 P ASW LD FPM 85x105x11</p> <p>K:→ 829.056 068 198 171 ASW LD FPM 85x105x11</p> <p>N:← 325.155 068 103 085 E ASW WD FPM/ACM 32x47x10</p>	

AUDI

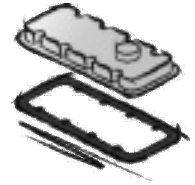
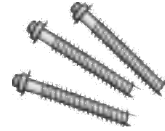
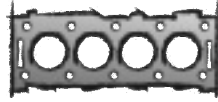
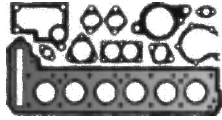

ALW **APC**
ARN **ASM**

6 Cyl. **2393 ccm**
Cyl. 81,0 Ø

A6
02/1997 → 01/2005

ES **074.400 ●**
078 198 012 D
→4B-W-150 000
2x

ES **470.660**
078 198 012 G
4B-W-150 001→
2x

CS* **539.200**
SZ **863.590**
058 198 217



212.410
078 103 383 K
1,40 mm $\frac{+}{-}$ 83,5 Ø
2x



ZKS **130.850**
078 103 385 K (8x)
M 11x1,5x133
2x



ZKHS **040.050**
078 198 025
2x





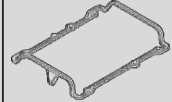









413.830
078 103 484 C
2x



413.860
078 103 483 M
2x



			<p>a) </p> <p>b) </p>	<p>K: </p> <p>N: </p>	
<p>VAS 057.070 FPM 724.590 036 109 675 A FPM 30x</p>	<p>632.760 078 253 039 C →4B-W-150 000 2x </p> <p>433.250 078 253 039 G 4B-W-150 001→ 2x </p>	<p>413.900 078 129 717 J 2x </p>	<p>a) 030.793 Dirko HT</p> <p>a) 467.762 078 103 610 E →4B-X-080 000 </p> <p>b) 567.640 N 908 132 01 M 14x1,5x22</p>	<p>K:← 155.560 038 103 085 E ASW RD PTFE/ACM 35x48x10</p> <p>K:← 294.357 069 115 147 E ASW RD FPM/ACM 35x48x10</p> <p>K:← 475.961 054 115 147 B ASW RD FPM 35x48x10</p> <p>K:→ 342.093 068 103 051 P ASW LD FPM 85x105x11</p> <p>K:→ 728.880 078 103 051 G 070 103 051 A AW/BS LD PTFE/ACM 85x105x12</p> <p>K:→ 829.056 068 198 171 ASW LD FPM 85x105x11</p> <p>N:← 129.780 038 103 085 C ASW RD PTFE/ACM 32x47x10 3x</p> <p>N:← 325.155 068 103 085 E ASW WD FPM/ACM 32x47x10 4x</p> <p>N:→ 326.470 028 103 086 A ASW LD PTFE/ACM 32x47x10 1x</p> <p>N:→ 798.040 028 103 086 C ASW OF LD FPM 32x47x10 1x</p>	

AUDI

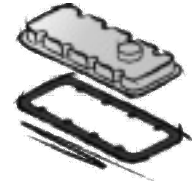
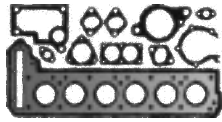

AMM
6 Cyl. **2393 ccm**
Cyl. 81,0 Ø

A4
08/1997 → 12/2005
A6
02/1997 → 01/2005

ES **470.660**
078 198 012 G
2x
CS* **539.200**
SZ **863.590**
058 198 217
2x



212.410
078 103 383 K
1,40 mm \pm 83,5 Ø
2x



ZKS **130.850**
078 103 385 K (8x)
M 11x1,5x133
2x



ZKHS **040.050**
078 198 025
2x





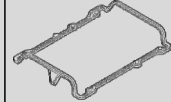







413.830
078 103 484 C
2x



413.860
078 103 483 M
2x



			<p>a) </p> <p>b) </p>	<p>K: </p> <p>N: </p>	
<p>VAS 057.070 FPM 724.590 036 109 675 A FPM 30x</p>	<p>433.250 078 253 039 G 2x </p>	<p>413.900 078 129 717 J 2x </p>	<p>a) 030.793 Dirko HT</p> <p>b) 567.640 N 908 132 01 M 14x1,5x22</p>	<p>K:← 155.560 038 103 085 E ASW RD PTFE/ACM 35x48x10</p> <p>K:← 294.357 069 115 147 E ASW RD FPM/ACM 35x48x10</p> <p>K:← 475.961 054 115 147 B ASW RD FPM 35x48x10</p> <p>K:→ 728.880 078 103 051 G 070 103 051 A AW/BS LD PTFE/ACM 85x105x12</p> <p>N:← 129.780 038 103 085 C ASW RD PTFE/ACM 32x47x10 3x</p> <p>N:← 325.155 068 103 085 E ASW WD FPM/ACM 32x47x10 4x</p> <p>N:→ 326.470 028 103 086 A ASW LD PTFE/ACM 32x47x10 1x</p> <p>N:→ 798.040 028 103 086 C ASW OF LD FPM 32x47x10 1x</p>	

AUDI

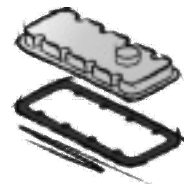
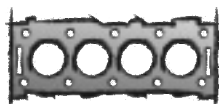
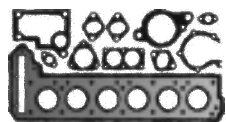

AGA
ALF
APS
ARJ

AJG
AML
APZ

6 Cyl. **2393 ccm**
Cyl. 81,0 Ø

A4
03/1997 → 09/2001

A6
02/1997 → 01/2005

ES **074.400 ●**
078 198 012 D
2x

A4 8D2/8D5
→8D-W-180 000

A6 4A2/4A5/4B2/4B5
→4B-W-150 000

ES **470.660**
078 198 012 G
2x

A4 8D2/8D5
8D-W-180 001→

A6 4A2/4A5/4B2/4B5
4B-W-150 001→

CS* **539.200**

SZ **863.590**
058 198 217
2x



212.410
078 103 383 K
1,40 mm $\frac{3}{4}$ 83,5 Ø
2x



ZKS **130.850**
078 103 385 K (8x)
M 11x1,5x133
2x



ZKHS **040.050**
078 198 025
2x



413.830
078 103 484 C
2x



413.860
078 103 483 M
2x



BDV
6 Cyl. **2393 ccm**
Cyl. 81,0 Ø

A4
09/2001 → 12/2005

A6
08/2001 → 01/2005

ES **470.660**
078 198 012 G

CS* **539.200**

SZ **863.590**
058 198 217
2x



212.410
078 103 383 K
1,40 mm $\frac{3}{4}$ 83,5 Ø
2x



ZKS **130.850**
078 103 385 K (8x)
M 11x1,5x133
2x



ZKHS **040.050**
078 198 025
2x

















413.830
078 103 484 C
2x



413.860
078 103 483 M
2x



			<p>a) </p> <p>b) </p>	<p>K: </p> <p>N: </p>	
<p>VAS 057.070 FPM 724.590 036 109 675 A FPM 30x</p>	<p>632.760 078 253 039 C 2x</p> <hr/> <p>A4 8D2/8D5 →8D-W-180 000</p> <hr/> <p>A6 4A2/4A5/4B2/4B5 →4B-W-150 000</p>  <p>433.250 078 253 039 G 2x</p> <hr/> <p>A4 8D2/8D5 8D-W-180 001→</p> <hr/> <p>A6 4A2/4A5/4B2/4B5 4B-W-150 001→</p> 	<p>413.900 078 129 717 J 2x</p> 	<p>a) 030.793 Dirko HT</p> <p>a) 467.762 078 103 610 E A6 4A2/4A5/4B2/4B5 A4 8D2/8D5 →4B-X-080 000 →8D-X-199 999</p>  <p>b) 567.640 N 908 132 01 M 14x1,5x22</p>	<p>K:← 155.560 038 103 085 E ASW RD PTFE/ACM 35x48x10</p> <p>K:← 294.357 069 115 147 E ASW RD FPM/ACM 35x48x10</p> <p>K:← 475.961 054 115 147 B ASW RD FPM 35x48x10</p> <p>K:→ 342.093 068 103 051 P ASW LD FPM 85x105x11</p> <p>K:→ 728.880 078 103 051 G 070 103 051 A AW/BS LD PTFE/ACM 85x105x12</p> <p>K:→ 829.056 068 198 171 ASW LD FPM 85x105x11</p> <p>N:← 129.780 038 103 085 C ASW RD PTFE/ACM 32x47x10 3x</p> <p>N:← 325.155 068 103 085 E ASW WD FPM/ACM 32x47x10 4x</p> <p>N:→ 326.470 028 103 086 A ASW LD PTFE/ACM 32x47x10 1x</p> <p>N:→ 798.040 028 103 086 C ASW OF LD FPM 32x47x10 1x</p>	
<p>VAS 057.070 FPM 724.590 036 109 675 A FPM 30x</p>	<p>433.250 078 253 039 G 2x</p> 	<p>413.900 078 129 717 J 2x</p> 	<p>a) 030.793 Dirko HT</p> <p>b) 567.640 N 908 132 01 M 14x1,5x22</p>	<p>K:← 155.560 038 103 085 E ASW RD PTFE/ACM 35x48x10</p> <p>K:→ 728.880 078 103 051 G 070 103 051 A AW/BS LD PTFE/ACM 85x105x12</p> <p>N:← 129.780 038 103 085 C ASW RD PTFE/ACM 32x47x10 3x</p> <p>N:← 325.155 068 103 085 E ASW WD FPM/ACM 32x47x10 4x</p> <p>N:→ 326.470 028 103 086 A ASW LD PTFE/ACM 32x47x10 1x</p> <p>N:→ 798.040 028 103 086 C ASW OF LD FPM 32x47x10 1x</p>	

AUDI



BDW
6 Cyl. **2393 ccm**
Cyl. 81,0 Ø

A6
05/2004 → 10/2008

ES⊕ **249.570**
CS* **244.710**

715.830
06E 103 148 P
82,5 Ø
Cyl. 1-3

715.840
06E 103 149 P
82,5 Ø
Cyl. 4-6

ZKS 325.040
06E 103 385 E (8x)
M 10x1,5x172
2x



461.682
EL-Liq 74
↓
725.860
06E 103 483 G
Cyl. 4-6

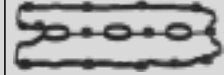

725.870
06E 103 484 G
Cyl. 1-3

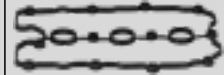

720.220
06E 103 649 E
↓ Cyl. 1-3



720.230
06E 103 650 A
↓ Cyl. 4-6



1T
ABP
5 Cyl. **2461 ccm**
Cyl. 81,0 Ø

100 TDI
01/1990 → 07/1994

ES⊕ **627.690**
046 198 012 A

CS* **917.710**
046 198 011



235.421
074 103 383 AJ
0,800 mm
→
0,900 mm
1,53 mm ± 82 Ø
1 ⊗

235.381
074 103 383 AH
0,900 mm
→
1,000 mm
1,57 mm ± 82 Ø
2 ⊗

230.521
074 103 383 AG
1,000 mm
→
1,100 mm
1,61 mm ± 82 Ø
3 ⊗

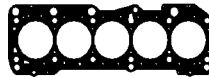



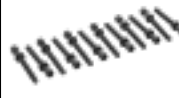



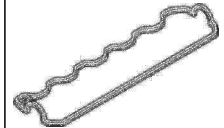

















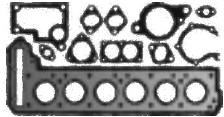
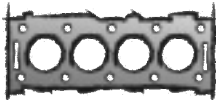

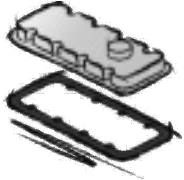



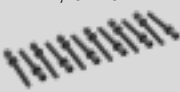

ZKS 819.875
068 103 384 A (12x)
M 12x1,75x115







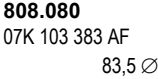









627.160
046 103 483 A



			<p>a) </p> <p>b) </p>	<p>K: </p> <p>N: </p>	
<p>VAS 235.650 FPM 724.590 036 109 675 A FPM 24x</p>	<p>724.250 06E 253 039 C 2x </p>	<p>232.910 06E 198 717 6x </p>	<p>a) 030.793 Dirko HT</p> <p>b) 567.640 N 908 132 01 M 14x1,5x22 →4F-7-047 000</p> <p>b) 982.340 N 016 027 6 incl. 813.036 M 14x1,5x12 4F-7-047 001→</p> <p>b) 591.840 N 013 815.8 Metal C 14x20x2 4F-7-047 001→</p> <p>b) 813.036 N 013 815.6 CU C 14x20x2 4F-7-047 001→</p>	<p>K:← 728.550 06E 103 153 E SP RD PTFE 45x60</p> <p>K:→ 026.790 079 103 051 F ASW LD PTFE/FPM 85x105x8,8</p>	
<p>VAS 730.130 FPM 553.190 026 109 675 FPM 10x</p>	<p>815.187 028 129 589 B 5x </p>	<p>627.350 046 129 717 A </p>	<p>a) 107.256 054 103 609 </p> <p>b) 878.070 N 906 606 01 incl. 115.100 M 14x1,5x16</p> <p>b) 115.100 N 013 849.2 CU A 14x20x1,5</p>	<p>K:← 294.357 069 115 147 E ASW RD FPM/ACM 35x48x10</p> <p>K:← 475.961 054 115 147 B ASW RD FPM 35x48x10</p> <p>K:→ 342.093 068 103 051 P ASW LD FPM 85x105x11</p> <p>K:→ 804.850 028 103 171 K SP LD PTFE/ACM 85</p> <p>K:→ 829.056 068 198 171 ASW LD FPM 85x105x11</p> <p>N:← 325.155 068 103 085 E ASW WD FPM/ACM 32x47x10 2x</p>	

AUDI 				
AAT AEL 5 Cyl. 2461 ccm Cyl. 81,0 Ø 100 TDI 12/1990 → 07/1994 A6 TDI 06/1994 → 12/1997	ES⊕ 627.690 046 198 012 A  CS* 627.580	235.421 074 103 383 AJ  0,800 mm → 0,900 mm 1,53 mm $\frac{\pm}{\text{mm}}$ 82 Ø 1 ⊗ 235.381 074 103 383 AH  0,900 mm → 1,000 mm 1,57 mm $\frac{\pm}{\text{mm}}$ 82 Ø 2 ⊗ 230.521 074 103 383 AG  1,000 mm → 1,100 mm 1,61 mm $\frac{\pm}{\text{mm}}$ 82 Ø 3 ⊗	ZKS 819.875 068 103 384 A (12x) M 12x1,75x115 	627.160 046 103 483 A 
CEPA CEPB 5 Cyl. 2480 ccm Cyl. 82,5 Ø A3 RS3 01/2011 → 12/2012 TT 07/2009 → 06/2014	ES⊕ 509.820 CS* 373.960 SZ 493.870 OKS 242.390 	493.062 07K 103 383 L 0,90 mm $\frac{\pm}{\text{mm}}$ 83,3 Ø 	ZKS 005.610 06D 103 385 D (12x) M 10x1,5x117 	509.810 07K 103 483 A  461.682 EL-Liq 74 ↓
CTSA CZGA CZGB 5 Cyl. 2480 ccm Cyl. 82,5 Ø A3 RS3 03/2015 → Q3 RS 05/2013 → 10/2018	ES⊕ 509.820 CS* 373.960 SZ 493.870 OKS 242.390 	493.062 07K 103 383 L 0,90 mm $\frac{\pm}{\text{mm}}$ 83,3 Ø 	ZKS 005.610 06D 103 385 D (12x) M 10x1,5x117 	509.810 07K 103 483 A  461.682 EL-Liq 74 ↓
DAZA DNWA DNWC 5 Cyl. 2480 ccm Cyl. 82,5 Ø A3 RS3 04/2017 → Q3 10/2019 → TT 10/2016 →		808.080 07K 103 383 AF 83,5 Ø 	ZKS 824.990 WHT 007 848 D (12x) M 10x1,5x150 	461.682 EL-Liq 74

AUDI

			<p>a) </p> <p>b) </p>	<p>K: </p> <p>N: </p>	
<p>VAS 730.130 FPM 553.190 026 109 675 FPM 10x</p>	<p>815.187 028 129 589 B 5x</p> 	<p>915.238 074 129 717</p> 	<p>a) 107.256 054 103 609</p>  <p>b) 878.070 N 906 606 01 incl. 115.100 M 14x1,5x16</p> <p>b) 115.100 N 013 849.2 CU A 14x20x1,5</p>	<p>K:← 294.357 069 115 147 E ASW RD FPM/ACM 35x48x10</p> <p>K:← 475.961 054 115 147 B ASW RD FPM 35x48x10</p> <p>K:→ 342.093 068 103 051 P ASW LD FPM 85x105x11</p> <p>K:→ 804.850 028 103 171 K SP LD PTFE/ACM 85</p> <p>K:→ 829.056 068 198 171 ASW LD FPM 85x105x11</p> <p>N:← 325.155 068 103 085 E ASW WD FPM/ACM 32x47x10 2x</p>	
<p>VAS 235.620 FPM 724.590 036 109 675 A FPM 20x</p>	<p>416.300 07K 253 039 D</p> 		<p>a) 030.793 Dirko HT</p> <p>b) 567.640 N 908 132 01 M 14x1,5x22</p>	<p>K:← 279.810 07K 103 151 C SP RD PTFE/FPM 55</p> <p>K:→ 331.330 059 103 051 K ASW OF LD FPM 85x105x8</p> <p>K:→ 728.880 078 103 051 G 070 103 051 A AW/BS LD PTFE/ACM 85x105x12</p>	<p>TLS 481.340</p>
<p>724.590 036 109 675 A FPM E 10x 797.560 06L 09 675 C FPM A 10x</p>	<p>416.300 07K 253 039 D</p> 	<p>416.100 07K 133 379 A</p> 	<p>a) 030.793 Dirko HT</p> <p>b) 567.640 N 908 132 01 M 14x1,5x22</p>	<p>K:← 279.810 07K 103 151 C SP RD PTFE/FPM 55</p> <p>K:→ 331.330 059 103 051 K ASW OF LD FPM 85x105x8</p> <p>K:→ 728.880 078 103 051 G 070 103 051 A AW/BS LD PTFE/ACM 85x105x12</p>	<p>TLS 481.340</p>
<p>VAS 562.260 FPM A 724.590 036 109 675 A FPM E 10x</p>			<p>a) 030.793 Dirko HT</p> <p>b) 858.050 N 911 679 01 incl. 591.840 M 14x1,5x15</p> <p>b) 243.205 N 013 849.3 AL A 14x20x1,5</p> <p>b) 591.840 N 013 815.8 Metal C 14x20x2</p>		<p>TLS 481.340</p>

AUDI

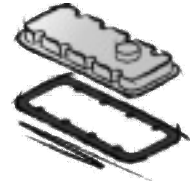
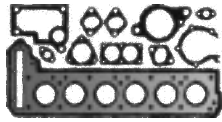



AFB
AKN

6 Cyl. **2496 ccm**
Cyl. 78,3 Ø

A4 TDI
09/1997 → 09/2001
A6 TDI
07/1997 → 01/2005
A8 TDI
01/1997 → 04/2000

ES⊕ **439.041**
2x

CS* **295.500**

447.472
059 103 383 BQ
 0,390 mm
→
0,490 mm
1,10 mm $\frac{\pm}{\pm}$ 79 Ø
1 ▽
2x
447.482
059 103 383 BR
 0,490 mm
→
0,540 mm
1,15 mm $\frac{\pm}{\pm}$ 79 Ø
2 ▽
2x
447.492
059 103 383 BS
 0,540 mm
→
0,650 mm
1,20 mm $\frac{\pm}{\pm}$ 79 Ø
3 ▽
2x

ZKS **008.860**
059 103 384 (8x)
M 12x1,5x155
2x



ZKHS **389.420**
059 198 025
2x

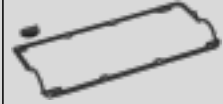



AKE
AYM

6 Cyl. **2496 ccm**
Cyl. 78,3 Ø

A4 TDI
11/2000 → 12/2004
A6 TDI
02/2000 → 01/2005
A8 TDI
09/2000 → 09/2002
Allroad TDI
05/2000 → 08/2005

ES⊕ **439.041**
2x

CS* **295.500**

















447.472
059 103 383 BQ
 0,390 mm
→
0,490 mm
1,10 mm $\frac{\pm}{\pm}$ 79 Ø
1 ▽
2x
447.482
059 103 383 BR
 0,490 mm
→
0,540 mm
1,15 mm $\frac{\pm}{\pm}$ 79 Ø
2 ▽
2x
447.492
059 103 383 BS
 0,540 mm
→
0,650 mm
1,20 mm $\frac{\pm}{\pm}$ 79 Ø
3 ▽
2x

ZKS **008.860**
059 103 384 (8x)
M 12x1,5x155
2x

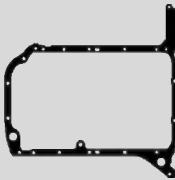

ZKHS **389.420**
059 198 025
2x



			<p>a) </p> <p>b) </p>	<p>K: </p> <p>N: </p>	
<p>VAS 235.650 FPM 724.590 036 109 675 A FPM 24x</p>	<p>231.240 059 253 039 B 6x </p>	<p>422.890 059 129 717 G 2x </p>	<p>a) 030.793 Dirko HT a) 451.790 059 103 609 J ↑ →8D-W-210 000 →4D-W-014 500 →4B-W-175 000  a) 422.880 059 103 610 B  b) 243.205 N 013 849.3 AL A 14x20x1,5</p>	<p>K:← 475.961 054 115 147 B ASW RD FPM 35x48x10 K:→ 728.880 078 103 051 G 070 103 051 A AW/BS LD PTFE/ACM 85x105x12 K:→ 750.330 059 103 171 D SP LD PTFE/ACM 85x15 N:← 325.155 068 103 085 E ASW WD FPM/ACM 32x47x10 2x</p>	<p>TLS 704.050 </p>
<p>VAS 235.650 FPM 724.590 036 109 675 A FPM 24x</p>	<p>231.240 059 253 039 B 6x </p>	<p>422.890 059 129 717 G 2x </p>	<p>a) 030.793 Dirko HT a) 422.880 059 103 610 B  b) 243.205 N 013 849.3 AL A 14x20x1,5</p>	<p>K:← 475.961 054 115 147 B ASW RD FPM 35x48x10 K:→ 728.880 078 103 051 G 070 103 051 A AW/BS LD PTFE/ACM 85x105x12 K:→ 750.330 059 103 171 D SP LD PTFE/ACM 85x15 N:← 325.155 068 103 085 E ASW WD FPM/ACM 32x47x10 2x</p>	<p>TLS 704.050 </p>

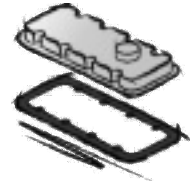

AUDI



BAU BND **BDH**
6 Cyl. **2496 ccm**
Cyl. 78,3 Ø

A4 TDI
11/2000 → 12/2004
A6 TDI
02/2000 → 01/2005
Allroad TDI
05/2000 → 08/2005

ES⊕ **439.041**
2x

CS* **295.500**

447.472
059 103 383 BQ
 0,390 mm
→
0,490 mm
1,10 mm $\frac{1}{2}$ 79 Ø
1 ▽
2x
447.482
059 103 383 BR
 0,490 mm
→
0,540 mm
1,15 mm $\frac{1}{2}$ 79 Ø
2 ▽
2x
447.492
059 103 383 BS
 0,540 mm
→
0,650 mm
1,20 mm $\frac{1}{2}$ 79 Ø
3 ▽
2x



ZKS 130.110
057 103 384 A (8x)
M 12x1,5x159
2x



ZKHS 389.420
059 198 025
2x

BCZ BDG
6 Cyl. **2496 ccm**
Cyl. 78,3 Ø















A4 TDI
07/2002 → 05/2006
A6 TDI
07/2002 → 01/2005
Allroad TDI
05/2003 → 08/2005









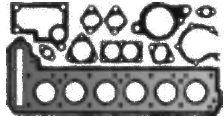
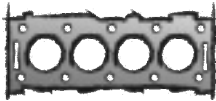

ES⊕ **439.041**
2x

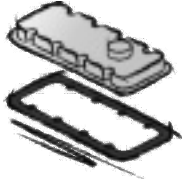
CS* **295.500**

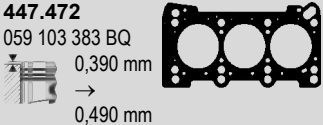
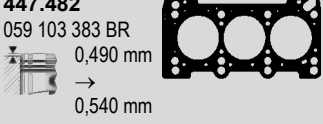
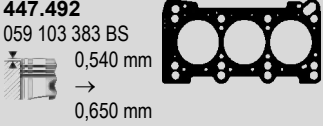
447.472
059 103 383 BQ
 0,390 mm
→
0,490 mm
1,10 mm $\frac{1}{2}$ 79 Ø
1 ▽
2x
447.482
059 103 383 BR
 0,490 mm
→
0,540 mm
1,15 mm $\frac{1}{2}$ 79 Ø
2 ▽
2x
447.492
059 103 383 BS
 0,540 mm
→
0,650 mm
1,20 mm $\frac{1}{2}$ 79 Ø
3 ▽
2x

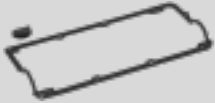



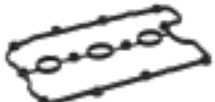







ZKS 130.110
057 103 384 A (8x)
M 12x1,5x159
2x

ZKHS 389.420
059 198 025
2x



			<p>a) </p> <p>b) </p>	<p>K: </p> <p>N: </p>	
<p>VAS 235.650 FPM 724.590 036 109 675 A FPM 24x</p>	<p>231.240 059 253 039 B 6x </p>	<p>422.890 059 129 717 G 2x </p>	<p>a) 030.793 Dirko HT a) 422.880 059 103 610 B </p> <p>b) 243.205 N 013 849.3 AL A 14x20x1,5</p>	<p>K:← 475.961 054 115 147 B ASW RD FPM 35x48x10 K:→ 728.880 078 103 051 G 070 103 051 A AW/BS LD PTFE/ACM 85x105x12 K:→ 750.330 059 103 171 D SP LD PTFE/ACM 85x15 N:← 325.155 068 103 085 E ASW WD FPM/ACM 32x47x10 2x</p>	<p>TLS 704.050 </p>
<p>VAS 235.650 FPM 724.590 036 109 675 A FPM 24x</p>	<p>231.240 059 253 039 B 6x </p>	<p>422.890 059 129 717 G 2x </p>	<p>a) 030.793 Dirko HT b) 243.205 N 013 849.3 AL A 14x20x1,5</p>	<p>K:← 475.961 054 115 147 B ASW RD FPM 35x48x10 K:→ 728.880 078 103 051 G 070 103 051 A AW/BS LD PTFE/ACM 85x105x12 K:→ 750.330 059 103 171 D SP LD PTFE/ACM 85x15 N:← 325.155 068 103 085 E ASW WD FPM/ACM 32x47x10 2x</p>	<p>TLS 704.050 </p>

<p>AUDI</p> 				
<p>BFC</p> <p>6 Cyl. 2496 ccm Cyl. 78,3 Ø</p> <p>A4 TDI 07/2002 → 12/2005</p> <p>A6 TDI 07/2002 → 01/2005</p>	<p>ES⊕ 439.041 2x</p>  <p>CS* 295.500</p>	<p>447.472 059 103 383 BQ</p>  <p>0,390 mm → 0,490 mm</p> <p>1,10 mm $\frac{\pm}{\pm}$ 79 Ø 1 ▽ 2x</p> <p>447.482 059 103 383 BR</p>  <p>0,490 mm → 0,540 mm</p> <p>1,15 mm $\frac{\pm}{\pm}$ 79 Ø 2 ▽ 2x</p> <p>447.492 059 103 383 BS</p>  <p>0,540 mm → 0,650 mm</p> <p>1,20 mm $\frac{\pm}{\pm}$ 79 Ø 3 ▽ 2x</p>	<p>ZKS 008.860 059 103 384 (8x) M 12x1,5x155 2x</p> 	<p>ZKHS 389.420 059 198 025 2x</p> 
<p>CLXA CLXB CPAA CVBA</p> <p>6 Cyl. 2498 ccm Cyl. 80,2 Ø</p> <p>A7 09/2012 → 03/2015</p> <p>A8 07/2012 → 06/2016</p>	<p>ES⊕ 589.650 CS* 783.930</p>	<p>589.600 06E 103 148 AJ 81 Ø</p> <p>Cyl. 1-3</p> <p>589.660 06E 103 149 AJ 81 Ø</p> <p>Cyl. 4-6</p> 	<p>ZKS 223.890 WHT 005 739 (8x) M 10x1,5x170 2x</p> 	<p>461.682 EL-Liq 74 ↓ 429.910 06E 103 483 Q Cyl. 4-6</p>  <p>429.980 06E 103 484 P Cyl. 1-3</p> 

AUDI

			<p>a) </p> <p>b) </p>	<p>K: </p> <p>N: </p>	
<p>VAS 235.650 FPM 724.590 036 109 675 A FPM 24x</p>	<p>231.240 059 253 039 B 6x </p>	<p>422.890 059 129 717 G 2x </p>	<p>a) 030.793 Dirko HT</p> <p>b) 243.205 N 013 849.3 AL A 14x20x1,5</p>	<p>K:← 475.961 054 115 147 B ASW RD FPM 35x48x10</p> <p>K:→ 728.880 078 103 051 G 070 103 051 A AW/BS LD PTFE/ACM 85x105x12</p> <p>K:→ 750.330 059 103 171 D SP LD PTFE/ACM 85x15</p> <p>N:← 325.155 068 103 085 E ASW WD FPM/ACM 32x47x10 2x</p>	<p>TLS 704.050 </p>
<p>VAS 235.650 FPM 724.590 036 109 675 A FPM 24x</p>	<p>724.250 06E 253 039 C 2x </p>	<p>232.910 06E 198 717 6x </p>	<p>a) 030.793 Dirko HT</p> <p>b) 982.340 N 016 027 6 incl. 813.036 M 14x1,5x12</p> <p>b) 591.840 N 013 815.8 Metal C 14x20x2</p> <p>b) 813.036 N 013 815.6 CU C 14x20x2</p>	<p>K:← 728.550 06E 103 153 E SP RD PTFE 45x60</p> <p>K:→ 026.790 079 103 051 F ASW LD PTFE/FPM 85x105x8,8</p>	

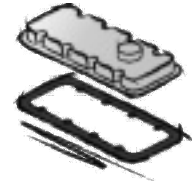
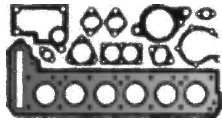
AUDI



ABC
6 Cyl. **2598 ccm**
Cyl. 82,5 Ø

100
03/1992 → 07/1994

80
06/1992 → 01/1996

A4
01/1995 → 09/2001

A6
06/1994 → 12/1997

Cabrio
06/1993 → 08/2000

Coupé
08/1992 → 12/1996

ES⊕ **184.050**
078 198 012 A
Coupé B3
8B-T-002 001→

Cabrio B3
8G-T-004 319→

A4 8D2/8D5
8D-T-076 001→

A6 4A2/4A5
4A-T-029 513→

ES⊕ **215.970**
078 198 012
Coupé B3
→8B-S-000 544

Cabrio B3
→8G-S-001 302

80 B4
→8C-S-025 820

A6 4A2/4A5
→4A-S-026 714

CS* **539.200**
Cabrio B3
8G-W-000 106→

CS* **632.740**
A4 8D2/8D5
8D-V-205 001→
078 198 011
Coupé B3
→8B-S-000 544

Cabrio B3
→8G-S-001 302

80 B4
→8C-S-025 820

CS* **670.740**
A6 4A2/4A5
→4A-S-026 714
078 198 011 A
Coupé B3
8B-S-000 545→

Cabrio B3
8G-S-001 303→
→8G-W-000 105

80 B4
8C-S-025 821→

A4 8D2/8D5
→8D-V-205 000

A6 4A2/4A5
4A-S-026 715→

403.741
078 103 383 E
2x

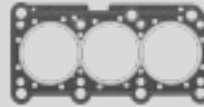

ZKS **804.250**
078 103 385 F (8x)
M 11x1,5x137
2x

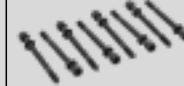

215.660
078 103 483 L
2x

Coupé B3
→8B-T-002 000

Cabrio B3
→8G-T-004 318

80 B4

A4 8D2/8D5
→8D-T-076 000

A6 4A2/4A5
→4A-T-029 512



406.040
078 103 483 J
2x









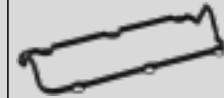



Coupé B3
8B-T-002 001→

Cabrio B3
8G-T-004 319→

A4 8D2/8D5
8D-T-076 001→

A6 4A2/4A5
4A-T-029 513→

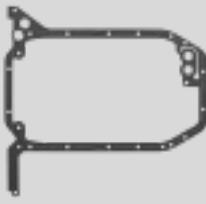

			<p>a) </p> <p>b) </p>	<p>K: </p> <p>N: </p>	
<p>VAS 825.050 FPM Coupé B3 8B-S-000 545→</p> <hr/> <p>Cabrio B3 8G-S-001 303→</p> <hr/> <p>80 B4 8C-S-025 821→</p> <hr/> <p>A4 8D2/8D5</p> <hr/> <p>A6 4A2/4A5 4A-S-026 715→</p> <p>553.190 026 109 675 FPM E A 12x</p> <hr/> <p>Coupé B3 →8B-S-000 544</p> <hr/> <p>Cabrio B3 →8G-S-001 302</p> <hr/> <p>80 B4 →8C-S-025 820</p> <hr/> <p>A6 4A2/4A5 →4A-S-026 714</p> <p>701.289 027 109 675 FPM E A 12x</p> <hr/> <p>Coupé B3 8B-S-000 545→</p> <hr/> <p>Cabrio B3 8G-S-001 303→</p> <hr/> <p>80 B4 8C-S-025 821→</p> <hr/> <p>A4 8D2/8D5</p> <hr/> <p>A6 4A2/4A5 4A-S-026 715→</p>	<p>632.690 078 129 589 2x</p> 	<p>632.700 078 129 717 A 2x</p> 	<p>a) 767.907 078 103 609 E ↑ Coupé B3 →8B-S-000 544</p> <hr/> <p>Cabrio B3 →8G-S-001 302</p> <hr/> <p>80 B4 →8C-S-025 820</p> <hr/> <p>A6 4A2/4A5 →4A-S-026 714</p>  <hr/> <p>a) 921.107 078 103 609 F ↑ Coupé B3 8B-S-000 545→</p> <hr/> <p>Cabrio B3 8G-S-001 303→ →8G-W-000 105</p> <hr/> <p>80 B4 8C-S-025 821→</p> <hr/> <p>A4 8D2/8D5 →8D-V-205 000</p> <hr/> <p>A6 4A2/4A5 4A-S-026 715→</p>  <hr/> <p>a) 030.793 Dirko HT ↑</p> <hr/> <p>Cabrio B3 8G-W-000 106→</p> <hr/> <p>A4 8D2/8D5 8D-V-205 001→</p> <p>a) 767.824 078 103 610 A 80 B4 A6 4A2/4A5 Cabrio B3 Coupé B3 →8B-S-000 544 →4A-S-026 714 →8G-S-001 302</p>	<p>K:← 294.357 069 115 147 E ASW RD FPM/ACM 35x48x10</p> <p>K:← 475.961 054 115 147 B ASW RD FPM 35x48x10</p> <p>K:→ 342.093 068 103 051 P ASW LD FPM 85x105x11</p> <p>K:→ 829.056 068 198 171 ASW LD FPM 85x105x11</p> <p>N:← 325.155 068 103 085 E ASW WD FPM/ACM 32x47x10 3x</p>	

AUDI

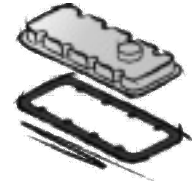
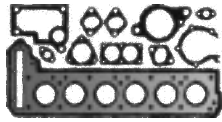

ABC
6 Cyl. **2598 ccm**
Cyl. 82,5 Ø

100
03/1992 → 07/1994

80
06/1992 → 01/1996

A4
01/1995 → 09/2001

A6
06/1994 → 12/1997

Cabrio
06/1993 → 08/2000

Coupé
08/1992 → 12/1996

ES⊕ **184.050**
078 198 012 A
Coupé B3
8B-T-002 001→

Cabrio B3
8G-T-004 319→

A4 8D2/8D5
8D-T-076 001→

A6 4A2/4A5
4A-T-029 513→

ES⊕ **215.970**
078 198 012
Coupé B3
→8B-S-000 544

Cabrio B3
→8G-S-001 302

80 B4
→8C-S-025 820

A6 4A2/4A5
→4A-S-026 714

CS* **539.200**
Cabrio B3
8G-W-000 106→

A4 8D2/8D5
8D-V-205 001→

CS* **632.740**
078 198 011
Coupé B3
→8B-S-000 544

Cabrio B3
→8G-S-001 302

80 B4
→8C-S-025 820

A6 4A2/4A5
→4A-S-026 714

CS* **670.740**
078 198 011 A
Coupé B3
8B-S-000 545→

Cabrio B3
8G-S-001 303→
→8G-W-000 105

80 B4
8C-S-025 821→

A4 8D2/8D5
→8D-V-205 000

A6 4A2/4A5
4A-S-026 715→

403.741
078 103 383 E
2x

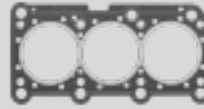

ZKS **804.250**
078 103 385 F (8x)
M 11x1,5x137
2x

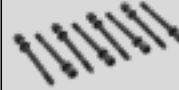

215.660
078 103 483 L
2x

Coupé B3
→8B-T-002 000

Cabrio B3
→8G-T-004 318

80 B4

A4 8D2/8D5
→8D-T-076 000

A6 4A2/4A5
→4A-T-029 512

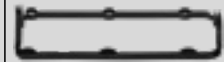

406.040
078 103 483 J
2x









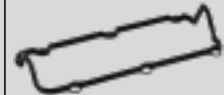



Coupé B3
8B-T-002 001→

Cabrio B3
8G-T-004 319→

A4 8D2/8D5
8D-T-076 001→

A6 4A2/4A5
4A-T-029 513→



			<p>a) </p> <p>b) </p>	<p>K: </p> <p>N: </p>	
<p>VAS 825.050 FPM Coupé B3 8B-S-000 545→</p> <hr/> <p>Cabrio B3 8G-S-001 303→</p> <hr/> <p>80 B4 8C-S-025 821→</p> <hr/> <p>A4 8D2/8D5</p> <hr/> <p>A6 4A2/4A5 4A-S-026 715→</p> <p>553.190 026 109 675 FPM E A 12x</p> <hr/> <p>Coupé B3 →8B-S-000 544</p> <hr/> <p>Cabrio B3 →8G-S-001 302</p> <hr/> <p>80 B4 →8C-S-025 820</p> <hr/> <p>A6 4A2/4A5 →4A-S-026 714</p> <p>701.289 027 109 675 FPM E A 12x</p> <hr/> <p>Coupé B3 8B-S-000 545→</p> <hr/> <p>Cabrio B3 8G-S-001 303→</p> <hr/> <p>80 B4 8C-S-025 821→</p> <hr/> <p>A4 8D2/8D5</p> <hr/> <p>A6 4A2/4A5 4A-S-026 715→</p>	<p>632.690 078 129 589 2x</p> 	<p>632.700 078 129 717 A 2x</p> 	<p>→8C-S-025 820</p>  <p>a) 921.093 078 103 609 G 80 B4 Cabrio B3 Coupé B3 A4 8D2/8D5 A6 4A2/4A5 8C-S-025 821→ 8G-S-001 303→ 8B-S-000 545→ 4A-S-026 715→ →8D-V-205 000</p>  <p>a) 467.762 078 103 610 E A4 8D2/8D5 Cabrio B3 8D-V-205 001→ 8G-W-000 106→</p>  <p>b) 589.680 059 103 193 M 26x1,5x16 →07/1995</p> <p>b) 878.080 incl. 133.051 059 103 193 M 26x1,5x16 →07/1995</p> <p>b) 878.070 N 906 606 01 incl. 115.100 M 14x1,5x16 08/1995→</p> <p>b) 133.051 N 043 854.1 CU A 26x31x2 →07/1995</p> <p>b) 115.100 N 013 849.2 CU A 14x20x1,5 08/1995→</p>	<p>K:← 294.357 069 115 147 E ASW RD FPM/ACM 35x48x10</p> <p>K:← 475.961 054 115 147 B ASW RD FPM 35x48x10</p> <p>K:→ 342.093 068 103 051 P ASW LD FPM 85x105x11</p> <p>K:→ 829.056 068 198 171 ASW LD FPM 85x105x11</p> <p>N:← 325.155 068 103 085 E ASW WD FPM/ACM 32x47x10 3x</p>	

AUDI

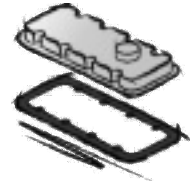

ACZ
6 Cyl. **2598 ccm**
Cyl. 82,5 Ø

100
07/1993 → 07/1994

A4
01/1996 → 07/1997

A6
06/1994 → 10/1997

ES⊕ **215.970**
078 198 012
A6 4A2/4A5
→4A-S-026 714

ES⊕ **184.050**
078 198 012 A
A4 8D2/8D5
8D-T-076 001→

A6 4A2/4A5
4A-T-029 513→

CS* **632.740**
078 198 011
A6 4A2/4A5
→4A-S-026 714

CS* **670.740**
078 198 011 A
A4 8D2/8D5
→8D-V-205 000

A6 4A2/4A5
4A-S-026 715→

CS* **539.200**
A4 8D2/8D5
8D-V-205 001→

403.741
078 103 383 E
2x

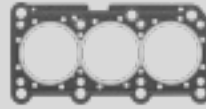

ZKS 804.250
078 103 385 F (8x)
M 11x1,5x137
2x

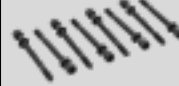

215.660
078 103 483 L
2x

A4 8D2/8D5
→8D-T-076 000

A6 4A2/4A5
→4A-T-029 512









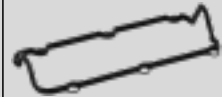





406.040
078 103 483 J
2x







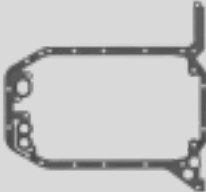

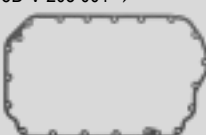

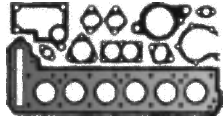
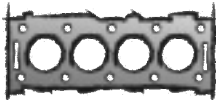

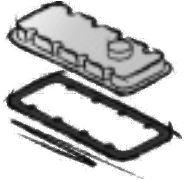
A4 8D2/8D5
8D-T-076 001→

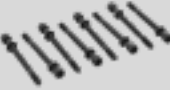

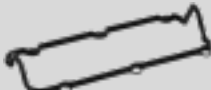











A6 4A2/4A5
4A-T-029 513→



AUDI

			<p>a) </p> <p>b) </p>	<p>K: </p> <p>N: </p>	
<p>VAS 825.050 FPM A4 8D2/8D5</p> <hr/> <p>A6 4A2/4A5 4A-S-026 715→</p> <p>553.190 026 109 675 FPM E A 12x</p> <hr/> <p>A6 4A2/4A5 →4A-S-026 714</p> <p>701.289 027 109 675 FPM E A 12x</p> <hr/> <p>A4 8D2/8D5</p> <hr/> <p>A6 4A2/4A5 4A-S-026 715→</p>	<p>632.690 078 129 589 2x</p> 	<p>632.700 078 129 717 A 2x</p> 	<p>a) 767.907 078 103 609 E ↑ A6 4A2/4A5 →4A-S-026 714</p>  <p>a) 921.107 078 103 609 F ↑ A4 8D2/8D5 →8D-V-205 000</p> <p>A6 4A2/4A5 4A-S-026 715→</p>  <p>a) 030.793 Dirko HT ↑</p> <p>A4 8D2/8D5 8D-V-205 001→</p> <p>a) 767.824 078 103 610 A A6 4A2/4A5 →4A-S-026 714</p>  <p>a) 921.093 078 103 609 G A4 8D2/8D5 A6 4A2/4A5 4A-S-026 715→ →8D-V-205 000</p>  <p>a) 467.762 078 103 610 E A4 8D2/8D5 8D-V-205 001→</p>  <p>b) 589.680</p>	<p>K:← 294.357 069 115 147 E ASW RD FPM/ACM 35x48x10</p> <p>K:← 475.961 054 115 147 B ASW RD FPM 35x48x10</p> <p>K:→ 342.093 068 103 051 P ASW LD FPM 85x105x11</p> <p>K:→ 829.056 068 198 171 ASW LD FPM 85x105x11</p> <p>N:← 325.155 068 103 085 E ASW WD FPM/ACM 32x47x10 3x</p>	

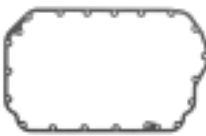
<p>AUDI</p> 				
<p>ACZ</p> <p>6 Cyl. 2598 ccm Cyl. 82,5 Ø</p> <p>100 07/1993 → 07/1994</p> <p>A4 01/1996 → 07/1997</p> <p>A6 06/1994 → 10/1997</p>	<p>ES⊕ 215.970 078 198 012 A6 4A2/4A5 →4A-S-026 714</p> <p>ES⊕ 184.050 078 198 012 A A4 8D2/8D5 8D-T-076 001→</p> <hr/> <p>A6 4A2/4A5 4A-T-029 513→</p> <p>CS* 632.740 078 198 011 A6 4A2/4A5 →4A-S-026 714</p> <p>CS* 670.740 078 198 011 A A4 8D2/8D5 →8D-V-205 000</p> <hr/> <p>A6 4A2/4A5 4A-S-026 715→</p> <p>CS* 539.200 A4 8D2/8D5 8D-V-205 001→</p>	<p>403.741 078 103 383 E 2x</p> 	<p>ZKS 804.250 078 103 385 F (8x) M 11x1,5x137 2x</p> 	<p>215.660 078 103 483 L 2x</p> <hr/> <p>A4 8D2/8D5 →8D-T-076 000</p> <hr/> <p>A6 4A2/4A5 →4A-T-029 512</p>  <p>406.040 078 103 483 J 2x</p> <hr/> <p>A4 8D2/8D5 8D-T-076 001→</p> <hr/> <p>A6 4A2/4A5 4A-T-029 513→</p> 
<p>AJK</p> <p>6 Cyl. 2671 ccm Cyl. 81,0 Ø</p> <p>A4 02/1999 → 09/2000</p> <p>A6 12/1997 → 01/2005</p>	<p>ES 212.440 078 198 012 E 2x</p> <p>CS* 539.200</p> <p>SZ 863.590 058 198 217 2x</p> 	<p>212.410 078 103 383 K 1,40 mm $\frac{+}{-}$ 83,5 Ø 2x</p> 	<p>ZKS 130.850 078 103 385 K (8x) M 11x1,5x133 2x</p> 	<p>ZKHS 040.050 078 198 025 2x</p>  <p>413.830 078 103 484 C 2x</p>  <p>413.860 078 103 483 M 2x</p> 

			<p>a) </p> <p>b) </p>	<p>K: </p> <p>N: </p>	
<p>VAS 825.050 FPM A4 8D2/8D5</p> <hr/> <p>A6 4A2/4A5 4A-S-026 715→</p> <p>553.190 026 109 675 FPM E A 12x</p> <hr/> <p>A6 4A2/4A5 →4A-S-026 714</p> <p>701.289 027 109 675 FPM E A 12x</p> <hr/> <p>A4 8D2/8D5</p> <hr/> <p>A6 4A2/4A5 4A-S-026 715→</p>	<p>632.690 078 129 589 2x</p> 	<p>632.700 078 129 717 A 2x</p> 	<p>059 103 193 M 26x1,5x16 →07/1995</p> <p>b) 878.080 incl. 133.051 059 103 193 M 26x1,5x16 →07/1995</p> <p>b) 878.070 N 906 606 01 incl. 115.100 M 14x1,5x16 08/1995→</p> <p>b) 133.051 N 043 854.1 CU A 26x31x2 →07/1995</p> <p>b) 115.100 N 013 849.2 CU A 14x20x1,5 08/1995→</p>	<p>K:← 294.357 069 115 147 E ASW RD FPM/ACM 35x48x10</p> <p>K:← 475.961 054 115 147 B ASW RD FPM 35x48x10</p> <p>K:→ 342.093 068 103 051 P ASW LD FPM 85x105x11</p> <p>K:→ 829.056 068 198 171 ASW LD FPM 85x105x11</p> <p>N:← 325.155 068 103 085 E ASW WD FPM/ACM 32x47x10 3x</p>	
<p>VAS 057.070 FPM</p> <p>724.590 036 109 675 A FPM 30x</p>	<p>433.250 078 253 039 G 2x</p> 	<p>433.301 078 129 717 N 2x</p> 	<p>a) 030.793 Dirko HT</p> <p>a) 467.762 078 103 610 E A6 4A2/4A5/4B2/4B5 A4 8D2/8D5 →4B-X-080 000 →8D-X-200 000</p>  <p>b) 567.640 N 908 132 01 M 14x1,5x22</p>	<p>K:← 155.560 038 103 085 E ASW RD PTFE/ACM 35x48x10</p> <p>K:← 294.357 069 115 147 E ASW RD FPM/ACM 35x48x10</p> <p>K:← 475.961 054 115 147 B ASW RD FPM 35x48x10</p> <p>K:→ 728.880 078 103 051 G 070 103 051 A AW/BS LD PTFE/ACM 85x105x12</p> <p>N:← 129.780 038 103 085 C ASW RD PTFE/ACM 32x47x10 3x</p> <p>N:← 325.155 068 103 085 E ASW WD FPM/ACM 32x47x10 4x</p> <p>N:→ 326.470 028 103 086 A ASW LD PTFE/ACM 32x47x10 1x</p> <p>N:→ 798.040 028 103 086 C ASW OF LD FPM 32x47x10 1x</p>	<p>TLS 305.890</p> 

AUDI

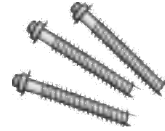
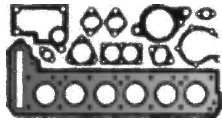

APB
6 Cyl. **2671 ccm**
Cyl. 81,0 Ø

A4
01/2001 → 12/2002

A4 S4
10/1997 → 12/2002

A6
05/2001 → 07/2004

Allroad
09/2000 → 08/2005

ES **212.440**
078 198 012 E
2x
CS* **539.200**
SZ **863.590**
058 198 217
2x



212.410
078 103 383 K
1,40 mm $\frac{+}{-}$ 83,5 Ø
2x



ZKS **130.850**
078 103 385 K (8x)
M 11x1,5x133
2x



ZKHS **040.050**
078 198 025
2x



413.830
078 103 484 C
2x

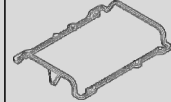

413.860
078 103 483 M
2x



ARE
BES
6 Cyl. **2671 ccm**
Cyl. 81,0 Ø

A6
08/2001 → 01/2005

Allroad
05/2000 → 08/2005

ES **212.440**
078 198 012 E
2x
SZ **863.590**
058 198 217
2x



212.410
078 103 383 K
1,40 mm $\frac{+}{-}$ 83,5 Ø
2x



ZKS **130.850**
078 103 385 K (8x)
M 11x1,5x133
2x



ZKHS **040.050**
078 198 025
2x





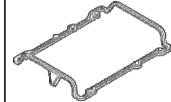





















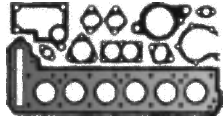
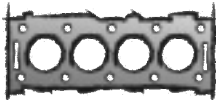

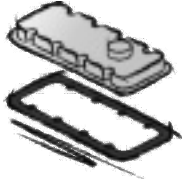
413.830
078 103 484 C
2x

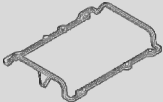















413.860
078 103 483 M
2x



			<p>a) </p> <p>b) </p>	<p>K: </p> <p>N: </p>	
<p>VAS 057.070 FPM 724.590 036 109 675 A FPM 30x</p>	<p>433.250 078 253 039 G 2x </p>	<p>433.301 078 129 717 N 2x </p>	<p>a) 030.793 Dirko HT</p> <p>b) 567.640 N 908 132 01 M 14x1,5x22</p>	<p>K:← 155.560 038 103 085 E ASW RD PTFE/ACM 35x48x10</p> <p>K:← 294.357 069 115 147 E ASW RD FPM/ACM 35x48x10</p> <p>K:← 475.961 054 115 147 B ASW RD FPM 35x48x10</p> <p>K:→ 728.880 078 103 051 G 070 103 051 A AW/BS LD PTFE/ACM 85x105x12</p> <p>N:← 129.780 038 103 085 C ASW RD PTFE/ACM 32x47x10 3x</p> <p>N:← 325.155 068 103 085 E ASW WD FPM/ACM 32x47x10 4x</p> <p>N:→ 326.470 028 103 086 A ASW LD PTFE/ACM 32x47x10 1x</p> <p>N:→ 798.040 028 103 086 C ASW OF LD FPM 32x47x10 1x</p>	
<p>VAS 057.070 FPM 724.590 036 109 675 A FPM 30x</p>	<p>433.250 078 253 039 G 2x </p>	<p>433.301 078 129 717 N 2x </p>	<p>a) 030.793 Dirko HT</p> <p>b) 567.640 N 908 132 01 M 14x1,5x22</p>	<p>K:← 155.560 038 103 085 E ASW RD PTFE/ACM 35x48x10</p> <p>K:← 294.357 069 115 147 E ASW RD FPM/ACM 35x48x10</p> <p>K:← 475.961 054 115 147 B ASW RD FPM 35x48x10</p> <p>K:→ 728.880 078 103 051 G 070 103 051 A AW/BS LD PTFE/ACM 85x105x12</p> <p>N:← 129.780 038 103 085 C ASW RD PTFE/ACM 32x47x10 3x</p> <p>N:← 325.155 068 103 085 E ASW WD FPM/ACM 32x47x10 4x</p> <p>N:→ 326.470 028 103 086 A ASW LD PTFE/ACM 32x47x10 1x</p> <p>N:→ 798.040 028 103 086 C ASW OF LD FPM 32x47x10 1x</p>	<p>TLS 305.890 </p>

<p>AUDI</p> 				
<p>ASJ AZR</p> <p>6 Cyl. 2671 ccm Cyl. 81,0 Ø</p> <p>A4 RS4 05/2000 → 09/2001</p>			<p>ZKS 130.850 078 103 385 K (8x) M 11x1,5x133 2x</p> 	<p>ZKHS 040.050 078 198 025 2x</p>  <p>413.830 078 103 484 C 2x</p>  <p>413.860 078 103 483 M 2x</p> 
<p>AZA</p> <p>6 Cyl. 2671 ccm Cyl. 81,0 Ø</p> <p>A6 12/1997 → 01/2005</p>	<p>ES 212.440 078 198 012 E 2x</p> <p>CS* 539.200 SZ 863.590 058 198 217 2x</p> 	<p>212.410 078 103 383 K 1,40 mm $\frac{+}{-}$ 83,5 Ø 2x</p> 	<p>ZKS 130.850 078 103 385 K (8x) M 11x1,5x133 2x</p> 	<p>ZKHS 040.050 078 198 025 2x</p>  <p>413.830 078 103 484 C 2x</p>  <p>413.860 078 103 483 M 2x</p> 

			<p>a) </p> <p>b) </p>	<p>K: </p> <p>N: </p>	
<p>VAS 057.070 FPM 724.590 036 109 675 A FPM 30x</p>	<p>433.250 078 253 039 G 2x </p>	<p>433.301 078 129 717 N 2x </p>	<p>a) 030.793 Dirko HT</p> <p>b) 567.640 N 908 132 01 M 14x1,5x22</p>	<p>K:← 155.560 038 103 085 E ASW RD PTFE/ACM 35x48x10</p> <p>N:← 325.155 068 103 085 E ASW WD FPM/ACM 32x47x10 4x</p>	
<p>VAS 057.070 FPM 724.590 036 109 675 A FPM 30x</p>	<p>433.250 078 253 039 G 2x </p>	<p>433.301 078 129 717 N 2x </p>	<p>a) 030.793 Dirko HT</p> <p>a) 467.762 078 103 610 E →4B-X-080 000 </p> <p>b) 567.640 N 908 132 01 M 14x1,5x22</p>	<p>K:← 155.560 038 103 085 E ASW RD PTFE/ACM 35x48x10</p> <p>K:← 294.357 069 115 147 E ASW RD FPM/ACM 35x48x10</p> <p>K:← 475.961 054 115 147 B ASW RD FPM 35x48x10</p> <p>K:→ 728.880 078 103 051 G 070 103 051 A AW/BS LD PTFE/ACM 85x105x12</p> <p>N:← 129.780 038 103 085 C ASW RD PTFE/ACM 32x47x10 3x</p> <p>N:← 325.155 068 103 085 E ASW WD FPM/ACM 32x47x10 4x</p> <p>N:→ 326.470 028 103 086 A ASW LD PTFE/ACM 32x47x10 1x</p> <p>N:→ 798.040 028 103 086 C ASW OF LD FPM 32x47x10 1x</p>	<p>TLS 305.890 </p>

AUDI

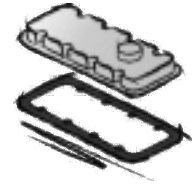
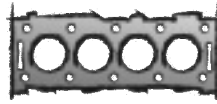

AGB
AZB
6 Cyl. **2671 ccm**
Cyl. 81,0 Ø

A4 S4
09/1997 → 09/2001

ES **212.440**
078 198 012 E
2x
CS* **539.200**
SZ **863.590**
058 198 217
2x



212.410
078 103 383 K
1,40 mm \pm 83,5 Ø
2x



ZKS **130.850**
078 103 385 K (8x)
M 11x1,5x133
2x



ZKHS **040.050**
078 198 025
2x



413.830
078 103 484 C
2x

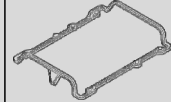

413.860
078 103 483 M
2x



BEL
6 Cyl. **2671 ccm**
Cyl. 81,0 Ø

A6
05/2001 → 07/2004
Allroad
09/2000 → 08/2005

ES **212.440**
078 198 012 E
2x
SZ **863.590**
058 198 217
2x



212.410
078 103 383 K
1,40 mm \pm 83,5 Ø
2x



ZKS **130.850**
078 103 385 K (8x)
M 11x1,5x133
2x



ZKHS **040.050**
078 198 025
2x





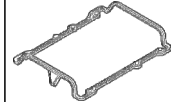











413.830
078 103 484 C
2x



413.860
078 103 483 M
2x



			<p>a) </p> <p>b) </p>	<p>K: </p> <p>N: </p>	
<p>VAS 057.070 FPM 724.590 036 109 675 A FPM 30x</p>	<p>433.250 078 253 039 G 2x </p>	<p>433.301 078 129 717 N 2x </p>	<p>a) 030.793 Dirko HT a) 467.762 078 103 610 E →8D-X-200 000 </p> <p>b) 567.640 N 908 132 01 M 14x1,5x22</p>	<p>K:← 155.560 038 103 085 E ASW RD PTFE/ACM 35x48x10 K:← 294.357 069 115 147 E ASW RD FPM/ACM 35x48x10 K:← 475.961 054 115 147 B ASW RD FPM 35x48x10 K:→ 728.880 078 103 051 G 070 103 051 A AW/BS LD PTFE/ACM 85x105x12 N:← 325.155 068 103 085 E ASW WD FPM/ACM 32x47x10 4x</p>	<p>TLS 305.890 </p>
<p>VAS 057.070 FPM 724.590 036 109 675 A FPM 30x</p>	<p>433.250 078 253 039 G 2x </p>	<p>433.301 078 129 717 N 2x </p>	<p>a) 030.793 Dirko HT b) 567.640 N 908 132 01 M 14x1,5x22</p>	<p>K:← 155.560 038 103 085 E ASW RD PTFE/ACM 35x48x10 K:← 294.357 069 115 147 E ASW RD FPM/ACM 35x48x10 K:← 475.961 054 115 147 B ASW RD FPM 35x48x10 K:→ 728.880 078 103 051 G 070 103 051 A AW/BS LD PTFE/ACM 85x105x12 N:← 129.780 038 103 085 C ASW RD PTFE/ACM 32x47x10 3x N:← 325.155 068 103 085 E ASW WD FPM/ACM 32x47x10 4x N:→ 326.470 028 103 086 A ASW LD PTFE/ACM 32x47x10 1x N:→ 798.040 028 103 086 C ASW OF LD FPM 32x47x10 1x</p>	

AUDI

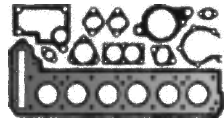

BPP
BSG

6 Cyl. **2698 ccm**
Cyl. 83,0 Ø

A4 TDI
11/2005 → 03/2009
A6 Allroad TDI
03/2006 → 08/2011
A6 TDI
11/2004 → 08/2011

ES⊕ **339.601**



CS* **397.230**

OKS **810.550**



018.050

059 103 383 CQ

0,390 mm



→ 0,490 mm

1,10 mm $\frac{+}{-}$ 84 Ø

L

1 ⊗

018.060

059 103 383 CR

0,490 mm



→ 0,540 mm

1,15 mm $\frac{+}{-}$ 84 Ø

L

2 ⊗

018.070

059 103 383 CS

0,540 mm



→ 0,650 mm

1,20 mm $\frac{+}{-}$ 84 Ø

L

3 ⊗

017.980

059 103 383 CM

0,390 mm



→ 0,490 mm

1,10 mm $\frac{+}{-}$ 84 Ø

R

1 ⊗

018.000

059 103 383 CN

0,490 mm



→ 0,540 mm

1,15 mm $\frac{+}{-}$ 84 Ø

R

2 ⊗

018.010

059 103 383 CP

0,540 mm



→ 0,650 mm

1,20 mm $\frac{+}{-}$ 84 Ø

R

3 ⊗

ZKS 130.110

057 103 384 A (8x)

M 12x1,5x159

2x



554.970

059 103 483 M

Cyl. 4-6

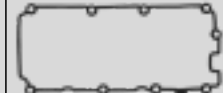











554.980

059 103 483 N

Cyl. 1-3



			<p>a) </p> <p>b) </p>	<p>K: </p> <p>N: </p>	
<p>VAS 235.650 FPM 724.590 036 109 675 A FPM 24x</p>	<p>148.271 059 253 039 E 2x </p>	<p>574.120 059 129 717 J 2x </p>	<p>a) 030.793 Dirko HT</p> <p>b) 982.340 N 016 027 6 incl. 813.036 M 14x1,5x12</p> <p>b) 591.840 N 013 815.8 Metal C 14x20x2</p> <p>b) 813.036 N 013 815.6 CU C 14x20x2</p>	<p>K:← 263.600 079 103 051 D ASW RD PTFE/ACM 55x70x8</p> <p>K:→ 026.790 079 103 051 F ASW LD PTFE/FPM 85x105x8,8</p> <p>N:← 325.155 068 103 085 E ASW WD FPM/ACM 32x47x10</p>	<p>TLS 247.120 </p>

AUDI

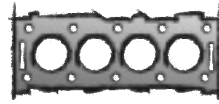
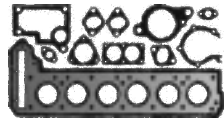

CAMA **CAMB**
CANA **CANB**
CANC **CAND**
CGKA **CGKB**

6 Cyl. **2698 ccm**
 Cyl. 83,0 Ø

A4 TDI
 11/2007 → 03/2012
A5 TDI
 06/2007 → 03/2012
A6 Allroad TDI
 05/2006 → 08/2011
A6 TDI
 11/2004 → 08/2011

ES⊕ **339.601**



CS* **397.230**

OKS **810.550**



735.470

059 103 383 ES

0,390 mm

→ 0,490 mm

1,10 mm $\frac{+}{-}$ 84 Ø

L

1 ⊗

735.490

059 103 383 ET

0,490 mm

→ 0,540 mm

1,15 mm $\frac{+}{-}$ 84 Ø

L

2 ⊗

735.500

059 103 383 FA

0,540 mm

→ 0,650 mm

1,20 mm $\frac{+}{-}$ 84 Ø

L

3 ⊗

735.400

059 103 383 EP

0,390 mm

→ 0,490 mm

1,10 mm $\frac{+}{-}$ 84 Ø

R

1 ⊗

735.430

059 103 383 EQ

0,490 mm

→ 0,540 mm

1,15 mm $\frac{+}{-}$ 84 Ø

R

2 ⊗

735.450

059 103 383 ER

0,540 mm

→ 0,650 mm

1,20 mm $\frac{+}{-}$ 84 Ø

R

3 ⊗

ZKS 130.110

057 103 384 A (8x)

M 12x1,5x159

2x



554.970

059 103 483 M

Cyl. 4-6













554.980

059 103 483 N

Cyl. 1-3



			<p>a) </p> <p>b) </p>	<p>K: </p> <p>N: </p>	
<p>VAS 235.650 FPM 724.590 036 109 675 A FPM 24x</p>	<p>148.271 059 253 039 E 2x </p>	<p>574.120 059 129 717 J 2x </p>	<p>a) 030.793 Dirko HT</p> <p>b) 982.340 N 016 027 6 incl. 813.036 M 14x1,5x12</p> <p>b) 591.840 N 013 815.8 Metal C 14x20x2</p> <p>b) 813.036 N 013 815.6 CU C 14x20x2</p>	<p>K:← 263.600 079 103 051 D ASW RD PTFE/ACM 55x70x8</p> <p>K:→ 026.790 079 103 051 F ASW LD PTFE/FPM 85x105x8,8</p> <p>N:← 325.155 068 103 085 E ASW WD FPM/ACM 32x47x10</p>	

AUDI

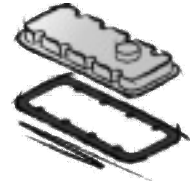
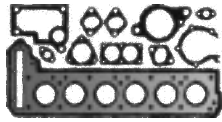

AAH
6 Cyl. **2771 ccm**
Cyl. 82,5 Ø

100
12/1990 → 07/1994

80
09/1991 → 01/1996

A4
01/1995 → 07/1997

A6
06/1994 → 12/1997

A8
03/1994 → 03/1996

Cabrio
11/1992 → 08/2000

Coupé
08/1991 → 12/1996

ES⊕ **215.970**
078 198 012
80 B4
→8C-S-025 820

Coupé B3
→8B-S-000 544

Cabrio B3
→8G-S-001 302

A6 4A2/4A5
→4A-S-026 714

ES⊕ **184.050**
078 198 012 A
Coupé B3
8B-T-002 001→

Cabrio B3
8G-T-004 319→

A4 8D2/8D5
8D-T-076 001→

A6 4A2/4A5
4A-T-029 513→

A8 4D2/4D8
4D-T-003 801→

CS* **670.740**
078 198 011 A
80 B4
8C-S-025 821→

Coupé B3
8B-S-000 545→

Cabrio B3
8G-S-001 303→
→8G-W-000 105

A4 8D2/8D5
→8D-V-205 000

A6 4A2/4A5
4A-S-026 715→

A8 4D2/4D8
4D-S-000 497→

CS* **539.200**
Cabrio B3
8G-W-000 106→

A4 8D2/8D5
8D-V-205 001→

CS* **632.740**
078 198 011
Coupé B3
→8B-S-000 544

Cabrio B3
→8G-S-001 302

80 B4
→8C-S-025 820

403.741
078 103 383 E
2x

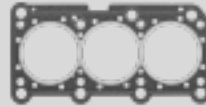

ZKS **804.250**
078 103 385 F (8x)
M 11x1,5x137
2x

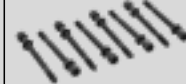

215.660
078 103 483 L
2x

Coupé B3
→8B-T-002 000

Cabrio B3
→8G-T-004 318

80 B4

A4 8D2/8D5
→8D-T-076 000

A6 4A2/4A5
→4A-T-029 512

A8 4D2/4D8
4D-T-003 800→



406.040
078 103 483 J
2x

Coupé B3
8B-T-002 001→









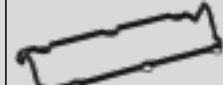

Cabrio B3
8G-T-004 319→

A4 8D2/8D5
8D-T-076 001→

A6 4A2/4A5
4A-T-029 513→

A8 4D2/4D8
4D-T-003 801→

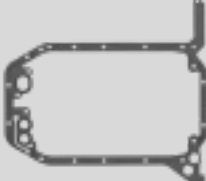

			<p>a) </p> <p>b) </p>	<p>K: </p> <p>N: </p>	
<p>VAS 825.050 FPM Coupé B3 8B-S-000 545→</p> <hr/> <p>Cabrio B3 8G-S-001 303→</p> <hr/> <p>80 B4 8CS-025 821→</p> <hr/> <p>A4 8D2/8D5</p> <hr/> <p>A6 4A2/4A5 4A-S-026 715→</p> <hr/> <p>A8 4D2/4D8</p> <p>553.190 026 109 675 FPM E A 12x</p> <hr/> <p>Coupé B3 →8B-S-000 544</p> <hr/> <p>Cabrio B3 →8G-S-001 302</p> <hr/> <p>80 B4 →8C-S-025 820</p> <hr/> <p>A6 4A2/4A5 →4A-S-026 714</p> <p>701.289 027 109 675 FPM E A 12x</p> <hr/> <p>Coupé B3 8B-S-000 545→</p> <hr/> <p>Cabrio B3 8G-S-001 303→</p> <hr/> <p>80 B4 8CS-025 821→</p> <hr/> <p>A4 8D2/8D5</p> <hr/> <p>A6 4A2/4A5 4A-S-026 715→</p> <hr/> <p>A8 4D2/4D8</p>	<p>632.690 078 129 589 2x</p> 	<p>632.700 078 129 717 A 2x</p> 	<p>a) 767.907 078 103 609 E ↑ Coupé B3 →8B-S-000 544</p> <hr/> <p>Cabrio B3 →8G-S-001 302</p> <hr/> <p>80 B4 →8C-S-025 820</p> <hr/> <p>A6 4A2/4A5 →4A-S-026 714</p> <hr/> <p>A8 4D2/4D8 →4D-S-000 496</p>  <p>a) 921.107 078 103 609 F ↑ Coupé B3 8B-S-000 545→</p> <hr/> <p>Cabrio B3 8G-S-001 303→ →8G-W-000 105</p> <hr/> <p>80 B4 8C-S-025 821→</p> <hr/> <p>A4 8D2/8D5 →8D-V-205 000</p> <hr/> <p>A6 4A2/4A5 4A-S-026 715→</p> <hr/> <p>A8 4D2/4D8 4D-S-000 497→</p>  <p>a) 030.793 Dirko HT ↑</p> <hr/> <p>Cabrio B3 8G-W-000 106→</p> <hr/> <p>A4 8D2/8D5 8D-V-205 001→</p> <p>a) 767.824 078 103 610 A 80 B4</p>	<p>K:← 294.357 069 115 147 E ASW RD FPM/ACM 35x48x10</p> <p>K:← 475.961 054 115 147 B ASW RD FPM 35x48x10</p> <p>K:→ 342.093 068 103 051 P ASW LD FPM 85x105x11</p> <p>K:→ 829.056 068 198 171 ASW LD FPM 85x105x11</p> <p>N:← 325.155 068 103 085 E ASW WD FPM/ACM 32x47x10 3x</p>	

AUDI

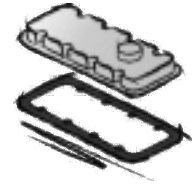

AAH

6 Cyl. **2771 ccm**
Cyl. 82,5 Ø

100

12/1990 → 07/1994

80

09/1991 → 01/1996

A4

01/1995 → 07/1997

A6

06/1994 → 12/1997

A8

03/1994 → 03/1996

Cabrio

11/1992 → 08/2000

Coupé

08/1991 → 12/1996

A6 4A2/4A5
→4A-S-026 714

A8 4D2/4D8
→4D-S-000 496

403.741

078 103 383 E
2x

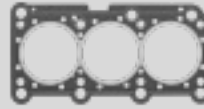

ZKS 804.250

078 103 385 F (8x)
M 11x1,5x137
2x

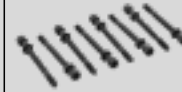

215.660

078 103 483 L
2x

Coupé B3
→8B-T-002 000

Cabrio B3
→8G-T-004 318

80 B4

A4 8D2/8D5
→8D-T-076 000

A6 4A2/4A5
→4A-T-029 512

A8 4D2/4D8
4D-T-003 800→



406.040

078 103 483 J
2x

Coupé B3
8B-T-002 001→









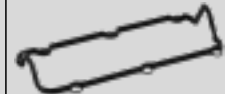



Cabrio B3
8G-T-004 319→

A4 8D2/8D5
8D-T-076 001→

A6 4A2/4A5
4A-T-029 513→

A8 4D2/4D8
4D-T-003 801→



			<p>a) </p> <p>b) </p>	<p>K: </p> <p>N: </p>	
<p>VAS 825.050 FPM Coupé B3 8B-S-000 545→</p> <hr/> <p>Cabrio B3 8G-S-001 303→</p> <hr/> <p>80 B4 8CS-025 821→</p> <hr/> <p>A4 8D2/8D5</p> <hr/> <p>A6 4A2/4A5 4A-S-026 715→</p> <hr/> <p>A8 4D2/4D8 553.190 026 109 675 FPM E A 12x</p> <hr/> <p>Coupé B3 →8B-S-000 544</p> <hr/> <p>Cabrio B3 →8G-S-001 302</p> <hr/> <p>80 B4 →8C-S-025 820</p> <hr/> <p>A6 4A2/4A5 →4A-S-026 714 701.289 027 109 675 FPM E A 12x</p> <hr/> <p>Coupé B3 8B-S-000 545→</p> <hr/> <p>Cabrio B3 8G-S-001 303→</p> <hr/> <p>80 B4 8CS-025 821→</p> <hr/> <p>A4 8D2/8D5</p> <hr/> <p>A6 4A2/4A5 4A-S-026 715→</p> <hr/> <p>A8 4D2/4D8</p>	<p>632.690 078 129 589 2x</p> 	<p>632.700 078 129 717 A 2x</p> 	<p>A8 4D2/4D8 Coupé B3 Cabrio B3 A6 4A2/4A5 →4D-S-000 496 →8B-S-000 544 →8G-S-001 302 →8C-S-025 820 →4A-S-026 714</p>  <p>a) 921.093 078 103 609 G 80 B4 A8 4D2/4D8 Cabrio B3 Coupé B3 A4 8D2/8D5 A6 4A2/4A5 4A-S-026 715→ 4D-S-000 497→ 8G-S-001 303→ 8B-S-000 545→ 8C-S-025 821→ →8G-W-000 105 →8D-V-205 000</p>  <p>a) 467.762 078 103 610 E Cabrio B3 A4 8D2/8D5 8G-W-000 106→ 8D-V-205 001→</p>  <p>b) 589.680 059 103 193 M 26x1,5x16 →07/1995</p> <p>b) 878.080 incl. 133.051 059 103 193 M 26x1,5x16 →07/1995</p> <p>b) 878.070 N 906 606 01 incl. 115.100 M 14x1,5x16 08/1995→</p> <p>b) 133.051 N 043 854.1 CU A 26x31x2 →07/1995</p> <p>b) 115.100 N 013 849.2 CU A 14x20x1,5</p>	<p>K:← 294.357 069 115 147 E ASW RD FPM/ACM 35x48x10</p> <p>K:← 475.961 054 115 147 B ASW RD FPM 35x48x10</p> <p>K:→ 342.093 068 103 051 P ASW LD FPM 85x105x11</p> <p>K:→ 829.056 068 198 171 ASW LD FPM 85x105x11</p> <p>N:← 325.155 068 103 085 E ASW WD FPM/ACM 32x47x10 3x</p>	

AUDI

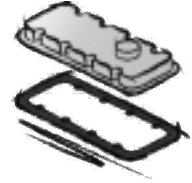
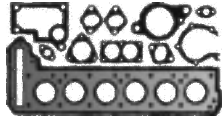

AAH

6 Cyl. **2771 ccm**
Cyl. 82,5 Ø

100

12/1990 → 07/1994

80

09/1991 → 01/1996

A4

01/1995 → 07/1997

A6

06/1994 → 12/1997

A8

03/1994 → 03/1996

Cabrio

11/1992 → 08/2000

Coupé

08/1991 → 12/1996

403.741

078 103 383 E
2x

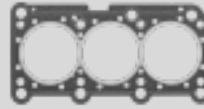

ZKS **804.250**

078 103 385 F (8x)
M 11x1,5x137
2x

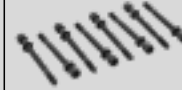

215.660

078 103 483 L
2x

Coupé B3
→8B-T-002 000

Cabrio B3
→8G-T-004 318

80 B4

A4 8D2/8D5
→8D-T-076 000

A6 4A2/4A5
→4A-T-029 512

A8 4D2/4D8
4D-T-003 800→



406.040

078 103 483 J
2x

Coupé B3
8B-T-002 001→

Cabrio B3
8G-T-004 319→







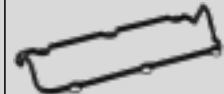



A4 8D2/8D5
8D-T-076 001→

A6 4A2/4A5
4A-T-029 513→

A8 4D2/4D8
4D-T-003 801→



AUDI

			<p>a) </p> <p>b) </p>	<p>K: </p> <p>N: </p>	
<p>VAS 825.050 FPM Coupé B3 8B-S-000 545→</p> <hr/> <p>Cabrio B3 8G-S-001 303→</p> <hr/> <p>80 B4 8CS-025 821→</p> <hr/> <p>A4 8D2/8D5</p> <hr/> <p>A6 4A2/4A5 4A-S-026 715→</p> <hr/> <p>A8 4D2/4D8</p> <p>553.190 026 109 675 FPM E A 12x</p> <hr/> <p>Coupé B3 →8B-S-000 544</p> <hr/> <p>Cabrio B3 →8G-S-001 302</p> <hr/> <p>80 B4 →8C-S-025 820</p> <hr/> <p>A6 4A2/4A5 →4A-S-026 714</p> <p>701.289 027 109 675 FPM E A 12x</p> <hr/> <p>Coupé B3 8B-S-000 545→</p> <hr/> <p>Cabrio B3 8G-S-001 303→</p> <hr/> <p>80 B4 8CS-025 821→</p> <hr/> <p>A4 8D2/8D5</p> <hr/> <p>A6 4A2/4A5 4A-S-026 715→</p> <hr/> <p>A8 4D2/4D8</p>	<p>632.690 078 129 589 2x</p> 	<p>632.700 078 129 717 A 2x</p> 	<p>08/1995→</p>	<p>K:← 294.357 069 115 147 E ASW RD FPM/ACM 35x48x10</p> <p>K:← 475.961 054 115 147 B ASW RD FPM 35x48x10</p> <p>K:→ 342.093 068 103 051 P ASW LD FPM 85x105x11</p> <p>K:→ 829.056 068 198 171 ASW LD FPM 85x105x11</p> <p>N:← 325.155 068 103 085 E ASW WD FPM/ACM 32x47x10 3x</p>	

AUDI

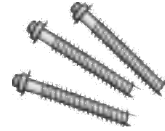
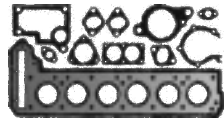

ACK

6 Cyl. **2771 ccm**
Cyl. 82,5 Ø

A4

10/1996 → 09/2001

A6

12/1995 → 01/2005

A8

04/1996 → 09/2002

ES

413.820
078 198 012 B
2x

A4 8D2/8D5
→8D-W-180 000

A6 4A2/4A5/4B2/4B5
→4B-W-150 000

A8 4D2/4D8
→4D-W-012 700

ES

470.650
2x

A4 8D2/8D5
8D-W-180 001→

A6 4A2/4A5/4B2/4B5
4B-W-150 001→

A8 4D2/4D8
4D-W-012 701→

CS*

670.740
078 198 011 A
A4 8D2/8D5
→8D-V-205 000

A6 4A2/4A5

A8 4D2/4D8
→4D-V-011 000

CS*

539.200
A4 8D2/8D5
8D-V-205 001→

A6 4B2/4B5

A8 4D2/4D8
4D-V-011 001→

SZ

863.590
058 198 217
2x



632.565

078 103 383 R
1,20 mm $\frac{+}{-}$ 83,5 Ø
2x



ZKS 130.850

078 103 385 K (8x)
M 11x1,5x133
2x



ZKHS 040.050
078 198 025
2x





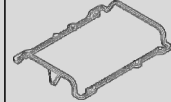









413.830
078 103 484 C
2x



413.860
078 103 483 M
2x

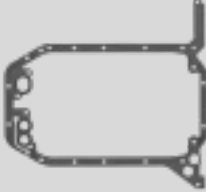

			<p>a) </p> <p>b) </p>	<p>K: </p> <p>N: </p>	
<p>VAS 057.070 FPM 724.590 036 109 675 A FPM 30x</p>	<p>632.760 078 253 039 C 2x</p> <p>A4 8D2/8D5 →8D-W-180 000</p> <p>A6 4A2/4A5/4B2/4B5 →4B-W-150 000</p> <p>A8 4D2/4D8 →4D-W-012 700</p>  <p>433.250 078 253 039 G 2x</p> <p>A4 8D2/8D5 8D-W-180 001→</p> <p>A6 4A2/4A5/4B2/4B5 4B-W-150 001→</p> <p>A8 4D2/4D8 4D-W-012 701→</p> 	<p>413.900 078 129 717 J 2x</p> 	<p>a) 921.107 078 103 609 F ↑ A4 8D2/8D5 →8D-V-205 000</p> <p>A6 4A2/4A5</p> <p>A8 4D2/4D8 →4D-V-011 000</p>  <p>a) 030.793 Dirko HT ↑</p> <p>A4 8D2/8D5 8D-V-205 001→</p> <p>A6 4B2/4B5</p> <p>A8 4D2/4D8 4D-V-011 000→</p> <p>a) 921.093 078 103 609 G A4 8D2/8D5 A6 4A2/4A5 A8 4D2/4D8 →8D-V-205 000 →4D-V-011 000</p>  <p>a) 467.762 078 103 610 E A8 4D2/4D8 A6 4B2/4B5 A4 8D2/8D5 4D-V-011 001→ 8D-V-205 001→ →4D-X-005 000 →4B-X-080 000 →8D-X-200 000</p>  <p>b) 878.070 N 906 606 01 incl. 115.100 M 14x1,5x16 →8D-V-205 000 →4D-V-011 000</p> <p>b) 567.640 N 908 132 01 M 14x1,5x22 4D-V-011 001→</p>	<p>K:← 294.357 069 115 147 E ASW RD FPM/ACM 35x48x10</p> <p>K:← 475.961 054 115 147 B ASW RD FPM 35x48x10</p> <p>K:→ 342.093 068 103 051 P ASW LD FPM 85x105x11</p> <p>K:→ 728.880 078 103 051 G 070 103 051 A AW/BS LD PTFE/ACM 85x105x12</p> <p>K:→ 829.056 068 198 171 ASW LD FPM 85x105x11</p> <p>N:← 325.155 068 103 085 E ASW WD FPM/ACM 32x47x10 4x</p>	

AUDI

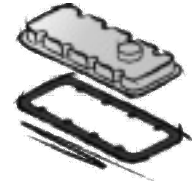
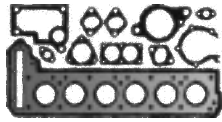

ACK
6 Cyl. **2771 ccm**
Cyl. 82,5 Ø

A4 10/1996 → 09/2001
A6 12/1995 → 01/2005
A8 04/1996 → 09/2002

ES **413.820**
078 198 012 B
2x
A4 8D2/8D5
→8D-W-180 000

A6 4A2/4A5/4B2/4B5
→4B-W-150 000

A8 4D2/4D8
→4D-W-012 700

ES **470.650**
2x

A4 8D2/8D5
8D-W-180 001→

A6 4A2/4A5/4B2/4B5
4B-W-150 001→

A8 4D2/4D8
4D-W-012 701→

CS* **670.740**
078 198 011 A
A4 8D2/8D5
→8D-V-205 000

A6 4A2/4A5

A8 4D2/4D8
→4D-V-011 000

CS* **539.200**
A4 8D2/8D5
8D-V-205 001→

A6 4B2/4B5

A8 4D2/4D8
4D-V-011 001→

SZ **863.590**
058 198 217
2x



632.565
078 103 383 R
1,20 mm $\frac{3}{4}$ 83,5 Ø
2x



ZKS **130.850**
078 103 385 K (8x)
M 11x1,5x133
2x



ZKHS **040.050**
078 198 025
2x













413.830
078 103 484 C
2x



413.860
078 103 483 M
2x



			<p>a) </p> <p>b) </p>	<p>K: </p> <p>N: </p>	
<p>VAS 057.070 FPM 724.590 036 109 675 A FPM 30x</p>	<p>632.760 078 253 039 C 2x</p> <hr/> <p>A4 8D2/8D5 →8D-W-180 000</p> <hr/> <p>A6 4A2/4A5/4B2/4B5 →4B-W-150 000</p> <hr/> <p>A8 4D2/4D8 →4D-W-012 700</p>  <p>433.250 078 253 039 G 2x</p> <hr/> <p>A4 8D2/8D5 8D-W-180 001→</p> <hr/> <p>A6 4A2/4A5/4B2/4B5 4B-W-150 001→</p> <hr/> <p>A8 4D2/4D8 4D-W-012 701→</p> 	<p>413.900 078 129 717 J 2x</p> 	<p>8D-V-205 001→</p> <p>b) 115.100 N 013 849.2 CU A 14x20x1,5 →4D-V-011 000 →8D-V-205 000</p>	<p>K:← 294.357 069 115 147 E ASW RD FPM/ACM 35x48x10</p> <p>K:← 475.961 054 115 147 B ASW RD FPM 35x48x10</p> <p>K:→ 342.093 068 103 051 P ASW LD FPM 85x105x11</p> <p>K:→ 728.880 078 103 051 G 070 103 051 A AW/BS LD PTFE/ACM 85x105x12</p> <p>K:→ 829.056 068 198 171 ASW LD FPM 85x105x11</p> <p>N:← 325.155 068 103 085 E ASW WD FPM/ACM 32x47x10 4x</p>	

AUDI

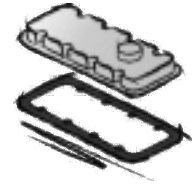

AEJ
6 Cyl. **2771 ccm**
Cyl. 82,5 Ø

A6
06/1994 → 07/1996

A8
07/1995 → 03/1996

ES⊕ **215.970**
078 198 012
A6 4A2/4A5
→4A-S-026 714

ES⊕ **184.050**
078 198 012 A
A6 4A2/4A5
4A-T-029 513→

A8 4D2/4D8
4D-T-003 801→

CS* **632.740**
078 198 011
A6 4A2/4A5
→4A-S-026 714

A8 4D2/4D8
→4D-S-000 496

CS* **670.740**
078 198 011 A
A6 4A2/4A5
4A-S-026 715→

A8 4D2/4D8
4D-S-000 497→

403.741
078 103 383 E
2x

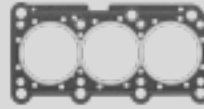

ZKS **804.250**
078 103 385 F (8x)
M 11x1,5x137
2x

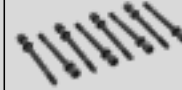

215.660
078 103 483 L
2x

A6 4A2/4A5
→4A-T-029 512

A8 4D2/4D8
→4D-T-003 800

















406.040
078 103 483 J
2x

A6 4A2/4A5
4A-T-029 513→

A8 4D2/4D8
4D-T-003 801→



AUDI

			<p>a) </p> <p>b) </p>	<p>K: </p> <p>N: </p>	
<p>VAS 825.050 FPM A6 4A2/4A5 4A-S-026 715→</p> <hr/> <p>A8 4D2/4D8</p> <p>553.190 026 109 675 FPM E A 12x</p> <hr/> <p>A6 4A2/4A5 →4A-S-026 714</p> <p>701.289 027 109 675 FPM E A 12x</p> <hr/> <p>A6 4A2/4A5 4A-S-026 715→</p> <hr/> <p>A8 4D2/4D8</p>	<p>632.690 078 129 589 2x</p> 	<p>632.700 078 129 717 A 2x</p> 	<p>a) 767.907 078 103 609 E ↑ A6 4A2/4A5 →4A-S-026 714</p> <hr/> <p>A8 4D2/4D8 →4D-S-000 496</p>  <p>a) 921.107 078 103 609 F ↑ A6 4A2/4A5 4A-S-026 715→</p> <hr/> <p>A8 4D2/4D8 4D-S-000 497→</p>  <p>a) 767.824 078 103 610 A A6 4A2/4A5 A8 4D2/4D8 →4A-S-026 714 →4D-S-000 496</p>  <p>a) 921.093 078 103 609 G A6 4A2/4A5 A8 4D2/4D8 4A-S-026 715→ 4D-S-000 497→</p>  <p>b) 878.070 N 906 606 01 incl. 115.100 M 14x1,5x16</p> <p>b) 115.100 N 013 849.2 CU A 14x20x1,5</p>	<p>K:← 294.357 069 115 147 E ASW RD FPM/ACM 35x48x10</p> <p>K:← 475.961 054 115 147 B ASW RD FPM 35x48x10</p> <p>K:→ 342.093 068 103 051 P ASW LD FPM 85x105x11</p> <p>K:→ 829.056 068 198 171 ASW LD FPM 85x105x11</p> <p>N:← 325.155 068 103 085 E ASW WD FPM/ACM 32x47x10 3x</p>	

AUDI



AFC
6 Cyl. **2771 ccm**
Cyl. 82,5 Ø

80
09/1991 → 12/1994

A4
01/1995 → 07/1997

A6
06/1994 → 12/1997

Cabrio
11/1992 → 08/2000

ES⊕ **184.050**
078 198 012 A
Cabrio B3
8G-T-004 319→

A4 8D2/8D5
8D-T-076 001→

A6 4A2/4A5
4A-T-029 513→

ES⊕ **215.970**
078 198 012
Cabrio B3
→8G-S-001 302

80 B4
→8C-S-025 820

A6 4A2/4A5
→4A-S-026 714

CS* **632.740**
078 198 011
Cabrio B3
→8G-S-001 302

80 B4
→8C-S-025 820

A6 4A2/4A5
→4A-S-026 714

CS* **670.740**
078 198 011 A
Cabrio B3
8G-S-001 303→
→8G-W-000 105

80 B4
8C-S-025 821→

A6 4A2/4A5
4A-S-026 715→

403.741
078 103 383 E
2x

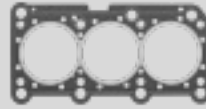

ZKS 804.250
078 103 385 F (8x)
M 11x1,5x137
2x

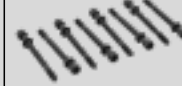

215.660
078 103 483 L
2x

Cabrio B3
→8G-T-004 318

80 B4

A4 8D2/8D5
→8D-T-076 000

A6 4A2/4A5
→4A-T-029 512



406.040
078 103 483 J
2x







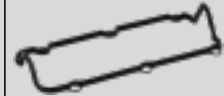





Cabrio B3
8G-T-004 319→







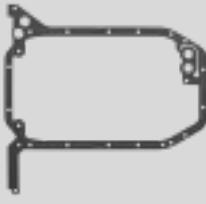



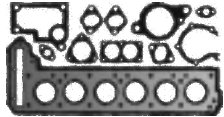
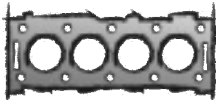

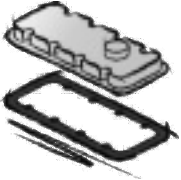
A4 8D2/8D5
8D-T-076 001→

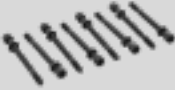













A6 4A2/4A5
4A-T-029 513→

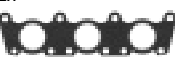

AUDI

			<p>a) </p> <p>b) </p>	<p>K: </p> <p>N: </p>	
<p>VAS 825.050 FPM Cabrio B3 8G-S-001 303→</p> <hr/> <p>80 B4 8C-S-025 821→</p> <hr/> <p>A6 4A2/4A5 4A-S-026 715→</p> <p>553.190 026 109 675 FPM 12x</p> <hr/> <p>Cabrio B3 →8G-S-001 302</p> <hr/> <p>80 B4 →8C-S-025 820</p> <hr/> <p>A6 4A2/4A5 →4A-S-026 714</p> <p>701.289 027 109 675 FPM 12x</p> <hr/> <p>Cabrio B3 8G-S-001 303→</p> <hr/> <p>80 B4 8C-S-025 821→</p> <hr/> <p>A6 4A2/4A5 4A-S-026 715→</p>	<p>632.690 078 129 589 2x</p> 	<p>632.700 078 129 717 A 2x</p> 	<p>a) 030.793 Dirko HT Cabrio B3 8G-W-000 106→</p> <hr/> <p>A4 8D2/8D5 8D-V 205 001→</p> <p>a) 767.907 078 103 609 E ↑ Cabrio B3 →8G-S-001 302</p> <hr/> <p>80 B4 →8C-S-025 820</p> <hr/> <p>A6 4A2/4A5 →4A-S-026 714</p>  <p>a) 921.107 078 103 609 F ↑ Cabrio B3 8G-S-001 303→ →8G-W-000 105</p> <hr/> <p>80 B4 8C-S-025 821→</p> <hr/> <p>A4 8D2/8D5 →8D-V 205 000</p> <hr/> <p>A6 4A2/4A5 4A-S-026 715→</p>  <p>a) 767.824 078 103 610 A 80 B4 Cabrio B3 A6 4A2/4A5 →8G-S-001 302 →8C-S-025 820 →4A-S-026 714</p>  <p>a) 921.093 078 103 609 G 80 B4 A6 4A2/4A5</p>	<p>K:← 294.357 069 115 147 E ASW RD FPM/ACM 35x48x10</p> <p>K:← 475.961 054 115 147 B ASW RD FPM 35x48x10</p> <p>K:→ 342.093 068 103 051 P ASW LD FPM 85x105x11</p> <p>K:→ 829.056 068 198 171 ASW LD FPM 85x105x11</p> <p>N:← 325.155 068 103 085 E ASW WD FPM/ACM 32x47x10 3x</p>	

<p>AUDI</p> 				
<p>AFC</p> <p>6 Cyl. 2771 ccm Cyl. 82,5 Ø</p> <p>80 09/1991 → 12/1994</p> <p>A4 01/1995 → 07/1997</p> <p>A6 06/1994 → 12/1997</p> <p>Cabrio 11/1992 → 08/2000</p>	<p>ES⊕ 184.050 078 198 012 A Cabrio B3 8G-T-004 319→</p> <hr/> <p>A4 8D2/8D5 8D-T-076 001→</p> <hr/> <p>A6 4A2/4A5 4A-T-029 513→</p> <p>ES⊕ 215.970 078 198 012 Cabrio B3 →8G-S-001 302</p> <hr/> <p>80 B4 →8C-S-025 820</p> <hr/> <p>A6 4A2/4A5 →4A-S-026 714</p> <p>CS* 632.740 078 198 011 Cabrio B3 →8G-S-001 302</p> <hr/> <p>80 B4 →8C-S-025 820</p> <hr/> <p>A6 4A2/4A5 →4A-S-026 714</p> <p>CS* 670.740 078 198 011 A Cabrio B3 8G-S-001 303→ →8G-W-000 105</p> <hr/> <p>80 B4 8C-S-025 821→</p> <hr/> <p>A6 4A2/4A5 4A-S-026 715→</p>	<p>403.741 078 103 383 E 2x</p> 	<p>ZKS 804.250 078 103 385 F (8x) M 11x1,5x137 2x</p> 	<p>215.660 078 103 483 L 2x</p> <hr/> <p>Cabrio B3 →8G-T-004 318</p> <hr/> <p>80 B4</p> <hr/> <p>A4 8D2/8D5 →8D-T-076 000</p> <hr/> <p>A6 4A2/4A5 →4A-T-029 512</p>  <p>406.040 078 103 483 J 2x</p> <hr/> <p>Cabrio B3 8G-T-004 319→</p> <hr/> <p>A4 8D2/8D5 8D-T-076 001→</p> <hr/> <p>A6 4A2/4A5 4A-T-029 513→</p> 
<p>AGE</p> <p>6 Cyl. 2771 ccm Cyl. 82,5 Ø</p> <p>A6 10/1997 → 05/2000</p>	<p>ES 413.820 078 198 012 B →4B-W-150 000 2x</p> <p>ES 470.650 4B-W-150 001→ 2x</p> <p>CS* 539.200</p> <p>SZ 863.590 058 198 217 2x</p> 	<p>632.565 078 103 383 R 1,20 mm $\frac{1}{2}$ 83,5 Ø 2x</p> 	<p>ZKS 130.850 078 103 385 K (8x) M 11x1,5x133 2x</p> 	<p>ZKHS 040.050 078 198 025 2x</p>  <p>413.830 078 103 484 C 2x</p>  <p>413.860 078 103 483 M 2x</p> 

			<p>a) </p> <p>b) </p>	<p>K: </p> <p>N: </p>	
<p>VAS 825.050 FPM Cabrio B3 8G-S-001 303→</p> <hr/> <p>80 B4 8C-S-025 821→</p> <hr/> <p>A6 4A2/4A5 4A-S-026 715→ 553.190 026 109 675 FPM 12x</p> <hr/> <p>Cabrio B3 →8G-S-001 302</p> <hr/> <p>80 B4 →8C-S-025 820</p> <hr/> <p>A6 4A2/4A5 →4A-S-026 714 701.289 027 109 675 FPM 12x</p> <hr/> <p>Cabrio B3 8G-S-001 303→</p> <hr/> <p>80 B4 8C-S-025 821→</p> <hr/> <p>A6 4A2/4A5 4A-S-026 715→</p>	<p>632.690 078 129 589 2x</p> 	<p>632.700 078 129 717 A 2x</p> 	<p>A4 8D2/8D5 Cabrio B3 8D-V 205 000→ 4A-S-026 715→ 8C-S-025 821→ 8G-S-001 303→ →8G-W-000 105</p>  <p>b) 589.680 059 103 193 M 26x1,5x16 →4A-T-020 000 →07/1995</p> <p>b) 878.080 incl. 133.051 059 103 193 M 26x1,5x16 →4A-T-020 000 →07/1995</p> <p>b) 878.070 N 906 606 01 incl. 115.100 M 14x1,5x16 4A-T-020 001→ 08/1995→</p> <p>b) 133.051 N 043 854.1 CU A 26x31x2 →07/1995</p> <p>b) 115.100 N 013 849.2 CU A 14x20x1,5 08/1995→</p>	<p>K:← 294.357 069 115 147 E ASW RD FPM/ACM 35x48x10</p> <p>K:← 475.961 054 115 147 B ASW RD FPM 35x48x10</p> <p>K:→ 342.093 068 103 051 P ASW LD FPM 85x105x11</p> <p>K:→ 829.056 068 198 171 ASW LD FPM 85x105x11</p> <p>N:← 325.155 068 103 085 E ASW WD FPM/ACM 32x47x10 3x</p>	
<p>VAS 057.070 FPM 724.590 036 109 675 A FPM 30x</p>	<p>632.760 078 253 039 C →4B-W-150 000 2x</p>  <p>433.250 078 253 039 G 4B-W-150 001→ 2x</p> 	<p>413.900 078 129 717 J 2x</p> 	<p>a) 030.793 Dirko HT</p> <p>a) 467.762 078 103 610 E →4B-X-080 000</p>  <p>b) 567.640 N 908 132 01 M 14x1,5x22</p>	<p>K:← 155.560 038 103 085 E ASW RD PTFE/ACM 35x48x10</p> <p>K:← 294.357 069 115 147 E ASW RD FPM/ACM 35x48x10</p> <p>K:← 475.961 054 115 147 B ASW RD FPM 35x48x10</p> <p>K:→ 728.880 078 103 051 G 070 103 051 A AW/BS LD PTFE/ACM 85x105x12</p> <p>N:← 325.155 068 103 085 E ASW WD FPM/ACM 32x47x10 4x</p>	

AUDI

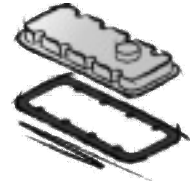
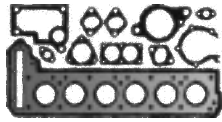

AHA
6 Cyl. **2771 ccm**
Cyl. 82,5 Ø

A4
10/1996 → 09/2001

A6
07/2008 → 10/2008

ES **413.820**
078 198 012 B
2x

A4 8D2/8D5
→8D-W-180 000

A6 4A2/4A5/4B2/4B5
→4B-W-150 000

ES **470.650**
2x

A4 8D2/8D5
8D-W-180 001→

A6 4A2/4A5/4B2/4B5
4B-W-150 001→

CS* **539.200**
SZ **863.590**
058 198 217
2x



632.565
078 103 383 R
1,20 mm $\frac{+}{-}$ 83,5 Ø
2x



ZKS **130.850**
078 103 385 K (8x)
M 11x1,5x133
2x



ZKHS **040.050**
078 198 025
2x



413.830
078 103 484 C
2x

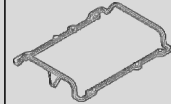

413.860
078 103 483 M
2x



AMX
6 Cyl. **2771 ccm**
Cyl. 82,5 Ø

A4
10/1996 → 09/2001

A6
02/1997 → 01/2005

A8
04/1996 → 09/2002

ES **413.820**
078 198 012 B
2x

A4 8D2/8D5
→8D-W-180 000

A6 4A2/4A5/4B2/4B5
→4B-W-150 000

A8 4D2/4D8
→4D-W-012 700
ES **470.650**
2x

A4 8D2/8D5
8D-W-180 001→

A6 4A2/4A5/4B2/4B5
4B-W-150 001→

A8 4D2/4D8
4D-W-012 701→
CS* **539.200**
SZ **863.590**
058 198 217
2x



632.565
078 103 383 R
1,20 mm $\frac{+}{-}$ 83,5 Ø
2x



ZKS **130.850**
078 103 385 K (8x)
M 11x1,5x133
2x



ZKHS **040.050**
078 198 025
2x





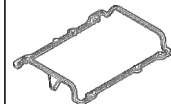













413.830
078 103 484 C
2x



413.860
078 103 483 M
2x



			<p>a) </p> <p>b) </p>	<p>K: </p> <p>N: </p>	
<p>VAS 057.070 FPM 724.590 036 109 675 A FPM 30x</p>	<p>632.760 078 253 039 C 2x</p> <hr/> <p>A4 8D2/8D5 →8D-W-180 000</p> <hr/> <p>A6 4A2/4A5/4B2/4B5 →4B-W-150 000</p>  <hr/> <p>433.250 078 253 039 G 2x</p> <hr/> <p>A4 8D2/8D5 8D-W-180 001→</p> <hr/> <p>A6 4A2/4A5/4B2/4B5 4B-W-150 001→</p> 	<p>413.900 078 129 717 J 2x</p> 	<p>a) 030.793 Dirko HT</p> <p>a) 467.762 078 103 610 E A6 4A2/4A5/4B2/4B5 A4 8D2/8D5 →4B-X-080 000 →8D-X-200 000</p>  <p>b) 567.640 N 908 132 01 M 14x1,5x22</p>	<p>K:← 155.560 038 103 085 E ASW RD PTFE/ACM 35x48x10</p> <p>K:← 294.357 069 115 147 E ASW RD FPM/ACM 35x48x10</p> <p>K:← 475.961 054 115 147 B ASW RD FPM 35x48x10</p> <p>K:→ 728.880 078 103 051 G 070 103 051 A AW/BS LD PTFE/ACM 85x105x12</p> <p>N:← 325.155 068 103 085 E ASW WD FPM/ACM 32x47x10 4x</p>	
<p>VAS 057.070 FPM 724.590 036 109 675 A FPM 30x</p>	<p>632.760 078 253 039 C 2x</p> <hr/> <p>A4 8D2/8D5 →8D-W-180 000</p> <hr/> <p>A6 4A2/4A5/4B2/4B5 →4B-W-150 000</p> <hr/> <p>A8 4D2/4D8 →4D-W-012 700</p>  <hr/> <p>433.250 078 253 039 G 2x</p> <hr/> <p>A4 8D2/8D5 8D-W-180 001→</p> <hr/> <p>A6 4A2/4A5/4B2/4B5 4B-W-150 001→</p> <hr/> <p>A8 4D2/4D8 4D-W-012 701→</p> 	<p>413.900 078 129 717 J 2x</p> 	<p>a) 030.793 Dirko HT</p> <p>a) 467.762 078 103 610 E A8 4D2/4D8 A6 4A2/4A5/4B2/4B5 A4 8D2/8D5 →4D-X-005 000 →4B-X-080 000 →8D-X-200 000</p>  <p>b) 567.640 N 908 132 01 M 14x1,5x22</p>	<p>K:← 155.560 038 103 085 E ASW RD PTFE/ACM 35x48x10</p> <p>K:← 294.357 069 115 147 E ASW RD FPM/ACM 35x48x10</p> <p>K:← 475.961 054 115 147 B ASW RD FPM 35x48x10</p> <p>K:→ 728.880 078 103 051 G 070 103 051 A AW/BS LD PTFE/ACM 85x105x12</p> <p>N:← 129.780 038 103 085 C ASW RD PTFE/ACM 32x47x10 3x</p> <p>N:← 325.155 068 103 085 E ASW WD FPM/ACM 32x47x10 4x</p> <p>N:→ 326.470 028 103 086 A ASW LD PTFE/ACM 32x47x10 1x</p> <p>N:→ 798.040 028 103 086 C ASW OF LD FPM 32x47x10 1x</p>	

AUDI

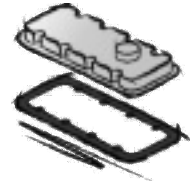

ALG AQR
APR
 6 Cyl. **2771 ccm**
 Cyl. 82,5 Ø

A4 10/1996 → 09/2001
A6 02/1997 → 01/2005
A8 04/1996 → 09/2002

ES **413.820**
 078 198 012 B
 2x
 A4 8D2/8D5
 →8D-W-180 000

A6 4A2/4A5/4B2/4B5
 →4B-W-150 000

A8 4D2/4D8
 →4D-W-012 700

ES **470.650**
 2x

A4 8D2/8D5
 8D-W-180 001→

A6 4A2/4A5/4B2/4B5
 4B-W-150 001→

A8 4D2/4D8
 4D-W-012 701→

CS* **539.200**
 SZ **863.590**

058 198 217
 2x



632.565
 078 103 383 R
 1,20 mm $\frac{1}{2}$ 83,5 Ø
 2x



ZKS **130.850**
 078 103 385 K (8x)
 M 11x1,5x133
 2x



ZKHS **040.050**
 078 198 025
 2x



413.830
 078 103 484 C
 2x

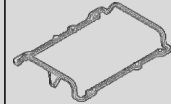

413.860
 078 103 483 M
 2x



ATQ
 6 Cyl. **2771 ccm**
 Cyl. 82,5 Ø

A4 10/1996 → 09/2001
A6 02/1997 → 01/2005

ES **470.650**
 2x
 CS* **539.200**
 SZ **863.590**
 058 198 217
 2x



632.565
 078 103 383 R
 1,20 mm $\frac{1}{2}$ 83,5 Ø
 2x



ZKS **130.850**
 078 103 385 K (8x)
 M 11x1,5x133
 2x



ZKHS **040.050**
 078 198 025
 2x

















413.830
 078 103 484 C
 2x



413.860
 078 103 483 M
 2x



			<p>a) </p> <p>b) </p>	<p>K: </p> <p>N: </p>	
<p>VAS 057.070 FPM 724.590 036 109 675 A FPM 30x</p>	<p>632.760 078 253 039 C 2x</p> <hr/> <p>A4 8D2/8D5 →8D-W-180 000</p> <hr/> <p>A6 4A2/4A5/4B2/4B5 →4B-W-150 000</p> <hr/> <p>A8 4D2/4D8 →4D-W-012 700</p>  <hr/> <p>433.250 078 253 039 G 2x</p> <hr/> <p>A4 8D2/8D5 8D-W-180 001→</p> <hr/> <p>A6 4A2/4A5/4B2/4B5 4B-W-150 001→</p> <hr/> <p>A8 4D2/4D8 4D-W-012 701→</p> 	<p>413.900 078 129 717 J 2x</p> 	<p>a) 030.793 Dirko HT</p> <p>a) 467.762 078 103 610 E A8 4D2/4D8 A6 4A2/4A5/4B2/4B5 A4 8D2/8D5 →4D-X-005 000 →4B-X-080 000 →8D-X-200 000</p>  <p>b) 567.640 N 908 132 01 M 14x1,5x22</p>	<p>K:← 155.560 038 103 085 E ASW RD PTFE/ACM 35x48x10</p> <p>K:← 294.357 069 115 147 E ASW RD FPM/ACM 35x48x10</p> <p>K:← 475.961 054 115 147 B ASW RD FPM 35x48x10</p> <p>K:→ 728.880 078 103 051 G 070 103 051 A AW/BS LD PTFE/ACM 85x105x12</p> <p>N:← 325.155 068 103 085 E ASW WD FPM/ACM 32x47x10 4x</p>	
<p>VAS 057.070 FPM 724.590 036 109 675 A FPM 30x</p>	<p>433.250 078 253 039 G 2x</p> 	<p>413.900 078 129 717 J 2x</p> 	<p>a) 030.793 Dirko HT</p> <p>b) 567.640 N 908 132 01 M 14x1,5x22</p>	<p>K:← 155.560 038 103 085 E ASW RD PTFE/ACM 35x48x10</p> <p>K:→ 342.093 068 103 051 P ASW LD FPM 85x105x11</p> <p>K:→ 728.880 078 103 051 G 070 103 051 A AW/BS LD PTFE/ACM 85x105x12</p> <p>K:→ 829.056 068 198 171 ASW LD FPM 85x105x11</p> <p>N:← 129.780 038 103 085 C ASW RD PTFE/ACM 32x47x10 3x</p> <p>N:← 325.155 068 103 085 E ASW WD FPM/ACM 32x47x10 4x</p> <p>N:→ 326.470 028 103 086 A ASW LD PTFE/ACM 32x47x10 1x</p> <p>N:→ 798.040 028 103 086 C ASW OF LD FPM 32x47x10 1x</p>	

AUDI

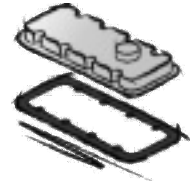

**ATX
BBG**

6 Cyl. **2771 ccm**
Cyl. 82,5 Ø

A4
03/1999 → 10/2000
A6
07/1999 → 01/2005

ES **470.650**
2x
CS* **539.200**
SZ **863.590**
058 198 217
2x



632.565
078 103 383 R
1,20 mm ± 83,5 Ø
2x



ZKS **130.850**
078 103 385 K (8x)
M 11x1,5x133
2x



ZKHS **040.050**
078 198 025
2x



413.830
078 103 484 C
2x

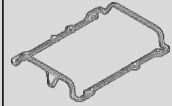

413.860
078 103 483 M
2x



BDX

6 Cyl. **2773 ccm**
Cyl. 84,5 Ø

A6
11/2006 → 10/2008
A8
08/2007 → 07/2010

ES⊕ **284.890**
CS* **244.710**

725.160
06E 103 149 M
86 Ø
Cyl. 4-6



725.190
06E 103 148 M
86 Ø
Cyl. 1-3



ZKS **325.040**
06E 103 385 E (8x)
M 10x1,5x172
2x



461.682
EL-Liq 74
↓

429.910
06E 103 483 Q
Cyl. 4-6



429.980
06E 103 484 P
Cyl. 1-3

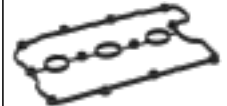

**CCDA CCEA
CJBA**

6 Cyl. **2773 ccm**
Cyl. 84,5 Ø

A6
10/2008 → 08/2011
A8
01/2009 → 07/2010

ES⊕ **284.890**

725.160
06E 103 149 M
86 Ø
Cyl. 4-6



725.190
06E 103 148 M
86 Ø
Cyl. 1-3



ZKS **325.040**
06E 103 385 E (8x)
M 10x1,5x172
2x







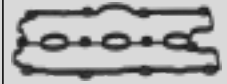



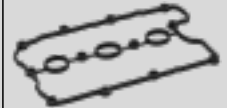





461.682
EL-Liq 74
↓











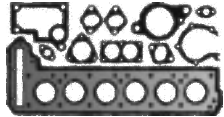
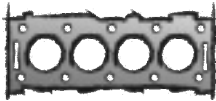

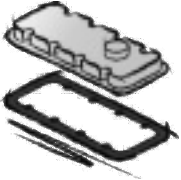

429.910
06E 103 483 Q
Cyl. 4-6



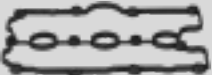
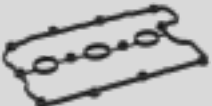



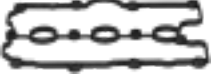
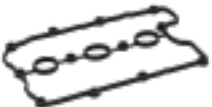

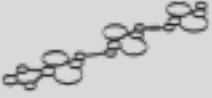
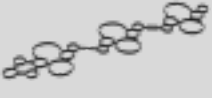





429.980
06E 103 484 P
Cyl. 1-3



			<p>a) </p> <p>b) </p>	<p>K: </p> <p>N: </p>	
<p>VAS 057.070 FPM 724.590 036 109 675 A FPM 30x</p>	<p>433.250 078 253 039 G 2x </p>	<p>413.900 078 129 717 J 2x </p>	<p>a) 030.793 Dirko HT b) 567.640 N 908 132 01 M 14x1,5x22</p>	<p>K:← 155.560 038 103 085 E ASW RD PTFE/ACM 35x48x10 K:→ 728.880 078 103 051 G 070 103 051 A AW/BS LD PTFE/ACM 85x105x12 N:← 129.780 038 103 085 C ASW RD PTFE/ACM 32x47x10 3x N:← 325.155 068 103 085 E ASW WD FPM/ACM 32x47x10 4x N:→ 326.470 028 103 086 A ASW LD PTFE/ACM 32x47x10 1x N:→ 798.040 028 103 086 C ASW OF LD FPM 32x47x10 1x</p>	
<p>VAS 235.650 FPM 724.590 036 109 675 A FPM 24x</p>	<p>724.250 06E 253 039 C 2x </p>	<p>232.910 06E 198 717 6x </p>	<p>a) 030.793 Dirko HT b) 982.340 N 016 027 6 incl. 813.036 M 14x1,5x12 b) 591.840 N 013 815.8 Metal C 14x20x2 b) 813.036 N 013 815.6 CU C 14x20x2</p>	<p>K:← 728.550 06E 103 153 E SP RD PTFE 45x60 K:→ 026.790 079 103 051 F ASW LD PTFE/FPM 85x105x8,8</p>	
<p>VAS 235.650 FPM 724.590 036 109 675 A FPM 24x</p>	<p>724.250 06E 253 039 C 2x </p>	<p>232.910 06E 198 717 6x </p>	<p>a) 030.793 Dirko HT b) 982.340 N 016 027 6 incl. 813.036 M 14x1,5x12 b) 591.840 N 013 815.8 Metal C 14x20x2 b) 813.036 N 013 815.6 CU C 14x20x2</p>	<p>K:← 728.550 06E 103 153 E SP RD PTFE 45x60 K:→ 026.790 079 103 051 F ASW LD PTFE/FPM 85x105x8,8</p>	

AUDI					
					
CHVA CNYA CNYB 6 Cyl. 2773 ccm Cyl. 84,5 Ø	ES⊕ 284.890 CS* 783.930	725.160 06E 103 149 M 86 Ø Cyl. 4-6 725.190 06E 103 148 M 86 Ø Cyl. 1-3	   	ZKS 325.040 06E 103 385 E (8x) M 10x1,5x172 →07/2011 2x ZKS 223.890 WHT 005 739 (8x) M 10x1,5x170 07/2011→ 2x 	461.682 EL-Liq 74 ↓ 429.910 06E 103 483 Q Cyl. 4-6  429.980 06E 103 484 P Cyl. 1-3 
A6 11/2010 → 04/2015 A7 10/2010 → 03/2015					
CVPA 6 Cyl. 2773 ccm Cyl. 84,5 Ø	CS* 783.930	796.160 06E 103 148 AR 0,85 mm $\frac{1}{4}$ 85,2 Ø Cyl. 1-3 796.170 06E 103 149 AR 0,85 mm $\frac{1}{4}$ 85,2 Ø Cyl. 4-6	 	ZKS 223.890 WHT 005 739 (8x) M 10x1,5x170 2x 	461.682 EL-Liq 74 ↓ 429.910 06E 103 483 Q Cyl. 4-6  429.980 06E 103 484 P Cyl. 1-3 
A6 09/2014 → 09/2018 A7 09/2014 → 05/2018					
DECA 6 Cyl. 2894 ccm Cyl. 84,5 Ø	CS* 519.440			ZKS 223.890 WHT 005 739 (8x) M 10x1,5x170 2x 	461.682 EL-Liq 74 938.250 06M 103 650 D Cyl. 1-3  938.240 06M 103 649 D Cyl. 4-6 
A4 RS4 10/2017 → 09/2019 A5 06/2018 → A5 RS5 04/2017 →					

AUDI

			<p>a) </p> <p>b) </p>	<p>K: </p> <p>N: </p>	
<p>VAS 235.650 FPM 724.590 036 109 675 A FPM 24x</p>	<p>724.250 06E 253 039 C 2x </p>	<p>232.910 06E 198 717 6x </p>	<p>a) 030.793 Dirko HT</p> <p>b) 982.340 N 016 027 6 incl. 813.036 M 14x1,5x12</p> <p>b) 591.840 N 013 815,8 Metal C 14x20x2</p> <p>b) 813.036 N 013 815,6 CU C 14x20x2</p>	<p>K:← 728.550 06E 103 153 E SP RD PTFE 45x60</p> <p>K:→ 026.790 079 103 051 F ASW LD PTFE/FPM 85x105x8,8</p>	
<p>VAS 235.650 FPM 724.590 036 109 675 A FPM 24x</p>	<p>724.250 06E 253 039 C 2x </p>	<p>232.910 06E 198 717 6x </p>	<p>a) 030.793 Dirko HT</p> <p>b) 591.840 N 013 815,8 Metal C 14x20x2</p> <p>b) 813.036 N 013 815,6 CU C 14x20x2</p>	<p>K:← 728.550 06E 103 153 E SP RD PTFE 45x60</p> <p>K:→ 026.790 079 103 051 F ASW LD PTFE/FPM 85x105x8,8</p>	
<p>VAS 562.250 FPM A 724.590 036 109 675 A FPM E 12x</p>		<p>928.300 06M 133 198 B 2x </p>	<p>a) 030.793 Dirko HT</p> <p>b) 858.050 N 911 679 01 incl. 591.840 M 14x1,5x15</p> <p>b) 243.205 N 013 849,3 AL A 14x20x1,5</p> <p>b) 591.840 N 013 815,8 Metal C 14x20x2</p>	<p>K:← 263.600 079 103 051 D ASW RD PTFE/ACM 55x70x8</p> <p>K:→ 026.790 079 103 051 F ASW LD PTFE/FPM 85x105x8,8</p>	

AUDI

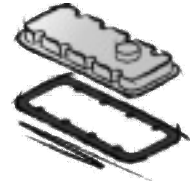
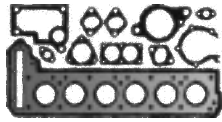

DKMB
6 Cyl. **2894 ccm**
Cyl. 84,5 Ø

A6
01/2020 →
A7 S7
01/2020 →

CS* **519.440**

ZKS 223.890
WHT 005 739 (8x)
M 10x1,5x170
2x



461.682
EL-Liq 74
938.250
06M 103 650 D
Cyl. 1-3

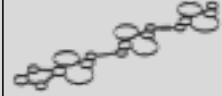

938.240
06M 103 649 D
Cyl. 4-6

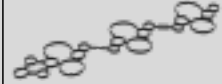

ASB
6 Cyl. **2967 ccm**
Cyl. 83,0 Ø

A4 TDI
01/2006 → 12/2015
A6 Allroad TDI
05/2006 → 10/2008
A6 TDI
06/2006 → 10/2008
A8 TDI
08/2003 → 07/2010

ES⊕ **339.601**



CS* **397.230**
OKS **810.550**



018.050

059 103 383 CQ

0,390 mm →
0,490 mm

1,10 mm ± 84 Ø
L
1 ⊗

018.060

059 103 383 CR

0,490 mm →
0,540 mm

1,15 mm ± 84 Ø
L
2 ⊗

018.070

059 103 383 CS

0,540 mm →
0,650 mm

1,20 mm ± 84 Ø
L
3 ⊗

017.980

059 103 383 CM

0,390 mm →
0,490 mm

1,10 mm ± 84 Ø
R
1 ⊗

018.000

059 103 383 CN

0,490 mm →
0,540 mm

1,15 mm ± 84 Ø
R
2 ⊗

018.010

059 103 383 CP

0,540 mm →
0,650 mm

1,20 mm ± 84 Ø
R
3 ⊗

ZKS 130.110
057 103 384 A (8x)
M 12x1,5x159
2x





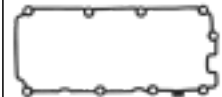









554.970
059 103 483 M
Cyl. 4-6



554.980
059 103 483 N
Cyl. 1-3



			<p>a) </p> <p>b) </p>	<p>K: </p> <p>N: </p>	
<p>VAS 562.250 FPM A 724.590 036 109 675 A FPM E 12x</p>		<p>928.300 06M 133 198 B 2x</p> 	<p>a) 030.793 Dirko HT</p> <p>b) 243.205 N 013 849.3 AL A 14x20x1,5</p>	<p>K:← 263.600 079 103 051 D ASW RD PTFE/ACM 55x70x8</p> <p>K:→ 026.790 079 103 051 F ASW LD PTFE/FPM 85x105x8,8</p>	
<p>VAS 235.650 FPM 724.590 036 109 675 A FPM 24x</p>	<p>148.271 059 253 039 E 2x</p> 	<p>574.120 059 129 717 J 2x</p> 	<p>a) 030.793 Dirko HT</p> <p>b) 982.340 N 016 027 6 incl. 813.036 M 14x1,5x12</p> <p>b) 878.100 incl. 813.168 028 103 059 A M 24x1,5x10 →4E-6-023 000 →4F-6-126 000</p> <p>b) 812.773 N 013 850.3 FE C 24x32x2,5 →4E-6-023 000 →4F-6-126 000</p> <p>b) 813.168 CU C 24x32x2,5 →4F-6-126 000 →4E-6-023 000</p> <p>b) 591.840 N 013 815.8 Metal C 14x20x2 4F-6-126 001→ 4E-6-023 001→</p> <p>b) 813.036 N 013 815.6 CU C 14x20x2 4F-6-126 001→ 4E-6-023 001→</p>	<p>K:← 263.600 079 103 051 D ASW RD PTFE/ACM 55x70x8</p> <p>K:→ 026.790 079 103 051 F ASW LD PTFE/FPM 85x105x8,8</p> <p>N:← 325.155 068 103 085 E ASW WD FPM/ACM 32x47x10</p>	<p>TLS 247.120</p> 

AUDI

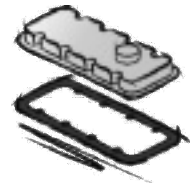
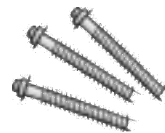
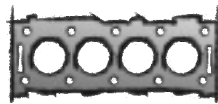
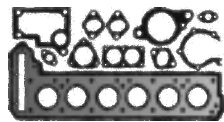

BMK

6 Cyl. **2967 ccm**
Cyl. 83,0 Ø

A6 TDI

05/2004 → 05/2006

ES⊕ **339.601**



CS* **397.230**

OKS **810.550**



018.050

059 103 383 CQ

→ 0,390 mm

→ 0,490 mm

1,10 mm $\frac{\pm}{\pm}$ 84 Ø

L

1 ⊗

1 ⊗

018.060

059 103 383 CR

→ 0,490 mm

→ 0,540 mm

1,15 mm $\frac{\pm}{\pm}$ 84 Ø

L

2 ⊗

2 ⊗

018.070

059 103 383 CS

→ 0,540 mm

→ 0,650 mm

1,20 mm $\frac{\pm}{\pm}$ 84 Ø

L

3 ⊗

3 ⊗

017.980

059 103 383 CM

→ 0,390 mm

→ 0,490 mm

1,10 mm $\frac{\pm}{\pm}$ 84 Ø

R

1 ⊗

1 ⊗

018.000

059 103 383 CN

→ 0,490 mm

→ 0,540 mm

1,15 mm $\frac{\pm}{\pm}$ 84 Ø

R

2 ⊗

2 ⊗

018.010

059 103 383 CP

→ 0,540 mm

→ 0,650 mm

1,20 mm $\frac{\pm}{\pm}$ 84 Ø

R

3 ⊗

3 ⊗

ZKS **130.110**

057 103 384 A (8x)

M 12x1,5x159

2x



554.970

059 103 483 M

Cyl. 4-6













554.980

059 103 483 N

Cyl. 1-3



			<p>a) </p> <p>b) </p>	<p>K: </p> <p>N: </p>	
<p>VAS 235.650 FPM 724.590 036 109 675 A FPM 24x</p>	<p>148.271 059 253 039 E 2x </p>	<p>574.120 059 129 717 J 2x </p>	<p>a) 030.793 Dirko HT</p> <p>b) 878.100 incl. 813.168 028 103 059 A M 24x1,5x10 →4F-6-126 000</p> <p>b) 982.340 N 016 027 6 incl. 813.036 M 14x1,5x12 4F-6-126 001→</p> <p>b) 812.773 N 013 850.3 FE C 24x32x2,5 →4F-6-126 000</p> <p>b) 813.168 CU C 24x32x2,5 →4F-6-126 000</p> <p>b) 591.840 N 013 815.8 Metal C 14x20x2 4F-6-126 001→</p> <p>b) 813.036 N 013 815.6 CU C 14x20x2 4F-6-126 001→</p>	<p>K:← 263.600 079 103 051 D ASW RD PTFE/ACM 55x70x8</p> <p>K:→ 026.790 079 103 051 F ASW LD PTFE/FPM 85x105x8,8</p> <p>N:← 325.155 068 103 085 E ASW WD FPM/ACM 32x47x10</p>	<p>TLS 247.120 </p>

AUDI



BNG

6 Cyl. **2967 ccm**
Cyl. 83,0 Ø

A6 Allroad TDI

05/2006 → 08/2011

A6 TDI

05/2004 → 08/2011

A8 TDI

11/2003 → 07/2010

ES⊕ **339.601**



CS* **397.230**

OKS **810.550**



018.050

059 103 383 CQ

0,390 mm

→ 0,490 mm

1,10 mm $\frac{+}{-}$ 84 Ø

L

1 ⊗

018.060

059 103 383 CR

0,490 mm

→ 0,540 mm

1,15 mm $\frac{+}{-}$ 84 Ø

L

2 ⊗

018.070

059 103 383 CS

0,540 mm

→ 0,650 mm

1,20 mm $\frac{+}{-}$ 84 Ø

L

3 ⊗

017.980

059 103 383 CM

0,390 mm

→ 0,490 mm

1,10 mm $\frac{+}{-}$ 84 Ø

R

1 ⊗

018.000

059 103 383 CN

0,490 mm

→ 0,540 mm

1,15 mm $\frac{+}{-}$ 84 Ø

R

2 ⊗

018.010

059 103 383 CP

0,540 mm

→ 0,650 mm

1,20 mm $\frac{+}{-}$ 84 Ø

R

3 ⊗

ZKS **130.110**

057 103 384 A (8x)

M 12x1,5x159

2x



554.970

059 103 483 M

Cyl. 4-6













554.980

059 103 483 N

Cyl. 1-3



			<p>a) </p> <p>b) </p>	<p>K: </p> <p>N: </p>	
<p>VAS 235.650 FPM 724.590 036 109 675 A FPM 24x</p>	<p>148.271 059 253 039 E 2x </p>	<p>574.120 059 129 717 J 2x </p>	<p>a) 030.793 Dirko HT</p> <p>b) 878.100 incl. 813.168 028 103 059 A M 24x1,5x10 →4E-6-023 000 →4F-6-126 000</p> <p>b) 982.340 N 016 027 6 incl. 813.036 M 14x1,5x12 4E-6-023 001→ 4F-6-126 001→</p> <p>b) 812.773 N 013 850.3 FE C 24x32x2,5 →4F-6-126 000 →4E-6-023 000</p> <p>b) 813.168 CU C 24x32x2,5 →4F-6-126 000 →4E-6-023 000</p> <p>b) 591.840 N 013 815.8 Metal C 14x20x2 4F-6-126 001→ 4E-6-023 001→</p> <p>b) 813.036 N 013 815.6 CU C 14x20x2 4F-6-126 001→ 4E-6-023 001→</p>	<p>K:← 263.600 079 103 051 D ASW RD PTFE/ACM 55x70x8</p> <p>K:→ 026.790 079 103 051 F ASW LD PTFE/FPM 85x105x8,8</p> <p>N:← 325.155 068 103 085 E ASW WD FPM/ACM 32x47x10</p>	<p>TLS 247.120 </p>

AUDI

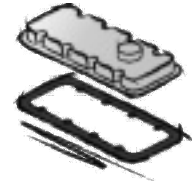
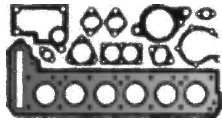

BKN **BUG**
BUN
 6 Cyl. 2967 ccm
 Cyl. 83,0 Ø

A4 TDI
 11/2004 → 03/2009
Q7 TDI
 03/2006 → 05/2010

ES⊕ **339.601**



CS* **397.230**

OKS **810.550**



018.050

059 103 383 CQ

→ 0,390 mm

→ 0,490 mm

1,10 mm $\frac{\pm}{\pm}$ 84 Ø

L

1 ⊗

018.060

059 103 383 CR

→ 0,490 mm

→ 0,540 mm

1,15 mm $\frac{\pm}{\pm}$ 84 Ø

L

2 ⊗

018.070

059 103 383 CS

→ 0,540 mm

→ 0,650 mm

1,20 mm $\frac{\pm}{\pm}$ 84 Ø

L

3 ⊗

017.980

059 103 383 CM

→ 0,390 mm

→ 0,490 mm

1,10 mm $\frac{\pm}{\pm}$ 84 Ø

R

1 ⊗

018.000

059 103 383 CN

→ 0,490 mm

→ 0,540 mm

1,15 mm $\frac{\pm}{\pm}$ 84 Ø

R

2 ⊗

018.010

059 103 383 CP

→ 0,540 mm

→ 0,650 mm

1,20 mm $\frac{\pm}{\pm}$ 84 Ø

R

3 ⊗

ZKS 130.110

057 103 384 A (8x)

M 12x1,5x159

2x



554.970

059 103 483 M

Cyl. 4-6













554.980

059 103 483 N

Cyl. 1-3



			<p>a) </p> <p>b) </p>	<p>K: </p> <p>N: </p>	
<p>VAS 235.650 FPM 724.590 036 109 675 A FPM 24x</p>	<p>148.271 059 253 039 E 2x </p>	<p>574.120 059 129 717 J 2x </p>	<p>a) 030.793 Dirko HT</p> <p>b) 982.340 N 016 027 6 incl. 813.036 M 14x1,5x12</p> <p>b) 591.840 N 013 815.8 Metal C 14x20x2</p> <p>b) 813.036 N 013 815.6 CU C 14x20x2</p>	<p>K:← 263.600 079 103 051 D ASW RD PTFE/ACM 55x70x8</p> <p>K:→ 026.790 079 103 051 F ASW LD PTFE/FPM 85x105x8,8</p> <p>N:← 325.155 068 103 085 E ASW WD FPM/ACM 32x47x10</p>	<p>TLS 247.120 </p>

AUDI

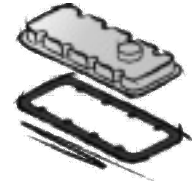
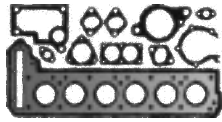

CAPA

6 Cyl. **2967 ccm**
Cyl. 83,0 Ø

A4 TDI

11/2007 → 03/2012

A5 TDI

06/2007 → 03/2012

ES⊕ **339.601**



CS* **397.230**

OKS **810.550**



018.050

059 103 383 CQ



0,390 mm

→ 0,490 mm



1,10 mm $\frac{+}{-}$ 84 Ø

L

1 ⊗

018.060

059 103 383 CR



0,490 mm

→ 0,540 mm



1,15 mm $\frac{+}{-}$ 84 Ø

L

2 ⊗

018.070

059 103 383 CS



0,540 mm

→ 0,650 mm



1,20 mm $\frac{+}{-}$ 84 Ø

L

3 ⊗

017.980

059 103 383 CM



0,390 mm

→ 0,490 mm



1,10 mm $\frac{+}{-}$ 84 Ø

R

1 ⊗

018.000

059 103 383 CN



0,490 mm

→ 0,540 mm



1,15 mm $\frac{+}{-}$ 84 Ø

R

2 ⊗

018.010

059 103 383 CP



0,540 mm

→ 0,650 mm



1,20 mm $\frac{+}{-}$ 84 Ø

R

3 ⊗

ZKS 130.110

057 103 384 A (8x)

M 12x1,5x159

2x



554.970

059 103 483 M

Cyl. 4-6













554.980

059 103 483 N

Cyl. 1-3



			<p>a) </p> <p>b) </p>	<p>K: </p> <p>N: </p>	
<p>VAS 235.650 FPM 724.590 036 109 675 A FPM 24x</p>	<p>148.271 059 253 039 E 2x </p>	<p>574.120 059 129 717 J 2x </p>	<p>a) 030.793 Dirko HT</p> <p>b) 982.340 N 016 027 6 incl. 813.036 M 14x1,5x12</p> <p>b) 591.840 N 013 815.8 Metal C 14x20x2</p> <p>b) 813.036 N 013 815.6 CU C 14x20x2</p>	<p>K:← 263.600 079 103 051 D ASW RD PTFE/ACM 55x70x8</p> <p>K:→ 026.790 079 103 051 F ASW LD PTFE/FPM 85x105x8,8</p> <p>N:← 325.155 068 103 085 E ASW WD FPM/ACM 32x47x10</p>	

AUDI

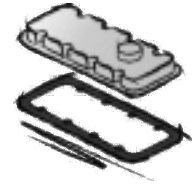
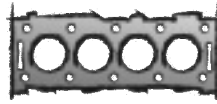
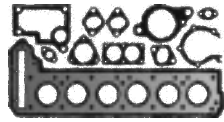

CASA CASB
CATA CCLA
CCMA CCWA
CCWB CDYA
CDYB CDYC

6 Cyl. 2967 ccm
Cyl. 83,0 Ø

- A4 Allroad TDI**
04/2009 → 01/2012
- A4 TDI**
11/2007 → 03/2012
- A5 TDI**
06/2007 → 03/2012
- A6 Allroad TDI**
05/2006 → 08/2011
- A6 TDI**
05/2004 → 08/2011
- Q5 TDI**
11/2008 → 05/2017
- Q7 TDI**
03/2006 → 08/2015

ES⊕ **339.601**



CS* **397.230**

OKS **810.550**



735.470

059 103 383 ES

0,390 mm

→ 0,490 mm

1,10 mm $\frac{+}{-}$ 84 Ø

L

1 ⊗

735.490

059 103 383 ET

0,490 mm

→ 0,540 mm

1,15 mm $\frac{+}{-}$ 84 Ø

L

2 ⊗

735.500

059 103 383 FA

0,540 mm

→ 0,650 mm

1,20 mm $\frac{+}{-}$ 84 Ø

L

3 ⊗

735.400

059 103 383 EP

0,390 mm

→ 0,490 mm

1,10 mm $\frac{+}{-}$ 84 Ø

R

1 ⊗

735.430

059 103 383 EQ

0,490 mm

→ 0,540 mm

1,15 mm $\frac{+}{-}$ 84 Ø

R

2 ⊗

735.450

059 103 383 ER

0,540 mm

→ 0,650 mm

1,20 mm $\frac{+}{-}$ 84 Ø

R

3 ⊗

ZKS **130.110**

057 103 384 A (8x)

M 12x1,5x159

2x



554.970

059 103 483 M

Cyl. 4-6

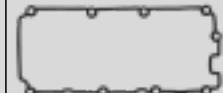







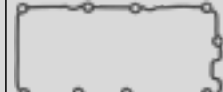



554.980

059 103 483 N

Cyl. 1-3



			<p>a) </p> <p>b) </p>	<p>K: </p> <p>N: </p>	
<p>VAS 235.650 FPM 724.590 036 109 675 A FPM 24x</p>	<p>148.271 059 253 039 E 2x </p>	<p>574.120 059 129 717 J 2x </p>	<p>a) 030.793 Dirko HT</p> <p>b) 982.340 N 016 027 6 incl. 813.036 M 14x1,5x12</p> <p>b) 591.840 N 013 815.8 Metal C 14x20x2</p> <p>b) 813.036 N 013 815.6 CU C 14x20x2</p>	<p>K:← 263.600 079 103 051 D ASW RD PTFE/ACM 55x70x8</p> <p>K:→ 026.790 079 103 051 F ASW LD PTFE/FPM 85x105x8,8</p> <p>N:← 325.155 068 103 085 E ASW WD FPM/ACM 32x47x10</p>	

AUDI



CDUC CKVC

6 Cyl. **2967 ccm**
Cyl. 83,0 Ø

- A4 Allroad TDI**
01/2012 → 05/2016
- A4 TDI**
11/2011 → 12/2015
- A5 TDI**
10/2011 → 01/2017
- A6 Allroad TDI**
01/2012 → 06/2016
- A6 TDI**
03/2011 → 09/2018
- A7 TDI**
10/2010 → 06/2016

ES⊕ **323.520**



CS* **339.380**
A7 4GA/4GF
A6 4G2/4G5
→02/2013

A4 8K2/8K5
A5 8T3/8F7
→04/2013

CS* **341.000**
A6 4G2/4G5
A7 4GA/4GF
02/2013→

A5 8T3/8F7
A4 8K2/8K5
04/2013→

OKS **908.400**
OKS **526.820**

299.800

059 103 383 KP
0,820 mm
→
0,920 mm
1,58 mm $\frac{+}{-}$ 84 Ø
L
1 ⊗



299.810

059 103 383 KQ
0,920 mm
→
0,970 mm
1,63 mm $\frac{+}{-}$ 84 Ø
L
2 ⊗



299.820

059 103 383 KR
0,970 mm
→
1,080 mm
1,68 mm $\frac{+}{-}$ 84 Ø
L
3 ⊗



299.720

059 103 383 KL
0,820 mm
→
0,920 mm
1,58 mm $\frac{+}{-}$ 84 Ø
R
1 ⊗



299.780

059 103 383 KM
0,920 mm
→
0,970 mm
1,63 mm $\frac{+}{-}$ 84 Ø
R
2 ⊗

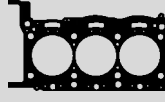

299.790

059 103 383 KN
0,970 mm
→
1,080 mm
1,68 mm $\frac{+}{-}$ 84 Ø
R
3 ⊗

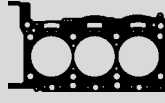

ZKS **586.360**

WHT 005 262 A (8x)
M 12x1,5x175
2x

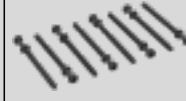

311.140

059 103 483 T
Cyl. 4-6

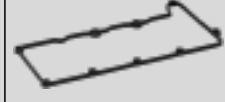

311.160



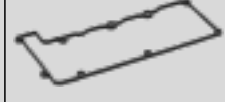







059 103 484
Cyl. 1-3



323.480

059 103 085 L
6x

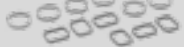

			<p>a) </p> <p>b) </p>	<p>K: </p> <p>N: </p>	
<p>VAS 235.650 FPM 724.590 036 109 675 A FPM 24x</p>	<p>048.800 059 253 039 N 2x </p>	<p>AAS 427.130 </p>	<p>a) 030.793 Dirko HT</p> <p>b) 858.050 N 911 679 01 incl. 591.840 M 14x1,5x15</p> <p>b) 982.340 N 016 027 6 incl. 813.036 M 14x1,5x12</p> <p>b) 591.840 N 013 815.8 Metal C 14x20x2</p> <p>b) 813.036 N 013 815.6 CU C 14x20x2</p>	<p>K:← 263.600 079 103 051 D ASW RD PTFE/ACM 55x70x8</p> <p>K:→ 331.330 059 103 051 K ASW OF LD FPM 85x105x8</p>	<p>TLS 311.330 </p>

AUDI

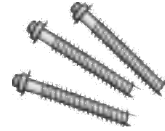
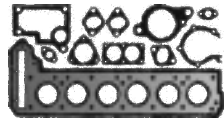

CDUD

6 Cyl. **2967 ccm**
Cyl. 83,0 Ø

A6 Allroad TDI

01/2012 → 06/2016

A6 TDI

03/2011 → 09/2018

A7 TDI

10/2010 → 06/2016

Q5 TDI

06/2012 → 05/2017

ES⊕ **323.520**



CS*

339.380

A6 4G2/4G5
A7 4GA/4GF
→02/2013

Q5

→04/2013

CS*

341.000

A6 4G2/4G5
A7 4GA/4GF
02/2013→

Q5

04/2013→

OKS

908.400

OKS

526.820

299.800

059 103 383 KP

0,820 mm



→ 0,920 mm

1,58 mm $\frac{+}{-}$ 84 Ø

L

1 ⊗



299.810

059 103 383 KQ

0,920 mm



→ 0,970 mm

1,63 mm $\frac{+}{-}$ 84 Ø

L

2 ⊗



299.820

059 103 383 KR

0,970 mm



→ 1,080 mm

1,68 mm $\frac{+}{-}$ 84 Ø

L

3 ⊗



299.720

059 103 383 KL

0,820 mm



→ 0,920 mm

1,58 mm $\frac{+}{-}$ 84 Ø

R

1 ⊗

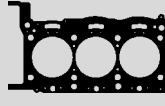

299.780

059 103 383 KM

0,920 mm



→ 0,970 mm

1,63 mm $\frac{+}{-}$ 84 Ø

R

2 ⊗

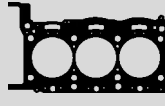

299.790

059 103 383 KN

0,970 mm



→ 1,080 mm

1,68 mm $\frac{+}{-}$ 84 Ø

R

3 ⊗

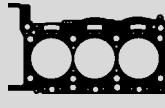

ZKS **586.360**

WHT 005 262 A (8x)

M 12x1,5x175

2x



311.140

059 103 483 T

Cyl. 4-6

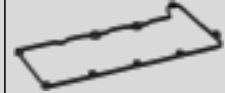

311.160

059 103 484

Cyl. 1-3

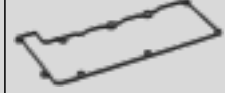











323.480

059 103 085 L

6x

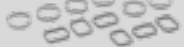

			<p>a) </p> <p>b) </p>	<p>K: </p> <p>N: </p>	
<p>VAS 235.650 FPM 724.590 036 109 675 A FPM 24x</p>	<p>048.800 059 253 039 N 2x </p>	<p>AAS 427.130 </p>	<p>a) 030.793 Dirko HT</p> <p>b) 858.050 N 911 679 01 incl. 591.840 M 14x1,5x15</p> <p>b) 982.340 N 016 027 6 incl. 813.036 M 14x1,5x12</p> <p>b) 591.840 N 013 815.8 Metal C 14x20x2</p> <p>b) 813.036 N 013 815.6 CU C 14x20x2</p>	<p>K:← 263.600 079 103 051 D ASW RD PTFE/ACM 55x70x8</p> <p>K:→ 331.330 059 103 051 K ASW OF LD FPM 85x105x8</p>	<p>TLS 311.330 </p>

AUDI

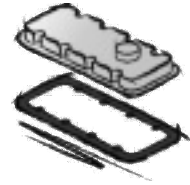
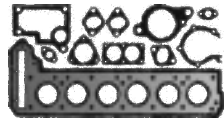

CGQB
6 Cyl. **2967 ccm**
Cyl. 83,0 Ø

A6 Allroad TDI
01/2012 → 12/2014
A6 TDI
11/2011 → 09/2018
A7 TDI
11/2011 → 03/2015
Q5 TDI
12/2012 → 11/2015

CS* **339.380**
→02/2013
CS* **341.000**
02/2013→

524.390
059 103 383 NK
1,58 mm \pm 84 Ø
L
1 ⊗



524.400
059 103 383 NL
1,63 mm \pm 84 Ø
L
2 ⊗



524.410
059 103 383 NM
1,68 mm \pm 84 Ø
L
3 ⊗



524.340
059 103 383 NG
1,58 mm \pm 84 Ø
R
1 ⊗



524.350
059 103 383 NH
1,63 mm \pm 84 Ø
R
2 ⊗

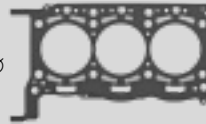

524.360
059 103 383 NJ
1,68 mm \pm 84 Ø
R
3 ⊗



ZKS **586.360**
WHT 005 262 A (8x)
M 12x1,5x175
2x



311.140
059 103 483 T
Cyl. 4-6

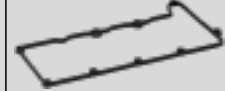









311.160
059 103 484
Cyl. 1-3



323.480
059 103 085 L
6x

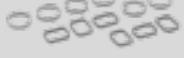

AUDI

			<p>a) </p> <p>b) </p>	<p>K: </p> <p>N: </p>	
<p>VAS 235.650 FPM 724.590 036 109 675 A FPM 24x</p>	<p>121.610 059 253 039 Q 2x</p> 	<p>AAS 427.130</p> 	<p>a) 030.793 Dirko HT</p> <p>b) 858.050 N 911 679 01 incl. 591.840 M 14x1,5x15</p> <p>b) 982.340 N 016 027 6 incl. 813.036 M 14x1,5x12</p> <p>b) 591.840 N 013 815.8 Metal C 14x20x2</p> <p>b) 813.036 N 013 815.6 CU C 14x20x2</p>	<p>K:← 263.600 079 103 051 D ASW RD PTFE/ACM 55x70x8</p> <p>K:→ 331.330 059 103 051 K ASW OF LD FPM 85x105x8</p>	

AUDI

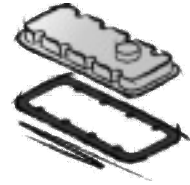

CJGA CJGC
CJGD CJMA
CLZB CNRB
CRCA

6 Cyl. **2967 ccm**
 Cyl. 83,0 Ø

Q7 TDI
 11/2007 → 08/2015

ES⊕ **323.520**



CS* **339.380**
 →05/2013

CS* **341.000**
 05/2013→

OKS **908.400**

OKS **526.820**

299.800

059 103 383 KP

0,820 mm

→ 0,920 mm

1,58 mm $\frac{+}{-}$ 84 Ø

L

1 ⊗

299.810

059 103 383 KQ

0,920 mm

→ 0,970 mm

1,63 mm $\frac{+}{-}$ 84 Ø

L

2 ⊗

299.820

059 103 383 KR

0,970 mm

→ 1,080 mm

1,68 mm $\frac{+}{-}$ 84 Ø

L

3 ⊗

299.720

059 103 383 KL

0,820 mm

→ 0,920 mm

1,58 mm $\frac{+}{-}$ 84 Ø

R

1 ⊗

299.780

059 103 383 KM

0,920 mm

→ 0,970 mm

1,63 mm $\frac{+}{-}$ 84 Ø

R

2 ⊗

299.790

059 103 383 KN

0,970 mm

→ 1,080 mm

1,68 mm $\frac{+}{-}$ 84 Ø

R

3 ⊗

ZKS **586.360**

WHT 005 262 A (8x)

M 12x1,5x175

2x

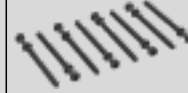

311.140

059 103 483 T

Cyl. 4-6

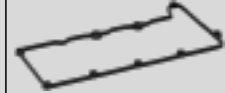

311.160

059 103 484

Cyl. 1-3

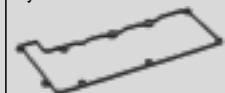











323.480

059 103 085 L

6x



			<p>a) </p> <p>b) </p>	<p>K: </p> <p>N: </p>	
<p>VAS 235.650 FPM 724.590 036 109 675 A FPM 24x</p>	<p>048.800 059 253 039 N 2x </p>	<p>AAS 427.130 </p>	<p>a) 030.793 Dirko HT</p> <p>b) 982.340 N 016 027 6 incl. 813.036 M 14x1,5x12</p> <p>b) 591.840 N 013 815.8 Metal C 14x20x2</p> <p>b) 813.036 N 013 815.6 CU C 14x20x2</p>	<p>K:← 263.600 079 103 051 D ASW RD PTFE/ACM 55x70x8</p> <p>K:→ 331.330 059 103 051 K ASW OF LD FPM 85x105x8</p>	<p>TLS 311.330 </p>

AUDI



CKVD
6 Cyl. **2967 ccm**
Cyl. 83,0 Ø

A5 TDI
05/2015 → 01/2017

ES⊕ **323.520**



CS* **341.000**
OKS **908.400**
OKS **526.820**

299.800

059 103 383 KP
 0,820 mm
 → 0,920 mm
 1,58 mm $\frac{\pm}{\pm}$ 84 Ø
 L
 1 ⊗



299.810

059 103 383 KQ
 0,920 mm
 → 0,970 mm
 1,63 mm $\frac{\pm}{\pm}$ 84 Ø
 L
 2 ⊗



299.820

059 103 383 KR
 0,970 mm
 → 1,080 mm
 1,68 mm $\frac{\pm}{\pm}$ 84 Ø
 L
 3 ⊗



299.720

059 103 383 KL
 0,820 mm
 → 0,920 mm
 1,58 mm $\frac{\pm}{\pm}$ 84 Ø
 R
 1 ⊗

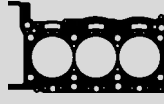

299.780

059 103 383 KM
 0,920 mm
 → 0,970 mm
 1,63 mm $\frac{\pm}{\pm}$ 84 Ø
 R
 2 ⊗



299.790

059 103 383 KN
 0,970 mm
 → 1,080 mm
 1,68 mm $\frac{\pm}{\pm}$ 84 Ø
 R
 3 ⊗

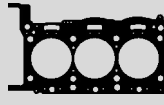

ZKS **586.360**

WHT 005 262 A (8x)
M 12x1,5x175
2x



311.140

059 103 483 T
Cyl. 4-6

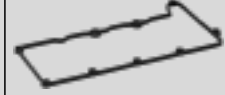

311.160











059 103 484
Cyl. 1-3



323.480

059 103 085 L
6x

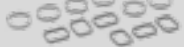

			<p>a) </p> <p>b) </p>	<p>K: </p> <p>N: </p>	
<p>VAS 235.650 FPM 724.590 036 109 675 A FPM 24x</p>	<p>048.800 059 253 039 N 2x </p>	<p>AAS 427.130 </p>	<p>a) 030.793 Dirko HT</p> <p>b) 858.050 N 911 679 01 incl. 591.840 M 14x1,5x15</p> <p>b) 982.340 N 016 027 6 incl. 813.036 M 14x1,5x12</p> <p>b) 591.840 N 013 815.8 Metal C 14x20x2</p> <p>b) 813.036 N 013 815.6 CU C 14x20x2</p>	<p>K:← 263.600 079 103 051 D ASW RD PTFE/ACM 55x70x8</p> <p>K:→ 331.330 059 103 051 K ASW OF LD FPM 85x105x8</p>	<p>TLS 311.330 </p>

AUDI

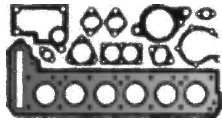

CLAA

6 Cyl. **2967 ccm**
Cyl. 83,0 Ø

A6 Allroad TDI

01/2012 → 12/2014

A6 TDI

03/2011 → 09/2018

A7 TDI

12/2010 → 03/2015

ES⊕ **323.520**



CS* **339.380**

→02/2013

CS* **341.000**

02/2013→

OKS **908.400**

OKS **526.820**

299.800

059 103 383 KP

0,820 mm

→ 0,920 mm

1,58 mm $\frac{+}{-}$ 84 Ø

L

1 ⊗

1 ⊗

1 ⊗

1 ⊗

1 ⊗

1 ⊗

1 ⊗

1 ⊗

1 ⊗

1 ⊗

1 ⊗

1 ⊗

1 ⊗

1 ⊗

1 ⊗

1 ⊗

1 ⊗

1 ⊗

1 ⊗

1 ⊗

1 ⊗

1 ⊗

1 ⊗

1 ⊗

1 ⊗

1 ⊗

1 ⊗

1 ⊗

1 ⊗

1 ⊗

1 ⊗

1 ⊗

1 ⊗

1 ⊗

1 ⊗

1 ⊗

1 ⊗

1 ⊗

1 ⊗

1 ⊗

1 ⊗

1 ⊗

1 ⊗

1 ⊗

1 ⊗

1 ⊗

1 ⊗

1 ⊗

1 ⊗

1 ⊗

1 ⊗

1 ⊗

1 ⊗

1 ⊗

1 ⊗

1 ⊗

1 ⊗

1 ⊗

1 ⊗

1 ⊗

1 ⊗

1 ⊗

1 ⊗

1 ⊗

1 ⊗

1 ⊗

1 ⊗

1 ⊗

1 ⊗

1 ⊗

1 ⊗

1 ⊗

ZKS **586.360**

WHT 005 262 A (8x)

M 12x1,5x175

2x



311.140

059 103 483 T

Cyl. 4-6

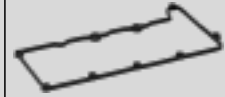

311.160

059 103 484

Cyl. 1-3

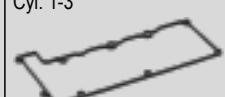











323.480

059 103 085 L

6x

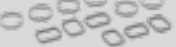

			<p>a) </p> <p>b) </p>	<p>K: </p> <p>N: </p>	
<p>VAS 235.650 FPM 724.590 036 109 675 A FPM 24x</p>	<p>048.800 059 253 039 N 2x </p>	<p>AAS 427.130 </p>	<p>a) 030.793 Dirko HT</p> <p>b) 858.050 N 911 679 01 incl. 591.840 M 14x1,5x15</p> <p>b) 591.840 N 013 815.8 Metal C 14x20x2</p> <p>b) 813.036 N 013 815.6 CU C 14x20x2</p>	<p>K:← 263.600 079 103 051 D ASW RD PTFE/ACM 55x70x8</p> <p>K:→ 331.330 059 103 051 K ASW OF LD FPM 85x105x8</p>	<p>TLS 311.330 </p>

AUDI

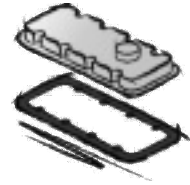
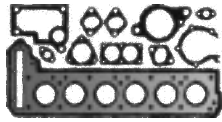

CLAB

6 Cyl. **2967 ccm**
Cyl. 83,0 ∅

A4 TDI

11/2011 → 12/2015

A5 TDI

10/2011 → 01/2017

A6 TDI

11/2010 → 09/2018

A7 TDI

11/2010 → 03/2015

A8 TDI

09/2011 → 09/2013

ES⊕ **323.520**



CS* **339.380**
A8 4H2/4H8

A7 4GA/4GF
A6 4G2/4G5
→02/2013

A4 8K2/8K5
A5 8T3/8F7
→04/2013

CS* **341.000**
A6 4G2/4G5
A7 4GA/4GF
02/2013→

A5 8T3/8F7
A4 8K2/8K5
04/2013→

OKS **908.400**

OKS **526.820**

299.800

059 103 383 KP

0,820 mm

→ 0,920 mm

1,58 mm $\frac{+}{-}$ 84 ∅

L

1 ⊗

299.810

059 103 383 KQ

0,920 mm

→ 0,970 mm

1,63 mm $\frac{+}{-}$ 84 ∅

L

2 ⊗

299.820

059 103 383 KR

0,970 mm

→ 1,080 mm

1,68 mm $\frac{+}{-}$ 84 ∅

L

3 ⊗

299.720

059 103 383 KL

0,820 mm

→ 0,920 mm

1,58 mm $\frac{+}{-}$ 84 ∅

R

1 ⊗

299.780

059 103 383 KM

0,920 mm

→ 0,970 mm

1,63 mm $\frac{+}{-}$ 84 ∅

R

2 ⊗

299.790

059 103 383 KN

0,970 mm

→ 1,080 mm

1,68 mm $\frac{+}{-}$ 84 ∅

R

3 ⊗

ZKS **586.360**

WHT 005 262 A (8x)

M 12x1,5x175

2x

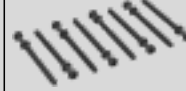

311.140

059 103 483 T

Cyl. 4-6

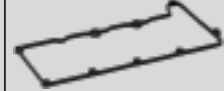

311.160

059 103 484

Cyl. 1-3













323.480

059 103 085 L

6x

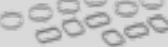

			<p>a) </p> <p>b) </p>	<p>K: </p> <p>N: </p>	
<p>VAS 235.650 FPM 724.590 036 109 675 A FPM 24x</p>	<p>048.800 059 253 039 N 2x </p>	<p>AAS 427.130 </p>	<p>a) 030.793 Dirko HT</p> <p>b) 858.050 N 911 679 01 incl. 591.840 M 14x1,5x15</p> <p>b) 591.840 N 013 815.8 Metal C 14x20x2</p> <p>b) 813.036 N 013 815.6 CU C 14x20x2</p>	<p>K:← 263.600 079 103 051 D ASW RD PTFE/ACM 55x70x8</p> <p>K:→ 331.330 059 103 051 K ASW OF LD FPM 85x105x8</p>	<p>TLS 311.330 </p>

AUDI

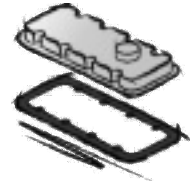
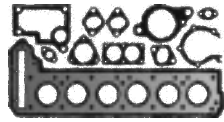

CDTA CDTB
CDTC CMHA
CPNA

6 Cyl. 2967 ccm
Cyl. 83,0 Ø

A8 TDI
07/2010 → 01/2018

ES⊕ 323.520



CS* 339.380
OKS 908.400
OKS 526.820

299.800

059 103 383 KP
0,820 mm
→
0,920 mm
1,58 mm $\frac{+}{-}$ 84 Ø
L
1 ⊗



299.810

059 103 383 KQ
0,920 mm
→
0,970 mm
1,63 mm $\frac{+}{-}$ 84 Ø
L
2 ⊗



299.820

059 103 383 KR
0,970 mm
→
1,080 mm
1,68 mm $\frac{+}{-}$ 84 Ø
L
3 ⊗



299.720

059 103 383 KL
0,820 mm
→
0,920 mm
1,58 mm $\frac{+}{-}$ 84 Ø
R
1 ⊗



299.780

059 103 383 KM
0,920 mm
→
0,970 mm
1,63 mm $\frac{+}{-}$ 84 Ø
R
2 ⊗



299.790

059 103 383 KN
0,970 mm
→
1,080 mm
1,68 mm $\frac{+}{-}$ 84 Ø
R
3 ⊗

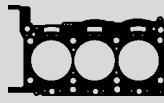

ZKS 586.360

WHT 005 262 A (8x)
M 12x1,5x175
2x

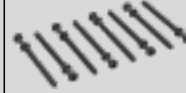

311.140

059 103 483 T
Cyl. 4-6

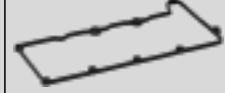

311.160



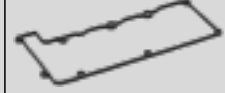







059 103 484
Cyl. 1-3



323.480

059 103 085 L
6x

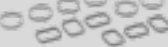

			<p>a) </p> <p>b) </p>	<p>K: </p> <p>N: </p>	
<p>VAS 235.650 FPM 724.590 036 109 675 A FPM 24x</p>	<p>048.800 059 253 039 N 2x </p>	<p>AAS 427.130 </p>	<p>a) 030.793 Dirko HT</p> <p>b) 858.050 N 911 679 01 incl. 591.840 M 14x1,5x15</p> <p>b) 591.840 N 013 815.8 Metal C 14x20x2</p> <p>b) 813.036 N 013 815.6 CU C 14x20x2</p>	<p>K:← 263.600 079 103 051 D ASW RD PTFE/ACM 55x70x8</p> <p>K:→ 331.330 059 103 051 K ASW OF LD FPM 85x105x8</p>	<p>TLS 311.330 </p>

AUDI



CPNB CTBA
CTBB CTBC
CTBD CTCB
CTCC

6 Cyl. 2967 ccm
Cyl. 83,0 Ø

A6 TDI
05/2013 → 09/2018

A7 TDI
05/2013 → 05/2018

A8 TDI
08/2010 → 01/2018

Q5 TDI
11/2008 → 05/2017

ES⊕ **323.520**



CS* **341.000**
OKS **908.400**
OKS **526.820**

299.800

059 103 383 KP

0,820 mm
→
0,920 mm

1,58 mm $\frac{+}{-}$ 84 Ø

L

1 ⊗

299.810

059 103 383 KQ

0,920 mm
→
0,970 mm

1,63 mm $\frac{+}{-}$ 84 Ø

L

2 ⊗

299.820

059 103 383 KR

0,970 mm
→
1,080 mm

1,68 mm $\frac{+}{-}$ 84 Ø

L

3 ⊗

299.720

059 103 383 KL

0,820 mm
→
0,920 mm

1,58 mm $\frac{+}{-}$ 84 Ø

R

1 ⊗

299.780

059 103 383 KM

0,920 mm
→
0,970 mm

1,63 mm $\frac{+}{-}$ 84 Ø

R

2 ⊗

299.790

059 103 383 KN

0,970 mm
→
1,080 mm

1,68 mm $\frac{+}{-}$ 84 Ø

R

3 ⊗

ZKS **586.360**

WHT 005 262 A (8x)
M 12x1,5x175
2x



311.140

059 103 483 T
Cyl. 4-6

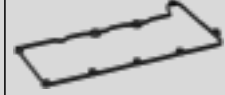

311.160



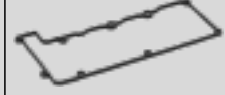







059 103 484
Cyl. 1-3



323.480

059 103 085 L
6x

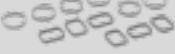

			<p>a) </p> <p>b) </p>	<p>K: </p> <p>N: </p>	
<p>VAS 235.650 FPM 724.590 036 109 675 A FPM 24x</p>	<p>048.800 059 253 039 N 2x </p>	<p>AAS 427.130 </p>	<p>a) 030.793 Dirko HT</p> <p>b) 858.050 N 911 679 01 incl. 591.840 M 14x1,5x15</p> <p>b) 591.840 N 013 815.8 Metal C 14x20x2</p> <p>b) 813.036 N 013 815.6 CU C 14x20x2</p>	<p>K:← 263.600 079 103 051 D ASW RD PTFE/ACM 55x70x8</p> <p>K:→ 331.330 059 103 051 K ASW OF LD FPM 85x105x8</p>	<p>TLS 311.330 </p>

AUDI

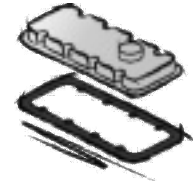
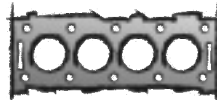
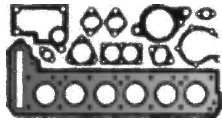

CRTC **CRTD**
CRTF **CSWB**
CUEA **CVMD**
CZVA **CZVB**
CZVC **CZVD**
CZVE **CZVF**
CZZA

6 Cyl. **2967 ccm**
Cyl. 83,0 ∅

- A4 Allroad TDI**
01/2016 → 08/2018
- A4 TDI**
05/2015 → 08/2018
- A5 TDI**
07/2016 →
- A6 Allroad TDI**
09/2014 →
- A6 TDI**
09/2014 →
- A7 TDI**
05/2014 → 05/2018
- A8 TDI**
01/2019 →
- Q7 TDI**
01/2015 →
- Q8 TDI**
02/2018 →

ES⊕ 693.580

CS* 766.940
 →12/2015
CS* 928.780
 12/2015→

227.981
 059 103 149 AJ
 0,810 mm
 →
 0,910 mm
 1,60 mm $\frac{1}{2}$ 84,3 ∅
 L
 1 ⊗

227.991
 059 103 149 AK
 0,910 mm
 →
 0,960 mm
 1,65 mm $\frac{1}{2}$ 84,3 ∅
 L
 2 ⊗



228.001
 059 103 149 AL
 0,960 mm
 →
 1,070 mm
 1,70 mm $\frac{1}{2}$ 84,3 ∅
 L
 3 ⊗

227.961
 059 103 148 AK
 0,910 mm
 →
 0,960 mm
 1,65 mm $\frac{1}{2}$ 84,3 ∅
 R
 2 ⊗

227.971
 059 103 148 AL
 0,960 mm
 →
 1,070 mm
 1,70 mm $\frac{1}{2}$ 84,3 ∅
 R
 3 ⊗



227.951
 059 103 148 AJ
 0,810 mm
 →
 0,910 mm
 1,60 mm $\frac{1}{2}$ 84,3 ∅
 R Cyl. 1-3
 1 ⊗

ZKS 586.360
 WHT 005 262 A (8x)
 M 12x1,5x175
 2x

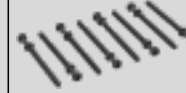

456.180
 059 103 484 E
 Cyl. 1-3

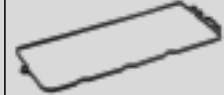











456.220
 059 103 484 AE
 Cyl. 4-6



323.480
 059 103 085 L
 6x



			<p>a) </p> <p>b) </p>	<p>K: </p> <p>N: </p>	
<p>VAS 235.650 FPM 724.590 036 109 675 A FPM E 12x 797.560 06L 09 675 C FPM A 12x</p>	<p>225.060 059 253 039 AF 2x</p> 	<p>AAS 086.420</p> 	<p>a) 030.793 Dirko HT</p> <p>b) 858.050 N 911 679 01 incl. 591.840 M 14x1,5x15</p> <p>b) 591.840 N 013 815.8 Metal C 14x20x2</p> <p>b) 813.036 N 013 815.6 CU C 14x20x2</p>	<p>K:← 263.600 079 103 051 D ASW RD PTFE/ACM 55x70x8</p> <p>K:→ 331.330 059 103 051 K ASW OF LD FPM 85x105x8</p>	<p>TLS 793.380</p> 

AUDI

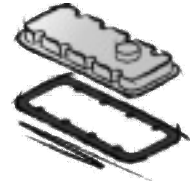
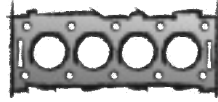
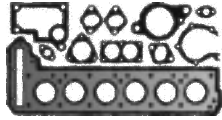

CVUA CVUB
CVUC

6 Cyl. **2967 ccm**
Cyl. 83,0 Ø

A6 Allroad TDI
01/2012 → 09/2018

A6 TDI
09/2014 → 09/2018

A7 TDI
05/2014 → 05/2018

Q5 TDI
12/2012 → 05/2017

245.650
059 103 149 AC
1,59 mm $\frac{1}{16}$ 84,3 Ø
L
1 ⊗

245.660
059 103 149 AD
1,64 mm $\frac{1}{16}$ 84,3 Ø
L
2 ⊗

245.670
059 103 149 AE
1,69 mm $\frac{1}{16}$ 84,3 Ø
L
3 ⊗

245.620
059 103 148 AC
1,59 mm $\frac{1}{16}$ 84,3 Ø
R
1 ⊗

245.630
059 103 148 AD
1,64 mm $\frac{1}{16}$ 84,3 Ø
R
2 ⊗

245.640
059 103 148 AE
1,69 mm $\frac{1}{16}$ 84,3 Ø
R
3 ⊗

ZKS 586.360
WHT 005 262 A (8x)
M 12x1,5x175
2x



311.140
059 103 483 T
Cyl. 4-6

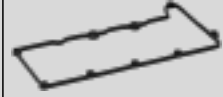









311.160
059 103 484
Cyl. 1-3



323.480
059 103 085 L
6x

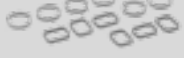

AUDI

			<p>a) </p> <p>b) </p>	<p>K: </p> <p>N: </p>	
<p>VAS 235.650 FPM 724.590 036 109 675 A FPM 24x</p>	<p>121.610 059 253 039 Q 2x</p> 	<p>AAS 427.130</p> 	<p>a) 030.793 Dirko HT</p> <p>b) 858.050 N 911 679 01 incl. 591.840 M 14x1,5x15</p> <p>b) 982.340 N 016 027 6 incl. 813.036 M 14x1,5x12</p> <p>b) 591.840 N 013 815.8 Metal C 14x20x2</p> <p>b) 813.036 N 013 815.6 CU C 14x20x2</p>	<p>K:← 263.600 079 103 051 D ASW RD PTFE/ACM 55x70x8</p> <p>K:→ 331.330 059 103 051 K ASW OF LD FPM 85x105x8</p>	

AUDI

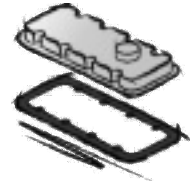
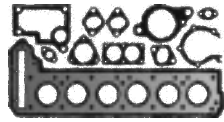

CVZA

6 Cyl. **2967 ccm**
Cyl. 83,0 Ø

Q7 TDI

08/2015 → 12/2019

ES⊕ **693.580**



CS* **766.940**

→12/2015

CS* **928.780**

12/2015→

227.981

059 103 149 AJ

0,810 mm



→ 0,910 mm

1,60 mm $\frac{1}{2}$ 84,3 Ø

L

1 ⊗

227.991

059 103 149 AK

0,910 mm



→ 0,960 mm

1,65 mm $\frac{1}{2}$ 84,3 Ø

L

2 ⊗



228.001

059 103 149 AL

0,960 mm



→ 1,070 mm

1,70 mm $\frac{1}{2}$ 84,3 Ø

L

3 ⊗

227.961

059 103 148 AK

0,910 mm



→ 0,960 mm

1,65 mm $\frac{1}{2}$ 84,3 Ø

R

2 ⊗

227.971

059 103 148 AL

0,960 mm



→ 1,070 mm

1,70 mm $\frac{1}{2}$ 84,3 Ø

R

3 ⊗



227.951

059 103 148 AJ

0,810 mm



→ 0,910 mm

1,60 mm $\frac{1}{2}$ 84,3 Ø

R Cyl. 1-3

1 ⊗

ZKS **586.360**

WHT 005 262 A (8x)

M 12x1,5x175

2x

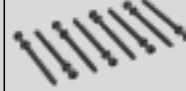

456.180

059 103 484 E

Cyl. 1-3

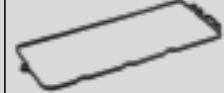

456.220

059 103 483 AE

Cyl. 4-6













323.480

059 103 085 L

6x



			<p>a) </p> <p>b) </p>	<p>K: </p> <p>N: </p>	
<p>VAS 235.650 FPM 724.590 036 109 675 A FPM E 12x 797.560 06L 09 675 C FPM A 12x</p>	<p>225.060 059 253 039 AF 2x </p>	<p>AAS 086.420 </p>	<p>a) 030.793 Dirko HT b) 591.840 N 013 815.8 Metal C 14x20x2 b) 813.036 N 013 815.6 CU C 14x20x2</p>	<p>K:← 263.600 079 103 051 D ASW RD PTFE/ACM 55x70x8 K:→ 331.330 059 103 051 K ASW OF LD FPM 85x105x8</p>	<p>TLS 793.380 </p>

AUDI



CRTE
CZZB
6 Cyl. **2967 ccm**
Cyl. 83,0 Ø

A6 Allroad TDI
09/2014 → 09/2018

A6 TDI
09/2014 → 09/2018

A7 TDI
07/2014 → 05/2018

Q7 TDI
05/2015 → 12/2019

ES⊕ **693.580**



CS* **766.940**
→12/2015

227.981

059 103 149 AJ
 0,810 mm
 →
 0,910 mm
 1,60 mm $\frac{+}{-}$ 84,3 Ø
 L
 1 ⊗

227.991

059 103 149 AK
 0,910 mm
 →
 0,960 mm
 1,65 mm $\frac{+}{-}$ 84,3 Ø
 L
 2 ⊗



228.001

059 103 149 AL
 0,960 mm
 →
 1,070 mm
 1,70 mm $\frac{+}{-}$ 84,3 Ø
 L
 3 ⊗

227.961

059 103 148 AK
 0,910 mm
 →
 0,960 mm
 1,65 mm $\frac{+}{-}$ 84,3 Ø
 R
 2 ⊗

227.971

059 103 148 AL
 0,960 mm
 →
 1,070 mm
 1,70 mm $\frac{+}{-}$ 84,3 Ø
 R
 3 ⊗



227.951

059 103 148 AJ
 0,810 mm
 →
 0,910 mm
 1,60 mm $\frac{+}{-}$ 84,3 Ø
 R Cyl. 1-3
 1 ⊗

ZKS **586.360**

WHT 005 262 A (8x)
 M 12x1,5x175
 2x



456.180

059 103 484 E
 Cyl. 1-3

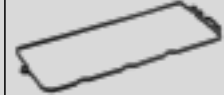

456.220



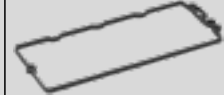







059 103 483 AE
 Cyl. 4-6



323.480

059 103 085 L
 6x



			<p>a) </p> <p>b) </p>	<p>K: </p> <p>N: </p>	
<p>VAS 235.650 FPM 724.590 036 109 675 A FPM E 12x 797.560 06L 09 675 C FPM A 12x</p>	<p>225.060 059 253 039 AF 2x </p>	<p>AAS 086.420 </p>	<p>a) 030.793 Dirko HT b) 858.050 N 911 679 01 incl. 591.840 M 14x1,5x15 b) 591.840 N 013 815.8 Metal C 14x20x2 b) 813.036 N 013 815.6 CU C 14x20x2</p>	<p>K:← 263.600 079 103 051 D ASW RD PTFE/ACM 55x70x8 K:→ 331.330 059 103 051 K ASW OF LD FPM 85x105x8</p>	<p>TLS 793.380 </p>

AUDI

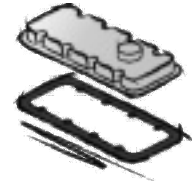
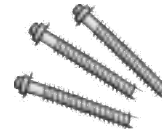
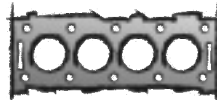
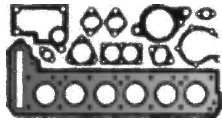

DCPC
DCPE

6 Cyl. **2967 ccm**
Cyl. 83,0 Ø

A4 Allroad TDI
07/2018 →

A4 TDI
07/2018 → 11/2019

A5 TDI
11/2016 → 02/2020

Q5 TDI
07/2017 → 11/2020

ES⊕ **636.250**



CS* **928.780**

227.981

059 103 149 AJ
 0,810 mm
 →
 0,910 mm
 1,60 mm $\frac{2}{3}$ 84,3 Ø
 L
 1 ⊗

227.991

059 103 149 AK
 0,910 mm
 →
 0,960 mm
 1,65 mm $\frac{2}{3}$ 84,3 Ø
 L
 2 ⊗



228.001

059 103 149 AL
 0,960 mm
 →
 1,070 mm
 1,70 mm $\frac{2}{3}$ 84,3 Ø
 L
 3 ⊗

227.961

059 103 148 AK
 0,910 mm
 →
 0,960 mm
 1,65 mm $\frac{2}{3}$ 84,3 Ø
 R
 2 ⊗

227.971

059 103 148 AL
 0,960 mm
 →
 1,070 mm
 1,70 mm $\frac{2}{3}$ 84,3 Ø
 R
 3 ⊗



227.951

059 103 148 AJ
 0,810 mm
 →
 0,910 mm
 1,60 mm $\frac{2}{3}$ 84,3 Ø
 R Cyl. 1-3
 1 ⊗

ZKS **586.360**

WHT 005 262 A (8x)
 M 12x1,5x175
 2x

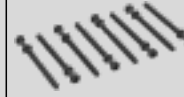

954.350

059 103 483 AG
 Cyl. 4-6











954.360

059 103 484 H
 Cyl. 1-3

323.480

059 103 085 L
 6x



			<p>a) </p> <p>b) </p>	<p>K: </p> <p>N: </p>	
<p>VAS 235.650 FPM 724.590 036 109 675 A FPM E 12x 797.560 06L 09 675 C FPM A 12x</p>	<p>225.060 059 253 039 AF 2x </p>		<p>a) 030.793 Dirko HT</p> <p>b) 591.840 N 013 815.8 Metal C 14x20x2</p> <p>b) 813.036 N 013 815.6 CU C 14x20x2</p>	<p>K:← 263.600 079 103 051 D ASW RD PTFE/ACM 55x70x8</p> <p>K:→ 331.330 059 103 051 K ASW OF LD FPM 85x105x8</p>	<p>TLS 793.380 </p>

AUDI

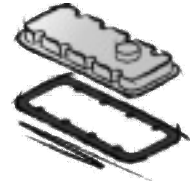
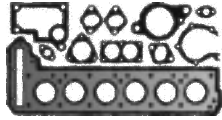

DEHA

6 Cyl. 2967 ccm
Cyl. 83,0 Ø

Q5 TDI

11/2015 → 05/2017

245.650
059 103 149 AC
1,59 mm $\frac{+}{-}$ 84,3 Ø
L
1 ⊗

245.660
059 103 149 AD
1,64 mm $\frac{+}{-}$ 84,3 Ø
L
2 ⊗

245.670
059 103 149 AE
1,69 mm $\frac{+}{-}$ 84,3 Ø
L
3 ⊗

245.620
059 103 148 AC
1,59 mm $\frac{+}{-}$ 84,3 Ø
R
1 ⊗

245.630
059 103 148 AD
1,64 mm $\frac{+}{-}$ 84,3 Ø
R
2 ⊗

245.640
059 103 148 AE
1,69 mm $\frac{+}{-}$ 84,3 Ø
R
3 ⊗

ZKS 586.360
WHT 005 262 A (8x)
M 12x1,5x175
2x



311.140
059 103 483 T
Cyl. 4-6

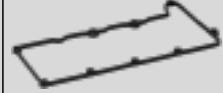









311.160
059 103 484
Cyl. 1-3



323.480
059 103 085 L
6x

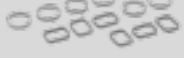

AUDI

			<p>a) </p> <p>b) </p>	<p>K: </p> <p>N: </p>	
<p>VAS 235.650 FPM 724.590 036 109 675 A FPM 24x</p>	<p>121.610 059 253 039 Q 2x</p> 	<p>AAS 427.130</p> 	<p>a) 030.793 Dirko HT</p> <p>b) 858.050 N 911 679 01 incl. 591.840 M 14x1,5x15</p> <p>b) 591.840 N 013 815.8 Metal C 14x20x2</p> <p>b) 813.036 N 013 815.6 CU C 14x20x2</p>	<p>K:← 263.600 079 103 051 D ASW RD PTFE/ACM 55x70x8</p> <p>K:→ 331.330 059 103 051 K ASW OF LD FPM 85x105x8</p>	

AUDI

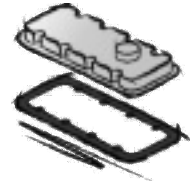

DEWA
DEWB
6 Cyl. 2967 ccm
Cyl. 83,0 Ø

- A4 S4 TDI**
05/2019 →
- A5 TDI**
12/2018 → 02/2020
- A6 Allroad TDI**
03/2019 →
- A6 TDI**
03/2019 →
- A7 S7 TDI**
03/2019 →
- Q5 TDI**
02/2019 →

ES⊕ **636.250**

CS* **928.780**

523.340
 0,810 mm
→
0,910 mm
1,60 mm ± 84,3 Ø
L
1 ⊗

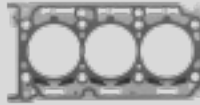

523.350
 0,910 mm
→
0,960 mm
1,65 mm ± 84,3 Ø
L
2 ⊗

523.360
 0,960 mm
→
1,070 mm
1,70 mm ± 84,3 Ø
L
3 ⊗



523.310
 0,810 mm
→
0,910 mm
1,60 mm ± 84,3 Ø
R
1 ⊗



523.320
 0,910 mm
→
0,960 mm
1,65 mm ± 84,3 Ø
R
2 ⊗

523.330
 0,960 mm
→
1,070 mm
1,70 mm ± 84,3 Ø
R
3 ⊗





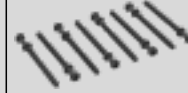





ZKS 586.360
WHT 005 262 A (8x)
M 12x1,5x175
2x



954.350
059 103 483 AG
Cyl. 4-6
954.360
059 103 484 H
Cyl. 1-3

AUDI

			<p>a) </p> <p>b) </p>	<p>K: </p> <p>N: </p>	
<p>724.590 036 109 675 A FPM E 12x</p> <p>797.560 06L 09 675 C FPM A 12x</p>	<p>225.060 059 253 039 AF 2x</p> 		<p>a) 030.793 Dirko HT</p> <p>b) 243.205 N 013 849.3 AL A 14x20x1,5</p>	<p>K:← 263.600 079 103 051 D ASW RD PTFE/ACM 55x70x8</p> <p>K:→ 331.330 059 103 051 K ASW OF LD FPM 85x105x8</p>	

AUDI

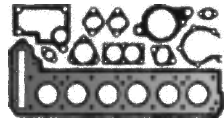

DDVB DDVC
DDVE DDVF
DHXA DHXC
DPXA DPXB

6 Cyl. **2967 ccm**
Cyl. 83,0 Ø

A6 Allroad TDI
11/2018 →

A6 TDI
02/2018 →

A7 TDI
10/2017 →

A8 TDI
06/2017 →

Q7 TDI
07/2018 → 12/2019

Q8 TDI
07/2018 →

ES⊕ **636.250**



CS* **928.780**

227.981

059 103 149 AJ
 0,810 mm
 →
 0,910 mm
 1,60 mm $\frac{+}{-}$ 84,3 Ø
 L
 1 ⊗

227.991

059 103 149 AK
 0,910 mm
 →
 0,960 mm
 1,65 mm $\frac{+}{-}$ 84,3 Ø
 L
 2 ⊗



228.001

059 103 149 AL
 0,960 mm
 →
 1,070 mm
 1,70 mm $\frac{+}{-}$ 84,3 Ø
 L
 3 ⊗

227.961

059 103 148 AK
 0,910 mm
 →
 0,960 mm
 1,65 mm $\frac{+}{-}$ 84,3 Ø
 R
 2 ⊗

227.971

059 103 148 AL
 0,960 mm
 →
 1,070 mm
 1,70 mm $\frac{+}{-}$ 84,3 Ø
 R
 3 ⊗



227.951

059 103 148 AJ
 0,810 mm
 →
 0,910 mm
 1,60 mm $\frac{+}{-}$ 84,3 Ø
 R Cyl. 1-3
 1 ⊗

ZKS **586.360**

WHT 005 262 A (8x)
 M 12x1,5x175
 2x



954.350

059 103 483 AG
 Cyl. 4-6

954.360

059 103 484 H
 Cyl. 1-3

323.480

059 103 085 L
 6x



ASN AVK
BBJ BGN

6 Cyl. **2976 ccm**
Cyl. 82,5 Ø

A4
11/2000 → 07/2006

A6
06/2001 → 05/2006

A8
07/2003 → 05/2006

ES⊕ **430.181**
2x

627.651

06C 103 383 H
 0,90 mm $\frac{+}{-}$ 83 Ø
 2x



ZKS **057.450**













06B 103 385 (8x)
 M 12x1,5x132
 2x











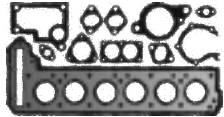
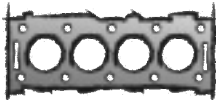

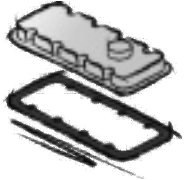

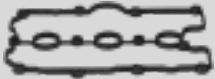
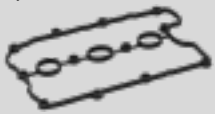





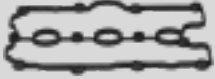
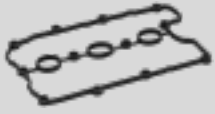





493.460

06C 103 483 J
 2x



			<p>a) </p> <p>b) </p>	<p>K: </p> <p>N: </p>	
<p>VAS 235.650 FPM 724.590 036 109 675 A FPM 24x</p>	<p>225.060 059 253 039 AF 2x </p>		<p>a) 030.793 Dirko HT</p> <p>b) 858.050 N 911 679 01 incl. 591.840 M 14x1,5x15</p> <p>b) 591.840 N 013 815.8 Metal C 14x20x2</p> <p>b) 813.036 N 013 815.6 CU C 14x20x2</p>	<p>K:← 263.600 079 103 051 D ASW RD PTFE/ACM 55x70x8</p> <p>K:→ 331.330 059 103 051 K ASW OF LD FPM 85x105x8</p>	<p>TLS 793.380 </p>
<p>VAS 057.070 FPM 724.590 036 109 675 A FPM 30x</p>	<p>433.250 078 253 039 G 2x </p>	<p>413.900 078 129 717 J 2x </p>	<p>a) 030.793 Dirko HT</p> <p>b) 567.640 N 908 132 01 M 14x1,5x22</p>	<p>K:← 155.560 038 103 085 E ASW RD PTFE/ACM 35x48x10</p> <p>N:← 655.340 06C 103 085 AW/BS RD PTFE/ACM 42x55x7 4x</p>	

AUDI					
					
CAKA CGWA CGWC CGXA CGXC CHMB CTUB	CCBA CGWB CGWD CGXB CHMA CMDA	ES⊕ 340.590 CS* 783.930	323.330 06E 103 148 AG 85,2 Ø Cyl. 1-3 323.370 06E 103 149 AG 85,2 Ø Cyl. 4-6	ZKS 325.040 06E 103 385 E (8x) M 10x1,5x172 →07/2011 2x  ZKS 223.890 WHT 005 739 (8x) M 10x1,5x170 07/2011→ 2x 	461.682 EL-Liq 74 ↓ 429.910 06E 103 483 Q Cyl. 4-6  429.980 06E 103 484 P Cyl. 1-3 
A4 S4 11/2008 → 12/2015 A5 12/2011 → 01/2017 A5 S5 06/2009 → 01/2017 A6 11/2010 → 09/2018 A6 Allroad 01/2012 → 12/2014 A7 10/2010 → 03/2015 A8 06/2010 → 01/2018					
CJTB CJWB CJWE	CJTC CJWC	ES⊕ 340.590	323.330 06E 103 148 AG 85,2 Ø Cyl. 1-3 323.370 06E 103 149 AG 85,2 Ø Cyl. 4-6	ZKS 325.040 06E 103 385 E (8x) M 10x1,5x172 →07/2011 2x  ZKS 223.890 WHT 005 739 (8x) M 10x1,5x170 07/2011→ 2x 	461.682 EL-Liq 74 ↓ 429.910 06E 103 483 Q Cyl. 4-6  429.980 06E 103 484 P Cyl. 1-3 
Q7 05/2010 → 08/2015					
CAJA CNA A CTWB	CCAA CTWA	ES⊕ 340.590	323.330 06E 103 148 AG 85,2 Ø Cyl. 1-3 323.370 06E 103 149 AG 85,2 Ø Cyl. 4-6	ZKS 325.040 06E 103 385 E (8x) M 10x1,5x172 →07/2011 2x  ZKS 223.890 WHT 005 739 (8x) M 10x1,5x170 07/2011→ 2x 	461.682 EL-Liq 74 ↓ 429.910 06E 103 483 Q Cyl. 4-6  429.980 06E 103 484 P Cyl. 1-3 
A6 10/2008 → 05/2012 A6 Allroad 10/2008 → 08/2011 Q7 05/2010 → 08/2015					

			<p>a) </p> <p>b) </p>	<p>K: </p> <p>N: </p>	
<p>VAS 235.650 FPM 724.590 036 109 675 A FPM 24x</p>	<p>724.250 06E 253 039 C 2x </p>	<p>225.170 079 129 717 B 6x </p>	<p>a) 030.793 Dirko HT b) 982.340 N 016 027 6 incl. 813.036 M 14x1,5x12 b) 591.840 N 013 815.8 Metal C 14x20x2 b) 813.036 N 013 815.6 CU C 14x20x2</p>	<p>K:← 728.550 06E 103 153 E SP RD PTFE 45x60 K:→ 026.790 079 103 051 F ASW LD PTFE/FPM 85x105x8,8 K:→ 331.330 059 103 051 K ASW OF LD FPM 85x105x8</p>	<p>TLS 796.460</p>
<p>VAS 235.650 FPM 724.590 036 109 675 A FPM 24x</p>	<p>724.250 06E 253 039 C 2x </p>	<p>225.170 079 129 717 B 6x </p>	<p>a) 030.793 Dirko HT b) 982.340 N 016 027 6 incl. 813.036 M 14x1,5x12 b) 591.840 N 013 815.8 Metal C 14x20x2 b) 813.036 N 013 815.6 CU C 14x20x2</p>	<p>K:← 728.550 06E 103 153 E SP RD PTFE 45x60 K:→ 026.790 079 103 051 F ASW LD PTFE/FPM 85x105x8,8</p>	<p>TLS 796.460</p>
<p>VAS 235.650 FPM 724.590 036 109 675 A FPM 24x</p>	<p>724.250 06E 253 039 C 2x </p>	<p>225.170 079 129 717 B 6x </p>	<p>a) 030.793 Dirko HT b) 982.340 N 016 027 6 incl. 813.036 M 14x1,5x12 b) 591.840 N 013 815.8 Metal C 14x20x2 b) 813.036 N 013 815.6 CU C 14x20x2</p>	<p>K:← 728.550 06E 103 153 E SP RD PTFE 45x60 K:→ 026.790 079 103 051 F ASW LD PTFE/FPM 85x105x8,8 K:→ 331.330 059 103 051 K ASW OF LD FPM 85x105x8</p>	<p>TLS 796.460</p>

AUDI

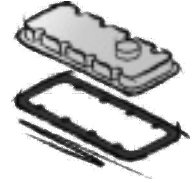
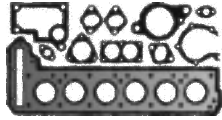

CREC

6 Cyl. **2995 ccm**
Cyl. 84,5 Ø

A4 S4
11/2008 → 12/2015

A5 S5
06/2009 → 01/2017

A6
09/2014 → 09/2018

A6 Allroad
09/2014 → 09/2018

A7
05/2014 → 05/2018

A8
06/2010 → 01/2018

Q7
01/2015 → 12/2019

ES⊕ **340.590**
A5 8T3/8F7
A4 8K2/8K5

323.330
06E 103 148 AG
85,2 Ø

Cyl. 1-3
A5 8T3/8F7
A4 8K2/8K5

323.370
06E 103 149 AG
85,2 Ø

Cyl. 4-6
A4 8K2/8K5
A5 8T3/8F7

796.160
06E 103 148 AR
0,85 mm ± 85,2 Ø
Cyl. 1-3

796.170
06E 103 149 AR
0,85 mm ± 85,2 Ø
Cyl. 4-6

ZKS 223.890
WHT 005 739 (8x)
M 10x1,5x170
2x

461.682
EL-Liq 74
↓
429.910
06E 103 483 Q
Cyl. 4-6

429.980
06E 103 484 P
Cyl. 1-3

CREC

6 Cyl. **2995 ccm**
Cyl. 84,5 Ø

A4
02/2012 → 12/2015

A5
11/2011 → 01/2017

ES⊕ **340.590**
A4 8K2/8K5
A5 8T3/8F7

323.330
06E 103 148 AG
85,2 Ø

Cyl. 1-3
A4 8K2/8K5
A5 8T3/8F7

323.370
06E 103 149 AG
85,2 Ø

Cyl. 4-6
A5 8T3/8F7
A4 8K2/8K5

ZKS 223.890
WHT 005 739 (8x)
M 10x1,5x170
2x

461.682
EL-Liq 74
↓
429.910
06E 103 483 Q
Cyl. 4-6

429.980
06E 103 484 P
Cyl. 1-3

CREA **CREG**
CREH

6 Cyl. **2995 ccm**
Cyl. 84,5 Ø

A6
09/2016 → 09/2018

A7
05/2016 → 05/2018

A8
07/2010 → 01/2018

796.160
06E 103 148 AR
0,85 mm ± 85,2 Ø
Cyl. 1-3

796.170
06E 103 149 AR
0,85 mm ± 85,2 Ø
Cyl. 4-6

796.160
06E 103 148 AR
0,85 mm ± 85,2 Ø
Cyl. 1-3











796.170
06E 103 149 AR
0,85 mm ± 85,2 Ø
Cyl. 4-6

ZKS 223.890
WHT 005 739 (8x)
M 10x1,5x170
2x

461.682
EL-Liq 74
↓
429.910
06E 103 483 Q
Cyl. 4-6

429.980
06E 103 484 P
Cyl. 1-3

AUDI

			<p>a) </p> <p>b) </p>	<p>K: </p> <p>N: </p>	
<p>VAS 235.650 FPM 724.590 036 109 675 A FPM 24x</p>	<p>724.250 06E 253 039 C 2x </p>	<p>858.060 06E 129 717 F 6x</p>	<p>a) 030.793 Dirko HT</p> <p>b) 858.050 N 911 679 01 incl. 591.840 M 14x1,5x15</p> <p>b) 982.340 N 016 027 6 incl. 813.036 M 14x1,5x12</p> <p>b) 591.840 N 013 815.8 Metal C 14x20x2</p> <p>b) 813.036 N 013 815.6 CU C 14x20x2</p>	<p>K:← 728.550 06E 103 153 E SP RD PTFE 45x60</p> <p>K:→ 026.790 079 103 051 F ASW LD PTFE/FPM 85x105x8,8</p>	
<p>VAS 235.650 FPM 724.590 036 109 675 A FPM 24x</p>	<p>724.250 06E 253 039 C 2x </p>	<p>858.060 06E 129 717 F 6x</p>	<p>a) 030.793 Dirko HT</p> <p>b) 858.050 N 911 679 01 incl. 591.840 M 14x1,5x15</p> <p>b) 982.340 N 016 027 6 incl. 813.036 M 14x1,5x12</p> <p>b) 591.840 N 013 815.8 Metal C 14x20x2</p> <p>b) 813.036 N 013 815.6 CU C 14x20x2</p>	<p>K:← 728.550 06E 103 153 E SP RD PTFE 45x60</p> <p>K:→ 026.790 079 103 051 F ASW LD PTFE/FPM 85x105x8,8</p>	
<p>VAS 235.650 FPM 724.590 036 109 675 A FPM 24x</p>	<p>724.250 06E 253 039 C 2x </p>	<p>858.060 06E 129 717 F 6x</p>	<p>a) 030.793 Dirko HT</p> <p>b) 858.050 N 911 679 01 incl. 591.840 M 14x1,5x15</p> <p>b) 982.340 N 016 027 6 incl. 813.036 M 14x1,5x12</p> <p>b) 591.840 N 013 815.8 Metal C 14x20x2</p> <p>b) 813.036 N 013 815.6 CU C 14x20x2</p>	<p>K:← 728.550 06E 103 153 E SP RD PTFE 45x60</p> <p>K:→ 026.790 079 103 051 F ASW LD PTFE/FPM 85x105x8,8</p>	

AUDI

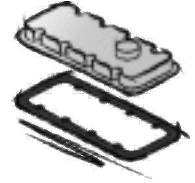
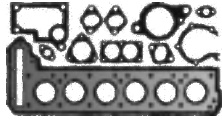

CTDA

6 Cyl. **2995 ccm**
Cyl. 84,5 Ø

A5 S5
06/2009 → 01/2017

A8
06/2010 → 01/2018

ES⊕ **340.590**
A5 8T3/8F7

323.330
06E 103 148 AG
85,2 Ø

Cyl. 1-3
A5 8T3/8F7

323.370
06E 103 149 AG
85,2 Ø

Cyl. 4-6
A5 8T3/8F7

796.160
06E 103 148 AR
0,85 mm ± 85,2 Ø

Cyl. 1-3
A8 4H2/4H8

796.170
06E 103 149 AR
0,85 mm ± 85,2 Ø

Cyl. 4-6
A8 4H2/4H8

ZKS 223.890
WHT 005 739 (8x)
M 10x1,5x170
2x

461.682
EL-Liq 74
↓

429.910
06E 103 483 Q
Cyl. 4-6

429.980
06E 103 484 P
Cyl. 1-3

CMUA **CTTA**
CTUA **CTUC**
CTUD **CTVA**
CTXA

6 Cyl. **2995 ccm**
Cyl. 84,5 Ø

A4
02/2012 → 12/2015

A5
11/2011 → 01/2017

A6
03/2011 → 09/2018

A7
01/2011 → 03/2015

Q5
06/2012 → 05/2017

ES⊕ **340.590**
CS* **783.930**

323.330
06E 103 148 AG
85,2 Ø

Cyl. 1-3

323.370
06E 103 149 AG
85,2 Ø

Cyl. 4-6

ZKS 223.890
WHT 005 739 (8x)
M 10x1,5x170
2x

461.682
EL-Liq 74
↓

429.910
06E 103 483 Q
Cyl. 4-6

429.980
06E 103 484 P
Cyl. 1-3

CWGD **DCBD**
DCBE

6 Cyl. **2995 ccm**
Cyl. 84,5 Ø

A4 S4
05/2016 → 11/2019

A5 S5
07/2016 →

Q5
11/2016 →

Q7
07/2019 →

Q8
02/2018 →













CS* **519.440**

ZKS 223.890
WHT 005 739 (8x)
M 10x1,5x170
2x

461.682
EL-Liq 74
↓

938.250
06M 103 650 D
Cyl. 1-3

938.240
06M 103 649 D
Cyl. 4-6

			<p>a) </p> <p>b) </p>	<p>K: </p> <p>N: </p>	
<p>VAS 235.650 FPM 724.590 036 109 675 A FPM 24x</p>	<p>724.250 06E 253 039 C 2x </p>	<p>858.060 06E 129 717 F 6x</p>	<p>a) 030.793 Dirko HT</p> <p>b) 858.050 N 911 679 01 incl. 591.840 M 14x1,5x15</p> <p>b) 591.840 N 013 815,8 Metal C 14x20x2</p> <p>b) 813.036 N 013 815,6 CU C 14x20x2</p>	<p>K:← 728.550 06E 103 153 E SP RD PTFE 45x60</p> <p>K:→ 026.790 079 103 051 F ASW LD PTFE/FPM 85x105x8,8</p>	
<p>VAS 235.650 FPM 724.590 036 109 675 A FPM 24x</p>	<p>724.250 06E 253 039 C 2x </p>	<p>225.170 079 129 717 B 6x </p>	<p>a) 030.793 Dirko HT</p> <p>b) 982.340 N 016 027 6 incl. 813.036 M 14x1,5x12</p> <p>b) 591.840 N 013 815,8 Metal C 14x20x2</p> <p>b) 813.036 N 013 815,6 CU C 14x20x2</p>	<p>K:← 728.550 06E 103 153 E SP RD PTFE 45x60</p> <p>K:→ 026.790 079 103 051 F ASW LD PTFE/FPM 85x105x8,8</p>	<p>TLS 796.460</p>
<p>VAS 562.250 FPM A 724.590 036 109 675 A FPM E 12x</p>		<p>928.300 06M 133 198 B 2x </p>	<p>a) 030.793 Dirko HT</p> <p>b) 858.050 N 911 679 01 incl. 591.840 M 14x1,5x15</p> <p>b) 243.205 N 013 849,3 AL A 14x20x1,5</p> <p>b) 591.840 N 013 815,8 Metal C 14x20x2</p>	<p>K:← 263.600 079 103 051 D ASW RD PTFE/ACM 55x70x8</p> <p>K:→ 026.790 079 103 051 F ASW LD PTFE/FPM 85x105x8,8</p>	

AUDI

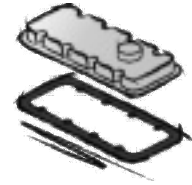
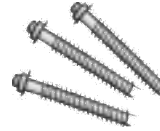

CZSA CZSE
DLZA

6 Cyl. **2995 ccm**
Cyl. 84,5 Ø

A6 02/2018 →
A6 Allroad 11/2019 →
A7 10/2017 →
A8 06/2017 →

ZKS 223.890
WHT 005 739 (8x)
M 10x1,5x170
2x



461.682
EL-Liq 74
↓
938.250
06M 103 650 D
Cyl. 1-3

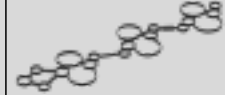

938.240
06M 103 649 D
Cyl. 4-6

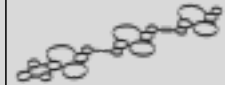

AUK BKH

6 Cyl. **3123 ccm**
Cyl. 84,5 Ø

A4 01/2005 → 03/2009
A6 05/2004 → 05/2009
A6 Allroad 05/2006 → 10/2008

ES⊕ **244.650**
CS* **244.710**

725.160
06E 103 149 M
86 Ø
Cyl. 4-6



725.190
06E 103 148 M
86 Ø
Cyl. 1-3



ZKS 325.040
06E 103 385 E (8x)
M 10x1,5x172
2x



461.682
EL-Liq 74
↓
725.860
06E 103 483 G
Cyl. 4-6



725.870
06E 103 484 G
Cyl. 1-3

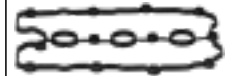











720.220
06E 103 649 E
↓ Cyl. 1-3



720.230
06E 103 650 A
↓ Cyl. 4-6



AUDI

			<p>a) </p> <p>b) </p>	<p>K: </p> <p>N: </p>	
<p>VAS 562.250 FPM A 724.590 036 109 675 A FPM E 12x</p>		<p>928.300 06M 133 198 B 2x</p> 	<p>a) 030.793 Dirko HT</p> <p>b) 858.050 N 911 679 01 incl. 591.840 M 14x1,5x15</p> <p>b) 243.205 N 013 849.3 AL A 14x20x1,5</p> <p>b) 591.840 N 013 815.8 Metal C 14x20x2</p>	<p>K:← 263.600 079 103 051 D ASW RD PTFE/ACM 55x70x8</p> <p>K:→ 026.790 079 103 051 F ASW LD PTFE/FPM 85x105x8,8</p>	
<p>VAS 235.650 FPM 724.590 036 109 675 A FPM 24x</p>	<p>724.250 06E 253 039 C 2x</p> 	<p>232.910 06E 198 717 6x</p> 	<p>a) 030.793 Dirko HT</p> <p>b) 567.640 N 908 132 01 M 14x1,5x22 →4F-6-190 000 →8E-6-285 000</p> <p>b) 982.340 N 016 027 6 incl. 813.036 M 14x1,5x12 4F-6-190 001→ 8E-6-285 001→</p> <p>b) 591.840 N 013 815.8 Metal C 14x20x2 4F-6-190 001→ 8E-6-285 001→</p> <p>b) 813.036 N 013 815.6 CU C 14x20x2 4F-6-190 001→ 8E-6-285 001→</p>	<p>K:← 728.550 06E 103 153 E SP RD PTFE 45x60</p> <p>K:→ 026.790 079 103 051 F ASW LD PTFE/FPM 85x105x8,8</p>	

AUDI

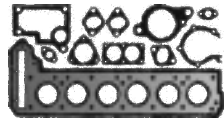

BPK
6 Cyl. **3123 ccm**
Cyl. 84,5 Ø

A8
06/2005 → 07/2010

ES⊕ **244.650**
CS* **244.710**

725.160
06E 103 149 M
86 Ø
Cyl. 4-6



725.190
06E 103 148 M
86 Ø
Cyl. 1-3



ZKS 325.040
06E 103 385 E (8x)
M 10x1,5x172
2x



461.682
EL-Liq 74
↓
725.860
06E 103 483 G
Cyl. 4-6

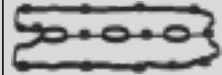

725.870
06E 103 484 G
Cyl. 1-3

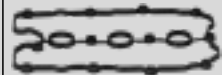

720.220
06E 103 649 E
↓ Cyl. 1-3



720.230
06E 103 650 A
↓ Cyl. 4-6



BYU
6 Cyl. **3123 ccm**
Cyl. 84,5 Ø

A6
09/2006 → 10/2008

ES⊕ **244.650**
CS* **244.710**

725.160
06E 103 149 M
86 Ø
Cyl. 4-6



725.190
06E 103 148 M
86 Ø
Cyl. 1-3



ZKS 325.040
06E 103 385 E (8x)
M 10x1,5x172
2x



461.682
EL-Liq 74
↓
725.860
06E 103 483 G
Cyl. 4-6



725.870
06E 103 484 G
Cyl. 1-3

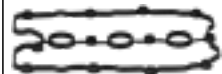



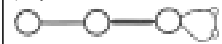









720.220
06E 103 649 E
↓ Cyl. 1-3



720.230
06E 103 650 A
↓ Cyl. 4-6



			<p>a) </p> <p>b) </p>	<p>K: </p> <p>N: </p>	
<p>VAS 235.650 FPM 2x</p> <p>724.590 036 109 675 A FPM 24x</p>	<p>724.250 06E 253 039 C 2x</p> 	<p>232.910 06E 198 717 6x</p> 	<p>a) 030.793 Dirko HT</p> <p>b) 567.640 N 908 132 01 M 14x1,5x22 →4E-6-024 500</p> <p>b) 982.340 N 016 027 6 incl. 813.036 M 14x1,5x12 4E-6-024 501→</p> <p>b) 591.840 N 013 815.8 Metal C 14x20x2 4E-6-024 501→</p> <p>b) 813.036 N 013 815.6 CU C 14x20x2 4E-6-024 501→</p>	<p>K:← 728.550 06E 103 153 E SP RD PTFE 45x60</p> <p>K:→ 026.790 079 103 051 F ASW LD PTFE/FPM 85x105x8,8</p>	
<p>VAS 235.650 FPM</p> <p>724.590 036 109 675 A FPM 24x</p>	<p>724.250 06E 253 039 C 2x</p> 	<p>232.910 06E 198 717 6x</p> 	<p>a) 030.793 Dirko HT</p> <p>b) 982.340 N 016 027 6 incl. 813.036 M 14x1,5x12</p> <p>b) 591.840 N 013 815.8 Metal C 14x20x2</p> <p>b) 813.036 N 013 815.6 CU C 14x20x2</p>	<p>K:← 728.550 06E 103 153 E SP RD PTFE 45x60</p> <p>K:→ 026.790 079 103 051 F ASW LD PTFE/FPM 85x105x8,8</p>	

AUDI

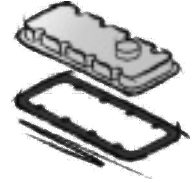
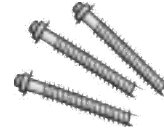
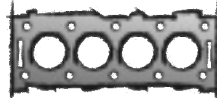
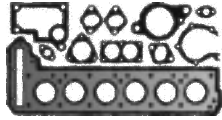

BDB **BHE**
BMJ **BPF**
BUB

6 Cyl. **3189 ccm**
Cyl. 84,0 Ø

A3
07/2003 → 05/2009

TT
07/2003 → 06/2010

ES⊕ **284.540**
CS* **196.200**

807.574
022 103 383 M
0,65 mm $\frac{1}{4}$ 85 Ø

ZKS 332.830
022 103 384 L (13x)
+022 103 384 M (7x)
M 10x1,5x111/141

660.260
022 103 483 E

037.741
022 103 484 F
6x

CBRA

6 Cyl. **3189 ccm**
Cyl. 84,0 Ø

TT
08/2006 → 06/2010

ES⊕ **284.540**
CS* **196.200**

807.574
022 103 383 M
0,65 mm $\frac{1}{4}$ 85 Ø

ZKS 332.830
022 103 384 L (13x)
+022 103 384 M (7x)
M 10x1,5x111/141

660.260
022 103 483 E

037.741
022 103 484 F
6x

CALA
CALB

6 Cyl. **3197 ccm**
Cyl. 85,5 Ø

A4
11/2007 → 03/2012

A5
06/2007 → 03/2012

A6
05/2009 → 03/2011

Q5
11/2008 → 12/2012

ES⊕ **284.300**
CS* **245.690**

717.400
06E 103 148 AC
86,2 Ø
Cyl. 1-3 Cyl. 1-3

717.380
06E 103 149 AC
86,2 Ø
Cyl. 4-6 Cyl. 4-6

















ZKS 325.040
06E 103 385 E (8x)
M 10x1,5x172
→07/2011
2x

ZKS 223.890
WHT 005 739 (8x)
M 10x1,5x170
07/2011→
2x

461.682
EL-Liq 74
↓
429.910
06E 103 483 Q
Cyl. 4-6

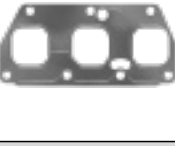
429.980
06E 103 484 P
Cyl. 1-3

AUDI

			<p>a) </p> <p>b) </p>	<p>K: </p> <p>N: </p>	
<p>VAS 235.650 FPM 724.590 036 109 675 A FPM 24x</p>	<p>876.861 022 253 039 E</p>  <p>876.880 022 253 050 C</p> 	<p>728.570 022 133 237 C</p> 	<p>a) 030.793 Dirko HT</p> <p>b) 567.640 N 908 132 01 M 14x1,5x22</p>	<p>K:← 155.560 038 103 085 E ASW RD PTFE/ACM 35x48x10 →8P-5A-087 000 →8P-5B-006 000 →8N-5-012 200</p> <p>K:← 717.450 022 103 151 D SP RD PTFE 35 8N-5-012 201→ 8P-5A-087 001→ 8P-5B-006 001→</p> <p>K:→ 158.430 021 103 051 C ASW LD PTFE 85x105x11</p>	
<p>VAS 235.650 FPM 724.590 036 109 675 A FPM 24x</p>	<p>876.861 022 253 039 E</p>  <p>876.880 022 253 050 C</p> 	<p>728.570 022 133 237 C</p> 	<p>a) 030.793 Dirko HT</p> <p>b) 567.640 N 908 132 01 M 14x1,5x22</p>	<p>K:← 717.450 022 103 151 D SP RD PTFE 35</p> <p>K:→ 158.430 021 103 051 C ASW LD PTFE 85x105x11</p>	
<p>VAS 235.650 FPM 724.590 036 109 675 A FPM 24x</p>	<p>724.250 06E 253 039 C 2x</p> 	<p>232.910 06E 198 717 6x</p> 	<p>a) 030.793 Dirko HT</p> <p>b) 982.340 N 016 027 6 incl. 813.036 M 14x1,5x12</p> <p>b) 591.840 N 013 815.8 Metal C 14x20x2</p> <p>b) 813.036 N 013 815.6 CU C 14x20x2</p>	<p>K:← 728.550 06E 103 153 E SP RD PTFE 45x60</p> <p>K:→ 026.790 079 103 051 F ASW LD PTFE/FPM 85x105x8,8</p>	

AUDI

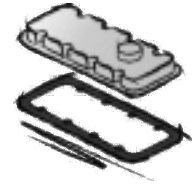

AKF

8 Cyl. **3328 ccm**
Cyl. 78,3 Ø

A8 TDI

06/2000 → 09/2002

471.130

057 103 383 M

0,390 mm
→
0,490 mm

1,10 mm $\frac{\pm}{\pm}$ 79 Ø

L

1 ⊗



471.140

057 103 383 N

0,490 mm
→
0,540 mm

1,15 mm $\frac{\pm}{\pm}$ 79 Ø

L

2 ⊗



471.150

057 103 383 P

0,540 mm
→
0,650 mm

1,20 mm $\frac{\pm}{\pm}$ 79 Ø

L

3 ⊗



471.100

057 103 383 J

0,390 mm
→
0,490 mm

1,10 mm $\frac{\pm}{\pm}$ 79 Ø

R

1 ⊗



471.110

057 103 383 K

0,490 mm
→
0,540 mm

1,15 mm $\frac{\pm}{\pm}$ 79 Ø

R

2 ⊗



471.120

057 103 383 L

0,540 mm
→
0,650 mm

1,20 mm $\frac{\pm}{\pm}$ 79 Ø

R

3 ⊗



ZKS 130.120

057 103 384 A (10x)
M 12x1,5x159
2x



BHK

6 Cyl. **3597 ccm**
Cyl. 89,0 Ø

Q7

08/2006 → 05/2010

ES⊕ **248.260**
→07/2009

ES⊕ **318.730**
07/2009→

CS* **298.400**

151.123

03H 103 383 J

0,95 mm $\frac{\pm}{\pm}$ 90 Ø
→4L-7-148 000

233.220

03H 103 383 K

90 Ø
4L-7-148 001→

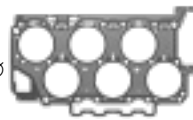

ZKS 713.490









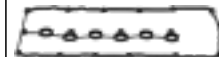





WHT 000 497 A (13x)
+WHT 000 789 A (7x)
M 9x1,5x111/141





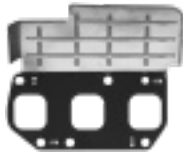





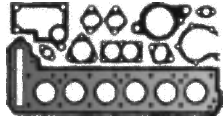
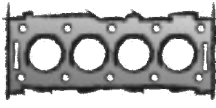

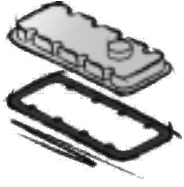



660.270

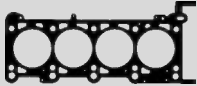
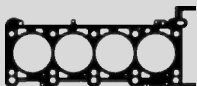





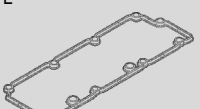
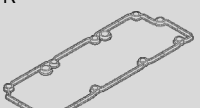





03H 103 483 C

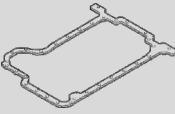

			<p>a) </p> <p>b) </p>	<p>K: </p> <p>N: </p>	
<p>VAS 235.610 FPM 2x</p> <p>724.590 036 109 675 A FPM 32x</p>	<p>231.240 059 253 039 B 8x</p> 	<p>229.302 057 129 717 B 2x</p> 	<p>a) 030.793 Dirko HT</p> <p>b) 878.100 incl. 813.168 028 103 059 A M 24x1,5x10</p> <p>b) 812.773 N 013 850.3 FE C 24x32x2,5</p> <p>b) 813.168 CU C 24x32x2,5</p>	<p>K:← 690.110 077 115 147 A A/BS RD FPM 55x68x8</p>	
<p>VAS 235.650 FPM</p> <p>724.590 036 109 675 A FPM 24x</p>	<p>150.902 03H 253 039 E</p>  <p>150.891 03H 253 050 B</p> 	<p>AAS 311.190 07/2009→</p>  <p>233.250 03H 133 237 B →07/2009</p> 	<p>a) 030.793 Dirko HT</p> <p>b) 567.640 N 908 132 01 M 14x1,5x22</p>	<p>K:← 717.450 022 103 151 D SP RD PTFE 35</p> <p>K:→ 158.430 021 103 051 C ASW LD PTFE 85x105x11</p>	

<p>AUDI</p> 				
<p>AEW AKJ</p> <p>8 Cyl. 3697 ccm Cyl. 84,5 Ø</p> <p>A8 07/1995 → 12/1998</p>		<p>156.870 077 103 383 AD 1,75 mm $\frac{+}{-}$ 85,3 Ø L</p>  <p>156.830 077 103 383 AC 1,75 mm $\frac{+}{-}$ 85,3 Ø R</p> 	<p>ZKS 267.460 077 103 385 (10x) M 11x1,5x154 2x</p> 	
<p>AKC AQG BFL</p> <p>8 Cyl. 3697 ccm Cyl. 84,5 Ø</p> <p>A6 03/1999 → 01/2005</p> <p>A8 11/1998 → 05/2006</p>			<p>ZKS 215.000 077 103 385 D (10x) M 10x1,5x115 2x</p> 	<p>ZKHS 255.570 077 198 025 A 2x</p> 
<p>ASE</p> <p>8 Cyl. 3936 ccm Cyl. 81,0 Ø</p> <p>A8 TDI 05/2003 → 07/2005</p>		<p>877.372 057 103 383 CC 1,10 mm $\frac{+}{-}$ L 1 ⊗</p>  <p>877.422 057 103 383 CD 1,15 mm $\frac{+}{-}$ L 2 ⊗</p>  <p>877.452 ● 057 103 383 CE 1,20 mm $\frac{+}{-}$ L 3 ⊗</p>  <p>877.311 057 103 383 BQ 1,10 mm $\frac{+}{-}$ R 1 ⊗</p>  <p>877.351 ● 057 103 383 BR 1,15 mm $\frac{+}{-}$ R 2 ⊗</p>  <p>877.361 057 103 383 BS 1,20 mm $\frac{+}{-}$ R 3 ⊗</p> 	<p>ZKS 130.120 057 103 384 A (10x) M 12x1,5x159 2x</p> 	<p>215.580 ● 057 103 483 G L</p>  <p>215.570 ● 057 103 483 H R</p> 

AUDI

			<p>a) </p> <p>b) </p>	<p>K: </p> <p>N: </p>	
<p>VAS 235.610 FPM 2x</p> <p>724.590 036 109 675 A FPM 32x</p>			<p>a) 632.510 077 103 609 E ↑ </p> <p>b) 878.100 incl. 813.168 028 103 059 A M 24x1,5x10</p> <p>b) 812.773 N 013 850.3 FE C 24x32x2,5</p> <p>b) 813.168 CU C 24x32x2,5</p>	<p>K:← 294.357 069 115 147 E ASW RD FPM/ACM 35x48x10</p> <p>K:← 475.961 054 115 147 B ASW RD FPM 35x48x10</p> <p>N:← 325.155 068 103 085 E ASW WD FPM/ACM 32x47x10 2x</p>	
<p>VAS 235.620 FPM 2x</p> <p>724.590 036 109 675 A FPM 40x</p>	<p>530.930 077 253 039 C 2x </p>	<p>530.982 077 129 717 Q 2x </p>	<p>a) 030.793 Dirko HT</p> <p>b) 878.100 incl. 813.168 028 103 059 A M 24x1,5x10</p> <p>b) 812.773 N 013 850.3 FE C 24x32x2,5</p> <p>b) 813.168 CU C 24x32x2,5</p>	<p>K:← 690.110 077 115 147 A A/BS RD FPM 55x68x8</p> <p>N:← 325.155 068 103 085 E ASW WD FPM/ACM 32x47x10 4x</p>	
<p>VAS 235.610 FPM 2x</p> <p>724.590 036 109 675 A FPM 32x</p>	<p>231.240 059 253 039 B 8x </p>		<p>a) 030.793 Dirko HT</p> <p>b) 878.100 incl. 813.168 028 103 059 A M 24x1,5x10</p> <p>b) 812.773 N 013 850.3 FE C 24x32x2,5</p> <p>b) 813.168 CU C 24x32x2,5</p>	<p>K:← 690.110 077 115 147 A A/BS RD FPM 55x68x8</p> <p>K:→ 026.790 079 103 051 F ASW LD PTFE/FPM 85x105x8,8</p> <p>N:→ 326.470 028 103 086 A ASW LD PTFE/ACM 32x47x10</p> <p>N:→ 798.040 028 103 086 C ASW OF LD FPM 32x47x10</p>	

AUDI

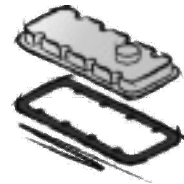
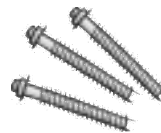
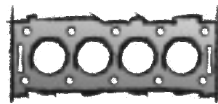
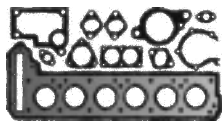

CVXB

8 Cyl. 3956 ccm
Cyl. 83,0 Ø

A8 TDI

11/2019 →

309.361

057 103 383 MH

 0,810 mm

→

0,910 mm

1,60 mm $\frac{+}{-}$ 84,3 Ø

L

1 ⊗

309.371

057 103 383 MJ

 0,910 mm

→

0,960 mm

1,65 mm $\frac{+}{-}$ 84,3 Ø

L

2 ⊗

309.381

057 103 383 MK

 0,960 mm

→

1,070 mm

1,70 mm $\frac{+}{-}$ 84,3 Ø

L

3 ⊗



309.340

057 103 383 KQ

 0,910 mm

→

0,960 mm

1,65 mm $\frac{+}{-}$ 84,3 Ø

R

2 ⊗

309.350

057 103 383 KR

 0,960 mm

→

1,070 mm

1,70 mm $\frac{+}{-}$ 84,3 Ø

R

3 ⊗



309.330

057 103 383 KP

 0,810 mm

→









0,910 mm

1,60 mm $\frac{+}{-}$ 84,3 Ø

R Cyl. 1-4

1 ⊗



			<p>a) </p> <p>b) </p>	<p>K: </p> <p>N: </p>	
<p>VAS 235.610 FPM E</p> <p>724.590 036 109 675 A FPM E 16x</p> <p>797.560 06L 09 675 C FPM A 16x</p>	<p>311.022 057 253 039 AA 2x</p>		<p>a) 030.793 Dirko HT</p> <p>b) 591.840 N 013 815.8 Metal C 14x20x2</p> <p>b) 813.036 N 013 815.6 CU C 14x20x2</p>	<p>K:← 263.600 079 103 051 D ASW RD PTFE/ACM 55x70x8</p> <p>K:→ 331.330 059 103 051 K ASW OF LD FPM 85x105x8</p>	

AUDI

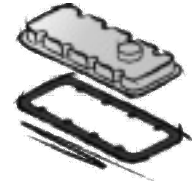
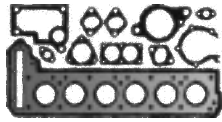

CZAA CZAC
DMVA

8 Cyl. **3956 ccm**
Cyl. 83,0 Ø

Q7 TDI
04/2016 →

309.361
057 103 383 MH
 0,810 mm
→
0,910 mm
1,60 mm $\frac{+}{-}$ 84,3 Ø
L
1 ⊗

309.371
057 103 383 MJ
 0,910 mm
→
0,960 mm
1,65 mm $\frac{+}{-}$ 84,3 Ø
L
2 ⊗

309.381
057 103 383 MK
 0,960 mm
→
1,070 mm
1,70 mm $\frac{+}{-}$ 84,3 Ø
L
3 ⊗



309.340
057 103 383 KQ
 0,910 mm
→
0,960 mm
1,65 mm $\frac{+}{-}$ 84,3 Ø
R
2 ⊗

309.350
057 103 383 KR
 0,960 mm
→
1,070 mm
1,70 mm $\frac{+}{-}$ 84,3 Ø
R
3 ⊗



309.330
057 103 383 KP
 0,810 mm
→
0,910 mm
1,60 mm $\frac{+}{-}$ 84,3 Ø
R Cyl. 1-4
1 ⊗



599.600
057 103 483 P
L

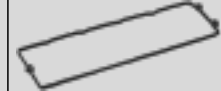

599.590
057 103 484 D
R



323.480
059 103 085 L
8x



CEUA CEUC
CGTA

8 Cyl. **3993 ccm**
Cyl. 84,5 Ø

A6 S6
02/2012 → 09/2018
A7 S7
02/2012 → 03/2015
A8
03/2012 → 12/2014
A8 S8
04/2012 → 01/2018

ES⊕ **780.660**
CS* **441.310**

240.170
079 103 383 DQ
0,90 mm $\frac{+}{-}$ 85,5 Ø
L

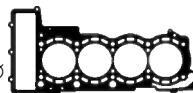

240.160
079 103 383 DP
0,90 mm $\frac{+}{-}$ 85,5 Ø
R























036.164
D 000 400
Dirko HT / EU

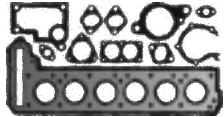
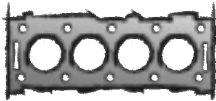

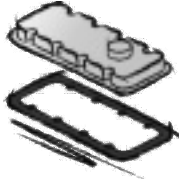



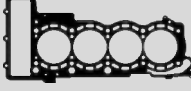

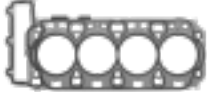
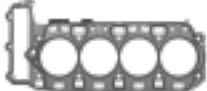











510.031
D 000 400
Dirko HT / USA/CDN/MEX

527.291
D 000 400
Dirko HT / RU

648.661
D 000 400
Dirko HT / BR

			<p>a) </p> <p>b) </p>	<p>K: </p> <p>N: </p>	
<p>VAS 235.610 FPM E</p> <p>724.590 036 109 675 A FPM E 16x</p> <p>797.560 06L 09 675 C FPM A 16x</p>	<p>311.022 057 253 039 AA 2x</p>		<p>a) 030.793 Dirko HT</p> <p>b) 858.050 N 911 679 01 incl. 591.840 M 14x1,5x15</p> <p>b) 591.840 N 013 815.8 Metal C 14x20x2</p> <p>b) 813.036 N 013 815.6 CU C 14x20x2</p>	<p>K:← 263.600 079 103 051 D ASW RD PTFE/ACM 55x70x8</p> <p>K:→ 331.330 059 103 051 K ASW OF LD FPM 85x105x8</p>	
<p>VAS 235.610 FPM 2x</p> <p>724.590 036 109 675 A FPM 32x</p>	<p>717.930 079 253 039 M 2x</p> 	<p>696.180 079 129 717 G L 4x</p>  <p>696.200 079 129 717 H R 4x</p> 	<p>a) 030.793 Dirko HT</p> <p>b) 982.340 N 016 027 6 incl. 813.036 M 14x1,5x12</p> <p>b) 591.840 N 013 815.8 Metal C 14x20x2</p> <p>b) 813.036 N 013 815.6 CU C 14x20x2</p>	<p>K:← 173.890 079 103 051 G ASW RD PTFE/ACM 55x72x8</p> <p>K:→ 026.790 079 103 051 F ASW LD PTFE/FPM 85x105x8,8</p>	<p>TLS 798.530</p> 

<p>AUDI</p> 				
<p>CTGA CTGE CTGF</p> <p>8 Cyl. 3993 ccm Cyl. 84,5 Ø</p> <p>A6 S6 10/2014 → 09/2018</p> <p>A7 S7 07/2014 → 05/2018</p> <p>A8 10/2013 → 01/2018</p>	<p>ES⊕ 780.660 CS* 441.310</p>	<p>240.170 079 103 383 DQ 0,90 mm $\frac{\pm}{\pm}$ 85,5 Ø L</p>  <p>240.160 079 103 383 DP 0,90 mm $\frac{\pm}{\pm}$ 85,5 Ø R</p> 		<p>036.164 D 000 400 Dirko HT / EU</p> <p>510.031 D 000 400 Dirko HT / USA/CDN/MEX</p> <p>527.291 D 000 400 Dirko HT / RU</p> <p>648.661 D 000 400 Dirko HT / BR</p>
<p>CRDB CWUB CWUC</p> <p>8 Cyl. 3993 ccm Cyl. 84,5 Ø</p> <p>A6 RS6 01/2013 → 09/2018</p> <p>A7 RS7 10/2013 → 04/2018</p>	<p>ES⊕ 780.660</p>	<p>240.170 079 103 383 DQ 0,90 mm $\frac{\pm}{\pm}$ 85,5 Ø L</p>  <p>240.160 079 103 383 DP 0,90 mm $\frac{\pm}{\pm}$ 85,5 Ø R</p> 		<p>036.164 D 000 400 Dirko HT / EU</p> <p>510.031 D 000 400 Dirko HT / USA/CDN/MEX</p> <p>527.291 D 000 400 Dirko HT / RU</p> <p>648.661 D 000 400 Dirko HT / BR</p>
<p>CTFA DDTA</p> <p>8 Cyl. 3993 ccm Cyl. 84,5 Ø</p> <p>A8 S8 04/2012 → 01/2018</p>	<p>ES⊕ 780.660 CS* 441.310</p>	<p>240.170 079 103 383 DQ 0,90 mm $\frac{\pm}{\pm}$ 85,5 Ø L</p>  <p>240.160 079 103 383 DP 0,90 mm $\frac{\pm}{\pm}$ 85,5 Ø R</p> 		<p>036.164 D 000 400 Dirko HT / EU</p> <p>510.031 D 000 400 Dirko HT / USA/CDN/MEX</p> <p>527.291 D 000 400 Dirko HT / RU</p> <p>648.661 D 000 400 Dirko HT / BR</p>
<p>CWWB DCUE DJPB CXYA DHUB</p> <p>8 Cyl. 3996 ccm Cyl. 86,0 Ø</p> <p>A6 RS6 09/2019 →</p> <p>A7 RS7 10/2019 →</p> <p>A8 05/2018 →</p> <p>A8 S8 02/2019 →</p> <p>Q7 02/2020 →</p> <p>Q8 09/2019 →</p>		<p>390.811 0P2 103 383 G 0,90 mm $\frac{\pm}{\pm}$ 87 Ø L</p>  <p>390.801 0P2 103 383 F 0,90 mm $\frac{\pm}{\pm}$ 87 Ø R</p> 		

			<p>a) </p> <p>b) </p>	<p>K: </p> <p>N: </p>	
<p>VAS 235.610 FPM 2x</p> <p>724.590 036 109 675 A FPM 32x</p>	<p>717.930 079 253 039 M 2x</p> 	<p>696.180 079 129 717 G L 4x</p>  <p>696.200 079 129 717 H R 4x</p> 	<p>a) 030.793 Dirko HT</p> <p>b) 858.050 N 911 679 01 incl. 591.840 M 14x1,5x15</p> <p>b) 591.840 N 013 815.8 Metal C 14x20x2</p> <p>b) 813.036 N 013 815.6 CU C 14x20x2</p>	<p>K:← 173.890 079 103 051 G ASW RD PTFE/ACM 55x72x8</p> <p>K:→ 026.790 079 103 051 F ASW LD PTFE/FPM 85x105x8,8</p>	<p>TLS 798.530</p> 
<p>VAS 235.610 FPM 2x</p> <p>724.590 036 109 675 A FPM 32x</p>	<p>717.930 079 253 039 M 2x</p> 	<p>696.180 079 129 717 G L 4x</p>  <p>696.200 079 129 717 H R 4x</p> 	<p>a) 030.793 Dirko HT</p> <p>b) 858.050 N 911 679 01 incl. 591.840 M 14x1,5x15</p> <p>b) 591.840 N 013 815.8 Metal C 14x20x2</p> <p>b) 813.036 N 013 815.6 CU C 14x20x2</p>	<p>K:← 263.600 079 103 051 D ASW RD PTFE/ACM 55x70x8</p> <p>K:→ 026.790 079 103 051 F ASW LD PTFE/FPM 85x105x8,8</p>	<p>TLS 798.530</p> 
<p>VAS 235.610 FPM 2x</p> <p>724.590 036 109 675 A FPM 32x</p>	<p>717.930 079 253 039 M 2x</p> 	<p>696.180 079 129 717 G L 4x</p>  <p>696.200 079 129 717 H R 4x</p> 	<p>a) 030.793 Dirko HT</p> <p>b) 591.840 N 013 815.8 Metal C 14x20x2</p> <p>b) 813.036 N 013 815.6 CU C 14x20x2</p>	<p>K:← 173.890 079 103 051 G ASW RD PTFE/ACM 55x72x8</p> <p>K:→ 026.790 079 103 051 F ASW LD PTFE/FPM 85x105x8,8</p>	<p>TLS 798.530</p> 
<p>VAS 235.610 FPM 2x</p> <p>724.590 036 109 675 A FPM 32x</p>	<p>842.660 0P2 253 039 C 2x</p>		<p>a) 030.793 Dirko HT</p> <p>b) 243.205 N 013 849.3 AL A 14x20x1,5</p>	<p>K:← 263.600 079 103 051 D ASW RD PTFE/ACM 55x70x8</p> <p>K:→ 026.790 079 103 051 F ASW LD PTFE/FPM 85x105x8,8</p>	

AUDI



BMC BVN
8 Cyl. 4134 ccm
Cyl. 83,0 Ø

A8 TDI
01/2005 → 07/2010

ES⊕ 566.820



149.332
057 103 383 EQ
1,10 mm $\frac{+}{-}$ 83,8 Ø
L
1 ⊗

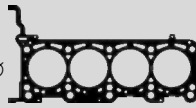

149.342
057 103 383 ER
1,15 mm $\frac{+}{-}$ 83,8 Ø
L
2 ⊗



149.354
057 103 383 ES
1,20 mm $\frac{+}{-}$ 83,8 Ø
L
3 ⊗

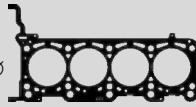

149.302
057 103 383 EM
1,10 mm $\frac{+}{-}$ 83,8 Ø
R
1 ⊗

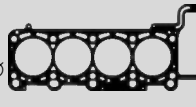

149.312
057 103 383 EN
1,15 mm $\frac{+}{-}$ 83,8 Ø
R
2 ⊗

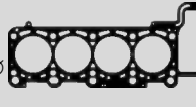

149.324
057 103 383 EP
1,20 mm $\frac{+}{-}$ 83,8 Ø
R
3 ⊗

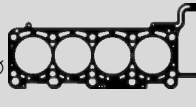

ZKS 130.120
057 103 384 A (10x)
M 12x1,5x159
2x



482.350
057 103 483 J
L

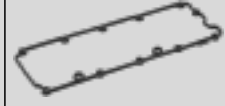

482.340
057 103 484
R

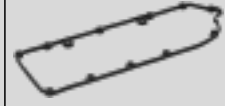

BTR
8 Cyl. 4134 ccm
Cyl. 83,0 Ø

Q7 TDI
03/2007 → 06/2009

ES⊕ 566.820



149.332
057 103 383 EQ
1,10 mm $\frac{+}{-}$ 83,8 Ø
L
1 ⊗

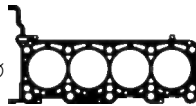

149.342
057 103 383 ER
1,15 mm $\frac{+}{-}$ 83,8 Ø
L
2 ⊗

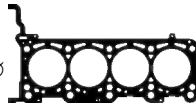

149.354
057 103 383 ES
1,20 mm $\frac{+}{-}$ 83,8 Ø
L
3 ⊗

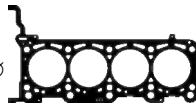

149.302
057 103 383 EM
1,10 mm $\frac{+}{-}$ 83,8 Ø
R
1 ⊗

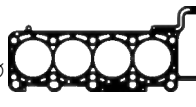

149.312
057 103 383 EN
1,15 mm $\frac{+}{-}$ 83,8 Ø
R
2 ⊗



149.324
057 103 383 EP
1,20 mm $\frac{+}{-}$ 83,8 Ø
R
3 ⊗



ZKS 130.120
057 103 384 A (10x)
M 12x1,5x159
2x



















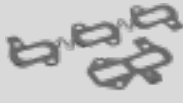





482.350
057 103 483 J
L

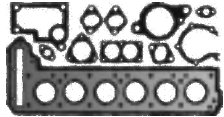
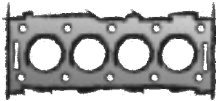

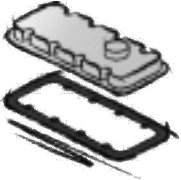

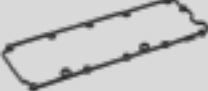
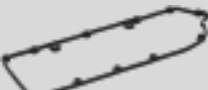



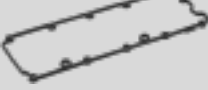
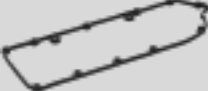













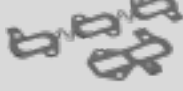



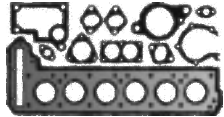
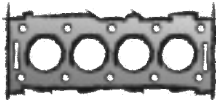

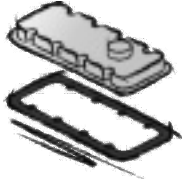

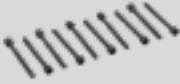

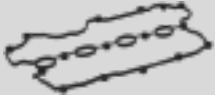

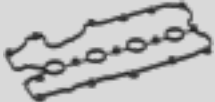
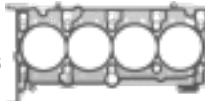

482.340
057 103 484
R

















			<p>a) </p> <p>b) </p>	<p>K: </p> <p>N: </p>	
<p>VAS 235.610 FPM 2x</p> <p>724.590 036 109 675 A FPM 32x</p>	<p>AAS 196.600 059 253 039 E 2x</p>  <p>148.271 059 253 039 E 2x</p>  <p>149.080 057 253 039 D 2x</p>	<p>482.230 057 129 717 G 2x</p> 	<p>a) 030.793 Dirko HT</p> <p>b) 878.100 incl. 813.168 028 103 059 A M 24x1,5x10</p> <p>b) 812.773 N 013 850.3 FE C 24x32x2,5</p> <p>b) 813.168 CU C 24x32x2,5</p>	<p>K:← 263.600 079 103 051 D ASW RD PTFE/ACM 55x70x8</p> <p>K:→ 026.790 079 103 051 F ASW LD PTFE/FPM 85x105x8,8</p> <p>N:→ 326.470 028 103 086 A ASW LD PTFE/ACM 32x47x10</p> <p>N:→ 798.040 028 103 086 C ASW OF LD FPM 32x47x10</p>	
<p>VAS 235.610 FPM 2x</p> <p>724.590 036 109 675 A FPM 32x</p>	<p>AAS 196.600 059 253 039 E 2x</p>  <p>148.271 059 253 039 E 2x</p>  <p>149.080 057 253 039 D 2x</p>	<p>482.230 057 129 717 G 2x</p> 	<p>a) 030.793 Dirko HT</p> <p>b) 982.340 N 016 027 6 incl. 813.036 M 14x1,5x12</p> <p>b) 591.840 N 013 815.8 Metal C 14x20x2</p> <p>b) 813.036 N 013 815.6 CU C 14x20x2</p>	<p>K:← 263.600 079 103 051 D ASW RD PTFE/ACM 55x70x8</p> <p>K:→ 026.790 079 103 051 F ASW LD PTFE/FPM 85x105x8,8</p> <p>N:→ 326.470 028 103 086 A ASW LD PTFE/ACM 32x47x10</p> <p>N:→ 798.040 028 103 086 C ASW OF LD FPM 32x47x10</p>	

<p>AUDI</p> 				
<p>CCFA CCFC</p> <p>8 Cyl. 4134 ccm Cyl. 83,0 Ø</p> <p>Q7 TDI 03/2007 → 08/2015</p>			<p>ZKS 130.120 057 103 384 A (10x) M 12x1,5x159 2x</p> 	<p>482.350 057 103 483 J L</p>  <p>482.340 057 103 484 R</p> 
<p>CDSB</p> <p>8 Cyl. 4134 ccm Cyl. 83,0 Ø</p> <p>A8 TDI 11/2009 → 04/2014</p>			<p>ZKS 130.120 057 103 384 A (10x) M 12x1,5x159 2x</p> 	<p>482.350 057 103 483 J L</p>  <p>482.340 057 103 484 R</p> 
<p>CTEC</p> <p>8 Cyl. 4134 ccm Cyl. 83,0 Ø</p> <p>A8 TDI 10/2013 → 01/2018</p>			<p>ZKS 130.120 057 103 384 A (10x) M 12x1,5x159 2x</p> 	<p>482.350 057 103 483 J L</p>  <p>482.340 057 103 484 R</p> 

			<p>a) </p> <p>b) </p>	<p>K: </p> <p>N: </p>	
<p>VAS 235.610 FPM 2x</p> <p>724.590 036 109 675 A FPM 32x</p>	<p>574.651 057 253 039 M 2x</p>  <p>574.660 059 253 039 L 2x</p> 	<p>482.230 057 129 717 G 2x</p> 	<p>a) 030.793 Dirko HT</p> <p>b) 982.340 N 016 027 6 incl. 813.036 M 14x1,5x12</p> <p>b) 591.840 N 013 815.8 Metal C 14x20x2</p> <p>b) 813.036 N 013 815.6 CU C 14x20x2</p>	<p>K:→ 331.330 059 103 051 K ASW OF LD FPM 85x105x8</p> <p>N:→ 326.470 028 103 086 A ASW LD PTFE/ACM 32x47x10</p> <p>N:→ 798.040 028 103 086 C ASW OF LD FPM 32x47x10</p>	
<p>VAS 235.610 FPM 2x</p> <p>724.590 036 109 675 A FPM 32x</p>	<p>AAS 196.600 059 253 039 E 2x</p> 	<p>482.230 057 129 717 G 2x</p> 	<p>a) 030.793 Dirko HT</p> <p>b) 982.340 N 016 027 6 incl. 813.036 M 14x1,5x12</p> <p>b) 591.840 N 013 815.8 Metal C 14x20x2</p> <p>b) 813.036 N 013 815.6 CU C 14x20x2</p>	<p>K:→ 331.330 059 103 051 K ASW OF LD FPM 85x105x8</p> <p>N:→ 326.470 028 103 086 A ASW LD PTFE/ACM 32x47x10</p> <p>N:→ 798.040 028 103 086 C ASW OF LD FPM 32x47x10</p>	
<p>VAS 235.610 FPM 2x</p> <p>724.590 036 109 675 A FPM 32x</p>	<p>AAS 196.600 059 253 039 E 2x</p> 	<p>482.230 057 129 717 G 2x</p> 	<p>a) 030.793 Dirko HT</p> <p>b) 982.340 N 016 027 6 incl. 813.036 M 14x1,5x12</p> <p>b) 591.840 N 013 815.8 Metal C 14x20x2</p> <p>b) 813.036 N 013 815.6 CU C 14x20x2</p>	<p>N:→ 326.470 028 103 086 A ASW LD PTFE/ACM 32x47x10</p> <p>N:→ 798.040 028 103 086 C ASW OF LD FPM 32x47x10</p>	

<p>AUDI</p> 				
<p>BAR</p> <p>8 Cyl. 4163 ccm Cyl. 84,5 Ø</p> <p>Q7 03/2006 → 12/2010</p>	<p>ES⊕ 520.720 →4L-9-029 260</p> <p>ES⊕ 520.780 4L-9-029 261→</p>	<p>174.030 079 103 383 AR L</p>  <p>174.020 079 103 383 AQ R</p> 	<p>ZKS 341.400 WHT 001 017 (8x) M10x1,5x113 2x</p> 	<p>473.670 079 103 650 C L</p>  <p>898.610 079 103 483 T L 4L-8-022 001→</p>  <p>473.660 079 103 649 C R</p>  <p>898.620 079 103 484 C R</p> 
<p>BAS</p> <p>8 Cyl. 4163 ccm Cyl. 84,5 Ø</p> <p>Allroad 07/2002 → 08/2005</p>		<p>278.940 079 103 383 BB L 86 Ø</p>  <p>278.930 079 103 383 BA R 86 Ø</p> 	<p>ZKS 215.000 077 103 385 D (10x) M 10x1,5x115 2x</p> 	<p>ZKHS 051.980 L</p>  <p>ZKHS 052.120 R</p> 
<p>BAT BNK</p> <p>8 Cyl. 4163 ccm Cyl. 84,5 Ø</p> <p>A6 05/2004 → 05/2006</p>		<p>278.940 079 103 383 BB L 86 Ø</p>  <p>278.930 079 103 383 BA R 86 Ø</p> 	<p>ZKS 215.000 077 103 385 D (10x) M 10x1,5x115 2x</p> 	<p>ZKHS 051.980 L →05/2005</p>  <p>ZKHS 052.120 R →05/2005</p>  <p>473.670 079 103 650 C L 05/2005→</p>  <p>473.660 079 103 649 C R 05/2005→</p> 

			<p>a) </p> <p>b) </p>	<p>K: </p> <p>N: </p>	
<p>VAS 235.610 FPM 2x 724.590 036 109 675 A FPM 32x</p>	<p>130.130 079 253 039 F 2x </p>	<p>473.650 079 133 074 B →4L-9-029 260 2x </p> <p>225.170 079 129 717 B 4L-9-029 261→ 8x </p>	<p>a) 030.793 Dirko HT</p> <p>b) 982.340 N 016 027 6 incl. 813.036 M 14x1,5x12</p> <p>b) 591.840 N 013 815.8 Metal C 14x20x2</p> <p>b) 813.036 N 013 815.6 CU C 14x20x2</p>	<p>K:← 173.890 079 103 051 G ASW RD PTFE/ACM 55x72x8</p> <p>K:→ 026.790 079 103 051 F ASW LD PTFE/FPM 85x105x8,8</p>	
<p>VAS 235.620 FPM 2x 724.590 036 109 675 A FPM 40x</p>	<p>530.930 077 253 039 C 2x </p>	<p>530.982 077 129 717 Q 2x </p>	<p>a) 030.793 Dirko HT</p> <p>b) 878.100 incl. 813.168 028 103 059 A M 24x1,5x10</p> <p>b) 812.773 N 013 850.3 FE C 24x32x2,5</p> <p>b) 813.168 CU C 24x32x2,5</p>	<p>K:← 173.890 079 103 051 G ASW RD PTFE/ACM 55x72x8</p> <p>K:→ 026.790 079 103 051 F ASW LD PTFE/FPM 85x105x8,8</p>	
<p>VAS 235.620 FPM 2x 724.590 036 109 675 A FPM 40x</p>	<p>530.930 077 253 039 C 2x </p>	<p>530.982 077 129 717 Q 2x </p>	<p>a) 030.793 Dirko HT</p> <p>b) 878.100 incl. 813.168 028 103 059 A M 24x1,5x10</p> <p>b) 812.773 N 013 850.3 FE C 24x32x2,5</p> <p>b) 813.168 CU C 24x32x2,5</p>	<p>K:← 173.890 079 103 051 G ASW RD PTFE/ACM 55x72x8</p> <p>K:→ 026.790 079 103 051 F ASW LD PTFE/FPM 85x105x8,8</p>	

AUDI

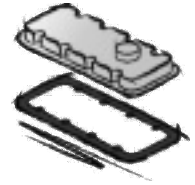

BBK
8 Cyl. **4163 ccm**
Cyl. 84,5 Ø

A4 S4
03/2003 → 03/2009

278.940
079 103 383 BB
L
86 Ø

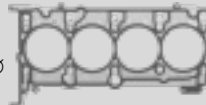

278.930
079 103 383 BA
R
86 Ø



ZKS 215.000
077 103 385 D (10x)
M 10x1,5x115
2x



ZKHS 051.980
L
→8E-5-400 000



ZKHS 052.120
R
→8E-5-400 000



473.670
079 103 650 C
L
8E-5-400 001→



473.660
079 103 649 C
R
8E-5-400 001→



BHF
8 Cyl. **4163 ccm**
Cyl. 84,5 Ø

A4 S4
03/2003 → 03/2009

278.940
079 103 383 BB
L
86 Ø

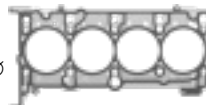

278.930
079 103 383 BA
R
86 Ø



ZKS 215.000
077 103 385 D (10x)
M 10x1,5x115
2x



473.670
079 103 650 C
L



473.660
079 103 649 C
R



BNS
8 Cyl. **4163 ccm**
Cyl. 84,5 Ø

A4 RS4
09/2005 → 12/2008

174.030
079 103 383 AR
L



174.020
079 103 383 AQ
R



ZKS 341.400
WHT 001 017 (8x)
M10x1,5x113
2x



473.670
079 103 650 C
L



898.610
079 103 483 T
L
8E-8-901 901→
8H-8-800 540→









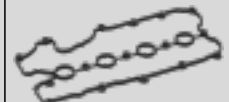







473.660
079 103 649 C
R



898.620
079 103 484 C
R



			<p>a) </p> <p>b) </p>	<p>K: </p> <p>N: </p>	
<p>VAS 235.620 FPM 2x 724.590 036 109 675 A FPM 40x</p>	<p>530.930 077 253 039 C 2x </p>	<p>530.982 077 129 717 Q 2x </p>	<p>a) 030.793 Dirko HT</p> <p>b) 878.100 incl. 813.168 028 103 059 A M 24x1,5x10</p> <p>b) 812.773 N 013 850.3 FE C 24x32x2,5</p> <p>b) 813.168 CU C 24x32x2,5</p>	<p>K:← 173.890 079 103 051 G ASW RD PTFE/ACM 55x72x8</p> <p>K:→ 026.790 079 103 051 F ASW LD PTFE/FPM 85x105x8,8</p>	
<p>VAS 235.620 FPM 2x 724.590 036 109 675 A FPM 40x</p>	<p>530.930 077 253 039 C 2x </p>	<p>530.982 077 129 717 Q 2x </p>	<p>a) 030.793 Dirko HT</p> <p>b) 878.100 incl. 813.168 028 103 059 A M 24x1,5x10</p> <p>b) 812.773 N 013 850.3 FE C 24x32x2,5</p> <p>b) 813.168 CU C 24x32x2,5</p>	<p>K:← 173.890 079 103 051 G ASW RD PTFE/ACM 55x72x8</p> <p>K:→ 026.790 079 103 051 F ASW LD PTFE/FPM 85x105x8,8</p>	
<p>VAS 235.610 FPM 2x 724.590 036 109 675 A FPM 32x</p>	<p>130.130 079 253 039 F 2x </p>	<p>473.650 079 133 074 B 2x </p>	<p>a) 030.793 Dirko HT</p> <p>b) 982.340 N 016 027 6 incl. 813.036 M 14x1,5x12</p> <p>b) 591.840 N 013 815.8 Metal C 14x20x2</p> <p>b) 813.036 N 013 815.6 CU C 14x20x2</p>	<p>K:← 173.890 079 103 051 G ASW RD PTFE/ACM 55x72x8</p> <p>K:→ 026.790 079 103 051 F ASW LD PTFE/FPM 85x105x8,8</p>	

AUDI

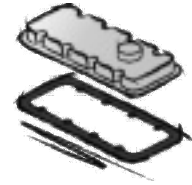
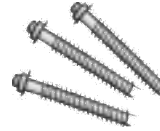

BVJ
8 Cyl. **4163 ccm**
Cyl. 84,5 Ø

A6
06/2006 → 08/2011

A6 Allroad
05/2006 → 12/2010

A8
06/2006 → 07/2010

ES⊕ **520.720**
A6 4F2/4F5
→07/2008

A8 4E2/4E8
→11/2008

ES⊕ **520.780**
A6 4F2/4F5
07/2008→

A8 4E2/4E8
11/2008→

174.030
079 103 383 AR
L

174.020
079 103 383 AQ
R

ZKS 341.400
WHT 001 017 (8x)
M10x1,5x113
2x

473.670
079 103 650 C
L

898.610
079 103 483 T
L
A6 4F2/4F5
4F-8-045 001→

A8 4E2/4E8

473.660
079 103 649 C
R

898.620
079 103 484 C
R

BYH
8 Cyl. **4163 ccm**
Cyl. 84,5 Ø

R8
04/2007 → 09/2010

174.030
079 103 383 AR
L

174.020
079 103 383 AQ
R

ZKS 341.400
WHT 001 017 (8x)
M10x1,5x113
2x













473.670
079 103 650 C
L

898.610
079 103 483 T
L
11/2007→

473.660
079 103 649 C
R

898.620
079 103 484 C
R

AUDI

			<p>a) </p> <p>b) </p>	<p>K: </p> <p>N: </p>	
<p>VAS 235.610 FPM 2x</p> <p>724.590 036 109 675 A FPM 32x</p>	<p>130.130 079 253 039 F 2x</p> 	<p>473.650 079 133 074 B 2x</p> <hr/> <p>A6 4F2/4F5 →07/2008</p> <hr/> <p>A8 4E2/4E8 →11/2008</p>  <hr/> <p>225.170 079 129 717 B 8x</p> <hr/> <p>A6 4F2/4F5 07/2008→</p> <hr/> <p>A8 4E2/4E8 11/2008→</p> 	<p>a) 030.793 Dirko HT</p> <p>b) 982.340 N 016 027 6 incl. 813.036 M 14x1,5x12</p> <p>b) 591.840 N 013 815.8 Metal C 14x20x2</p> <p>b) 813.036 N 013 815.6 CU C 14x20x2</p>	<p>K:← 173.890 079 103 051 G ASW RD PTFE/ACM 55x72x8</p> <p>K:→ 026.790 079 103 051 F ASW LD PTFE/FPM 85x105x8,8</p>	
<p>VAS 235.610 FPM 2x</p> <p>724.590 036 109 675 A FPM 32x</p>	<p>130.130 079 253 039 F 2x</p> 	<p>473.650 079 133 074 B 2x</p> 	<p>a) 030.793 Dirko HT</p> <p>b) 110.353 N 013 812.8 CU A 12x15,5x1,5</p>	<p>K:← 173.890 079 103 051 G ASW RD PTFE/ACM 55x72x8</p> <p>K:→ 026.790 079 103 051 F ASW LD PTFE/FPM 85x105x8,8</p>	

AUDI

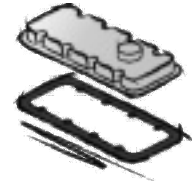
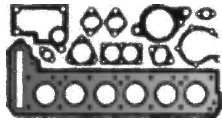

CAUA
8 Cyl. **4163 ccm**
Cyl. 84,5 Ø

A5 S5
06/2007 → 03/2012

ES⊕ **520.720**
→11/2008

ES⊕ **520.780**
11/2008→

174.030
079 103 383 AR
L



174.020
079 103 383 AQ
R



ZKS 341.400
WHT 001 017 (8x)
M10x1,5x113
2x



473.670
079 103 650 C
L



898.610
079 103 483 T
L
10/2007→



473.660
079 103 649 C
R



898.620
079 103 484 C
R



CDRA
8 Cyl. **4163 ccm**
Cyl. 84,5 Ø

A8
11/2009 → 12/2012

ES⊕ **520.780**

174.030
079 103 383 AR
L



174.020
079 103 383 AQ
R



ZKS 341.400
WHT 001 017 (8x)
M10x1,5x113
2x

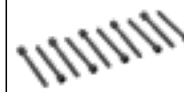

473.670
079 103 650 C
L



898.610
079 103 483 T
L



















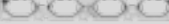





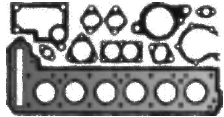
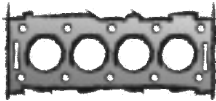

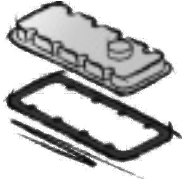

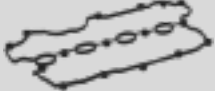

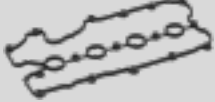
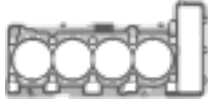
473.660
079 103 649 C
R

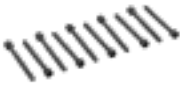



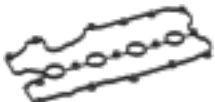















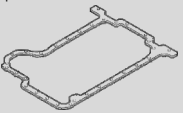



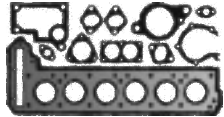
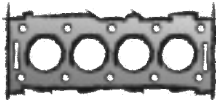

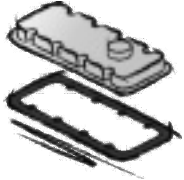
898.620
079 103 484 C
R











			<p>a) </p> <p>b) </p>	<p>K: </p> <p>N: </p>	
<p>VAS 235.610 FPM 2x</p> <p>724.590 036 109 675 A FPM 32x</p>	<p>130.130 079 253 039 F 2x</p> 	<p>473.650 079 133 074 B →11/2008 2x</p>  <p>225.170 079 129 717 B 11/2008→ 8x</p> 	<p>a) 030.793 Dirko HT</p> <p>b) 982.340 N 016 027 6 incl. 813.036 M 14x1,5x12</p> <p>b) 591.840 N 013 815.8 Metal C 14x20x2</p> <p>b) 813.036 N 013 815.6 CU C 14x20x2</p>	<p>K:← 173.890 079 103 051 G ASW RD PTFE/ACM 55x72x8</p> <p>K:→ 026.790 079 103 051 F ASW LD PTFE/FPM 85x105x8,8</p>	
<p>VAS 235.610 FPM 2x</p> <p>724.590 036 109 675 A FPM 32x</p>	<p>130.130 079 253 039 F 2x</p> 	<p>225.170 079 129 717 B 8x</p> 	<p>a) 030.793 Dirko HT</p> <p>b) 982.340 N 016 027 6 incl. 813.036 M 14x1,5x12</p> <p>b) 591.840 N 013 815.8 Metal C 14x20x2</p> <p>b) 813.036 N 013 815.6 CU C 14x20x2</p>	<p>K:← 173.890 079 103 051 G ASW RD PTFE/ACM 55x72x8</p> <p>K:→ 026.790 079 103 051 F ASW LD PTFE/FPM 85x105x8,8</p>	









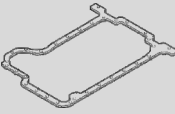
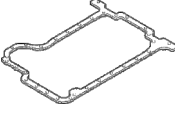
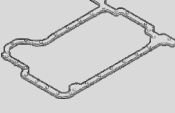

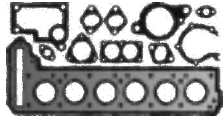
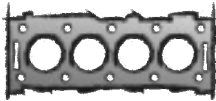
<p>AUDI</p> 				
<p>CFSA</p> <p>8 Cyl. 4163 ccm Cyl. 84,5 Ø</p> <p>A4 RS4 05/2012 → 08/2015</p> <p>A5 RS5 03/2010 → 01/2017</p>			<p>ZKS 341.400 WHT 001 017 (8x) M10x1,5x113 2x</p> 	<p>473.670 079 103 650 C L</p>  <p>898.610 079 103 483 T L</p>  <p>473.660 079 103 649 C R</p>  <p>898.620 079 103 484 C R</p> 
<p>CNDA</p> <p>8 Cyl. 4163 ccm Cyl. 84,5 Ø</p> <p>R8 07/2010 → 07/2015</p>		<p>174.030 079 103 383 AR L</p>  <p>174.020 079 103 383 AQ R</p> 	<p>ZKS 341.400 WHT 001 017 (8x) M10x1,5x113 2x</p> 	<p>473.670 079 103 650 C L</p>  <p>898.610 079 103 483 T L</p>  <p>473.660 079 103 649 C R</p>  <p>898.620 079 103 484 C R</p> 
<p>ABH</p> <p>8 Cyl. 4172 ccm Cyl. 84,5 Ø</p> <p>100 10/1992 → 07/1994</p> <p>100 S4 10/1992 → 07/1994</p> <p>V8 10/1991 → 02/1994</p>		<p>156.870 077 103 383 AD 1,75 mm $\frac{2}{3}$ 85,3 Ø L</p>  <p>156.830 077 103 383 AC 1,75 mm $\frac{2}{3}$ 85,3 Ø R</p> 	<p>ZKS 267.460 077 103 385 (10x) M 11x1,5x154 2x</p> 	

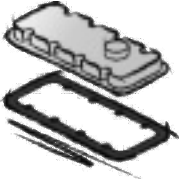











			<p>a) </p> <p>b) </p>	<p>K: </p> <p>N: </p>	
<p>VAS 235.610 FPM 2x</p> <p>724.590 036 109 675 A FPM 32x</p>	<p>548.930 079 253 039 G 2x</p> 		<p>a) 030.793 Dirko HT</p> <p>b) 982.340 N 016 027 6 incl. 813.036 M 14x1,5x12</p> <p>b) 591.840 N 013 815,8 Metal C 14x20x2</p> <p>b) 813.036 N 013 815,6 CU C 14x20x2</p>	<p>K:→ 026.790 079 103 051 F ASW LD PTFE/FPM 85x105x8,8</p>	
<p>VAS 235.610 FPM 2x</p> <p>724.590 036 109 675 A FPM 32x</p>	<p>130.130 079 253 039 F 2x</p> 	<p>473.650 079 133 074 B 2x</p> 	<p>a) 030.793 Dirko HT</p> <p>b) 110.353 N 013 812,8 CU A 12x15,5x1,5</p>	<p>K:← 263.600 079 103 051 D ASW RD PTFE/ACM 55x70x8</p> <p>K:→ 026.790 079 103 051 F ASW LD PTFE/FPM 85x105x8,8</p>	
<p>701.289 027 109 675 FPM 32x</p>			<p>a) 632.510 077 103 609 E ↑</p>  <p>b) 878.100 incl. 813.168 028 103 059 A M 24x1,5x10</p> <p>b) 812.773 N 013 850,3 FE C 24x32x2,5</p> <p>b) 813.168 CU C 24x32x2,5</p>	<p>K:← 294.357 069 115 147 E ASW RD FPM/ACM 35x48x10</p> <p>K:← 475.961 054 115 147 B ASW RD FPM 35x48x10</p> <p>N:← 325.155 068 103 085 E ASW WD FPM/ACM 32x47x10 2x</p>	







AUDI 				
ABZ AEM AGH 8 Cyl. 4172 ccm Cyl. 84,5 Ø A8 03/1994 → 11/1998		156.870 077 103 383 AD 1,75 mm \pm 85,3 Ø  L 156.830 077 103 383 AC 1,75 mm \pm 85,3 Ø  R	ZKS 267.460 077 103 385 (10x) M 11x1,5x154 2x 	
AEC 8 Cyl. 4172 ccm Cyl. 84,5 Ø A6 S6 06/1994 → 12/1997		156.870 077 103 383 AD 1,75 mm \pm 85,3 Ø  L 156.830 077 103 383 AC 1,75 mm \pm 85,3 Ø  R	ZKS 267.460 077 103 385 (10x) M 11x1,5x154 2x 	
AHC AHK AKG AKH 8 Cyl. 4172 ccm Cyl. 84,5 Ø A6 S6 plus 04/1996 → 12/1997 A8 03/1994 → 11/1998 A8 S8 07/1996 → 06/1999		156.870 077 103 383 AD 1,75 mm \pm 85,3 Ø  L 156.830 077 103 383 AC 1,75 mm \pm 85,3 Ø  R	ZKS 267.460 077 103 385 (10x) M 11x1,5x154 2x 	

AUDI

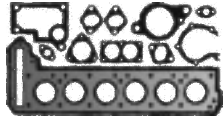
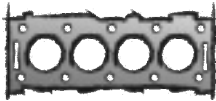

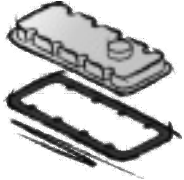
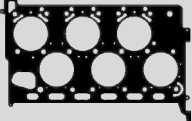

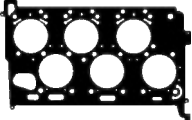
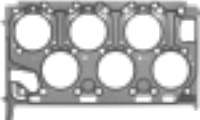





			<p>a) </p> <p>b) </p>	<p>K: </p> <p>N: </p>	
<p>VAS 235.610 FPM 4D-T-008 227→ 2x</p> <p>701.289 027 109 675 FPM →4D-T-008 226 32x</p> <p>724.590 036 109 675 A FPM 4D-T-008 227→ 32x</p>			<p>a) 632.510 077 103 609 E ↑ </p> <p>b) 878.100 incl. 813.168 028 103 059 A M 24x1,5x10</p> <p>b) 812.773 N 013 850.3 FE C 24x32x2,5</p> <p>b) 813.168 CU C 24x32x2,5</p>	<p>K:← 294.357 069 115 147 E ASW RD FPM/ACM 35x48x10</p> <p>K:← 475.961 054 115 147 B ASW RD FPM 35x48x10</p> <p>N:← 325.155 068 103 085 E ASW WD FPM/ACM 32x47x10 2x</p>	
<p>VAS 235.610 FPM 4A-T-075 001→ 2x</p> <p>701.289 027 109 675 FPM →4A-T-075 000 32x</p> <p>724.590 036 109 675 A FPM 4A-T-075 001→ 32x</p>			<p>a) 632.510 077 103 609 E ↑ </p> <p>b) 878.100 incl. 813.168 028 103 059 A M 24x1,5x10</p> <p>b) 812.773 N 013 850.3 FE C 24x32x2,5</p> <p>b) 813.168 CU C 24x32x2,5</p>	<p>K:← 294.357 069 115 147 E ASW RD FPM/ACM 35x48x10</p> <p>K:← 475.961 054 115 147 B ASW RD FPM 35x48x10</p> <p>N:← 325.155 068 103 085 E ASW WD FPM/ACM 32x47x10 2x</p>	
<p>VAS 235.610 FPM 2x</p> <p>724.590 036 109 675 A FPM 32x</p>			<p>a) 632.510 077 103 609 E ↑ </p> <p>b) 878.100 incl. 813.168 028 103 059 A M 24x1,5x10</p> <p>b) 812.773 N 013 850.3 FE C 24x32x2,5</p> <p>b) 813.168 CU C 24x32x2,5</p>	<p>K:← 294.357 069 115 147 E ASW RD FPM/ACM 35x48x10</p> <p>K:← 475.961 054 115 147 B ASW RD FPM 35x48x10</p> <p>N:← 325.155 068 103 085 E ASW WD FPM/ACM 32x47x10 2x</p>	

<p>AUDI</p> 				
<p>AKB ANK AQF AQH AQJ ARS ART ARU ASG AUW AUX AVP AWN AYS BBD BCS BFM BGK</p> <p>8 Cyl. 4172 ccm Cyl. 84,5 Ø</p> <p>A6 11/1998 → 01/2005 A6 S6 09/1999 → 01/2005 A8 11/1998 → 07/2010 A8 S8 06/1999 → 12/2004</p>			<p>ZKS 215.000 077 103 385 D (10x) M 10x1,5x115 2x</p> 	<p>ZKHS 255.570 077 198 025 A 2x</p> 
<p>BCY BRV</p> <p>8 Cyl. 4172 ccm Cyl. 84,5 Ø</p> <p>A6 RS6 07/2002 → 01/2005 A6 RS6 plus 04/2004 → 01/2005</p>			<p>ZKS 215.000 077 103 385 D (10x) M 10x1,5x115 2x</p> 	<p>ZKHS 255.570 077 198 025 A 2x</p> 
<p>BSM</p> <p>10 Cyl. 5204 ccm Cyl. 84,5 Ø</p> <p>A8 S8 06/2006 → 07/2010</p>		<p>522.430 07L 103 383 N L</p> <p>522.440 07L 103 383 P R</p> 	<p>ZKS 341.410 WHT 001 017 (12x) 2x</p> 	<p>750.710 07L 103 483 K L 10/2007→</p> <p>753.300 07L 103 484 H R 10/2007→</p>
<p>BUJ</p> <p>10 Cyl. 5204 ccm Cyl. 84,5 Ø</p> <p>R8 04/2009 → 07/2015</p>				<p>750.710 07L 103 483 K L</p> <p>753.300 07L 103 484 H R</p>
<p>BXA</p> <p>10 Cyl. 5204 ccm Cyl. 84,5 Ø</p> <p>A6 S6 03/2006 → 08/2011</p>		<p>522.430 07L 103 383 N L</p> <p>522.440 07L 103 383 P R</p> 	<p>ZKS 341.410 WHT 001 017 (12x) 2x</p> 	<p>750.710 07L 103 483 K L 4E-7-025 801→</p> <p>753.300 07L 103 484 H R 4E-7-025 801→</p>

			<p>a) </p> <p>b) </p>	<p>K: </p> <p>N: </p>	
<p>VAS 235.620 FPM 2x 724.590 036 109 675 A FPM 40x</p>	<p>530.930 077 253 039 C 2x </p>	<p>530.982 077 129 717 Q 2x </p>	<p>a) 030.793 Dirko HT b) 878.100 incl. 813.168 028 103 059 A M 24x1,5x10 b) 812.773 N 013 850.3 FE C 24x32x2,5 b) 813.168 CU C 24x32x2,5</p>	<p>K:← 690.110 077 115 147 A A/BS RD FPM 55x68x8 N:← 325.155 068 103 085 E ASW WD FPM/ACM 32x47x10 4x</p>	
<p>VAS 235.620 FPM 2x 724.590 036 109 675 A FPM 40x</p>	<p>530.930 077 253 039 C 2x </p>	<p>017.131 077 129 717 R 2x </p>	<p>a) 030.793 Dirko HT b) 878.100 incl. 813.168 028 103 059 A M 24x1,5x10 b) 812.773 N 013 850.3 FE C 24x32x2,5 b) 813.168 CU C 24x32x2,5</p>	<p>K:← 690.110 077 115 147 A A/BS RD FPM 55x68x8 N:← 325.155 068 103 085 E ASW WD FPM/ACM 32x47x10 4x</p>	
<p>VAS 235.620 FPM 2x 724.590 036 109 675 A FPM 40x</p>			<p>a) 030.793 Dirko HT b) 982.340 N 016 027 6 incl. 813.036 M 14x1,5x12 b) 591.840 N 013 815.8 Metal C 14x20x2 b) 813.036 N 013 815.6 CU C 14x20x2</p>	<p>K:← 173.890 079 103 051 G ASW RD PTFE/ACM 55x72x8 K:→ 026.790 079 103 051 F ASW LD PTFE/FPM 85x105x8,8</p>	
<p>VAS 235.620 FPM 2x 724.590 036 109 675 A FPM 40x</p>			<p>a) 030.793 Dirko HT b) 243.205 N 013 849.3 AL A 14x20x1,5</p>	<p>K:→ 026.790 079 103 051 F ASW LD PTFE/FPM 85x105x8,8</p>	
<p>VAS 235.620 FPM 2x 724.590 036 109 675 A FPM 40x</p>			<p>a) 030.793 Dirko HT b) 982.340 N 016 027 6 incl. 813.036 M 14x1,5x12 b) 591.840 N 013 815.8 Metal C 14x20x2 b) 813.036 N 013 815.6 CU C 14x20x2</p>	<p>K:← 173.890 079 103 051 G ASW RD PTFE/ACM 55x72x8 K:→ 026.790 079 103 051 F ASW LD PTFE/FPM 85x105x8,8</p>	

<p>AUDI</p> 				
<p>AZC</p> <p>12 Cyl. 5998 ccm Cyl. 84,0 Ø</p> <p>A8</p> <p>01/2001 → 09/2002</p>		<p>744.264 07C 103 148 N 0,64 mm \pm 84,7 Ø Cyl. 1-6</p> 		<p>901.490 07C 103 483 C L</p>  <p>900.380 07C 103 484 C R</p> 
<p>BHT BSB BTE</p> <p>12 Cyl. 5998 ccm Cyl. 84,0 Ø</p> <p>A8</p> <p>12/2003 → 07/2010</p>		<p>354.562 07C 103 148 T 0,67 mm \pm 84,9 Ø Cyl. 1-6 →10/2007</p>  <p>354.571 07C 103 149 Q 0,67 mm \pm 84,9 Ø Cyl. 7-12 →10/2007</p> 		<p>901.490 07C 103 483 C L</p>  <p>900.380 07C 103 484 C R</p> 

AUDI

			<p>a) </p> <p>b) </p>	<p>K: </p> <p>N: </p>	
<p>VAS 235.650 FPM 2x 724.590 036 109 675 A FPM 48x</p>	<p>710.802 07C 253 039 D 4x </p>		<p>a) 030.793 Dirko HT</p> <p>b) 567.640 N 908 132 01 M 14x1,5x22</p>	<p>K:← 655.340 06C 103 085 AW/BS RD PTFE/ACM 42x55x7</p> <p>K:→ 158.430 021 103 051 C ASW LD PTFE 85x105x11</p>	
<p>VAS 235.650 FPM 2x 724.590 036 109 675 A FPM 48x</p>	<p>710.802 07C 253 039 D 4x </p>		<p>a) 030.793 Dirko HT</p> <p>b) 567.640 N 908 132 01 M 14x1,5x22</p>	<p>K:← 655.340 06C 103 085 AW/BS RD PTFE/ACM 42x55x7</p> <p>K:→ 158.430 021 103 051 C ASW LD PTFE 85x105x11</p>	

AUDI (FAW)



AUDI (FAW)	ccm	kW	→	→	→	→
A3	4	1395	110	03/2014		CSSA 360 DJSA
A3	4	1798	132	01/2015		CUFA 364
A3	4	1984	140	04/2017		DBFB 368 DKVA
A3L	4	1395	110	01/2021		DJSA 360
A4	4	1781	120	02/2003	09/2008	BFB 362 BKB
A4	4	1984	147	07/2005	09/2008	BGB 364 BWE
A4	6	2393	125	01/2004	07/2005	BDV 370
A4	6	2976	160	02/2003	09/2008	BBJ 378
A4L	4	1395	110	09/2017		CVNA 360
A4L	4	1798	118	08/2009		CCUA 364
A4L	4	1984	132	11/2008	12/2016	CDZA 366 CUJA 368
A4L	4	1984	155	11/2008	12/2014	CADA 364
A4L	4	1984	165	06/2014		CUHA 368
A4L	4	1984	140	09/2016		CWNA 368 DKUA 370 DTAA
A4L	4	1984	185	09/2016		CWPA 368 DKWA
A4L	4	1984	110	10/2018		DKUB 368
A4L	6	2995	200	08/2012	12/2016	CHMB 378
A4L	6	3197	195	01/2009	12/2011	CALA 382
A6	4	1781	92	01/2000	12/2005	ADR 360
A6	4	1781	110	07/2000	12/2006	AWL 362 BGC
A6	6	2393	121	09/1999	12/2005	APS 370
A6	6	2393	125	06/2002	12/2005	BDV 370
A6	6	2496	132	08/2004	12/2005	BAU 372 BND
A6	6	2771	140	09/2000	07/2005	ATX 376 BBG
A6L	4	1798	140	01/2016	12/2018	CYYA 364
A6L	4	1984	125	09/2005	12/2012	BPJ 364
A6L	4	1984	132	01/2012	12/2016	CDNB 366 CDZA
A6L	4	1984	155	08/2017	12/2018	CPEA 366
A6L	4	1984	165	08/2017		CUHA 368 DKWB
A6L	4	1984	140	01/2019		DKUA 368 DKWC

AUDI (FAW)	ccm	kW	→	→	→	→
A6L	4	1984	185	01/2020		DPMA 370
A6L	4	1984	270	01/2020		DPMA 370
A6L	6	2393	130	03/2005	12/2012	BDW 372
A6L	6	2498	140	01/2012	12/2016	CLXA 374
A6L	6	2498	150	01/2016	12/2018	CLXB 374
A6L	6	2699	140	08/2009	12/2012	CANA 374
A6L	6	2773	154	11/2007	12/2008	BDX 376
A6L	6	2773	162	01/2008	12/2016	CCE 376 CCEA 378 CNYB
A6L	6	2976	160	03/2005	12/2006	BBJ 378
A6L	6	2995	213	09/2008	12/2012	CAJA 378
A6L	6	2995	220	01/2012	01/2014	CHMA 378
A6L	6	2995	228	01/2014	12/2016	CTTA 378
A6L	6	2995	200	01/2016	12/2018	CTDB 380
A6L	6	2995	245	01/2016	12/2018	CREC 380
A6L	6	2995	250	01/2019		DLZA 380
A6L	6	3123	188	09/2005	12/2008	AUK 382
A6L	8	4163	246	09/2005	12/2006	BAT 382
A6L	8	4163	257	11/2006	10/2008	BVJ 384
Q2L	4	1395	110	10/2018		DJSA 360
Q3	4	1395	110	04/2014		CSSA 360 DJSA
Q3	4	1984	125	04/2013		CRHA 366
Q3	4	1984	147	04/2013	12/2016	CGMA 366
Q3	4	1984	132	04/2016		DBRA 368
Q3	4	1984	162	04/2016		DBSA 368 DKXA 370
Q3	4	1984	137	04/2019		DKVB 368 DPLA
Q5	4	1984	155	03/2010	12/2015	CADA 364
Q5	4	1984	132	04/2013	12/2015	CDZA 366
Q5	4	1984	165	11/2014		CUHA 368
Q5	4	1984	169	08/2016		CUHB 368
Q5L	4	1984	140	07/2018		CWNA 368 DKUA 370 DTAA
Q5L	4	1984	185	07/2018		CWPB 368 DKWA

AUDI (FAW)



Das Original

AUDI (FAW)

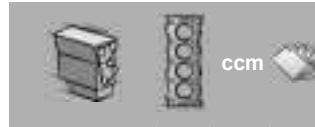
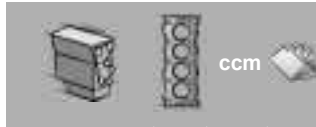

ADR	4	1781	360
APS	6	2393	370
ATX	6	2771	376
AUK	6	3123	382
AWL	4	1781	362
BAT	8	4163	382
BAU	6	2496	372
BBG	6	2771	376
BBJ	6	2976	378
BDV	6	2393	370
BDW	6	2393	372
BDX	6	2773	376
BFB	4	1781	362
BGB	4	1984	364
BGC	4	1781	362
BKB	4	1781	362
BND	6	2496	372
BPJ	4	1984	364
BVJ	8	4163	384
BWE	4	1984	364
CAD	4	1984	364
CADA	4	1984	364
CAE	4	1984	366
CAEB	4	1984	366
CAJ	6	2995	378
CAJA	6	2995	378
CAL	6	3197	382
CALA	6	3197	382
CAN	6	2698	374
CANA	6	2698	374
CCE	6	2773	376
CCEA	6	2773	376
CCUA	4	1798	364
CDN	4	1984	366
CDNB	4	1984	366
CDNC	4	1984	366
CDZ	4	1984	366

CDZA	4	1984	366
CGM	4	1984	366
CGMA	4	1984	366
CHM	6	2995	378
CHMA	6	2995	378
CHMB	6	2995	378
CLX	6	2498	374
CLXA	6	2498	374
CLXB	6	2498	374
CNY	6	2773	378
CNYA	6	2773	378
CNYB	6	2773	378
CPEA	4	1984	366
CREC	6	2995	380
CRH	4	1984	366
CRHA	4	1984	366
CSS	4	1395	360
CSSA	4	1395	360
CTDB	6	2995	380
CTT	6	2995	378
CTTA	6	2995	378
CUF	4	1798	364
CUFA	4	1798	364
CUH	4	1984	368
CUHA	4	1984	368
CUHB	4	1984	368
CUJ	4	1984	368
CUJA	4	1984	368
CVN	4	1395	360
CVNA	4	1395	360
CWNA	4	1984	368
CWP	4	1984	368
CWPA	4	1984	368
CWPB	4	1984	368
CYYA	4	1798	364
DBFB	4	1984	368
DBR	4	1984	368







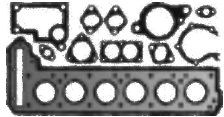
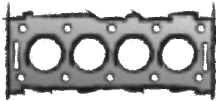

DBRA	4	1984	368
DBS	4	1984	368
DBSA	4	1984	368
DJSA	4	1395	360
DKUA	4	1984	368
DKUB	4	1984	368
DKVA	4	1984	368
DKVB	4	1984	368
DKWA	4	1984	368
DKWB	4	1984	368
DKWC	4	1984	368
DKXA	4	1984	370
DLZA	6	2995	380
DPLA	4	1984	368
DPMA	4	1984	370
DTAA	4	1984	370

AUDI (FAW)

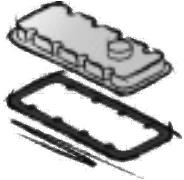
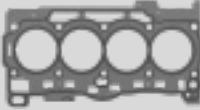
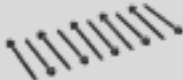
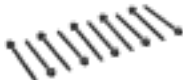
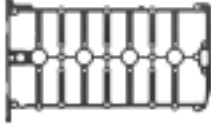





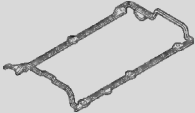
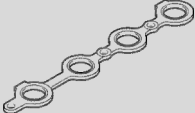









AUDI (FAW)



<p>AUDI (FAW)</p> 				
<p>CSS DJSA CSSA</p> <p>4 Cyl. 1395 ccm Cyl. 74,5 Ø</p> <p>A3 03/2014 →</p> <p>A3L 01/2021 →</p> <p>Q2L 10/2018 →</p> <p>Q3 04/2014 →</p>		<p>721.972 04E 103 383 AM 1,02 mm $\frac{2}{3}$ 75,5 Ø</p> 	<p>ZKS 445.910 WHT 007 089 (10x) M 9x1,25x140</p> 	
<p>CVN CVNA</p> <p>4 Cyl. 1395 ccm Cyl. 74,5 Ø</p> <p>A4L 09/2017 →</p>	<p>ES⊕ 446.900 CS* 523.430</p>	<p>311.040 04E 103 383 CA 0,80 mm $\frac{2}{3}$ 75,5 Ø</p>	<p>ZKS 445.910 WHT 007 089 (10x) M 9x1,25x140</p> 	<p>898.042 04E 103 483 H</p> 
<p>ADR</p> <p>4 Cyl. 1781 ccm Cyl. 81,0 Ø</p> <p>A6 01/2000 → 12/2005</p>	<p>ES⊕ 183.890 ● 058 198 012</p>  <p>ES⊕ 264.730 058 198 012 +058 198 025 A</p> <p>CS* 670.730 058 198 011</p> <p>SZ 863.590 058 198 217</p> 	<p>366.670 058 103 383 Q 1,22 mm $\frac{2}{3}$ 82,5 Ø</p> 	<p>ZKS 104.930 058 103 385 A (10x) M 11x1,5x96</p> 	<p>ZKHS 633.350 058 198 025 A</p>  <p>476.020 058 103 483 F</p>  <p>476.030 058 103 484 C</p> 

AUDI (FAW)

			<p>a) </p> <p>b) </p>	<p>K: </p> <p>N: </p>	
	<p>223.440 04E 253 039 E</p> 	<p>470.370 036 129 717 E 4x</p> 	<p>a) 030.793 Dirko HT</p>	<p>N:← 242.650 04E 103 085 AF ASW RD PTFE/ACM 36x46x7 2x</p> <p>N:→ 242.620 04E 103 085 ASW LD PTFE 24x39x8</p>	
<p>302.890 04E 109 675 FPM E 8x</p> <p>308.610 04E 109 675 A FPM A 8x</p>	<p>223.440 04E 253 039 E</p> 	<p>470.370 036 129 717 E 4x</p> 	<p>a) 030.793 Dirko HT ↑</p> <p>a) 478.660 04E 103 609</p>  <p>b) 588.690 06L 103 801</p>	<p>K:← 248.270 04C 103 085 ASW RD PTFE 30x40x7</p> <p>K:→ 523.120 04E 103 170 A IWD LD PTFE/ACM 85</p> <p>N:← 242.650 04E 103 085 AF ASW RD PTFE/ACM 36x46x7 2x</p> <p>N:→ 242.620 04E 103 085 ASW LD PTFE 24x39x8</p>	
<p>VAS 235.620 FPM</p> <p>724.590 036 109 675 A FPM 20x</p>	<p>148.190 058 253 039 L</p> 	<p>497.230 058 129 717 C 4x</p> 	<p>a) 030.793 Dirko HT</p> <p>b) 567.640 N 908 132 01 M 14x1,5x22</p>	<p>K:← 129.780 038 103 085 C ASW RD PTFE/ACM 32x47x10</p> <p>K:← 325.155 068 103 085 E ASW WD FPM/ACM 32x47x10</p> <p>K:→ 342.093 068 103 051 P ASW LD FPM 85x105x11</p> <p>K:→ 804.850 028 103 171 K SP LD PTFE/ACM 85</p> <p>K:→ 829.056 068 198 171 ASW LD FPM 85x105x11</p> <p>N:← 129.780 038 103 085 C ASW RD PTFE/ACM 32x47x10 2x</p> <p>N:← 325.155 068 103 085 E ASW WD FPM/ACM 32x47x10 2x</p>	

AUDI (FAW)

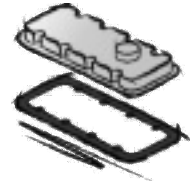
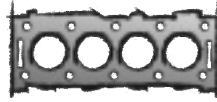
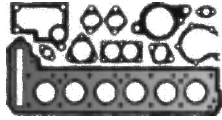

AWL
4 Cyl. **1781 ccm**
Cyl. 81,0 Ø

A6
07/2000 → 12/2006

ES⊕ **461.380**
CS* **292.011**
SZ **863.590**
058 198 217



366.670
058 103 383 Q
1,22 mm $\frac{1}{2}$ 82,5 Ø



ZKS 130.830
06A 103 385 A (10x)
M 10x1,5x115



ZKHS 633.350
058 198 025 A



476.020
058 103 483 F

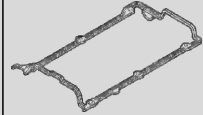

476.030
058 103 484 C



BGC
4 Cyl. **1781 ccm**
Cyl. 81,0 Ø

A6
07/2000 → 12/2006

ES⊕ **461.380**
CS **530.580**
06A 198 011 A
SZ **863.590**
058 198 217



366.670
058 103 383 Q
1,22 mm $\frac{1}{2}$ 82,5 Ø



ZKS 130.830
06A 103 385 A (10x)
M 10x1,5x115



ZKHS 633.350
058 198 025 A



476.020
058 103 483 F

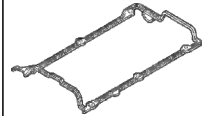

476.030
058 103 484 C



BFB
BKB
4 Cyl. **1781 ccm**
Cyl. 81,0 Ø

A4
02/2003 → 09/2008

ES⊕ **461.380**
→8E-3-500 000
ES⊕ **729.861**
8E-4-000 001→
CS **530.580**
06A 198 011 A
SZ **863.590**
058 198 217



366.670
058 103 383 Q
1,22 mm $\frac{1}{2}$ 82,5 Ø



ZKS 130.830
06A 103 385 A (10x)
M 10x1,5x115



ZKHS 633.350
058 198 025 A





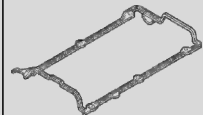













476.020
058 103 483 F







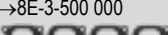

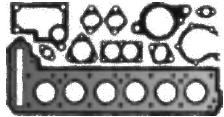
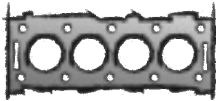

476.030
058 103 484 C

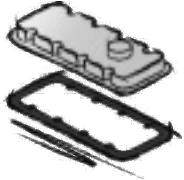
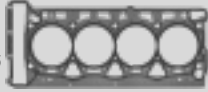

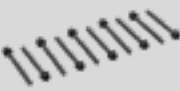

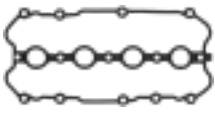





















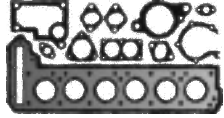
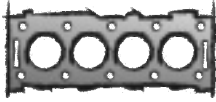

AUDI (FAW)

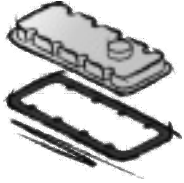
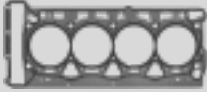
			<p>a) </p> <p>b) </p>	<p>K: </p> <p>N: </p>	
<p>VAS 235.620 FPM 724.590 036 109 675 A FPM 20x</p>	<p>148.190 058 253 039 L </p>	<p>476.460 058 129 717 D </p>	<p>a) 030.793 Dirko HT</p> <p>b) 243.205 N 013 849.3 AL A 14x20x1,5</p>	<p>K:← 155.560 038 103 085 E ASW RD PTFE/ACM 35x48x10</p> <p>K:← 475.961 054 115 147 B ASW RD FPM 35x48x10</p> <p>K:→ 012.370 06A 103 171 A IWD LD PTFE/ACM 85</p> <p>N:← 129.780 038 103 085 C ASW RD PTFE/ACM 32x47x10 2x</p> <p>N:← 325.155 068 103 085 E ASW WD FPM/ACM 32x47x10 2x</p>	<p>TLS 703.960 </p>
<p>VAS 235.620 FPM 724.590 036 109 675 A FPM 20x</p>	<p>148.190 058 253 039 L </p>	<p>476.460 058 129 717 D </p>	<p>a) 030.793 Dirko HT</p> <p>b) 243.205 N 013 849.3 AL A 14x20x1,5</p>	<p>K:← 155.560 038 103 085 E ASW RD PTFE/ACM 35x48x10</p> <p>K:← 475.961 054 115 147 B ASW RD FPM 35x48x10</p> <p>K:→ 012.370 06A 103 171 A IWD LD PTFE/ACM 85</p> <p>N:← 129.780 038 103 085 C ASW RD PTFE/ACM 32x47x10 2x</p> <p>N:← 325.155 068 103 085 E ASW WD FPM/ACM 32x47x10 2x</p>	<p>TLS 703.960 </p>
<p>VAS 235.620 FPM 724.590 036 109 675 A FPM 20x</p>	<p>148.190 058 253 039 L </p>	<p>476.460 058 129 717 D →8E-3-500 000 </p> <p>080.990 06B 129 717 F 8E-4-000 001→ </p>	<p>a) 030.793 Dirko HT</p> <p>b) 567.640 N 908 132 01 M 14x1,5x22</p>	<p>K:← 155.560 038 103 085 E ASW RD PTFE/ACM 35x48x10</p> <p>K:→ 012.370 06A 103 171 A IWD LD PTFE/ACM 85</p> <p>N:← 129.780 038 103 085 C ASW RD PTFE/ACM 32x47x10 2x</p>	<p>TLS 703.960 </p>

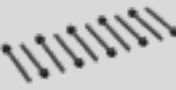
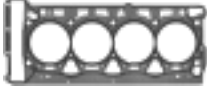

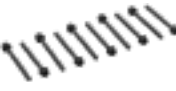
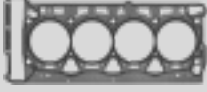

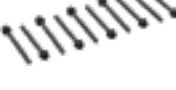















AUDI (FAW) 				
CCUA 4 Cyl. 1798 ccm Cyl. 82,5 Ø A4L 08/2009 →	ES⊕ 244.891 CS* 903.201	685.662 06H 103 383 AF 0,90 mm $\frac{\pm}{\pm}$ 83,3 Ø 	ZKS 325.930 06D 103 385 D (10x) M 10x1,5x117 →10/2012  ZKS 323.300 WHT 005 305 (10x) M10x1,5x115 10/2012→ 	461.682 EL-Liq 74
CUF CUFA 4 Cyl. 1798 ccm Cyl. 82,5 Ø A3 01/2015 →		915.050 06J 103 383 L		461.682 EL-Liq 74
CYYA 4 Cyl. 1798 ccm Cyl. 82,5 Ø A6L 01/2016 → 12/2018		915.160 06K 103 383 AH		
BGB BPJ BWE 4 Cyl. 1984 ccm Cyl. 82,5 Ø A4 07/2005 → 09/2008 A6L 09/2005 → 12/2012	ES⊕ 718.440 CS* 178.580	376.843 06F 103 383 J 0,90 mm $\frac{\pm}{\pm}$ 83,3 Ø 	ZKS 325.930 06D 103 385 D (10x) M 10x1,5x117 	497.240 06F 103 483 D  461.682 EL-Liq 74 ↓
CAD CADA 4 Cyl. 1984 ccm Cyl. 82,5 Ø A4L 11/2008 → 12/2014 Q5 03/2010 → 12/2015	ES⊕ 244.891 CS* 903.201	685.662 06H 103 383 AF 0,90 mm $\frac{\pm}{\pm}$ 83,3 Ø 	ZKS 325.930 06D 103 385 D (10x) M 10x1,5x117 	461.682 EL-Liq 74



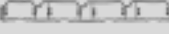

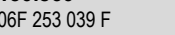
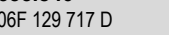

AUDI (FAW)

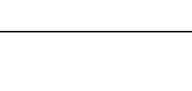

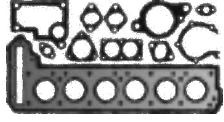
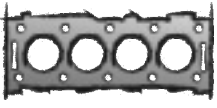

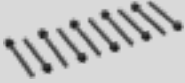

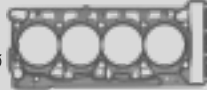
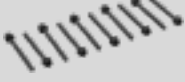

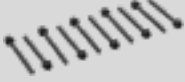



			<p>a) </p> <p>b) </p>	<p>K: </p> <p>N: </p>	
<p>VAS 235.610 FPM 724.590 036 109 675 A FPM 16x</p>	<p>150.860 06F 253 039 F </p>	<p>655.840 06F 129 717 D </p>	<p>a) 030.793 Dirko HT b) 567.640 N 908 132 01 M 14x1,5x22</p>	<p>K:← 248.300 06L 103 085 B ASW RD PTFE/ACM 45x60x8 K:→ 798.660 06K 103 171 G SP LD PTFE/ACM</p>	
<p>VAS 235.610 FPM 724.590 036 109 675 A FPM 16x</p>			<p>a) 030.793 Dirko HT b) 591.840 N 013 815.8 Metal C 14x20x2 b) 813.036 N 013 815.6 CU C 14x20x2</p>	<p>K:← 248.300 06L 103 085 B ASW RD PTFE/ACM 45x60x8 K:→ 798.660 06K 103 171 G SP LD PTFE/ACM</p>	
<p>VAS 235.610 FPM 724.590 036 109 675 A FPM 16x</p>	<p>150.860 06F 253 039 F </p>	<p>655.840 06F 129 717 D </p>	<p>a) 030.793 Dirko HT b) 567.640 N 908 132 01 M 14x1,5x22</p>	<p>K:← 155.560 038 103 085 E ASW RD PTFE/ACM 35x48x10 K:→ 012.370 06A 103 171 A IWD LD PTFE/ACM 85 N:← 129.780 038 103 085 C ASW RD PTFE/ACM 32x47x10</p>	<p>TLS 261.190 </p>
<p>VAS 235.610 FPM 724.590 036 109 675 A FPM 16x</p>	<p>150.860 06F 253 039 F </p>	<p>655.840 06F 129 717 D </p>	<p>a) 030.793 Dirko HT b) 567.640 N 908 132 01 M 14x1,5x22</p>	<p>K:← 248.300 06L 103 085 B ASW RD PTFE/ACM 45x60x8 K:→ 798.660 06K 103 171 G SP LD PTFE/ACM</p>	<p>TLS 948.660 </p>

AUDI (FAW)					
					
CAE CDN CDNC 4 Cyl. 1984 ccm Cyl. 82,5 Ø A6L 01/2012 → 12/2016	CAEB CDNB	ES⊕ 244.891 CS* 903.201	685.662 06H 103 383 AF 0,90 mm $\frac{\pm}{\pm}$ 83,3 Ø 	ZKS 325.930 06D 103 385 D (10x) M 10x1,5x117 →10/2012  ZKS 323.300 WHT 005 305 (10x) M10x1,5x115 10/2012→ 	461.682 EL-Liq 74
CDZ CDZA 4 Cyl. 1984 ccm Cyl. 82,5 Ø A4L 11/2008 → 12/2016 A6L 01/2012 → 12/2016 Q5 04/2013 → 12/2015		ES⊕ 244.891 CS* 903.201	685.662 06H 103 383 AF 0,90 mm $\frac{\pm}{\pm}$ 83,3 Ø 	ZKS 325.930 06D 103 385 D (10x) M 10x1,5x117 →10/2012  ZKS 323.300 WHT 005 305 (10x) M10x1,5x115 10/2012→ 	461.682 EL-Liq 74
CGM CGMA 4 Cyl. 1984 ccm Cyl. 82,5 Ø Q3 04/2013 → 12/2016		ES⊕ 766.790 CS* 903.201	685.662 06H 103 383 AF 0,90 mm $\frac{\pm}{\pm}$ 83,3 Ø 	ZKS 325.930 06D 103 385 D (10x) M 10x1,5x117 	461.682 EL-Liq 74
CPEA 4 Cyl. 1984 ccm Cyl. 82,5 Ø A6L 08/2017 → 12/2018			685.662 06H 103 383 AF 0,90 mm $\frac{\pm}{\pm}$ 83,3 Ø 	ZKS 323.300 WHT 005 305 (10x) M10x1,5x115 	461.682 EL-Liq 74
CRH CRHA 4 Cyl. 1984 ccm Cyl. 82,5 Ø Q3 04/2013 →		ES⊕ 244.891 CS* 903.201	685.662 06H 103 383 AF 0,90 mm $\frac{\pm}{\pm}$ 83,3 Ø 	ZKS 325.930 06D 103 385 D (10x) M 10x1,5x117 	461.682 EL-Liq 74

AUDI (FAW)

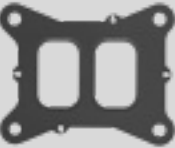
			<p>a) </p> <p>b) </p>	<p>K: </p> <p>N: </p>	
<p>VAS 235.610 FPM 724.590 036 109 675 A FPM 16x</p>	<p>150.860 06F 253 039 F </p>	<p>655.840 06F 129 717 D </p>	<p>a) 030.793 Dirko HT</p> <p>b) 567.640 N 908 132 01 M 14x1,5x22</p> <p>b) 858.050 M 14x1,5x15</p> <p>b) 591.840 N 013 815.8 Metal C 14x20x2</p>	<p>K:← 248.300 06L 103 085 B ASW RD PTFE/ACM 45x60x8</p> <p>K:→ 798.660 06K 103 171 G SP LD PTFE/ACM</p>	<p>TLS 948.660 </p>
<p>VAS 235.610 FPM 724.590 036 109 675 A FPM 16x</p>	<p>150.860 06F 253 039 F </p>	<p>655.840 06F 129 717 D </p>	<p>a) 030.793 Dirko HT</p> <p>b) 567.640 N 908 132 01 M 14x1,5x22</p>	<p>K:← 248.300 06L 103 085 B ASW RD PTFE/ACM 45x60x8</p> <p>K:→ 798.660 06K 103 171 G SP LD PTFE/ACM</p>	
<p>VAS 235.610 FPM 724.590 036 109 675 A FPM 16x</p>	<p>150.860 06F 253 039 F </p>	<p>655.840 06F 129 717 D </p>	<p>a) 030.793 Dirko HT</p> <p>b) 567.640 N 908 132 01 M 14x1,5x22</p>	<p>K:← 248.300 06L 103 085 B ASW RD PTFE/ACM 45x60x8</p> <p>K:→ 798.660 06K 103 171 G SP LD PTFE/ACM</p>	<p>TLS 261.160 </p>
<p>VAS 235.610 FPM 724.590 036 109 675 A FPM 16x</p>	<p>150.860 06F 253 039 F </p>	<p>655.840 06F 129 717 D </p>	<p>a) 030.793 Dirko HT</p> <p>b) 591.840 N 013 815.8 Metal C 14x20x2</p> <p>b) 813.036 N 013 815.6 CU C 14x20x2</p>	<p>K:← 248.300 06L 103 085 B ASW RD PTFE/ACM 45x60x8</p> <p>K:→ 798.660 06K 103 171 G SP LD PTFE/ACM</p>	<p>TLS 261.160 </p>
<p>VAS 235.610 FPM 724.590 036 109 675 A FPM 16x</p>	<p>150.860 06F 253 039 F </p>	<p>655.840 06F 129 717 D </p>	<p>a) 030.793 Dirko HT</p> <p>b) 567.640 N 908 132 01 M 14x1,5x22</p>	<p>K:← 248.300 06L 103 085 B ASW RD PTFE/ACM 45x60x8</p> <p>K:→ 798.660 06K 103 171 G SP LD PTFE/ACM</p>	<p>TLS 261.160 </p>

<p>AUDI (FAW)</p> 				
<p>CUH CUHB CUJA CUHA CUJ</p> <p>4 Cyl. 1984 ccm Cyl. 82,5 Ø</p> <p>A4L 11/2008 →</p> <p>A6L 08/2017 → 12/2018</p> <p>Q5 11/2014 →</p>		<p>915.160 06K 103 383 AH</p>	<p>ZKS 323.300 WHT 005 305 (10x) M10x1,5x115</p> 	<p>461.682 EL-Liq 74</p>
<p>CWNA CWPA CWP CWPB</p> <p>4 Cyl. 1984 ccm Cyl. 82,5 Ø</p> <p>A4L 09/2016 →</p> <p>Q5L 07/2018 →</p>		<p>008.040 06K 103 383 K 0,90 mm $\frac{1}{2}$ 83,3 Ø</p> 		<p>461.682 EL-Liq 74</p>
<p>DBR DBS DBRA DBSA</p> <p>4 Cyl. 1984 ccm Cyl. 82,5 Ø</p> <p>Q3 04/2016 →</p>		<p>008.040 06K 103 383 K 0,90 mm $\frac{1}{2}$ 83,3 Ø</p> 	<p>ZKS 323.300 WHT 005 305 (10x) M10x1,5x115</p> 	<p>461.682 EL-Liq 74</p>
<p>DKUA DKWA DKWC DKUB DKWB</p> <p>4 Cyl. 1984 ccm Cyl. 82,5 Ø</p> <p>A4L 09/2016 →</p> <p>A6L 01/2019 →</p> <p>Q5L 07/2018 →</p>		<p>915.160 06K 103 383 AH</p> <p>008.040 06K 103 383 K 0,90 mm $\frac{1}{2}$ 83,3 Ø</p> 		<p>461.682 EL-Liq 74</p>
<p>DBFB DKVB DKVA DPLA</p> <p>4 Cyl. 1984 ccm Cyl. 82,5 Ø</p> <p>A3 04/2017 →</p> <p>Q3 04/2019 →</p>		<p>915.160 06K 103 383 AH</p>	<p>ZKS 323.300 WHT 005 305 (10x) M10x1,5x115</p> 	<p>461.682 EL-Liq 74</p>

			<p>a) </p> <p>b) </p>	<p>K: </p> <p>N: </p>	
<p>VAS 235.610 FPM 724.590 036 109 675 A FPM 16x</p>	<p>691.780 06L 253 039</p> 	<p>297.590 06K 129 717 A</p> 	<p>a) 030.793 Dirko HT</p>	<p>K:← 248.300 06L 103 085 B ASW RD PTFE/ACM 45x60x8 K:→ 798.660 06K 103 171 G SP LD PTFE/ACM</p>	
			<p>b) 588.690 06L 103 801</p>		
<p>797.560 FPM A 8x</p>	<p>691.780 06L 253 039</p> 	<p>032.900 06K 129 717 D</p>	<p>a) 030.793 Dirko HT ↑ b) 982.340 N 016 027 6 incl. 813.036 M 14x1,5x12 b) 591.840 N 013 815.8 Metal C 14x20x2</p>	<p>K:→ 798.660 06K 103 171 G SP LD PTFE/ACM</p>	
			<p>b) 588.690 06L 103 801</p>		
	<p>223.440 04E 253 039 E</p> 		<p>a) 030.793 Dirko HT b) 591.840 N 013 815.8 Metal C 14x20x2 b) 813.036 N 013 815.6 CU C 14x20x2</p>	<p>K:← 248.300 06L 103 085 B ASW RD PTFE/ACM 45x60x8 K:→ 798.660 06K 103 171 G SP LD PTFE/ACM</p>	

AUDI (FAW)

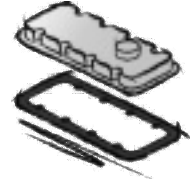
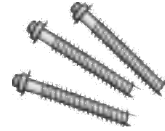
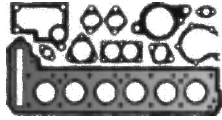

DKXA DPMA
DTAA

4 Cyl. **1984 ccm**
Cyl. 82,5 Ø

A4L 09/2016 →
A6L 01/2020 →
Q3 04/2019 →
Q5L 11/2020 →

915.160
06K 103 383 AH

APS

6 Cyl. **2393 ccm**
Cyl. 81,0 Ø

A6 09/1999 → 12/2005

ES **470.660**
078 198 012 G
2x
CS* **539.200**
SZ **863.590**
058 198 217
2x



212.410
078 103 383 K
1,40 mm \pm 83,5 Ø
2x



ZKS 130.850
078 103 385 K (8x)
M 11x1,5x133
2x



ZKHS 040.050
078 198 025
2x



413.830
078 103 484 C
2x

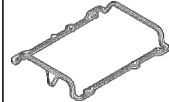

413.860
078 103 483 M
2x



BDV

6 Cyl. **2393 ccm**
Cyl. 81,0 Ø

A4 01/2004 → 07/2005
A6 06/2002 → 12/2005

ES **470.660**
078 198 012 G
CS* **539.200**
SZ **863.590**
058 198 217
2x



212.410
078 103 383 K
1,40 mm \pm 83,5 Ø
2x



ZKS 130.850
078 103 385 K (8x)
M 11x1,5x133
2x



ZKHS 040.050
078 198 025
2x





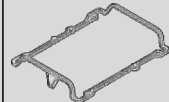









413.830
078 103 484 C
2x



413.860
078 103 483 M
2x



AUDI (FAW)

			<p>a) </p> <p>b) </p>	<p>K: </p> <p>N: </p>	
<p>VAS 057.070 FPM 724.590 036 109 675 A FPM 30x</p>	<p>433.250 078 253 039 G 2x </p>	<p>413.900 078 129 717 J 2x </p>	<p>a) 030.793 Dirko HT</p> <p>a) 467.762 078 103 610 E →4B-X-080 000 </p> <p>b) 567.640 N 908 132 01 M 14x1,5x22</p>	<p>K:← 155.560 038 103 085 E ASW RD PTFE/ACM 35x48x10</p> <p>K:← 294.357 069 115 147 E ASW RD FPM/ACM 35x48x10</p> <p>K:← 475.961 054 115 147 B ASW RD FPM 35x48x10</p> <p>K:→ 342.093 068 103 051 P ASW LD FPM 85x105x11</p> <p>K:→ 728.880 078 103 051 G 070 103 051 A AW/BS LD PTFE/ACM 85x105x12</p> <p>K:→ 829.056 068 198 171 ASW LD FPM 85x105x11</p> <p>N:← 325.155 068 103 085 E ASW WD FPM/ACM 32x47x10 4x</p>	
<p>VAS 057.070 FPM 724.590 036 109 675 A FPM 30x</p>	<p>433.250 078 253 039 G 2x </p>	<p>413.900 078 129 717 J 2x </p>	<p>a) 030.793 Dirko HT</p> <p>b) 567.640 N 908 132 01 M 14x1,5x22</p>	<p>K:← 155.560 038 103 085 E ASW RD PTFE/ACM 35x48x10</p> <p>K:→ 728.880 078 103 051 G 070 103 051 A AW/BS LD PTFE/ACM 85x105x12</p> <p>N:← 325.155 068 103 085 E ASW WD FPM/ACM 32x47x10 4x</p>	

AUDI (FAW)

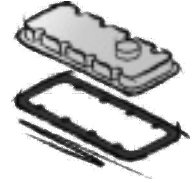
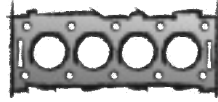
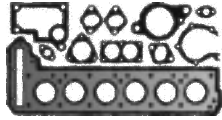

BDW
6 Cyl. **2393 ccm**
Cyl. 81,0 Ø

A6L
03/2005 → 12/2012

ES⊕ **249.570**
CS* **244.710**

715.830
06E 103 148 P
82,5 Ø
Cyl. 1-3
715.840
06E 103 149 P
82,5 Ø
Cyl. 4-6

ZKS 325.040
06E 103 385 E (8x)
M 10x1,5x172
2x

461.682
EL-Liq 74
↓
725.860
06E 103 483 G
Cyl. 4-6

725.870
06E 103 484 G
Cyl. 1-3

720.220
06E 103 649 E
↓ Cyl. 1-3

720.230
06E 103 650 A
↓ Cyl. 4-6

**BAU
BND**
6 Cyl. **2496 ccm**
Cyl. 78,3 Ø

A6
08/2004 → 12/2005















ES⊕ **439.041**
2x

CS* **295.500**











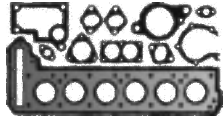
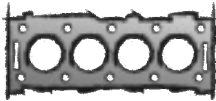

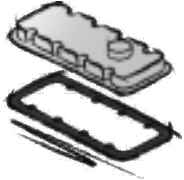
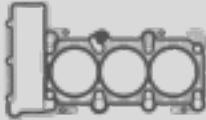

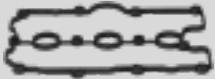
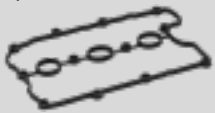





447.472
059 103 383 BQ
0,390 mm
→
0,490 mm
1,10 mm $\frac{\pm}{\pm}$ 79 Ø
1 ▽
2x
447.482
059 103 383 BR
0,490 mm
→
0,540 mm
1,15 mm $\frac{\pm}{\pm}$ 79 Ø
2 ▽
2x
447.492
059 103 383 BS
0,540 mm
→
0,650 mm
1,20 mm $\frac{\pm}{\pm}$ 79 Ø
3 ▽
2x







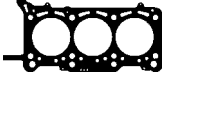

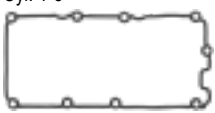



ZKS 130.110
057 103 384 A (8x)
M 12x1,5x159
2x

ZKHS 389.420
059 198 025
2x

AUDI (FAW)

			<p>a) </p> <p>b) </p>	<p>K: </p> <p>N: </p>	
<p>VAS 235.650 FPM 724.590 036 109 675 A FPM 24x</p>	<p>724.250 06E 253 039 C 2x </p>	<p>232.910 06E 198 717 6x </p>	<p>a) 030.793 Dirko HT</p> <p>b) 567.640 N 908 132 01 M 14x1,5x22</p> <p>b) 982.340 N 016 027 6 incl. 813.036 M 14x1,5x12</p> <p>b) 591.840 N 013 815.8 Metal C 14x20x2</p> <p>b) 813.036 N 013 815.6 CU C 14x20x2</p>	<p>K:← 728.550 06E 103 153 E SP RD PTFE 45x60</p> <p>K:→ 026.790 079 103 051 F ASW LD PTFE/FPM 85x105x8,8</p>	
<p>VAS 235.650 FPM 724.590 036 109 675 A FPM 24x</p>	<p>231.240 059 253 039 B 6x </p>	<p>422.890 059 129 717 G 2x </p>	<p>a) 030.793 Dirko HT</p> <p>a) 422.880 059 103 610 B </p> <p>b) 243.205 N 013 849.3 AL A 14x20x1,5</p>	<p>K:← 475.961 054 115 147 B ASW RD FPM 35x48x10</p> <p>K:→ 728.880 078 103 051 G 070 103 051 A AW/BS LD PTFE/ACM 85x105x12</p> <p>K:→ 750.330 059 103 171 D SP LD PTFE/ACM 85x15</p> <p>N:← 325.155 068 103 085 E ASW WD FPM/ACM 32x47x10 2x</p>	<p>TLS 704.050 </p>

AUDI (FAW) 				
CLX CLXB 6 Cyl. 2498 ccm Cyl. 80,2 Ø A6L 01/2012 → 12/2018	ES⊕ 589.650 CS* 783.930	589.600 06E 103 148 AJ 81 Ø Cyl. 1-3 589.660 06E 103 149 AJ 81 Ø Cyl. 4-6 	ZKS 223.890 WHT 005 739 (8x) M 10x1,5x170 2x 	461.682 EL-Liq 74 ↓ 429.910 06E 103 483 Q Cyl. 4-6  429.980 06E 103 484 P Cyl. 1-3 
CAN CANA 6 Cyl. 2698 ccm Cyl. 83,0 Ø A6L 08/2009 → 12/2012	ES⊕ 339.601  CS* 397.230 OKS 810.550 	735.470 059 103 383 ES  0,390 mm → 0,490 mm  1,10 mm $\frac{\pm}{\pm}$ 84 Ø L 1 ⊗ 735.490 059 103 383 ET  0,490 mm → 0,540 mm  1,15 mm $\frac{\pm}{\pm}$ 84 Ø L 2 ⊗ 735.500 059 103 383 FA  0,540 mm → 0,650 mm  1,20 mm $\frac{\pm}{\pm}$ 84 Ø L 3 ⊗ 735.400 059 103 383 EP  0,390 mm → 0,490 mm  1,10 mm $\frac{\pm}{\pm}$ 84 Ø R 1 ⊗ 735.430 059 103 383 EQ  0,490 mm → 0,540 mm  1,15 mm $\frac{\pm}{\pm}$ 84 Ø R 2 ⊗ 735.450 059 103 383 ER  0,540 mm → 0,650 mm  1,20 mm $\frac{\pm}{\pm}$ 84 Ø R 3 ⊗	ZKS 130.110 057 103 384 A (8x) M 12x1,5x159 2x 	554.970 059 103 483 M Cyl. 4-6  554.980 059 103 483 N Cyl. 1-3 

			<p>a) </p> <p>b) </p>	<p>K: </p> <p>N: </p>	
<p>VAS 235.650 FPM 724.590 036 109 675 A FPM 24x</p>	<p>724.250 06E 253 039 C 2x </p>	<p>232.910 06E 198 717 6x </p>	<p>a) 030.793 Dirko HT</p> <p>b) 982.340 N 016 027 6 incl. 813.036 M 14x1,5x12</p> <p>b) 591.840 N 013 815,8 Metal C 14x20x2</p> <p>b) 813.036 N 013 815,6 CU C 14x20x2</p>	<p>K:← 728.550 06E 103 153 E SP RD PTFE 45x60</p> <p>K:→ 026.790 079 103 051 F ASW LD PTFE/FPM 85x105x8,8</p>	
<p>VAS 235.650 FPM 724.590 036 109 675 A FPM 24x</p>	<p>148.271 059 253 039 E 2x </p>	<p>574.120 059 129 717 J 2x </p>	<p>a) 030.793 Dirko HT</p> <p>b) 982.340 N 016 027 6 incl. 813.036 M 14x1,5x12</p> <p>b) 591.840 N 013 815,8 Metal C 14x20x2</p> <p>b) 813.036 N 013 815,6 CU C 14x20x2</p>	<p>K:← 263.600 079 103 051 D ASW RD PTFE/ACM 55x70x8</p> <p>K:→ 026.790 079 103 051 F ASW LD PTFE/FPM 85x105x8,8</p> <p>N:← 325.155 068 103 085 E ASW WD FPM/ACM 32x47x10</p>	

AUDI (FAW)

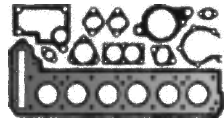

**ATX
BBG**

6 Cyl. **2771 ccm**
Cyl. 82,5 Ø

A6
09/2000 → 07/2005

ES **470.650**
2x
CS* **539.200**
SZ **863.590**
058 198 217
2x



632.565
078 103 383 R
1,20 mm ± 83,5 Ø
2x



ZKS **130.850**
078 103 385 K (8x)
M 11x1,5x133
2x



ZKHS **040.050**
078 198 025
2x



413.830
078 103 484 C
2x

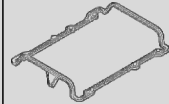

413.860
078 103 483 M
2x



BDX

6 Cyl. **2773 ccm**
Cyl. 84,5 Ø

A6L
11/2007 → 12/2008

ES⊕ **284.890**
CS* **244.710**

725.160
06E 103 149 M
86 Ø
Cyl. 4-6



725.190
06E 103 148 M
86 Ø
Cyl. 1-3



ZKS **325.040**
06E 103 385 E (8x)
M 10x1,5x172
2x



461.682
EL-Liq 74
↓

429.910
06E 103 483 Q
Cyl. 4-6

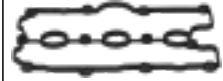

429.980
06E 103 484 P
Cyl. 1-3

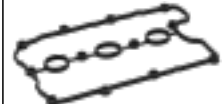

**CCE
CCEA**

6 Cyl. **2773 ccm**
Cyl. 84,5 Ø

A6L
01/2008 → 12/2012

ES⊕ **284.890**

725.160
06E 103 149 M
86 Ø
Cyl. 4-6



725.190
06E 103 148 M
86 Ø
Cyl. 1-3



ZKS **325.040**
06E 103 385 E (8x)
M 10x1,5x172
2x



461.682
EL-Liq 74
↓



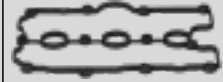



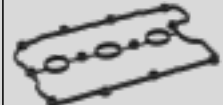







429.910
06E 103 483 Q
Cyl. 4-6











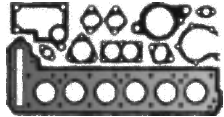
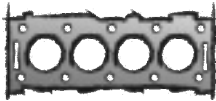

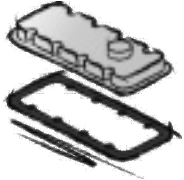



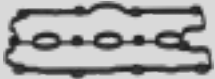
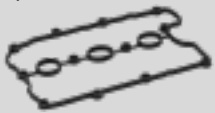
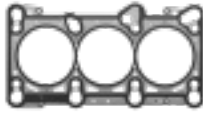

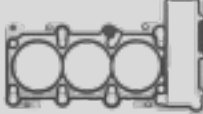

429.980
06E 103 484 P
Cyl. 1-3

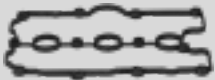
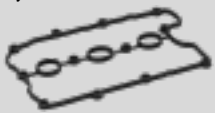

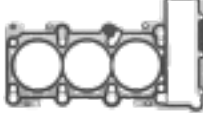















AUDI (FAW)

			<p>a) </p> <p>b) </p>	<p>K: </p> <p>N: </p>	
<p>VAS 057.070 FPM 724.590 036 109 675 A FPM 30x</p>	<p>433.250 078 253 039 G 2x </p>	<p>413.900 078 129 717 J 2x </p>	<p>a) 030.793 Dirko HT a) 467.762 078 103 610 E </p> <p>b) 567.640 N 908 132 01 M 14x1,5x22</p>	<p>K:← 155.560 038 103 085 E ASW RD PTFE/ACM 35x48x10 K:→ 728.880 078 103 051 G 070 103 051 A AW/BS LD PTFE/ACM 85x105x12 N:← 129.780 038 103 085 C ASW RD PTFE/ACM 32x47x10 3x N:← 325.155 068 103 085 E ASW WD FPM/ACM 32x47x10 4x N:→ 326.470 028 103 086 A ASW LD PTFE/ACM 32x47x10 1x N:→ 798.040 028 103 086 C ASW OF LD FPM 32x47x10 1x</p>	
<p>VAS 235.650 FPM 724.590 036 109 675 A FPM 24x</p>	<p>724.250 06E 253 039 C 2x </p>	<p>232.910 06E 198 717 6x </p>	<p>a) 030.793 Dirko HT b) 982.340 N 016 027 6 incl. 813.036 M 14x1,5x12 b) 591.840 N 013 815.8 Metal C 14x20x2 b) 813.036 N 013 815.6 CU C 14x20x2</p>	<p>K:← 728.550 06E 103 153 E SP RD PTFE 45x60 K:→ 026.790 079 103 051 F ASW LD PTFE/FPM 85x105x8,8</p>	
<p>VAS 235.650 FPM 724.590 036 109 675 A FPM 24x</p>	<p>724.250 06E 253 039 C 2x </p>	<p>232.910 06E 198 717 6x </p>	<p>a) 030.793 Dirko HT b) 982.340 N 016 027 6 incl. 813.036 M 14x1,5x12 b) 591.840 N 013 815.8 Metal C 14x20x2 b) 813.036 N 013 815.6 CU C 14x20x2</p>	<p>K:← 728.550 06E 103 153 E SP RD PTFE 45x60 K:→ 026.790 079 103 051 F ASW LD PTFE/FPM 85x105x8,8</p>	

AUDI (FAW)					
					
CNY CNYA CNYB 6 Cyl. 2773 ccm Cyl. 84,5 Ø A6L 01/2012 → 12/2016	ES⊕ 284.890 CS* 783.930	725.160 06E 103 149 M 86 Ø Cyl. 4-6 725.190 06E 103 148 M 86 Ø Cyl. 1-3	 	ZKS 223.890 WHT 005 739 (8x) M 10x1,5x170 2x 	461.682 EL-Liq 74 ↓ 429.910 06E 103 483 Q Cyl. 4-6  429.980 06E 103 484 P Cyl. 1-3 
BBJ 6 Cyl. 2976 ccm Cyl. 82,5 Ø A4 02/2003 → 09/2008 A6L 03/2005 → 12/2006	ES⊕ 430.181 2x	627.651 06C 103 383 H 0,90 mm $\frac{+}{-}$ 83 Ø 2x 	ZKS 057.450 06B 103 385 (8x) M 12x1,5x132 2x 	493.460 06C 103 483 J 2x 	
CAJ CAJA 6 Cyl. 2995 ccm Cyl. 84,5 Ø A6L 09/2008 → 12/2012	ES⊕ 340.590	323.330 06E 103 148 AG 85,2 Ø Cyl. 1-3 323.370 06E 103 149 AG 85,2 Ø Cyl. 4-6  	ZKS 325.040 06E 103 385 E (8x) M 10x1,5x172 2x 	461.682 EL-Liq 74 ↓ 429.910 06E 103 483 Q Cyl. 4-6  429.980 06E 103 484 P Cyl. 1-3 	
CHM CHMA CHMB CTT CTTA 6 Cyl. 2995 ccm Cyl. 84,5 Ø A4L 08/2012 → 12/2016 A6L 01/2012 → 12/2016	ES⊕ 340.590 CS* 783.930	323.330 06E 103 148 AG 85,2 Ø Cyl. 1-3 323.370 06E 103 149 AG 85,2 Ø Cyl. 4-6  	ZKS 223.890 WHT 005 739 (8x) M 10x1,5x170 2x 	461.682 EL-Liq 74 ↓ 429.910 06E 103 483 Q Cyl. 4-6  429.980 06E 103 484 P Cyl. 1-3 	

AUDI (FAW)

			<p>a) </p> <p>b) </p>	<p>K: </p> <p>N: </p>	
<p>VAS 235.650 FPM 724.590 036 109 675 A FPM 24x</p>	<p>724.250 06E 253 039 C 2x </p>	<p>232.910 06E 198 717 6x </p>	<p>a) 030.793 Dirko HT</p> <p>b) 982.340 N 016 027 6 incl. 813.036 M 14x1,5x12</p> <p>b) 591.840 N 013 815.8 Metal C 14x20x2</p> <p>b) 813.036 N 013 815.6 CU C 14x20x2</p>	<p>K:← 728.550 06E 103 153 E SP RD PTFE 45x60</p> <p>K:→ 026.790 079 103 051 F ASW LD PTFE/FPM 85x105x8,8</p>	
<p>VAS 057.070 FPM 724.590 036 109 675 A FPM 30x</p>	<p>433.250 078 253 039 G 2x </p>	<p>413.900 078 129 717 J 2x </p>	<p>a) 030.793 Dirko HT</p> <p>b) 567.640 N 908 132 01 M 14x1,5x22</p>	<p>K:← 155.560 038 103 085 E ASW RD PTFE/ACM 35x48x10</p> <p>N:← 655.340 06C 103 085 AW/BS RD PTFE/ACM 42x55x7 4x</p>	
<p>VAS 235.650 FPM 724.590 036 109 675 A FPM 24x</p>	<p>724.250 06E 253 039 C 2x </p>	<p>225.170 079 129 717 B 6x </p>	<p>a) 030.793 Dirko HT</p> <p>b) 982.340 N 016 027 6 incl. 813.036 M 14x1,5x12</p> <p>b) 591.840 N 013 815.8 Metal C 14x20x2</p> <p>b) 813.036 N 013 815.6 CU C 14x20x2</p>	<p>K:← 728.550 06E 103 153 E SP RD PTFE 45x60</p> <p>K:→ 026.790 079 103 051 F ASW LD PTFE/FPM 85x105x8,8</p>	<p>TLS 796.460</p>
<p>VAS 235.650 FPM 724.590 036 109 675 A FPM 24x</p>	<p>724.250 06E 253 039 C 2x </p>	<p>225.170 079 129 717 B 6x </p>	<p>a) 030.793 Dirko HT</p> <p>b) 982.340 N 016 027 6 incl. 813.036 M 14x1,5x12</p> <p>b) 591.840 N 013 815.8 Metal C 14x20x2</p> <p>b) 813.036 N 013 815.6 CU C 14x20x2</p>	<p>K:← 728.550 06E 103 153 E SP RD PTFE 45x60</p> <p>K:→ 026.790 079 103 051 F ASW LD PTFE/FPM 85x105x8,8</p>	<p>TLS 796.460</p>

AUDI (FAW)

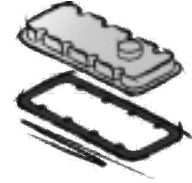
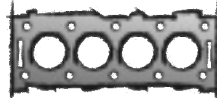
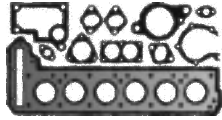

CREC

6 Cyl. **2995 ccm**
Cyl. 84,5 Ø

A6L

01/2016 → 12/2018

796.160

06E 103 148 AR
0,85 mm \pm 85,2 Ø
Cyl. 1-3



796.170

06E 103 149 AR
0,85 mm \pm 85,2 Ø
Cyl. 4-6

ZKS 223.890
WHT 005 739 (8x)
M 10x1,5x170
2x



461.682
EL-Liq 74
↓

429.910
06E 103 483 Q
Cyl. 4-6



429.980
06E 103 484 P
Cyl. 1-3

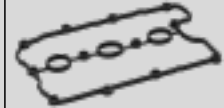

CTDB

6 Cyl. **2995 ccm**
Cyl. 84,5 Ø

A6L

01/2016 → 12/2018

796.160

06E 103 148 AR
0,85 mm \pm 85,2 Ø
Cyl. 1-3



796.170

06E 103 149 AR
0,85 mm \pm 85,2 Ø
Cyl. 4-6

ZKS 223.890
WHT 005 739 (8x)
M 10x1,5x170
2x



461.682
EL-Liq 74
↓

429.910
06E 103 483 Q
Cyl. 4-6



429.980
06E 103 484 P
Cyl. 1-3



DLZA

6 Cyl. **2995 ccm**
Cyl. 84,5 Ø

A6L

01/2019 →

ZKS 223.890
WHT 005 739 (8x)
M 10x1,5x170
2x







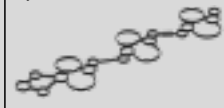



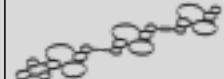



461.682
EL-Liq 74
↓











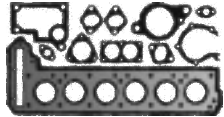
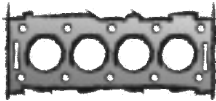

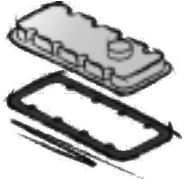

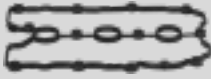
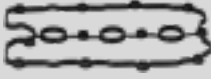



938.250
06M 103 650 D
Cyl. 1-3



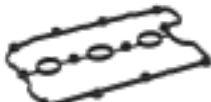











938.240
06M 103 649 D
Cyl. 4-6









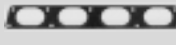

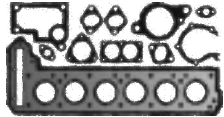
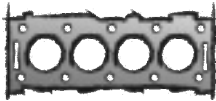

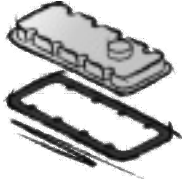



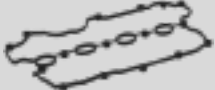





			<p>a) </p> <p>b) </p>	<p>K: </p> <p>N: </p>	
<p>VAS 235.650 FPM 724.590 036 109 675 A FPM 24x</p>	<p>724.250 06E 253 039 C 2x </p>	<p>858.060 6x</p>	<p>a) 030.793 Dirko HT</p> <p>b) 858.050 M 14x1,5x15</p> <p>b) 982.340 N 016 027 6 incl. 813.036 M 14x1,5x12</p> <p>b) 591.840 N 013 815.8 Metal C 14x20x2</p> <p>b) 813.036 N 013 815.6 CU C 14x20x2</p>	<p>K:← 728.550 06E 103 153 E SP RD PTFE 45x60</p> <p>K:→ 026.790 079 103 051 F ASW LD PTFE/FPM 85x105x8,8</p>	
<p>VAS 235.650 FPM 724.590 036 109 675 A FPM 24x</p>	<p>724.250 06E 253 039 C 2x </p>	<p>858.060 6x</p>	<p>a) 030.793 Dirko HT</p> <p>b) 858.050 M 14x1,5x15</p> <p>b) 591.840 N 013 815.8 Metal C 14x20x2</p> <p>b) 813.036 N 013 815.6 CU C 14x20x2</p>	<p>K:← 728.550 06E 103 153 E SP RD PTFE 45x60</p> <p>K:→ 026.790 079 103 051 F ASW LD PTFE/FPM 85x105x8,8</p>	
<p>VAS 562.250 FPM A 724.590 036 109 675 A FPM E 12x</p>		<p>928.300 06M 133 198 B 2x </p>	<p>a) 030.793 Dirko HT</p> <p>b) 858.050 M 14x1,5x15</p> <p>b) 243.205 N 013 849.3 AL A 14x20x1,5</p> <p>b) 591.840 N 013 815.8 Metal C 14x20x2</p>	<p>K:← 263.600 079 103 051 D ASW RD PTFE/ACM 55x70x8</p> <p>K:→ 026.790 079 103 051 F ASW LD PTFE/FPM 85x105x8,8</p>	

AUDI (FAW) 				
AUK 6 Cyl. 3123 ccm Cyl. 84,5 Ø A6L 09/2005 → 12/2008	ES⊕ 244.650 CS* 244.710	725.160 06E 103 149 M 86 Ø Cyl. 4-6 725.190 06E 103 148 M 86 Ø Cyl. 1-3	ZKS 325.040 06E 103 385 E (8x) M 10x1,5x172 2x 	461.682 EL-Liq 74 ↓ 725.860 06E 103 483 G Cyl. 4-6  725.870 06E 103 484 G Cyl. 1-3  720.220 06E 103 649 E ↓ Cyl. 1-3  720.230 06E 103 650 A ↓ Cyl. 4-6 
CAL CALA 6 Cyl. 3197 ccm Cyl. 85,5 Ø A4L 01/2009 → 12/2011	ES⊕ 284.300 CS* 245.690	717.400 06E 103 148 AC 86,2 Ø Cyl. 1-3 Cyl. 1-3  717.380 06E 103 149 AC 86,2 Ø Cyl. 4-6 Cyl. 4-6 	ZKS 325.040 06E 103 385 E (8x) M 10x1,5x172 →07/2011 2x  ZKS 223.890 WHT 005 739 (8x) M 10x1,5x170 07/2011→ 2x 	461.682 EL-Liq 74 ↓ 429.910 06E 103 483 Q Cyl. 4-6  429.980 06E 103 484 P Cyl. 1-3 
BAT 8 Cyl. 4163 ccm Cyl. 84,5 Ø A6L 09/2005 → 12/2006		278.940 079 103 383 BB 86 Ø L  278.930 079 103 383 BA 86 Ø R 	ZKS 215.000 077 103 385 D (10x) M 10x1,5x115 2x 	473.670 079 103 650 C L  473.660 079 103 649 C R 

AUDI (FAW)

			<p>a) </p> <p>b) </p>	<p>K: </p> <p>N: </p>	
<p>VAS 235.650 FPM 724.590 036 109 675 A FPM 24x</p>	<p>724.250 06E 253 039 C 2x </p>	<p>232.910 06E 198 717 6x </p>	<p>a) 030.793 Dirko HT</p> <p>b) 567.640 N 908 132 01 M 14x1,5x22</p> <p>b) 982.340 N 016 027 6 incl. 813.036 M 14x1,5x12</p> <p>b) 591.840 N 013 815.8 Metal C 14x20x2</p> <p>b) 813.036 N 013 815.6 CU C 14x20x2</p>	<p>K:← 728.550 06E 103 153 E SP RD PTFE 45x60</p> <p>K:→ 026.790 079 103 051 F ASW LD PTFE/FPM 85x105x8,8</p>	
<p>VAS 235.650 FPM 724.590 036 109 675 A FPM 24x</p>	<p>724.250 06E 253 039 C 2x </p>	<p>232.910 06E 198 717 6x </p>	<p>a) 030.793 Dirko HT</p> <p>b) 982.340 N 016 027 6 incl. 813.036 M 14x1,5x12</p> <p>b) 591.840 N 013 815.8 Metal C 14x20x2</p> <p>b) 813.036 N 013 815.6 CU C 14x20x2</p>	<p>K:← 728.550 06E 103 153 E SP RD PTFE 45x60</p> <p>K:→ 026.790 079 103 051 F ASW LD PTFE/FPM 85x105x8,8</p>	
<p>VAS 235.620 FPM 2x 724.590 036 109 675 A FPM 40x</p>	<p>530.930 077 253 039 C 2x </p>	<p>530.982 077 129 717 Q 2x </p>	<p>a) 030.793 Dirko HT</p> <p>b) 878.100 M 24x1,5x10</p> <p>b) 812.773 N 013 850.3 FE C 24x32x2,5</p> <p>b) 813.168 CU C 24x32x2,5</p>	<p>K:← 173.890 079 103 051 G ASW RD PTFE/ACM 55x72x8</p> <p>K:→ 026.790 079 103 051 F ASW LD PTFE/FPM 85x105x8,8</p>	

AUDI (FAW) 				
BVJ 8 Cyl. 4163 ccm Cyl. 84,5 Ø A6L 11/2006 → 10/2008	ES⊕ 520.720 A6 4F2/4F5 →07/2008 A8 4E2/4E8 →11/2008 ES⊕ 520.780 A6 4F2/4F5 07/2008→ A8 4E2/4E8 11/2008→	174.030 079 103 383 AR L  174.020 079 103 383 AQ R 	ZKS 341.400 WHT 001 017 (8x) M10x1,5x113 2x 	473.670 079 103 650 C L  898.610 079 103 483 T L A6 4F2/4F5 4F-8-045 001→ A8 4E2/4E8  473.660 079 103 649 C R  898.620 079 103 484 C R 

			<p>a) </p> <p>b) </p>	<p>K: </p> <p>N: </p>	
<p>VAS 235.610 FPM 2x</p> <p>724.590 036 109 675 A FPM 32x</p>	<p>130.130 079 253 039 F 2x</p> 	<p>473.650 079 133 074 B 2x</p> <hr/> <p>A6 4F2/4F5 →07/2008</p> <hr/> <p>A8 4E2/4E8 →11/2008</p>  <p>225.170 079 129 717 B 07/2008→ 8x</p> 	<p>a) 030.793 Dirko HT</p> <p>b) 982.340 N 016 027 6 incl. 813.036 M 14x1,5x12</p> <p>b) 591.840 N 013 815.8 Metal C 14x20x2</p> <p>b) 813.036 N 013 815.6 CU C 14x20x2</p>	<p>K:← 173.890 079 103 051 G ASW RD PTFE/ACM 55x72x8</p> <p>K:→ 026.790 079 103 051 F ASW LD PTFE/FPM 85x105x8,8</p>	



BMW	ccm	kW	→	→		
114 d (F20/21)	3	1496	70	06/2015		B37 D15 A 408
114 d (F20/21)	4	1598	70	07/2012		N47 D16 A 420
114 i (F20/21)	4	1598	75	12/2011		N13 B16 A 418
116 d (E81/87)	4	1995	85	11/2008	12/2011	N47 D20 A 448 N47 D20 C 452
116 d (E81/87)	4	1995	66	01/2011	12/2011	N47 D20 A 448 N47 D20 C 452
116 d (F20/21)	3	1496	85	03/2015		B37 D15 A 408
116 d (F20/21)	4	1598	85	12/2011		N47 D16 A 420
116 d (F20/21)	4	1995	85	07/2011		N47 D20 C 452
116 d (F40)	3	1496	85	07/2019		B37 C15 A 408
116 i (E81/87)	4	1596	85	06/2004	12/2011	N45 B16 A 418
116 i (E81/87)	4	1599	90	03/2007	12/2011	N43 B16 AA 420
116 i (E81/87)	4	1995	90	11/2008	12/2011	N43 B20 A 444
116 i (F20/21)	3	1499	80	03/2015		B38 B15 A 412
116 i (F20/21)	4	1598	100	07/2011		N13 B16 A 418
116 i (F40)	3	1499	80	11/2020		B38 A15 A 410
118 d (E81/82/87/88)	4	1995	90	06/2004	02/2007	M47 D20 (204D4) 444
118 d (E81/82/87/88)	4	1995	100	09/2006	12/2013	N47 D20 A 448 N47 D20 C 452
118 d (E81/82/87/88)	4	1995	105	09/2006	12/2013	N47 D20 A 448 N47 D20 C 452
118 d (F20/21)	4	1995	100	07/2011	06/2019	B47 D20 A 440 N47 D20 C 452
118 d (F20/21)	4	1995	105	07/2011		N47 D20 C 452
118 d (F20/21)	4	1995	110	03/2015		B47 D20 A 440
118 d (F40)	4	1995	100	07/2019		B47 C20 B 438
118 d (F40)	4	1995	110	07/2019		B47 C20 B 438
118 i (E81/82/87/88)	4	1995	95	07/2004	02/2008	N46 B20 B 446
118 i (E81/82/87/88)	4	1995	100	09/2006	12/2013	N46 B20 B 446
118 i (E81/82/87/88)	4	1995	105	09/2006	12/2013	N43 B20 A 444
118 i (E81/82/87/88)	4	1995	125	03/2007	12/2007	N43 B20 A 444
118 i (F20/21)	3	1499	100	03/2015		B38 B15 A 412
118 i (F20/21)	4	1598	125	07/2011		N13 B16 A 418
118 i (F20/21)	4	1598	100	03/2015		N13 B16 A 418
118 i (F40)	3	1499	103	07/2019		B38 A15 A 410
118 i (F40)	3	1499	100	11/2020		B38 A15 A 410
118 i (F52)	3	1499	100	01/2017	08/2019	B38 A15 C 410

BMW	ccm	kW	→	→		
120 d (E81/82/87/88)	4	1995	110	06/2004	02/2007	M47 D20 (204D4) 444
120 d (E81/82/87/88)	4	1995	120	06/2004	12/2013	M47 D20 (204D4) 444 N47 D20 A 448 N47 D20 C 452
120 d (E81/82/87/88)	4	1995	115	05/2006	02/2007	M47 D20 (204D4) 444
120 d (E81/82/87/88)	4	1995	125	03/2007	10/2010	N47 D20 A 448
120 d (E81/82/87/88)	4	1995	130	03/2007	12/2013	N47 D20 A 448 N47 D20 C 452
120 d (E81/82/87/88)	4	1995	145	03/2007	12/2013	N47 D20 A 448 N47 D20 C 452
120 d (F20/21)	4	1995	120	07/2011		B47 D20 A 440 N47 D20 C 452
120 d (F20/21)	4	1995	135	07/2011		N47 D20 C 452
120 d (F20/21)	4	1995	147	07/2011		N47 D20 C 452
120 d (F20/21)	4	1995	140	03/2015		B47 D20 A 440
120 d (F40)	4	1995	140	07/2019		B47 C20 B 438
120 i (E81/82/87/88)	4	1995	110	06/2004	02/2007	N46 B20 B 446 N46 B20 BD 448 N46 B20 C 446 N46 B20 CC 446
120 i (E81/82/87/88)	4	1995	115	03/2007	12/2013	N46 B20 A 446 N46 B20 B 448 N46 B20 BD 448 N46 B20 C 446 N46 B20 CC 446 N46 B20 E 446
120 i (E81/82/87/88)	4	1995	120	03/2007	12/2013	N43 B20 A 444
120 i (E81/82/87/88)	4	1995	125	03/2007	10/2013	N43 B20 A 444
120 i (F20/21)	4	1598	130	03/2015		N13 B16 A 418
120 i (F20/21)	4	1997	135	03/2015	06/2016	N20 B20 A 456
120 i (F20/21)	4	1998	135	07/2016		B48 B20 A 466
120 i (F40)	4	1998	131	11/2020		B48 A20 A 462
120 i (F40)	4	1998	141	03/2021		B46 A20 B 460
120 i (F52)	4	1998	141	06/2018		B48 A20 C 464
123 d (E81/82/87/88)	4	1995	150	03/2007	12/2013	N47 D20 B 450 N47 D20 D 454
125 d (F20/21)	4	1995	155	12/2011	06/2019	B47 D20 B 442 N47 D20 D 454
125 d (F20/21)	4	1995	160	12/2011		N47 D20 D 454
125 d (F20/21)	4	1995	165	03/2015		B47 D20 B 442
125 i (E81/82/87/88)	6	2996	160	12/2007	10/2013	N52 B30 A 520 N52 B30 B 522 N52 B30 BF 522
125 i (F20/21)	4	1997	160	12/2011		N20 B20 A 456



BMW		ccm	kW	→	→		
125 i (F20/21)	4	1997	175	03/2012		N20 B20 A	456
125 i (F20/21)	4	1998	165	10/2015		B48 B20 B	468
128 i (E81/82/87/88)	6	2996	172	10/2007	10/2013	N51 B30 A N52 B30 A	518 520
128 ti (F40)	4	1998	180	11/2020		B48 A20 B	464
130 i (E81/87)	6	2996	195	09/2005	12/2011	N52 B30 A N52 B30 AF N52 B30 B N52 B30 BF	520 522
130 i (E81/87)	6	2996	190	09/2006	12/2011	N52 B30 A N52 B30 AF N52 B30 B N52 B30 BF	520 522
135 i (E82/88)	6	2979	225	10/2007	10/2013	N54 B30 A N55 B30 A	498 500
135 i (E82/88)	6	2979	240	10/2007	12/2013	N54 B30 A N55 B30 A	498 500
2.5 CS (E9)	6	2494	110	09/1974	03/1976	M30 B25	474
214 d (F45/46)	3	1496	70	07/2014	02/2018	B37 C15 A	408
216 d (F44)	3	1496	85	03/2020		B37 C15 A	408
216 d (F45/46)	3	1496	85	03/2014		B37 C15 A	408
216 i (F45/46)	3	1499	75	09/2014	02/2018	B38 A15 A	410
216 i (F45/46)	3	1499	80	03/2018		B38 A15 A	410
218 d (F22/23)	4	1995	100	03/2014		B47 D20 A N47 D20 C	440 452
218 d (F22/23)	4	1995	105	03/2014	06/2015	N47 D20 C	452
218 d (F22/23)	4	1995	110	07/2015		B47 D20 A	440
218 d (F44)	4	1995	100	11/2019		B47 C20 B	438
218 d (F44)	4	1995	110	07/2020		B47 C20 B	438
218 d (F45/46)	4	1995	100	11/2013		B47 C20 A B47 C20 B	436 438
218 d (F45/46)	4	1995	110	11/2013		B47 C20 A B47 C20 B	436 438
218d (U06)	4	1995	110	11/2021		B47 C20 B	438
218 i (F22/23)	3	1499	100	03/2015		B38 B15 A	412
218 i (F44)	3	1499	103	11/2019		B38 A15 A	410
218 i (F44)	3	1499	100	11/2020		B38 A15 A	410
218 i (F45/46)	3	1499	100	07/2014	02/2018	B38 A15 A	410
218 i (F45/46)	3	1499	103	04/2017		B38 A15 A	410
220 d (F22/23)	4	1995	135	10/2012	11/2014	N47 D20 C	452
220 d (F22/23)	4	1995	147	10/2012	11/2014	N47 D20 C	452
220 d (F22/23)	4	1995	120	03/2014		B47 D20 A N47 D20 C	440 452

BMW		ccm	kW	→	→		
220 d (F22/23)	4	1995	140	03/2014		B47 D20 A	440
220 d (F44)	4	1995	120	11/2019		B47 C20 B	438
220 d (F44)	4	1995	140	11/2019		B47 C20 B	438
220 d (F45/46)	4	1995	120	03/2014		B47 C20 A B47 C20 B	436 438
220 d (F45/46)	4	1995	140	03/2014		B47 C20 A B47 C20 B	436 438
220 d (G42)	4	1995	140	08/2021		B47 D20 B	442
220 i (F22/23)	3	1499	100	10/2017		B38 B15 A	412
220 i (F22/23)	4	1997	135	10/2013		N20 B20 A N20 B20 B	456
220 i (F22/23)	4	1998	135	09/2015		B48 B20 A	466
220 i (F44)	4	1998	141	07/2020		B48 A20 A B48 A20 C	462 464
220 i (F44)	4	1998	131	11/2020		B48 A20 A	462
220 i (F45/46)	4	1998	120	03/2014		B48 A20 A	462
220 i (F45/46)	4	1998	141	03/2014		B48 A20 A B48 A20 B	462 464
220 i (F45/46)	4	1998	131	11/2020		B48 A20 A	462
220 i (F45/46)	4	1998	131	11/2020		B48 A20 A	462
220 i (G42)	4	1998	135	08/2021		B48 B20 A	466
225 d (F22/23)	4	1995	160	01/2014		N47 D20 D	454
225 d (F22/23)	4	1995	165	07/2015		B47 D20 B	442
225 i (F22/23)	4	1998	135	10/2017		B48 B20 A	466
225 i (F45/46)	4	1998	170	11/2013		B48 A20 B	464
225 xe (F45/46)	3	1499	100	11/2014		B38 A15 A	410
225 xe (F45/46)	3	1499	165	11/2014		B38 A15 A	410
225 xe (F45/46)	3	1499	92	11/2020		B38 A15 A	410
225 xe (F45/46)	3	1499	162	11/2020		B38 A15 A	410
228 i (F22/23)	4	1997	179	01/2014		N20 B20 A	456
228 i (F22/23)	4	1997	180	07/2014		N20 B20 A N26 B20 A	456 458
228 i (F44)	4	1998	170	11/2019		B46 A20 B	460
230 i (F22/23)	4	1998	185	07/2016		B46 B20 B B48 B20 B	462 468
230 i (G42)	4	1998	190	08/2021		B48 B20 B	468
2500 (E3)	6	2494	110	10/1968	04/1977	M30 B25	474
3.0 M (E82/88)	6	2979	250	03/2011	06/2012	N54 B30 A	498
316 (E46)	4	1596	77	06/2002	02/2005	N40 B16 A	416
316 Ci (E46)	4	1596	77	04/2000	07/2006	M43 B16 (164E3)	416



BMW	ccm	kW	→	→	→	→
316 Ci (E46)	4	1596	85	06/2002	07/2006	N45 B16 A 418
316 d (E90/91)	4	1995	85	07/2009	06/2012	N47 D20 C 452
316 d (F30/31/35)	4	1995	85	03/2012	06/2019	B47 D20 A 440 N47 D20 C 452
316 d (G20/21)	4	1995	90	03/2020		B47 D20 B 442
316 d (G20/21)	4	1995	85	11/2020		B47 D20 B 442
316 g (E36)	4	1596	75	02/1996	08/2000	M43 B16 (164E2) 416
316 i (E30)	4	1596	73	09/1987	06/1994	M40 B16 (164E1) 414
316 i (E30)	4	1596	75	07/1988	06/1994	M40 B16 (164E1) 414
316 i (E30)	4	1766	75	08/1987	08/1988	M10 B18 (184KA) 422
316 i (E36)	4	1596	73	03/1991	08/1993	M40 B16 (164E1) 414
316 i (E36)	4	1596	75	09/1993	08/2000	M43 B16 (164E2) 416
316 i (E36)	4	1895	77	01/1999	08/2000	M43 B19 (194E1) 428
316 i (E46)	4	1596	77	04/2000	02/2005	M43 B16 (164E3) 416
316 i (E46)	4	1596	85	06/2002	02/2005	N40 B16 A 416 N45 B16 A 418
316 i (E46)	4	1796	85	02/2002	02/2005	N42 B18 A 428 N46 B18 A
316 i (E46)	4	1895	77	12/1998	02/2002	M43 B19 (194E1) 428
316 i (E90/91/92/93)	4	1596	85	09/2005	10/2011	N45 B16 A 418 N45 B16 AC
316 i (E90/91/92/93)	4	1599	90	09/2007	06/2013	N43 B16 A 420 N43 B16 AA
316 i (F30/31/35)	4	1598	100	07/2012	08/2016	N13 B16 A 418
316 ti (E46)	4	1596	85	06/2002	02/2005	N40 B16 A 416 N45 B16 A 418
316 ti (E46)	4	1796	85	06/2001	02/2005	N42 B18 A 428 N46 B18 A
318 (E21)	4	1766	72	08/1975	08/1980	M10 B18 (184VA) 424
318 Ci (E46)	4	1895	85	12/1999	08/2001	M43 B19 (194E1) 428
318 Ci (E46)	4	1895	87	12/1999	08/2001	M43 B19 (194E1) 428
318 Ci (E46)	4	1995	100	12/2000	08/2006	N42 B20 A 444 N46 B20 A 446
318 Ci (E46)	4	1995	105	09/2001	12/2007	N42 B20 A 444 N46 B20 A 446

BMW	ccm	kW	→	→	→	→
318 Ci (E46)	4	1995	110	03/2004	08/2006	N46 B20 A 446 N46 B20 B 448 N46 B20 C
318 d (E46)	4	1951	85	09/2001	03/2003	M47 D20 (204D1) 430
318 d (E46)	4	1995	85	03/2003	02/2005	M47 D20 (204D4) 444
318 d (E90/91)	4	1995	90	03/2005	08/2007	M47 D20 (204D4) 444
318 d (E90/91)	4	1995	105	02/2007	06/2012	N47 D20 A 448 N47 D20 C 452
318 d (E90/91)	4	1995	100	07/2007	06/2012	N47 D20 A 448 N47 D20 C 452
318 d (F30/31/34/35)	4	1995	100	03/2012	06/2019	B47 D20 A 440 N47 D20 C 452
318 d (F30/31/34/35)	4	1995	105	03/2012	06/2015	N47 D20 C 452
318 d (F30/31/34/35)	4	1995	110	07/2015		B47 D20 A 440
318 d (G20/21)	4	1995	100	03/2019		B47 D20 B 442
318 d (G20/21)	4	1995	110	03/2019		B47 D20 B 442
318 i (E21)	4	1766	77	11/1979	08/1982	M10 B18 (184VA) 424
318 i (E30)	4	1766	77	09/1982	06/1990	M10 B18 (184EA) 422 M10 B18 (184EB) 424 M10 B18 (184EZ)
318 i (E30)	4	1766	75	12/1984	08/1988	M10 B18 (184KA) 422
318 i (E30)	4	1796	83	06/1987	06/1994	M40 B18 (184E1) 424
318 i (E30)	4	1796	85	09/1987	06/1991	M40 B18 (184E1) 424
318 i (E30)	4	1796	103	10/1990	12/1992	M42 B18 (184S1) 426
318 i (E36)	4	1796	83	09/1990	06/1994	M40 B18 (184E1) 424
318 i (E36)	4	1796	103	02/1992	12/1995	M42 B18 (184S1) 426
318 i (E36)	4	1796	85	09/1993	11/1999	M43 B18 (184E2) 426
318 i (E36)	4	1895	103	09/1995	09/1999	M44 B19 (194S1) 428
318 i (E46)	4	1895	87	12/1997	09/2001	M43 B19 (194E1) 428
318 i (E46)	4	1895	85	10/1999	09/2001	M43 B19 (194E1) 428
318 i (E46)	4	1995	100	09/2001	02/2005	N42 B20 A 444

**BMW**

BMW		ccm	kW	→	→		
318 i (E46)	4	1995	105	09/2001	07/2005	N42 B20 A N46 B20 A N46 B20 C	444 446 448
318 i (E90/91/92/93)	4	1995	95	09/2005	08/2007	N46 B20 B	446
318 i (E90/91/92/93)	4	1995	105	05/2007	12/2013	N43 B20 A	444
318 i (E90/91/92/93)	4	1995	100	09/2007	03/2012	N46 B20 B N46 B20 C N46 B20 CC N46 B20 CD N46 B20 E	446 448
318 i (F30/31/35)	3	1499	100	07/2015	06/2019	B38 B15 A	412
318 i (G20/21)	4	1998	115	03/2020		B48 B20 A	466
318 is (E30)	4	1796	100	09/1989	08/1991	M42 B18 (184S1)	426
318 is (E36)	4	1796	103	01/1992	12/1995	M42 B18 (184S1)	426
318 is (E36)	4	1895	103	01/1996	05/1998	M44 B19 (194S1)	428
318 td (E36)	4	1665	66	01/1995	08/2000	M41 D17 (174T1)	420
318 ti (E36)	4	1796	103	09/1994	12/1995	M42 B18 (184S1)	426
318 ti (E36)	4	1895	103	01/1996	08/1999	M44 B19 (194S1)	428
318 ti (E46)	4	1995	100	03/2001	12/2004	N42 B20 A N46 B20 A	444 446
318 ti (E46)	4	1995	105	03/2001	12/2004	N42 B20 A N46 B20 A	444 446
320/6 (E21)	6	1990	90	08/1977	10/1982	M20 B20 (206VA)	430
320 Cd (E46)	4	1995	110	11/2003	12/2007	M47 D20 (204D4)	444
320 Ci (E46)	6	1991	110	02/1999	08/2001	M52 B20 (206S4)	434
320 Ci (E46)	6	2171	120	01/2000	12/2007	M54 B22 (226S1)	470
320 Ci (E46)	6	2171	125	01/2000	12/2007	M54 B22 (226S1)	470
320 d (E46)	4	1951	95	02/1998	08/2001	M47 D20 (204D1)	430
320 d (E46)	4	1951	100	04/1998	12/2002	M47 D20 (204D1) M47 D20 (204D4)	430 444
320 d (E46)	4	1995	110	09/2001	05/2005	M47 D20 (204D4)	444
320 d (E90/91/92/93)	4	1995	110	12/2004	09/2007	M47 D20 (204D4)	444
320 d (E90/91/92/93)	4	1995	115	12/2004	09/2007	M47 D20 (204D4)	444

BMW		ccm	kW	→	→		
320 d (E90/91/92/93)	4	1995	120	12/2004	12/2013	M47 D20 (204D4) N47 D20 A N47 D20 C	444 448 452
320 d (E90/91/92/93)	4	1995	130	09/2006	12/2010	N47 D20 A N47 D20 C	448 452
320 d (E90/91/92/93)	4	1995	145	09/2006	02/2010	N47 D20 A N47 D20 C	448 452
320 d (E90/91/92/93)	4	1995	125	01/2007	12/2009	N47 D20 C	452
320 d (E90/91/92/93)	4	1995	135	03/2010	10/2013	N47 D20 C	452
320 d (E90/91/92/93)	4	1995	147	03/2010	10/2013	N47 D20 C	452
320 d (F30/31/34/35)	4	1995	120	11/2011	06/2019	B47 D20 A N47 D20 C	440 452
320 d (F30/31/34/35)	4	1995	135	11/2011	03/2016	N47 D20 C	452
320 d (F30/31/34/35)	4	1995	147	11/2011	03/2016	N47 D20 C	452
320 d (F30/31/34/35)	4	1995	140	07/2015		B47 D20 A	440
320 d (G20/21)	4	1995	120	11/2018		B47 D20 B	442
320 d (G20/21)	4	1995	140	11/2018		B47 D20 B	442
320 e (G20/21)	4	1998	120	07/2020		B48 B20 A	466
320 e (G20/21)	4	1998	150	07/2020		B48 B20 A	466
320 i (E21)	4	1766	74	09/1979	12/1983	M10 B18 (184EA)	422
320 i (E30)	6	1990	92	09/1982	12/1991	M20 B20 (206EB)	430
320 i (E30)	6	1990	95	05/1986	11/1993	M20 B20 (206KA)	430
320 i (E30)	6	1990	93	10/1986	10/1993	M20 B20 (206KA)	430
320 i (E30)	6	1991	95	10/1986	12/1991	M20 B20 (206KA)	430
320 i (E30)	6	1991	93	01/1988	12/1991	M20 B20 (206KA)	430
320 i (E36)	6	1991	110	01/1991	11/1999	M50 B20 (206S1) M50 B20 (206S2) M52 B20 (206S3)	432 434
320 i (E46)	6	1991	110	03/1998	09/2000	M52 B20 (206S4)	434
320 i (E46)	6	2171	120	09/2000	02/2005	M54 B22 (226S1)	470
320 i (E46)	6	2171	125	09/2000	02/2005	M54 B22 (226S1)	470
320 i (E90/91/92/93)	4	1995	110	12/2004	06/2012	N46 B20 B N46 B20 BD N46 B20 C N46 B20 CB	446 448

BMW

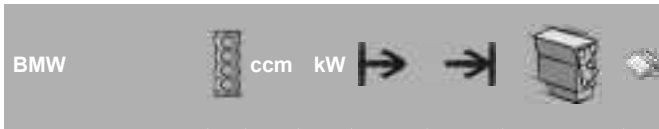

320 i (E90/91/92/93)	4	1995	115	09/2005	12/2013	N46 B20 B N46 B20 BD N46 B20 C N46 B20 CC N46 B20 CD N46 B20 E	446 448
-----------------------------	----------	------	-----	---------	---------	---	------------

320 i (E90/91/92/93)	4	1995	120	09/2006	12/2013	N43 B20 A	444
-----------------------------	----------	------	-----	---------	---------	-----------	-----

320 i (E90/91/92/93)	4	1995	125	02/2007	12/2013	N43 B20 A	444
-----------------------------	----------	------	-----	---------	---------	-----------	-----

320 i (E90/91/92/93)	4	1995	112	01/2010	12/2013	N46 B20 B N46 B20 CC N46 B20 CD N46 B20 E	446 448
-----------------------------	----------	------	-----	---------	---------	--	------------

320 i (F30/31/34/35)	4	1598	125	11/2012	06/2016	N13 B16 A	418
-----------------------------	----------	------	-----	---------	---------	-----------	-----

320 i (F30/31/34/35)	4	1997	134	03/2012	10/2018	N20 B20 A N20 B20 B	456
-----------------------------	----------	------	-----	---------	---------	------------------------	-----

320 i (F30/31/34/35)	4	1997	135	03/2012	10/2018	N20 B20 A N20 B20 B N20 B20 D	456
-----------------------------	----------	------	-----	---------	---------	-------------------------------------	-----

320 i (F30/31/34/35)	4	1997	120	11/2012	06/2016	N20 B20 A N20 B20 B	456
-----------------------------	----------	------	-----	---------	---------	------------------------	-----

320 i (F30/31/34/35)	4	1998	135	07/2015		B48 B20 A	466
-----------------------------	----------	------	-----	---------	--	-----------	-----

320 i (F30/31/34/35)	4	1998	120	07/2016		B48 B20 A	466
-----------------------------	----------	------	-----	---------	--	-----------	-----

320 i G20/21)	4	1597	125	03/2019		B48 B16 A	418
----------------------	----------	------	-----	---------	--	-----------	-----

320 i G20/21)	4	1998	135	03/2019		B46 B20 B B48 B20 A B48 B20 B	462 466 468
----------------------	----------	------	-----	---------	--	-------------------------------------	-------------------

320 is (E30)	4	1990	141	05/1988	12/1990	S14 B20 (204EA)	436
---------------------	----------	------	-----	---------	---------	--------------------	-----

320 si (E90/91)	4	1997	127	09/2005	08/2006	N45 B20 A	458
------------------------	----------	------	-----	---------	---------	-----------	-----

323 Ci (E46)	6	2494	120	04/1999	09/2000	M52 B25 (256S4)	484
---------------------	----------	------	-----	---------	---------	--------------------	-----

323 Ci (E46)	6	2494	125	04/1999	09/2000	M52 B25 (256S4)	484
---------------------	----------	------	-----	---------	---------	--------------------	-----

323 i (E21)	6	2316	105	01/1978	10/1982	M20 B23 (236EA)	472
--------------------	----------	------	-----	---------	---------	--------------------	-----

323 i (E30)	6	2316	102	09/1982	12/1985	M20 B23 (236EB)	472
--------------------	----------	------	-----	---------	---------	--------------------	-----

323 i (E30)	6	2316	110	09/1983	09/1986	M20 B23 (236EC) M20 B23 (236EW)	472
--------------------	----------	------	-----	---------	---------	--	-----

323 i (E36)	6	2494	125	05/1995	11/1999	M52 B25 (256S3)	480
--------------------	----------	------	-----	---------	---------	--------------------	-----

323 i (E46)	6	2494	120	03/1998	09/2000	M52 B25 (256S4)	484
--------------------	----------	------	-----	---------	---------	--------------------	-----

323 i (E46)	6	2494	125	03/1998	12/2000	M52 B25 (256S3) M52 B25 (256S4)	480 484
--------------------	----------	------	-----	---------	---------	--	------------

323 i (E46)	6	2494	127	04/1999	12/2000	M52 B25 (256S4)	484
--------------------	----------	------	-----	---------	---------	--------------------	-----

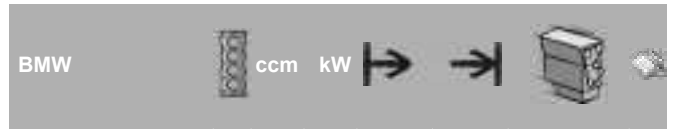

323 i (E90/91/92/93)	6	2497	130	09/2005	09/2011	N52 B25 A N52 B25 B N52 B25 BE N52 B25 BF	490
-----------------------------	----------	------	-----	---------	---------	--	-----

323 i (E90/91/92/93)	6	2497	140	04/2006	02/2012	N52 B25 A N52 B25 AE N52 B25 BE N52 B25 BF	490
-----------------------------	----------	------	-----	---------	---------	---	-----

323 ti (E36)	6	2494	125	09/1997	08/2000	M52 B25 (256S3)	480
---------------------	----------	------	-----	---------	---------	--------------------	-----

323 ti (E36)	6	2494	120	01/1999	08/2000	M52 B25 (256S3)	480
---------------------	----------	------	-----	---------	---------	--------------------	-----

324 d (E30)	6	2443	63	09/1985	12/1990	M21 D24 (246DA) M21 D24 (246DB)	472
--------------------	----------	------	----	---------	---------	--	-----

324 td (E30)	6	2443	85	09/1987	06/1993	M21 D24 (246TB)	474
---------------------	----------	------	----	---------	---------	--------------------	-----

325 Ci (E46)	6	2494	137	09/2000	12/2006	M54 B25 (256S5)	486
---------------------	----------	------	-----	---------	---------	--------------------	-----

325 Ci (E46)	6	2494	141	09/2000	08/2006	M54 B25 (256S5)	486
---------------------	----------	------	-----	---------	---------	--------------------	-----

325 d (E90/91/92/93)	6	2993	145	09/2006	06/2012	M57 D30 (306D3)	510
-----------------------------	----------	------	-----	---------	---------	--------------------	-----

325 d (E90/91/92/93)	6	2993	155	02/2007	12/2010	M57 D30 (306D3)	510
-----------------------------	----------	------	-----	---------	---------	--------------------	-----

325 d (E90/91/92/93)	6	2993	150	09/2009	12/2013	N57 D30 A	514
-----------------------------	----------	------	-----	---------	---------	-----------	-----

325 d (F30/31/34/35)	4	1995	155	03/2013	06/2016	N47 D20 D	454
-----------------------------	----------	------	-----	---------	---------	-----------	-----

325 d (F30/31/34/35)	4	1995	160	03/2013	06/2016	N47 D20 D	454
-----------------------------	----------	------	-----	---------	---------	-----------	-----

325 d (F30/31/34/35)	4	1995	165	03/2016	02/2018	B47 D20 B	442
-----------------------------	----------	------	-----	---------	---------	-----------	-----

325 e 2.7 (E30)	6	2693	90	10/1983	12/1988	M20 B27 (276KA) M20 B27 (276KB)	492
------------------------	----------	------	----	---------	---------	--	-----

325 e 2.7 (E30)	6	2693	95	01/1985	08/1987	M20 B27 (276KB)	492
------------------------	----------	------	----	---------	---------	--------------------	-----

325 i (E30)	6	2494	126	09/1983	11/1989	M20 B25 (256E1) M20 B25 (256E2) M20 B25 (256EX) M20 B25 (256K1)	474
--------------------	----------	------	-----	---------	---------	--	-----

325 i (E30)	6	2494	141	05/1984	01/1991	M20 B25 (256E2)	474
--------------------	----------	------	-----	---------	---------	--------------------	-----

325 i (E30)	6	2494	125	09/1986	11/1993	M20 B25 (256E1) M20 B25 (256E2) M20 B25 (256EX) M20 B25 (256K1)	474
--------------------	----------	------	-----	---------	---------	--	-----



BMW	ccm	kW	→	→		
325 i (E36)	6	2494	141	09/1990	12/1995	M50 B25 476 (256S1) M50 B25 478 (256S2)
325 i (E46)	6	2494	137	09/2000	04/2005	M54 B25 486 (256S5)
325 i (E46)	6	2494	141	09/2000	02/2005	M54 B25 486 (256S5)
325 i (E90/91/92/93)	6	2497	155	12/2004	06/2013	N52 B25 A 490 N52 B25 AF N52 B25 B N52 B25 BF
325 i (E90/91/92/93)	6	2497	160	12/2004	12/2011	N52 B25 A 490 N52 B25 AF N52 B25 B N52 B25 BF
325 i (E90/91/92/93)	6	2497	163	09/2008	12/2009	N52 B25 490
325 i (E90/91/92/93)	6	2497	150	03/2010	10/2013	N52 B25 A 490 N52 B25 AF N52 B25 BF
325 i (E90/91/92/93)	6	2996	160	09/2005	12/2013	N52 B30 A 520 N53 B30 A 524
325 i (E90/91/92/93)	6	2996	155	10/2006	12/2013	N53 B30 A 524
325 td (E36)	6	2497	85	09/1991	02/1998	M51 D25 488 (256T1)
325 td (E36)	6	2503	105	05/1993	04/1999	M51 D25 488 (256T1)
325 ti (E46)	6	2494	141	04/2001	12/2004	M54 B25 486 (256S5)
328 Ci (E46)	6	2793	142	12/1998	05/2000	M52 B28 494 (286S2)
328 i (E36)	6	2793	142	01/1995	11/1999	M52 B28 494 (286S1)
328 i (E46)	6	2793	142	02/1998	06/2000	M52 B28 494 (286S2)
328 i (E46)	6	2793	144	09/1998	12/2000	M52 B28 494 (286S2)
328 i (E90/91/92/93)	6	2996	172	06/2006	12/2013	N51 B30 A 518 N52 B30 A 520
328 i (E90/91/92/93)	6	2996	171	09/2006	06/2012	N51 B30 A 518 N52 B30 A 520
328 i (F30/31/34/35)	4	1997	160	11/2011	06/2015	N20 B20 A 456
328 i (F30/31/34/35)	4	1997	180	11/2011	10/2018	N20 B20 A 456 N20 B20 C 458 N26 B20 A
328 i (F30/31/34/35)	4	1997	179	07/2012	07/2016	N20 B20 A 456 N26 B20 A 458
330 Cd (E46)	6	2993	150	03/2003	12/2007	M57 D30 508 (306D2)
330 Ci (E46)	6	2979	168	06/2000	12/2006	M54 B30 498 (306S3)

BMW	ccm	kW	→	→		
330 Ci (E46)	6	2979	170	06/2000	08/2006	M54 B30 498 (306S3)
330 d (E46)	6	2926	135	10/1999	02/2005	M57 D30 496 (306D1)
330 d (E46)	6	2993	150	08/2002	05/2005	M57 D30 508 (306D2)
330 d (E90/91/92/93)	6	2993	170	12/2004	12/2013	M57 D30 510 (306D3)
330 d (E90/91/92/93)	6	2993	155	06/2005	05/2012	M57 D30 510 (306D3) N57 D30 A 514
330 d (E90/91/92/93)	6	2993	180	02/2008	12/2013	N57 D30 A 514
330 d (F30/31/34/35)	6	2993	190	07/2012		N57 D30 A 514
330 d (F30/31/34/35)	6	2993	210	07/2012		N57 D30 A 514
330 d (G20/21)	6	2993	195	03/2019		B57 D30 A 504
330 d (G20/21)	6	2993	210	11/2020		B57 D30 B 506
330 e (F30/31/35)	4	1998	135	11/2015	10/2018	B48 B20 A 466
330 e (F30/31/35)	4	1998	185	11/2015	10/2018	B48 B20 A 466
330 e (G20/21)	4	1998	135	07/2019		B46 B20 B 462 B48 B20 A 466 B48 B20 B 468
330 e (G20/21)	4	1998	185	07/2019	02/2020	B46 B20 B 462 B48 B20 A 466 B48 B20 B 468
330 e (G20/21)	4	1998	215	03/2020		B46 B20 B 462 B48 B20 A 466 B48 B20 B 468
330 i (E46)	6	2979	170	06/2000	07/2006	M54 B30 498 (306S3)
330 i (E46)	6	2979	168	01/2001	04/2005	M54 B30 498 (306S3)
330 i (E90/91/92/93)	6	2996	190	12/2004	10/2013	N52 B30 A 520 N52 B30 AF 522 N52 B30 BF
330 i (E90/91/92/93)	6	2996	200	09/2006	10/2013	N52 B30 A 520 N52 B30 AF 522 N52 B30 BF 524 N53 B30 A
330 i (F30/31/34/35)	4	1998	185	07/2015		B46 B20 B 462 B48 B20 A 466 B48 B20 B 468
330 i (F30/31/34/35)	4	1998	183	07/2016		B48 B20 B 468
330 i (G20/21)	4	1998	190	11/2018		B46 B20 B 462 B48 B20 B 468
335 d (E90/91/92/93)	6	2993	210	03/2006	03/2013	M57 D30 512 (306D5)
335 d (E90/91/92/93)	6	2993	198	09/2008	12/2011	M57 D30 512 (306D4)
335 d (F30/31/34/35)	6	2993	230	07/2013		N57 D30 B 516



BMW	ccm	kW	→	→		
335 i (E90/91/92/93)	6	2979	220	03/2006	12/2011	N54 B30 A 498 N55 B30 A 500
335 i (E90/91/92/93)	6	2979	224	03/2006	10/2013	N54 B30 A 498
335 i (E90/91/92/93)	6	2979	240	03/2006	10/2013	N54 B30 A 498 N55 B30 A 500
335 i (E90/91/92/93)	6	2979	225	06/2006	12/2013	N54 B30 A 498 N55 B30 A 500
335 i (F30/31/34/35)	6	2979	224	11/2011	12/2015	N55 B30 A 500
335 i (F30/31/34/35)	6	2979	225	11/2011	06/2016	N55 B30 A 500
335 i (F30/31/34/35)	6	2979	240	11/2011	03/2014	N55 B30 A 500
335 i (F30/31/34/35)	6	2979	250	07/2013	06/2016	N55 B30 A 500
340 i (F30/31/34/35)	6	2998	240	07/2015		B58 B30 A 526
340 i (F30/31/34/35)	6	2998	265	07/2015		B58 B30 A 526
418 d (F32/36/82)	4	1995	100	03/2014	12/2020	B47 D20 A 440 N47 D20 C 452
418 d (F32/36/82)	4	1995	105	03/2014	06/2015	N47 D20 C 452
418 d (F32/36/82)	4	1995	110	03/2015	12/2020	B47 D20 A 440
418 i (F32/33/36/82/83)	3	1499	100	07/2015		B38 B15 A 412
420 d (F32/33/36/82/83)	4	1995	120	07/2013		B47 D20 A 440 N47 D20 C 452
420 d (F32/33/36/82/83)	4	1995	135	07/2013	06/2015	N47 D20 C 452
420 d (F32/33/36/82/83)	4	1995	147	07/2013	06/2015	N47 D20 C 452
420 d (F32/33/36/82/83)	4	1995	140	03/2015		B47 D20 A 440
420 d (G22/23)	4	1995	120	07/2020		B47 D20 B 442
420 d (G22/23)	4	1995	140	07/2020		B47 D20 B 442
420 d (G26)	4	1995	140	07/2021		B47 D20 B 442
420 i (F32/33/36/82/83)	4	1997	120	11/2013	02/2017	N20 B20 A 456 N20 B20 B
420 i (F32/33/36/82/83)	4	1997	135	11/2013	02/2017	N20 B20 A 456 N20 B20 B
420 i (F32/33/36/82/83)	4	1998	120	03/2016		B48 B20 A 466
420 i (F32/33/36/82/83)	4	1998	135	03/2016		B48 B20 A 466
420 i (G22/23)	4	1597	125	11/2020		B48 B16 A 418
420 i (G22/23)	4	1998	135	07/2020		B46 B20 B 462 B48 B20 A 466
420 i (G26)	4	1998	135	07/2021		B46 B20 B 462 B48 B20 A 466
425 d (F32/33/36/82/83)	4	1995	155	03/2014	02/2018	B47 D20 B 442 N47 D20 D 454
425 d (F32/33/36/82/83)	4	1995	160	03/2014	02/2016	N47 D20 D 454

BMW	ccm	kW	→	→		
425 d (F32/33/36/82/83)	4	1995	165	03/2016	02/2018	B47 D20 B 442
425 i (F32/33/36/82/83)	4	1998	135	06/2017		B48 B20 A 466
428 i (F32/33/36/82/83)	4	1997	180	07/2013	02/2017	N20 B20 A 456 N26 B20 A 458
430 d (F32/33/36/82/83)	6	2993	190	11/2013		N57 D30 A 514
430 d (F32/33/36/82/83)	6	2993	210	11/2013		N57 D30 A 514
430 d (G22/23)	6	2993	210	03/2021		B57 D30 B 506
430 i (F32/33/36/82/83)	4	1998	183	03/2016		B48 B20 B 468
430 i (F32/33/36/82/83)	4	1998	185	03/2016		B46 B20 B 462 B48 B20 B 468
430 i (G22/23)	4	1998	190	07/2020		B46 B20 B 462 B48 B20 B 468
430 i (G22/23)	4	1998	180	07/2021		B46 B20 B 462 B48 B20 B 468
430 i (G26)	4	1998	180	07/2021		B46 B20 B 462 B48 B20 B 468
435 d (F32/33/36/82/83)	6	2993	230	11/2013		N57 D30 B 516
435 i (F32/33/36/82/83)	6	2979	225	07/2013	02/2016	N55 B30 A 500
435 i (F32/33/36/82/83)	6	2979	250	07/2013	02/2016	N55 B30 A 500
440 i (F32/33/36/82/83)	6	2998	240	03/2016		B58 B30 A 526
440 i (F32/33/36/82/83)	6	2998	265	03/2016		B58 B30 A 526
518 d (F10/11/18)	4	1995	100	07/2013	02/2017	B47 D20 A 440 N47 D20 C 452
518 d (F10/11/18)	4	1995	105	07/2013	06/2014	N47 D20 C 452
518 d (F10/11/18)	4	1995	120	10/2013	02/2017	B47 D20 A 440
518 d (F10/11/18)	4	1995	110	07/2014	02/2017	B47 D20 A 440
518 d (G30/31)	4	1995	100	07/2018		B47 D20 B 442
518 d (G30/31)	4	1995	110	07/2018		B47 D20 B 442
518 g (E34)	4	1796	85	02/1996	07/1996	M43 B18 (184E2) 426
518 i (E12)	4	1776	75	06/1979	06/1981	M10 B18 (184EB) 422
518 i (E28)	4	1766	77	05/1981	12/1987	M10 B18 (184EB) 422
518 i (E28)	4	1776	75	05/1981	12/1987	M10 B18 (184EB) 422
518 i (E34)	4	1796	83	09/1989	04/1994	M40 B18 (184E1) 424
518 i (E34)	4	1796	85	05/1994	07/1996	M43 B18 (184E2) 426



BMW	ccm	kW	→	→		
520/6 (E12)	6	1990	90	03/1977	06/1981	M20 B20 (206VA) 430
520 d (E39)	4	1951	100	02/2000	09/2003	M47 D20 (204D1) 430
520 d (E60/61)	4	1995	120	04/2005	05/2010	M47 D20 (204D4) 444 N47 D20 C 452
520 d (E60/61)	4	1995	110	09/2005	02/2007	M47 D20 (204D4) 444
520 d (E60/61)	4	1995	125	09/2007	12/2009	N47 D20 A 448
520 d (E60/61)	4	1995	130	09/2007	05/2010	N47 D20 A 448 N47 D20 C 452
520 d (F07/10/11/18)	4	1995	100	06/2010	02/2017	N47 D20 C 452
520 d (F07/10/11/18)	4	1995	120	06/2010	02/2017	B47 D20 A 440 N47 D20 C 452
520 d (F07/10/11/18)	4	1995	135	06/2010	02/2017	N47 D20 C 452
520 d (F07/10/11/18)	4	1995	147	06/2010	06/2014	N47 D20 C 452
520 d (F07/10/11/18)	4	1995	155	10/2013	02/2017	B47 D20 A 440
520 d (F07/10/11/18)	4	1995	140	07/2014	02/2017	B47 D20 A 440
520 d (F07/10/11/18)	4	1995	151	07/2014	02/2017	B47 D20 A 440
520 d (F10/11/18)	4	1995	120	06/2010	10/2016	B47 D20 A 440 N47 D20 C 452
520 d (F10/11/18)	4	1995	147	06/2010	06/2014	N47 D20 C 452
520 d (F10/11/18)	4	1995	100	01/2013	06/2014	N47 D20 C 452
520 d (F10/11/18)	4	1995	155	10/2013	10/2016	B47 D20 A 440
520 d (F10/11/18)	4	1995	140	07/2014	10/2016	B47 D20 A 440
520 d (F10/11/18)	4	1995	151	07/2014	10/2016	B47 D20 A 440
520 d (G30/31)	4	1995	120	09/2016		B47 D20 A 440 B47 D20 B 442
520 d (G30/31)	4	1995	140	09/2016		B47 D20 A 440 B47 D20 B 442
520 e (G30/31)	4	1998	120	03/2021		B48 B20 A 466
520 e (G30/31)	4	1998	150	03/2021		B48 B20 A 466
520 i/6 (E12)	6	1990	90	09/1976	07/1978	M20 B20 (206VA) 430
520 i (E28)	6	1990	92	06/1981	12/1987	M20 B20 (206EA) 430 M20 B20 (206EB) 430 M20 B20 (206EC) 430 M20 B20 (206EZ) 430
520 i (E28)	6	1990	95	08/1985	12/1987	M20 B20 (206KA) 430
520 i (E28)	6	1990	110	12/1986	12/1987	M20 B20 (206KA) 430

BMW	ccm	kW	→	→		
520 i (E34)	6	1990	95	06/1987	09/1990	M20 B20 (206KA) 430
520 i (E34)	6	1991	110	04/1990	07/1996	M50 B20 (206S1) 432 M50 B20 (206S2) 432
520 i (E39)	6	1991	100	01/1996	06/2003	M52 B20 (206S3) 434 M52 B20 (206S4) 434
520 i (E39)	6	1991	110	01/1996	06/2003	M52 B20 (206S3) 434 M52 B20 (206S4) 434
520 i (E39)	6	2171	120	09/2000	12/2003	M54 B22 (226S1) 470
520 i (E39)	6	2171	125	09/2000	12/2003	M54 B22 (226S1) 470
520 i (E60/61)	4	1995	120	12/2006	08/2010	N43 B20 A 444
520 i (E60/61)	4	1995	115	09/2007	02/2010	N46 B20 B 446
520 i (E60/61)	4	1995	125	09/2007	12/2010	N43 B20 A 444
520 i (E60/61)	6	2171	125	07/2003	03/2010	M54 B22 (226S1) 470
520 i (F10/11/18)	4	1592	125	07/2013	10/2016	N20 B16 A 414
520 i (F10/11/18)	4	1997	135	10/2010	02/2017	N20 B20 A 456 N20 B20 B 456
520 i (F10/11/18)	4	1997	120	09/2011	02/2017	N20 B20 A 456 N20 B20 B 456
520 i (G30/31)	4	1597	125	07/2017		B48 B16 A 418
520 i (G30/31)	4	1998	120	07/2017		B48 B20 A 466 B48 B20 B 468
520 i (G30/31)	4	1998	135	07/2017		B48 B20 A 466
520 i (G30/31)	4	1998	155	07/2017	06/2020	B48 B20 A 466 B48 B20 B 468
523 d (F10/11/18)	4	1995	135	06/2010	06/2014	N47 D20 C 452
523 d (G30/31)	4	1995	140	09/2016		B47 D20 A 440 B47 D20 B 442
523 i (E39)	6	2494	125	09/1995	08/2000	M52 B25 (256S3) 480 M52 B25 (256S4) 484
523 i (E39)	6	2494	120	09/1998	08/2000	M52 B25 (256S4) 484
523 i (E60/61)	6	2497	130	10/2004	02/2007	N52 B25 A 490 N52 B25 B 492 N52 B25 BE 492
523 i (E60/61)	6	2497	140	01/2007	12/2010	N52 B25 A 490 N52 B25 BE 492 N53 B25 A 492



BMW	ccm	kW	→	→			
523 i (F10/11/18)	4	1997	135	09/2011	10/2016	N20 B20 A N20 B20 B	456
523 i (F10/11/18)	6	2497	150	11/2009	08/2011	N52 B25 A N52 B25 AF N52 B25 B N52 B25 BF	490
523 i (F10/11/18)	6	2996	150	06/2009	08/2011	N53 B30 A	524
523 i (F10/11/18)	6	2996	155	01/2010	08/2011	N53 B30 A	524
523 i (G30/31)	4	1998	135	07/2017	06/2020	B48 B20 A	466
524 d (E28)	6	2443	63	03/1986	12/1987	M21 D24 (246DA)	472
524 td (E28)	6	2443	85	09/1983	12/1987	M21 D24 (246TA)	474
524 td (E34)	6	2443	85	03/1988	08/1991	M21 D24 (246TB)	474
525 (E12)	6	2494	107	10/1973	08/1976	M30 B25 A	474
525 (E12)	6	2494	110	08/1975	06/1981	M30 B25 (256VA)	474
525 d (E39)	6	2497	120	02/2000	05/2004	M57 D25 (256D1)	488
525 d (E60/61)	6	2497	120	03/2004	03/2010	M57 D25 (256D2)	488
525 d (E60/61)	6	2497	130	03/2004	03/2010	M57 D25 (256D2)	488
525 d (E60/61)	6	2993	145	11/2006	05/2010	M57 D30 (306D3)	510
525 d (F10/11/18)	4	1995	155	09/2011	02/2017	N47 D20 D	454
525 d (F10/11/18)	4	1995	160	09/2011	02/2017	N47 D20 D	454
525 d (F10/11/18)	6	2993	150	03/2010	08/2011	N57 D30 A	514
525 d (G30/31)	4	1995	155	07/2017	06/2019	B47 D20 B	442
525 d (G30/31)	4	1995	170	07/2017	06/2019	B47 D20 B	442
525 e 2.7 (E28)	6	2693	90	09/1981	12/1987	M20 B27 (276KA) M20 B27 (276KB)	492
525 e 2.7 (E28)	6	2693	95	09/1985	12/1987	M20 B27 (276EB) M20 B27 (276KB)	492
525 i (E28)	6	2495	110	06/1981	12/1987	M30 B25 (256EA)	474
525 i (E34)	6	2494	125	02/1988	08/1990	M20 B25 (256K1)	474
525 i (E34)	6	2494	141	03/1990	07/1996	M50 B25 (256S1) M50 B25 (256S2)	476 478
525 i (E39)	6	2494	137	09/2000	12/2003	M54 B25 (256S5)	486

BMW	ccm	kW	→	→			
525 i (E39)	6	2494	141	09/2000	05/2004	M54 B25 (256S5)	486
525 i (E60/61)	6	2494	137	07/2003	12/2009	M54 B25 (256S5)	486
525 i (E60/61)	6	2494	141	09/2003	12/2010	M54 B25 (256S5)	486
525 i (E60/61)	6	2497	155	03/2005	05/2010	N52 B25 A	490
525 i (E60/61)	6	2497	160	03/2005	12/2010	N52 B25 A N52 B25 B N52 B25 BF	490
525 i (E60/61)	6	2996	160	03/2005	12/2010	N52 B30 A N53 B30 A	520 524
525 i (E60/61)	6	2996	155	01/2007	12/2010	N53 B30 A	524
525 i (G30/31)	4	1998	135	07/2017	06/2020	B48 B20 A B48 B20 B	466 468
525 td (E34)	6	2497	85	03/1993	07/1996	M51 D25 (256T1)	488
525 td (E34)	6	2503	105	09/1991	08/1995	M51 D25 (256T1)	488
525 td (E39)	6	2497	85	01/1997	06/2003	M51 D25 (256T1)	488
525 td (E39)	6	2503	105	01/1996	05/2004	M51 D25 (256T1)	488
525 tds (E34)	6	2503	105	12/1991	07/1996	M51 D25 (256T1)	488
528 e 2.7 (E28)	6	2693	92	03/1983	12/1987	M20 B27 (276EA)	492
528 i (E39)	6	2793	142	09/1995	08/2000	M52 B28 (286S1) M52 B28 (286S2)	494
528 i (E60/61)	6	2996	172	09/2006	12/2009	N52 B30 A	520
528 i (F07/10/11/18)	4	1997	180	09/2011	02/2017	N20 B20 A	456
528 i (F07/10/11/18)	6	2996	190	11/2009	08/2011	N53 B30 A	524
528 i (F10/11/18)	4	1997	180	09/2011	02/2017	N20 B20 A	456
528 i (F10/11/18)	4	1997	160	10/2014	10/2016	N20 B20 A	456
528 i (F10/11/18)	6	2996	179	10/2009	08/2011	N52 B30 A	520
530 d (E39)	6	2926	135	08/1998	09/2000	M57 D30 (306D1)	496
530 d (E39)	6	2926	142	09/1998	05/2004	M57 D30 (306D1)	496
530 d (E60/61)	6	2993	155	09/2002	05/2010	M57 D30 (306D2) M57 D30 (306D3)	508 510
530 d (E60/61)	6	2993	160	09/2002	09/2005	M57 D30 (306D2)	508



BMW	ccm	kW	→	→			
530 d (E60/61)	6	2993	170	02/2005	03/2007	M57 D30 (306D3)	510
530 d (E60/61)	6	2993	173	02/2007	05/2010	M57 D30 (306D3)	510
530 d (F07/10/11/18)	6	2993	180	08/2009	06/2012	N57 D30 A	514
530 d (F07/10/11/18)	6	2993	155	09/2010	02/2017	N57 D30 A	514
530 d (F07/10/11/18)	6	2993	210	09/2010	02/2017	N57 D30 A	514
530 d (F07/10/11/18)	6	2993	190	03/2011	02/2017	N57 D30 A	514
530 d (G30/31)	6	2993	183	09/2016		B57 D30 A B57 D30 B	504 506
530 d (G30/31)	6	2993	195	09/2016		B57 D30 A	504
530 d (G30/31)	6	2993	210	07/2020		B57 D30 B	506
530 e (G30/31)	4	1998	135	03/2017		B46 B20 B B48 B20 A	462 466
530 e (G30/31)	4	1998	185	03/2017	06/2020	B46 B20 B B48 B20 A	462 466
530 e (G30/31)	4	1998	120	07/2019		B48 B20 A	466
530 e (G30/31)	4	1998	170	07/2019	06/2020	B48 B20 A	466
530 e (G30/31)	4	1998	200	07/2020		B48 B20 A	466
530 e (G30/31)	4	1998	215	07/2020		B46 B20 B B48 B20 A	462 466
530 i (E34)	8	2997	160	09/1992	07/1996	M60 B30 (308S1)	526
530 i (E39)	6	2979	168	09/2000	06/2003	M54 B30 (306S3)	498
530 i (E39)	6	2979	170	09/2000	12/2003	M54 B30 (306S3)	498
530 i (E60/61)	6	2979	170	12/2001	02/2005	M54 B30 (306S3)	498
530 i (E60/61)	6	2979	168	01/2004	12/2005	M54 B30 (306S3)	498
530 i (E60/61)	6	2996	190	09/2004	03/2007	N52 B30 A N52 B30 BF	520
530 i (E60/61)	6	2996	187	03/2005	03/2010	N52 B30 A	520
530 i (E60/61)	6	2996	200	09/2006	12/2010	N52 B30 A N52 B30 BF N53 B30 A	520 524
530 i (E60/61)	6	2996	168	09/2007	12/2009	N52 B30 A	520
530 i (F10/11/18)	6	2996	190	03/2010	06/2013	N52 B30 A N52 B30 AF N52 B30 BF	520 522
530 i (F10/11/18)	6	2996	200	05/2011	06/2013	N53 B30 A	524
530 i (G30/31)	4	1998	183	09/2016		B48 B20 B	468
530 i (G30/31)	4	1998	185	09/2016		B46 B20 B B48 B20 B	462 468

BMW	ccm	kW	→	→			
535 d (E60/61)	6	2993	200	09/2004	12/2010	M57 D30 (306D4)	512
535 d (E60/61)	6	2993	210	01/2007	12/2010	M57 D30 (306D5)	512
535 d (F07/10/11/18)	6	2993	220	03/2010	06/2012	N57 D30 B	516
535 d (F07/10/11/18)	6	2993	230	09/2011	02/2017	N57 D30 B	516
535 i (E28)	6	3430	136	01/1985	12/1987	M30 B34 (346KA)	534
535 i (E28)	6	3430	141	01/1985	12/1987	M30 B34 (346KA)	534
535 i (E28)	6	3430	162	01/1985	12/1987	M30 B34 (346EC)	534
535 i (E34)	6	3430	155	11/1987	02/1993	M30 B34 (346KB)	534
535 i (E39)	8	3498	173	06/1996	08/1998	M62 B35 (358S1)	538
535 i (E39)	8	3498	180	09/1998	06/2003	M62 B35 (358S2)	538
535 i (E60/61)	6	2979	224	03/2007	05/2010	N54 B30 A	498
535 i (E60/61)	6	2979	225	03/2007	08/2008	N54 B30 A	498
535 i (F07/10/11/18)	6	2979	224	01/2009	02/2017	N55 B30 A	500
535 i (F07/10/11/18)	6	2979	225	01/2009	02/2017	N55 B30 A	500
535 i (F07/10/11/18)	6	2979	240	07/2013	02/2017	N55 B30 A	500
540 d (G30/31)	6	2993	235	07/2017		B57 D30 A B57 D30 B	504 506
540 d (G30/31)	6	2993	250	07/2020		B57 D30 B	506
540 i (E34)	8	3982	210	09/1992	07/1996	M60 B40 (408S1)	540
540 i (E39)	8	4398	210	03/1996	12/2003	M62 B44 (448S1) M62 B44 (448S2)	554 556
540 i (E39)	8	4398	216	01/2002	06/2003	M62 B44 (448S2)	556
540 i (E60/61)	6	2979	225	04/2006	12/2009	N54 B30 A	498
540 i (E60/61)	8	3982	220	09/2005	02/2007	N62 B40 A	544
540 i (E60/61)	8	4000	225	03/2007	12/2009	N62 B40 A	544
540 i (G30/31)	6	2998	250	09/2016		B58 B30 A B58 B30 C	526 528
540 i (G30/31)	6	2998	265	09/2016	06/2020	B58 B30 A	526
540 i (G30/31)	6	2998	245	07/2020		B58 B30 C	528
545 e (G30/31)	6	2998	210	11/2020		B58 B30 C	528
545 e (G30/31)	6	2998	290	11/2020		B58 B30 C	528
545 i (E60/61)	8	4398	242	09/2003	12/2005	N62 B44 A	558



BMW	ccm	kW	→	→		
545 i (E60/61)	8	4398	245	09/2003	12/2010	N62 B44 A 558
550 i (E60/61)	8	4799	270	07/2005	12/2010	N62 B48 A N62 B48 B 560
550 i (E60/61)	8	4799	261	09/2005	03/2010	N62 B48 B 560
550 i (F07/10/11/18)	8	3982	300	07/2012	02/2017	N63 B40 A 542
550 i (F07/10/11/18)	8	4395	300	08/2009	06/2013	N63 B44 A 546
550 i (F07/10/11/18)	8	4395	298	09/2010	06/2013	N63 B44 A 546
550 i (F07/10/11/18)	8	4395	330	07/2012	02/2017	N63 B44 A 546 N63 B44 B 548
550 i (F07/10/11/18)	8	4395	332	07/2013	10/2016	N63 B44 B 548
620 d (G32)	4	1995	120	07/2018		B47 D20 B 442
620 d (G32)	4	1995	140	07/2018		B47 D20 B 442
630 d (G32)	6	2993	155	06/2017		B57 D30 A 504 B57 D30 B 506
630 d (G32)	6	2993	183	06/2017	06/2020	B57 D30 A 504
630 d (G32)	6	2993	195	06/2017	06/2020	B57 D30 A 504
630 d (G32)	6	2993	210	07/2020		B57 D30 B 506
630 i (E63/64)	6	2996	190	09/2004	08/2007	N52 B30 A 520 N52 B30 B 522 N52 B30 BF
630 i (E63/64)	6	2996	200	09/2007	08/2010	N52 B30 A 520 N52 B30 B 522 N52 B30 BF 524 N53 B30 A
630 i (G32)	4	1998	183	06/2017	06/2020	B48 B20 B 468
630 i (G32)	4	1998	190	07/2017		B48 B20 B 468
630 i (G32)	6	2998	190	07/2019		B58 B30 C 528
635 CSi (E24)	6	3430	141	12/1977	04/1989	M30 B34 (346EC) M30 B34 (346KA) M30 B34 (346KB) 534
635 CSi (E24)	6	3430	136	12/1984	12/1986	M30 B34 (346KA) 534
635 CSi (E24)	6	3430	155	07/1987	04/1989	M30 B34 (346KB) 534
635 CSi (E24)	6	3430	162	07/1987	04/1989	M30 B34 (346EC) 534
635 CSi (E24)	6	3453	160	06/1978	04/1982	M30 B35 (346EC) 534 M30 B35 (L-Jetronic, 10:1) 536 M30 B35 (Motronic, 10:1)
635 d (E63/64)	6	2993	210	07/2007	07/2010	M57 D30 (306D5) 512

BMW	ccm	kW	→	→		
635 i (E24)	6	3430	160	05/1982	06/1987	M30 B34 (346EC) M30 B35 (Motronic, 10:1) 534
640 d (F06/12/13)	6	2993	230	09/2011	10/2018	N57 D30 B 516
640 d (G32)	6	2993	235	11/2017	06/2020	B57 D30 B 506
640 d (G32)	6	2993	250	07/2020		B57 D30 B 506
640 i (F06/12/13)	6	2979	235	07/2011	10/2018	N55 B30 A 500
640 i (G32)	6	2998	250	06/2017	06/2020	B58 B30 A 526 B58 B30 C 528
640 i (G32)	6	2998	265	06/2017	06/2020	B58 B30 A 526 B58 B30 C 528
640 i (G32)	6	2998	245	07/2020		B58 B30 C 528
645 Ci (E63/64)	8	4398	245	09/2003	08/2005	N62 B44 A 558
645 Ci (E63/64)	8	4398	242	01/2004	12/2005	N62 B44 A 558
650 i (E63/64)	8	4799	270	09/2005	08/2010	N62 B48 B 560
650 i (F06/12/13)	8	3982	300	07/2012	10/2018	N63 B40 A 542
650 i (F06/12/13)	8	4395	300	12/2010	02/2015	N63 B44 A 546
650 i (F06/12/13)	8	4395	298	09/2011	12/2012	N63 B44 A 546
650 i (F06/12/13)	8	4395	330	07/2012	10/2018	N63 B44 A 546 N63 B44 B 548
650 i (F06/12/13)	8	4395	332	07/2012	10/2018	N63 B44 B 548
725 d (G11/12)	4	1995	155	07/2016	02/2019	B47 D20 B 442
725 d (G11/12)	4	1995	170	07/2016	02/2019	B47 D20 B 442
725 i (E23)	6	2494	110	07/1977	06/1986	M30 B25 474
725 tds (E38)	6	2503	105	04/1996	11/2001	M51 D25 (256T1) 488
728 i, iL (E38)	6	2793	142	08/1995	11/2001	M52 B28 (286S1) M52 B28 (286S2) 494
728 i X (E38)	6	2793	142	11/1995	09/2001	M52 B28 (286S1) 494
730 d (E38)	6	2926	135	08/1998	04/2000	M57 D30 (306D1) 496
730 d (E38)	6	2926	142	04/2000	11/2001	M57 D30 (306D1) 496
730 d (E65/E66)	6	2993	160	06/2002	02/2005	M57 D30 (306D2) 508
730 d (E65/E66)	6	2993	150	09/2002	08/2003	M57 D30 (306D2) 508
730 d (E65/E66)	6	2993	155	09/2003	08/2008	M57 D30 (306D2) 508 M57 D30 (306D3) 510
730 d (F01-F04)	6	2993	155	02/2008	05/2015	N57 D30 A 514



BMW



BMW	ccm	kW	→	→		
730 d (F01-F04)	6	2993	180	09/2008	06/2012	N57 D30 A 514
730 d (F01-F04)	6	2993	190	11/2011	05/2015	N57 D30 A 514
730 d (G11/12)	6	2993	155	07/2015		B57 D30 A 504 B57 D30 B 506
730 d (G11/12)	6	2993	183	09/2015		B57 D30 A 504 B57 D30 B 506
730 d (G11/12)	6	2993	195	09/2015	06/2020	B57 D30 A 504
730 d (G11/12)	6	2993	210	07/2020		B57 D30 B 506
730 i, iL (E32)	8	2997	160	04/1992	09/1994	M60 B30 526 (308S1)
730 i, iL (E38)	8	2997	160	03/1994	02/1996	M60 B30 526 (308S1)
730 i, iL (E38)	8	2997	155	10/1994	11/2001	M60 B30 526 (308S1)
730 i / Li (E65/E66)	6	2979	170	03/2003	07/2008	M54 B30 498 (306S3)
730 i / Li (E65/E66)	6	2996	184	03/2005	07/2008	N52 B30 A 520
730 i / Li (E65/E66)	6	2996	190	03/2005	08/2008	N52 B30 A 520 N52 B30 BF
730 i (F01-F04)	6	2996	190	09/2009	06/2015	N52 B30 A 520 N52 B30 AF 522 N52 B30 BF
730 i (G11/12)	4	1998	183	11/2015		B48 B20 B 468
730 i (G11/12)	4	1998	190	11/2015	02/2019	B48 B20 B 468
730 i (G11/12)	4	1998	195	03/2019		B48 B20 B 468
730 Ld (E65/E66)	6	2993	170	07/2005	08/2008	M57 D30 510 (306D3)
735 i, iL (E32)	6	3430	155	06/1986	07/1992	M30 B34 534 (346KB)
735 i, iL (E32)	6	3430	162	07/1986	01/1989	M30 B35 536 (Motronic,9.2:1)
735 i, iL (E38)	8	3498	173	03/1996	08/1998	M62 B35 538 (358S1)
735 i, iL (E38)	8	3498	175	09/1998	07/2001	M62 B35 538 (358S2)
735 i / Li (E65/E66)	8	3600	200	11/2001	02/2005	N62 B36 A 540
735 i (E23)	6	3430	160	09/1979	09/1982	M30 B35 536 (346EC)
735 i (E23)	6	3430	136	05/1984	09/1986	M30 B34 534 (346KA)
735 i (E23)	6	3430	141	04/1985	08/1986	M30 B34 534 (346EC)
735 i (E23)	6	3453	160	09/1982	09/1986	M30 B34 534 (346EC)
735 i (E65/E66)	8	3999	225	03/2005	12/2009	N62 B40 A 544
740 d (F01-F04)	6	2993	225	09/2009	12/2012	N57 D30 B 516

BMW	ccm	kW	→	→		
740 d (F01-F04)	6	2993	230	07/2012	06/2015	N57 D30 B 516
740 d (G11/12)	6	2993	235	11/2015	06/2020	B57 D30 B 506
740 d (G11/12)	6	2993	250	07/2020		B57 D30 B 506
740 e (G11/12)	4	1998	190	07/2016	02/2019	B48 B20 B 468
740 e (G11/12)	4	1998	240	07/2016	02/2019	B48 B20 B 468
740 i, iL (E32)	8	3982	210	05/1992	03/1994	M60 B40 540 (408S1)
740 i, iL (E38)	8	3982	210	03/1994	02/1996	M60 B40 540 (408S1)
740 i, iL (E38)	8	4398	210	02/1996	07/2001	M62 B44 554 (448S1) M62 B44 556 (448S2)
740 i (E65/E66)	8	4000	225	03/2005	08/2008	N62 B40 A 544
740 i (F01-F04)	6	2979	240	09/2008	06/2012	N54 B30 A 498
740 i (F01-F04)	6	2979	224	09/2010	12/2015	N54 B30 A 498
740 i (F01-F04)	6	2979	235	07/2012	12/2015	N55 B30 A 500
740 i (G11/12)	6	2998	240	07/2015	02/2019	B58 B30 A 526
740 i (G11/12)	6	2998	245	03/2019		B58 B30 C 528
740 i (G11/12)	6	2998	250	03/2019		B58 B30 C 528
745 e (G11/12)	6	2998	210	03/2019		B58 B30 C 528
745 e (G11/12)	6	2998	290	03/2019		B58 B30 C 528
745 i /Li (E65/E66)	8	4398	245	07/2001	03/2005	N62 B44 A 558
745 i /Li (E65/E66)	8	4398	241	11/2001	12/2003	N62 B44 A 558
745 i /Li (E65/E66)	8	4398	242	09/2003	12/2005	N62 B44 A 558
745 i (E23)	6	3430	185	05/1983	08/1986	M30 B34 534 (346TA)
750 d (F01-F04)	6	2993	280	07/2012	12/2015	N57 D30 C 518
750 d (G11/12)	6	2993	294	07/2016		B57 D30 C 506
750 i, iL (E32)	12	4988	220	09/1987	09/1994	M70 B50 562 (5012A)
750 i, iL (E32)	12	5379	243	09/1998	07/2001	M73 B54 564 (54122)
750 i, iL (E38)	12	5379	240	11/1994	07/2001	M73 B54 564 (54121) M73 B54 564 (54122)
750 i /Li (E65/E66)	8	4799	270	03/2005	08/2008	N62 B48 B 560
750 i (F01-F04)	8	3982	300	07/2013	06/2015	N63 B40 A 542
750 i (F01-F04)	8	4395	298	09/2008	08/2015	N63 B44 B 548
750 i (F01-F04)	8	4395	300	09/2008	06/2012	N63 B44 A 546
750 i (F01-F04)	8	4395	330	07/2012	06/2015	N63 B44 B 548

BMW



BMW	ccm	kW	→	→		
750 i (F01-F04)	8	4395	331	09/2012	06/2015	N63 B44 B 548
750 i (G11/12)	8	4395	330	09/2015	02/2019	N63 B44 C 548
750 i (G11/12)	8	4395	390	03/2019		N63 B44 D 550
840 Ci (E31)	8	4398	210	03/1996	06/1999	M62 B44 (448S1) 554
840 d (G14/15/16)	6	2993	235	07/2018	10/2020	B57 D30 B 506
840 d (G14/15/16)	6	2993	250	11/2020		B57 D30 B 506
840 i (E31)	8	3982	210	03/1993	02/1996	M60 B40 (408S1) 540
840 i (G14/15/16)	6	2998	250	07/2019		B58 B30 C 528
840 i (G14/15/16)	6	2998	245	11/2020		B58 B30 C 528
850 Ci (E31)	12	4988	220	01/1990	08/1994	M70 B50 (5012A) 562
850 Ci (E31)	12	5379	240	09/1994	12/1999	M73 B54 (54121) 564
850 CSi (E31)	12	5576	280	11/1992	12/1996	S70 B56 (56121) 564
850 CSi (E31)	12	5576	277	09/1993	12/1995	S70 B56 (56121) 564
ActiveHybrid (E71/72)	8	4395	300	01/2009	10/2011	N63 B44 A 546
ActiveHybrid (E71/72)	8	4395	357	01/2009	10/2011	N63 B44 A 546
ActiveHybrid (F01-F04)	6	2979	235	08/2012	06/2015	N55 B30 A 500
ActiveHybrid (F01-F04)	6	2979	260	08/2012	06/2015	N55 B30 A 500
ActiveHybrid (F01-F04)	8	4395	330	04/2010	06/2012	N63 B44 A 546
ActiveHybrid (F01-F04)	8	4395	342	04/2010	06/2012	N63 B44 A 546
ActiveHybrid (F10/11/18)	6	2979	225	12/2011	10/2016	N55 B30 A 500
ActiveHybrid (F10/11/18)	6	2979	250	12/2011	10/2016	N55 B30 A 500
ActiveHybrid (F30/31/35)	6	2979	225	07/2012	06/2015	N55 B30 A 500
ActiveHybrid (F30/31/35)	6	2979	250	07/2012	06/2015	N55 B30 A 500
i3	2	647	75	08/2013		W20K06A 408
i3	2	647	125	08/2013		W20K06A 408
i3	2	647	135	11/2017		W20K06A 408
i8	3	1499	170	03/2014	06/2020	B38 K15 A 412
i8	3	1499	266	03/2014	02/2018	B38 K15 A 412
i8	3	1499	275	03/2018	06/2020	B38 K15 A 412
M 135 i (F20/21)	6	2979	235	12/2011		N55 B30 A 500
M 135 i (F20/21)	6	2979	240	03/2015		N55 B30 A 500

BMW	ccm	kW	→	→		
M 140 i (F20/21)	6	2998	250	09/2015		B58 B30 A 526
M2 (F22/87)	6	2979	272	11/2015	06/2018	N55 B30 A 500
M2 (F22/87)	6	2979	302	06/2018		S55 B30 A 500
M2 (F22/87)	6	2979	331	11/2019		S55 B30 A 500
M 235 i (F22/23)	6	2979	240	10/2013		N55 B30 A 500
M 235 i (F22/23)	6	2979	235	03/2014		N55 B30 A 500
M 240 i (F22/23)	6	2998	250	09/2015		B58 B30 A 526
M 240 i (G42)	6	2998	275	08/2021		B58 B30 B 528
M3 (E90/91/92/93)	8	3999	309	06/2007	10/2013	S65 B40 A 542
M3 (F80)	6	2979	317	03/2014	10/2018	S55 B30 A 500
M3 (F80)	6	2979	331	03/2016	10/2018	S55 B30 A 500
M3 (F80)	6	2979	338	01/2018	10/2018	S55 B30 A 500
M3 2.3 (E30)	4	2302	147	06/1988	07/1989	S14 B23 (234EA) 470
M3 2.3 (E30)	4	2303	158	01/1986	10/1993	S14 B23 (234EA) S14 B23 (234S2) 470
M3 2.3 (E30)	4	2303	143	07/1986	06/1991	S14 B23 (234EA) S14 B23 (234S1) S14 B23 (234S2) 470
M3 2.3 (E30)	4	2303	147	02/1987	05/1989	S14 B23 (234EA) S14 B23 (234S2) 470
M3 3.0 (E36)	6	2990	210	11/1992	07/1995	S50 B30 (306S1) 502
M3 3.0 (E36)	6	2990	217	09/1993	05/1995	S50 B30 (306S1) 502
M3 3.0 (E36)	6	2990	176	03/1994	12/1995	S50 B30 (306S2) 502
M3 3.2 (E36)	6	3152	179	09/1996	09/1999	S52 B32 (326S2) 530
M3 3.2 (E36)	6	3201	236	10/1995	09/1999	S50 B32 (326S1) 532
M3 3.2 (E46)	6	3246	252	07/2000	08/2006	S54 B32 (326S4) 532
M3 3.2 8E36)	6	3152	179	06/1996	04/1999	S52 B32 (326S2) 530
M 340 d (G20/21/80)	6	2993	250	04/2020		B57 D30 B 506
M 340 d (G20/21)	6	2993	250	04/2020		B57 D30 B 506
M 340 i (G20/21/80)	6	2998	285	03/2019		B58 B30 B 528
M 340 i (G20/21/80)	6	2998	275	07/2019		B58 B30 B 528



BMW	ccm	kW	→	→		
M 340 i (G20)	6	2998	275	11/2020		B58 B30 B 528
M3 CSL (E46)	6	3246	265	05/2003	12/2003	S54 B32 (326S4) 532
M3 EVO I 2.3 (E30)	4	2302	162	10/1988	10/1990	S14 B23 (234EA) 470
M4 (F32/33/82/83)	6	2979	317	03/2014		S55 B30 A 500
M4 (F32/33/82/83)	6	2979	331	03/2016		S55 B30 A 500
M 440 (G22/23)	6	2998	275	11/2020		B58 B30 B 528
M 440 d (G22/23)	6	2993	250	03/2021		B57 D30 B 506
M 440 i (G22/23)	6	2998	285	07/2020		B58 B30 B 528
M 440 i (G22/23)	6	2998	275	11/2020		B58 B30 B 528
M 440 i (G26)	6	2998	275	07/2021		B58 B30 B 528
M 440 i (G26)	6	2998	285	07/2021		B58 B30 B 528
M4 CS (F32/82)	6	2979	338	07/2017	06/2019	S55 B30 A 500
M4 GTS (F32/82)	6	2979	368	03/2016	02/2017	S55 B30 A 500
M5 (E39)	8	4941	294	10/1998	06/2003	S62 B50 (508S1) 562
M5 (E60/61)	10	4999	373	09/2004	12/2010	S85 B50 A 562
M5 (F10/11/18)	8	4395	412	09/2011	10/2016	S63 B44 B 552
M5 (F10/11/18)	8	4395	423	02/2013	10/2016	S63 B44 B 552
M5 (F10/11/18)	8	4395	418	09/2013	10/2016	S63 B44 B 552
M5 (F10/11/18)	8	4395	441	07/2014	10/2016	S63 B44 B 552
M5 (G30/31)	8	4395	441	09/2017		S63 B44 B 552
M5 (G30/31)	8	4395	460	07/2018		S63 B44 B 552
M 535 i (E12)	6	3453	160	04/1980	05/1981	M30 B35 (356EA) 536
M 535 i (E28)	6	3430	160	01/1985	12/1987	M30 B34 (346EA) 534
M 550 d (F10/11/18)	6	2993	280	03/2012	02/2017	N57 D30 C 518
M 550 d (G30/31)	6	2993	294	06/2017		B57 D30 C 506
M 550 i (G30/31)	8	4395	340	03/2017	06/2019	N63 B44 C 548
M 550 i (G30/31)	8	4395	390	07/2019		N63 B44 D 550
M5 CS (G30/31)	8	4395	467	03/2021		S63 B44 B 552
M6 (E63/64)	10	4999	373	09/2005	08/2010	S85 B50 A 562
M6 (F06/12/13)	8	4395	412	03/2012	10/2018	S63 B44 B 552
M6 (F06/12/13)	8	4395	418	07/2012	10/2017	S63 B44 B 552
M6 (F06/12/13)	8	4395	423	07/2013	02/2015	S63 B44 B 552
M6 (F06/12/13)	8	4395	441	03/2015	10/2018	S63 B44 B 552
M8 (G14)	8	4395	441	07/2019		S63 B44 B 552

BMW	ccm	kW	→	→		
M8 (G14)	8	4395	460	07/2019		S63 B44 B 552
M 850 i (G14)	8	4395	390	11/2018		N63 B44 D 550
M 850 i (G15)	8	4395	390	10/2018		N63 B44 D 550
M 850 i (G16)	8	4395	390	07/2019		N63 B44 D 550
X1 16 d (E84)	4	1995	85	04/2012	06/2015	N47 D20 C 452
X1 16 d (F84)	3	1496	85	11/2014		B37 C15 A 408
X1 16 i (E84)	4	1592	105	03/2013	06/2015	N20 B16 A 414
X1 18 d (E84)	4	1995	100	03/2009	06/2015	N47 D20 C 452
X1 18 d (E84)	4	1995	105	10/2009	06/2015	N47 D20 C 452
X1 18 d (F48)	4	1995	100	11/2014		B47 C20 A 436
X1 18 d (F48)	4	1995	110	11/2014		B47 C20 A 436 B47 C20 B 438
X1 18 i (E84)	4	1995	100	03/2010	06/2015	N46 B20 B 446 N46 B20 BD 448
X1 18 i (E84)	4	1995	110	03/2010	06/2015	N46 B20 B 446 N46 B20 BD 448 N46 B20 C N46 B20 CC N46 B20 CD N46 B20 E
X1 18 i (F48)	3	1499	100	11/2015	02/2018	B38 A15 A 410
X1 18 i (F48)	3	1499	103	07/2017		B38 A15 A 410
X1 20 d (E84)	4	1995	130	09/2009	06/2015	N47 D20 C 452
X1 20 d (E84)	4	1995	120	03/2010	06/2015	N47 D20 C 452
X1 20 d (E84)	4	1995	135	07/2012	06/2015	N47 D20 C 452
X1 20 d (F48)	4	1995	120	07/2015		B47 C20 A 436 B47 C20 B 438
X1 20 d (F48)	4	1995	140	07/2015		B47 C20 A 436 B47 C20 B 438
X1 20 i (E84)	4	1997	135	09/2011	06/2015	N20 B20 A 456
X1 20 i (F48)	4	1998	141	07/2015		B42 S20 A 460 B48 A20 A 462 B48 A20 B 464
X1 20 i (F48)	4	1998	131	11/2020		B48 A20 A 462
X1 23 d (E84)	4	1995	150	10/2009	06/2015	N47 D20 D 454
X1 25 d (E84)	4	1995	160	10/2009	06/2015	N47 D20 D 454
X1 25 d (E84)	6	2996	160	03/2010	08/2011	N52 B30 A 520
X1 25 d (F48)	4	1995	170	11/2014		B47 C20 B 438
X1 25 e (F48)	3	1499	92	03/2020		B38 A15 A 410
X1 25 e (F48)	3	1499	162	03/2020		B38 A15 A 410
X1 25 i (F48)	4	1998	170	07/2015		B42 S20 A 460 B46 A20 B 464 B48 A20 B



BMW	ccm	kW	→	→			
X1 28 i (E84)	4	1997	180	03/2011	06/2015	N20 B20 A	456
X1 28 i (E84)	6	2996	190	09/2009	08/2011	N52 B30 A	520
X1 28 i (E84)	6	2996	194	03/2010	06/2011	N52 B30 A	520
X1 28 i (F48)	4	1998	170	11/2014		B46 A20 B	460
X2 16 d (F39)	3	1496	85	11/2018		B37 C15 A	408
X2 18 d (F39)	4	1995	100	03/2018		B47 C20 A B47 C20 B	436 438
X2 18 d (F39)	4	1995	110	03/2018		B47 C20 A B47 C20 B	436 438
X2 18 i (F39)	3	1499	100	03/2018		B32 S15 A B38 A15 A	410
X2 18 i (F39)	3	1499	103	03/2018		B38 A15 A	410
X2 20 d (F39)	4	1995	120	11/2017		B47 C20 A B47 C20 B	436 438
X2 20 d (F39)	4	1995	140	11/2017		B47 C20 A B47 C20 B	436 438
X2 20 d (F39)	4	1995	100	03/2018		B47 C20 B	438
X2 20 i (F39)	4	1998	141	11/2017		B42 S20 A B48 A20 A	460 462
X2 20 i (F39)	4	1998	131	11/2020		B48 A20 A	462
X2 25 d (F39)	4	1995	170	11/2017		B47 C20 B	438
X2 25 e (F39)	3	1499	92	03/2020		B38 A15 A	410
X2 25 e (F39)	3	1499	162	03/2020		B38 A15 A	410
X2 28 i (F39)	4	1998	170	11/2017		B46 A20 B	460
X3 18 d (E83)	4	1995	105	09/2008	12/2011	N47 D20 C	452
X3 18 d (E83)	4	1995	100	04/2009	12/2011	N47 D20 C	452
X3 18 d (F25)	4	1995	100	10/2012	03/2014	N47 D20 C	452
X3 18 d (F25)	4	1995	105	10/2012	03/2014	N47 D20 C	452
X3 18 d (F25)	4	1995	110	04/2014	08/2017	B47 D20 A	440
X3 18 d (G01)	4	1995	100	04/2018		B47 D20 A B47 D20 B	440 442
X3 18 d (G01)	4	1995	110	04/2018		B47 D20 A B47 D20 B	440 442
X3 18 i (F25)	4	1592	125	04/2014	08/2017	N20 B16 A	414
X3 20 d (E83)	4	1995	110	09/2004	08/2007	M47 D20 (204D4)	444
X3 20 d (E83)	4	1995	130	09/2007	08/2010	N47 D20 A N47 D20 C	448 452
X3 20 d (E83)	4	1995	120	09/2008	08/2010	N47 D20 A N47 D20 C	448 452
X3 20 d (F25)	4	1995	120	09/2010	03/2014	N47 D20 C	452
X3 20 d (F25)	4	1995	135	09/2010	03/2014	N47 D20 C	452

BMW	ccm	kW	→	→			
X3 20 d (F25)	4	1995	140	04/2014	08/2017	B47 D20 A	440
X3 20 d (G01)	4	1995	120	08/2017		B47 D20 A B47 D20 B	440 442
X3 20 d (G01)	4	1995	140	08/2017		B47 D20 A B47 D20 B	440 442
X3 20 i (E83)	4	1995	110	07/2005	08/2011	N46 B20 B	446
X3 20 i (F25)	4	1997	135	10/2011	08/2017	N20 B20 A	456
X3 20 i (G01)	4	1597	125	12/2017		B48 B16 A	418
X3 20 i (G01)	4	1998	135	12/2017		B46 B20 B B48 B20 A B48 B20 B	462 466 468
X3 25 d (G01)	4	1995	155	04/2018		B47 D20 B	442
X3 25 d (G01)	4	1995	170	04/2018		B47 D20 B	442
X3 25 i (E83)	6	2494	137	01/2004	12/2006	M54 B25 (256S5)	486
X3 25 i (E83)	6	2494	141	03/2004	07/2006	M54 B25 (256S5)	486
X3 25 i (E83)	6	2497	155	08/2006	08/2010	N52 B25 A N52 B25 AF N52 B25 BF	490
X3 25 i (E83)	6	2497	160	08/2006	08/2010	N52 B25 A N52 B25 AF N52 B25 BF	490
X3 28 d (F25)	4	1995	134	04/2014	12/2016	N47 D20 C	452
X3 28 i (F25)	4	1997	180	04/2012	08/2017	N20 B20 A	456
X3 28 i (F25)	6	2996	190	01/2011	10/2012	N52 B30 A N52 B30 AF N52 B30 BF	520 522
X3 30 d (E83)	6	2993	150	01/2004	08/2005	M57 D30 (306D2)	508
X3 30 d (E83)	6	2993	155	09/2005	08/2010	M57 D30 (306D3)	510
X3 30 d (E83)	6	2993	160	09/2005	08/2010	M57 D30 (306D3)	510
X3 30 d (E83)	6	2993	210	09/2006	08/2008	M57 D30 (306D5)	512
X3 30 d (F25)	6	2993	155	04/2011	08/2017	N57 D30 A	514
X3 30 d (F25)	6	2993	190	04/2011	08/2017	N57 D30 A	514
X3 30 d (F25)	6	2993	210	04/2011	05/2016	N57 D30 A	514
X3 30 d (F25)	6	2993	183	06/2011	08/2017	N57 D30 A	514
X3 30 d (F25)	6	2993	204	06/2016	08/2017	N57 D30 A	514
X3 30 d (G01)	6	2993	195	08/2017		B57 D30 A	504
X3 30 d (G01)	6	2993	183	12/2017		B57 D30 A B57 D30 B	504 506
X3 30 d (G01)	6	2993	210	07/2020		B57 D30 B	506



BMW		ccm	kW	→	→		
X3 30 e (G01)	4	1998	120	12/2019		B46 B20 B B48 B20 A	462 466
X3 30 e (G01)	4	1998	135	12/2019		B46 B20 B B48 B20 A	462 466
X3 30 e (G01)	4	1998	170	12/2019		B46 B20 B B48 B20 A	462 466
X3 30 e (G01)	4	1998	185	12/2019		B46 B20 B B48 B20 A	462 466
X3 30 i (E83)	6	2979	170	09/2003	07/2006	M54 B30 (306S3)	498
X3 30 i (E83)	6	2979	168	01/2004	12/2006	M54 B30 (306S3)	498
X3 30 i (E83)	6	2996	160	08/2006	08/2010	N52 B30 A	520
X3 30 i (E83)	6	2996	200	08/2006	08/2010	N52 B30 A N52 B30 BF	520
X3 30 i (E83)	6	2996	194	09/2006	08/2010	N52 B30 A	520
X3 30 i (G01)	4	1998	183	08/2017		B48 B20 B	468
X3 30 i (G01)	4	1998	185	08/2017		B46 B20 B B48 B20 B	462 468
X3 30 i (G01)	4	1998	180	08/2021		B46 B20 B B48 B20 B	462 468
X3 35 d (E83)	6	2993	210	09/2008	08/2011	M57 D30 (306D5)	512
X3 35 d (F25)	6	2993	230	10/2011	08/2017	N57 D30 B	516
X3 35 i (F25)	6	2979	225	09/2010	08/2017	N55 B30 A	500
X3 M 40 d (G01)	6	2993	240	08/2018	06/2020	B57 D30 B	506
X3 M 40 d (G01)	6	2993	250	08/2018		B57 D30 B	506
X3 M 40 i (G01)	6	2998	265	08/2017		B58 B30 A B58 B30 B	526 528
X3 M 40 i (G01)	6	2998	260	09/2018	08/2019	B58 B30 A	526
X3 M 40 i (G01)	6	2998	285	09/2019		B58 B30 B	528
X4 20 d (F26)	4	1995	120	04/2014	03/2018	B47 D20 A	440
X4 20 d (F26)	4	1995	140	04/2014	03/2018	B47 D20 A	440
X4 20 d (G02)	4	1995	120	04/2018		B47 D20 A B47 D20 B	440 442
X4 20 d (G02)	4	1995	140	04/2018		B47 D20 A B47 D20 B	440 442
X4 20 i (F26)	4	1997	135	04/2014	03/2018	N20 B20 A	456
X4 20 i (G02)	4	1998	135	04/2018		B46 B20 B B48 B20 A	462 466
X4 25 d (G02)	4	1995	155	04/2018		B47 D20 B	442
X4 25 d (G02)	4	1995	170	04/2018		B47 D20 B	442
X4 28 i (F26)	4	1997	179	04/2014	03/2018	N20 B20 A	456
X4 28 i (F26)	4	1997	180	04/2014	03/2018	N20 B20 A	456

BMW		ccm	kW	→	→		
X4 30 d (F26)	6	2993	155	04/2014	03/2018	N57 D30 A	514
X4 30 d (F26)	6	2993	190	04/2014	03/2018	N57 D30 A	514
X4 30 d (F26)	6	2993	204	04/2014	03/2018	N57 D30 A	514
X4 30 d (F26)	6	2993	210	04/2014	03/2018	N57 D30 A	514
X4 30 d (F26)	6	2993	183	04/2015	03/2018	N57 D30 A	514
X4 30 d (G02)	6	2993	195	04/2018	06/2020	B57 D30 A	504
X4 30 d (G02)	6	2993	183	09/2018		B57 D30 A B57 D30 B	504 506
X4 30 d (G02)	6	2993	210	07/2020		B57 D30 B	506
X4 30 i (G02)	4	1998	183	04/2018		B48 B20 B	468
X4 30 i (G02)	4	1998	185	04/2018		B46 B20 B B48 B20 B	462 468
X4 30 i (G02)	4	1998	180	07/2021		B46 B20 B B48 B20 B	462 468
X4 35 d (F26)	6	2993	230	04/2014	03/2018	N57 D30 B	516
X4 35 i (F26)	6	2979	225	04/2014	03/2018	N55 B30 A	500
X4 35 i (F26)	6	2979	224	01/2015	03/2018	N55 B30 A	500
X4 M 40 d (G02)	6	2993	240	04/2018	06/2020	B57 D30 B	506
X4 M 40 d (G02)	6	2993	250	07/2020		B57 D30 B	506
X4 M 40 i (F26)	6	2979	265	12/2015	03/2018	N55 B30 A	500
X4 M 40 i (G02)	6	2998	260	04/2018	08/2019	B58 B30 A	526
X4 M 40 i (G02)	6	2998	265	04/2018		B58 B30 A B58 B30 B	526 528
X4 M 40 i (G02)	6	2998	285	09/2019		B58 B30 B	528
X5 25 d (F15/85)	4	1995	155	12/2013	07/2015	N47 D20 D	454
X5 25 d (F15/85)	4	1995	160	12/2013	07/2015	N47 D20 D	454
X5 25 d (F15/85)	4	1995	170	08/2015	07/2018	B47 D20 B	442
X5 25 d (F15/85)	6	2993	160	04/2014	07/2018	N57 D30 A	514
X5 25 d (G05)	4	1995	155	08/2019		B47 D20 B	442
X5 25 d (G05)	4	1995	170	08/2019		B47 D20 B	442
X5 28 i (F15/85)	4	1997	180	06/2015	07/2018	N20 B20 A	456
X5 3.0 d (E53)	6	2925	135	04/2001	09/2003	M57 D30 (306D1)	496
X5 3.0 d (E53)	6	2993	155	10/2003	09/2006	M57 D30 (306D2)	508
X5 3.0 d (E53)	6	2993	160	10/2003	09/2006	M57 D30 (306D2)	508
X5 3.0 i (E53)	6	2979	170	04/2000	10/2006	M54 B30 (306S3)	498
X5 3.0 i (E53)	6	2979	168	06/2000	12/2006	M54 B30 (306S3)	498



BMW	ccm	kW	→	→		
X5 3.0 i (E70)	6	2996	200	10/2006	09/2008	N52 B30 A 520 N52 B30 AF 522 N52 B30 BF
X5 30 d (E70)	6	2993	173	12/2006	03/2010	M57 D30 (306D3) 510
X5 30 d (E70)	6	2993	155	02/2007	07/2013	M57 D30 (306D3) 510 N57 D30 A 514
X5 30 d (E70)	6	2993	210	10/2007	09/2008	M57 D30 (306D5) 512
X5 30 d (E70)	6	2993	180	04/2010	07/2013	N57 D30 A 514
X5 30 d (F15/85)	6	2993	190	08/2013	07/2018	N57 D30 A 514
X5 30 d (F15/85)	6	2993	204	08/2013	07/2018	N57 D30 A 514
X5 30 d (F15/85)	6	2993	210	08/2013	07/2018	N57 D30 A 514
X5 30 d (F15/85)	6	2993	183	12/2013	07/2018	N57 D30 A 514
X5 30 d (G05)	6	2993	183	08/2018		B57 D30 A 504 B57 D30 B 506
X5 30 d (G05)	6	2993	195	08/2018		B57 D30 A 504
X5 30 d (G05)	6	2993	210	08/2020		B57 D30 B 506
X5 30 i (E70)	6	2996	172	02/2007	12/2012	N52 B30 A 520
X5 30 i (E70)	6	2996	194	09/2008	12/2010	N52 B30 A 520
X5 30 i (E70)	6	2996	200	10/2008	03/2010	N52 B30 A 520
X5 30 i (G05)	4	1998	195	09/2019		B48 B20 B 468
X5 35 d (E70)	6	2993	210	10/2008	07/2013	M57 D30 (306D5) 512
X5 35 i (E70)	6	2979	225	04/2010	07/2013	N55 B30 A 500
X5 35 i (E70)	6	2979	235	02/2012	06/2013	N55 B30 A 500
X5 35 i (F15/85)	6	2979	225	08/2013	07/2018	N55 B30 A 500
X5 35 i (F15/85)	6	2979	240	12/2013	07/2018	N55 B30 A 500
X5 4.4 i (E53)	8	4398	210	01/2000	09/2003	M62 B44 (448S2) 556
X5 4.4 i (E53)	8	4398	235	10/2003	10/2006	N62 B44 A 558
X5 4.6 i (E53)	8	4619	255	10/2001	09/2003	M62 B46 (468S1) 558
X5 4.8 i (E53)	8	4799	265	04/2004	09/2006	N62 B48 A 560
X5 40 d (E70)	6	2993	225	09/2010	06/2013	N57 D30 B 516
X5 40 d (F15/85)	6	2993	230	12/2013	07/2018	N57 D30 B 516
X5 40 d (G05)	6	2993	250	05/2020		B57 D30 B 506
X5 40 e (F15/85)	4	1997	155	08/2015	07/2018	N20 B20 A 456
X5 40 e (F15/85)	4	1997	180	08/2015	07/2018	N20 B20 A 456
X5 40 e (F15/85)	4	1997	205	08/2015	07/2018	N20 B20 A 456
X5 40 e (F15/85)	4	1997	230	08/2015	07/2018	N20 B20 A 456

BMW	ccm	kW	→	→		
X5 40 i (E70)	6	2979	225	01/2012	06/2013	N55 B30 A 500
X5 40 i (G05)	6	2998	250	08/2018		B58 B30 C 528
X5 40 i (G05)	6	2998	245	12/2020		B58 B30 C 528
X5 45 e (G05)	6	2998	155	06/2019		B58 B30 C 528
X5 45 e (G05)	6	2998	210	06/2019		B58 B30 C 528
X5 45 e (G05)	6	2998	235	06/2019		B58 B30 C 528
X5 45 e (G05)	6	2998	290	06/2019		B58 B30 C 528
X5 48 i (E70)	8	4799	261	10/2006	03/2010	N62 B48 B 560
X5 50 i (E70)	8	4395	298	09/2009	06/2013	N63 B44 A 546
X5 50 i (E70)	8	4395	300	04/2010	07/2013	N63 B44 A 546
X5 50 i (F15/85)	8	3982	300	08/2013	07/2018	N63 B40 A 542
X5 50 i (F15/85)	8	4395	330	08/2013	07/2018	N63 B44 B 548
X5 50 i (F15/85)	8	4395	332	08/2013	07/2018	N63 B44 B 548
X5 50 i (G05)	8	4395	340	08/2018		N63 B44 D 550
X5 M (E70)	8	4395	408	07/2009	07/2013	S63 B44 A 550
X5 M (E70)	8	4395	414	09/2009	06/2013	S63 B44 A 550
X5 M (F15/85)	8	4395	423	12/2014	07/2018	S63 B44 B 552
X5 M (G05)	8	4395	441	12/2019		S63 B44 B 552
X5 M (G05)	8	4395	460	12/2019		S63 B44 B 552
X5 M 50 d (E70)	6	2993	280	08/2011	06/2013	N57 D30 C 518
X5 M 50 d (F05)	6	2993	294	08/2018		B57 D30 C 506
X5 M 50 d (F15/85)	6	2993	280	12/2013	07/2018	N57 D30 C 518
X5 M50 i (G05)	8	4395	390	08/2019		N63 B44 D 550
X6 28 i (F16/86)	4	1997	180	06/2015	07/2019	N20 B20 A 456
X6 30 d (E71/72)	6	2993	173	04/2008	03/2010	M57 D30 (306D3) 510
X6 30 d (E71/72)	6	2993	155	04/2010	07/2014	N57 D30 A 514
X6 30 d (E71/72)	6	2993	180	04/2010	07/2014	N57 D30 A 514
X6 30 d (F16/86)	6	2993	155	08/2014	07/2019	N57 D30 A 514
X6 30 d (F16/86)	6	2993	190	08/2014	07/2019	N57 D30 A 514
X6 30 d (F16/86)	6	2993	204	08/2014	07/2019	N57 D30 A 514
X6 30 d (F16/86)	6	2993	183	12/2014	07/2019	N57 D30 A 514
X6 30 d (F16/86)	6	2993	160	09/2016	07/2019	N57 D30 A 514
X6 30 d (G06)	6	2993	155	08/2019		B57 D30 A 504 B57 D30 B 506
X6 30 d (G06)	6	2993	183	08/2019		B57 D30 A 504 B57 D30 B 506
X6 30 d (G06)	6	2993	195	08/2019	07/2020	B57 D30 A 504



BMW		ccm	kW	→	→		
X6 30 d (G06)	6	2993	210	08/2020		B57 D30 B	506
X6 30 i (G06)	4	1998	195	11/2019		B48 B20 B	468
X6 35 d (E71/72)	6	2993	210	01/2008	03/2010	M57 D30 (306D5)	512
X6 35 i (E71/72)	6	2979	240	06/2007	03/2010	N54 B30 A	498
X6 35 i (E71/72)	6	2979	224	01/2008	06/2014	N54 B30 A N55 B30 A	498 500
X6 35 i (E71/72)	6	2979	225	01/2008	07/2014	N54 B30 A N55 B30 A	498 500
X6 35 i (E71/72)	6	2979	235	07/2009	06/2014	N55 B30 A	500
X6 35 i (F16/86)	6	2979	225	08/2014	07/2019	N55 B30 A	500
X6 35 i (F16/86)	6	2979	240	08/2014	07/2019	N55 B30 A	500
X6 40 d (E71/72)	6	2993	225	07/2009	06/2014	N57 D30 B	516
X6 40 d (F16/86)	6	2993	230	12/2014	07/2019	N57 D30 B	516
X6 40 d (G06)	6	2993	250	05/2020		B57 D30 B	506
X6 40 i (G06)	6	2998	250	08/2019		B58 B30 C	528
X6 40 i (G06)	6	2998	245	12/2020		B58 B30 C	528
X6 50 i (E71/72)	8	4395	330	10/2007	06/2014	N63 B44 A	546
X6 50 i (E71/72)	8	4395	300	07/2008	07/2014	N63 B44 A	546
X6 50 i (F16/86)	8	3982	300	08/2014	07/2019	N63 B40 A	542
X6 50 i (F16/86)	8	4395	330	08/2014	07/2019	N63 B44 B	548
X6 M (E71/72)	8	4395	414	07/2008	06/2014	S63 B44 A	550
X6 M (E71/72)	8	4395	408	07/2009	07/2014	S63 B44 A	550
X6 M (F16/86)	8	4395	423	12/2014	07/2019	S63 B44 B	552
X6 M (G06)	8	4395	441	12/2019		S63 B44 B	552
X6 M (G06)	8	4395	460	12/2019		S63 B44 B	552
X6 M 50 d (E71/72)	6	2993	280	08/2011	06/2014	N57 D30 C	518
X6 M 50 d (F16/86)	6	2993	280	08/2014	07/2019	N57 D30 C	518
X6 M50 d (G06)	6	2993	294	08/2019		B57 D30 C	506
X6 M50 i (G06)	8	4395	390	08/2019		N63 B44 D	550
X7 30 d (G07)	6	2993	155	03/2019	08/2020	B57 D30 A	504
X7 30 d (G07)	6	2993	183	03/2019		B57 D30 A	504
X7 30 d (G07)	6	2993	195	03/2019		B57 D30 A	504
X7 40 d (G07)	6	2993	155	03/2019		B57 D30 B	506
X7 40 d (G07)	6	2993	250	03/2019		B57 D30 B	506
X7 40 i (G07)	6	2998	250	03/2019		B58 B30 C	528
X7 40 i (G07)	6	2998	245	12/2020		B58 B30 C	528
X7 50 i (G07)	8	4395	340	03/2019		N63 B44 D	550

BMW		ccm	kW	→	→		
X7 M 50 d (G07)	6	2993	294	03/2019		B57 D30 C	506
X7 M50 i (G07)	8	4395	390	07/2019		N63 B44 D	550
Z1	6	2494	125	06/1988	06/1991	M20 B25 (256K1)	474
Z3 (E36)	4	1796	85	10/1995	10/1998	M43 B18 (184E2)	426
Z3 (E36)	4	1895	103	11/1995	03/1999	M44 B19 (194S1)	428
Z3 (E36)	4	1895	87	07/1998	01/2003	M43 B19 (194E1)	428
Z3 (E36)	4	1895	85	01/1999	01/2003	M43 B19 (194E1)	428
Z3 (E36)	6	1991	110	04/1999	01/2003	M52 B20 (206S4)	434
Z3 (E36)	6	2171	120	08/2000	01/2003	M54 B22 (226S1)	470
Z3 (E36)	6	2171	125	10/2000	06/2002	M54 B22 (226S1)	470
Z3 (E36)	6	2494	125	09/1998	09/2000	M52 B25 (256S4)	484
Z3 (E36)	6	2494	141	10/2000	08/2002	M54 B25 (256S5)	486
Z3 (E36)	6	2793	143	01/1996	07/2000	M52 B28 (286S1) M52 B28 (286S2)	494
Z3 (E36)	6	2793	142	11/1996	05/2000	M52 B28 (286S1) M52 B28 (286S2)	494
Z3 (E36)	6	2979	168	06/2000	12/2002	M54 B30 (306S3)	498
Z3 (E36)	6	2979	170	06/2000	06/2003	M54 B30 (306S3)	498
Z3 (E36)	6	3152	176	02/1998	06/2000	S52 B32 (326S2)	530
Z3 (E36)	6	3152	179	02/1998	06/2000	S52 B32 (326S2)	530
Z3 (E36)	6	3201	236	02/1998	06/2001	S50 B32 (326S1) S50 B32 (326S3)	532
Z3 (E36)	6	3246	235	09/2000	12/2002	S54 B32 (326S4)	532
Z3 M 3.2 (E36)	6	3201	236	01/1997	06/2000	S50 B32 (326S1)	532
Z3 M 3.2 (E36)	6	3246	235	09/2000	12/2002	S54 B32 (326S4)	532
Z3 M 3.2 (E36)	6	3246	239	06/2001	06/2003	S54 B32 (326S4)	532

BMW



BMW		ccm	kW	→	→		
Z4 18 i (E89)	4	1997	115	04/2013	08/2016	N20 B20 A	456
Z4 2.0 i (E85)	4	1995	110	03/2005	02/2009	N46 B20 B	446
Z4 2.2 i (E85)	6	2171	125	10/2003	10/2005	M54 B22 (226S1)	470
Z4 2.5 i (E85)	6	2494	141	12/2002	12/2005	M54 B25 (256S5)	486
Z4 2.5 i (E85)	6	2497	130	09/2005	02/2009	N52 B25 A	490
Z4 2.5 i (E85)	6	2497	155	09/2005	02/2009	N52 B25 A N52 B25 AF	490
Z4 2.5 i (E85)	6	2497	160	01/2006	08/2008	N52 B25 A	490
Z4 2.5 i (E86)	6	2494	141	11/2006	04/2008	M54 B25 (256S5)	486
Z4 20 i (E89)	4	1997	120	09/2011	08/2016	N20 B20 A	456
Z4 20 i (E89)	4	1997	135	09/2011	08/2016	N20 B20 A	456
Z4 20 i (G29)	4	1998	120	11/2018		B46 B20 B B48 B20 B	462 468
Z4 20 i (G29)	4	1998	145	11/2018		B46 B20 B B48 B20 B	462 468
Z4 23 i (E89)	6	2497	150	03/2009	08/2011	N52 B25 A N52 B25 BF	490
Z4 28 i (E89)	4	1997	180	09/2011	08/2016	N20 B20 A	456
Z4 3.0 i (E85)	6	2979	170	12/2002	12/2005	M54 B30 (306S3)	498
Z4 3.0 i (E85)	6	2996	160	09/2005	12/2008	N52 B30 A	520
Z4 3.0 i (E85)	6	2996	190	01/2006	08/2008	N52 B30 A N52 B30 BF	520
Z4 3.0 i (E85)	6	2996	195	01/2006	08/2008	N52 B30 A N52 B30 BF	520
Z4 3.0 i (E86)	6	2996	160	03/2006	01/2009	N52 B30 A	520
Z4 3.0 i (E86)	6	2996	190	03/2006	08/2008	N52 B30 A	520
Z4 3.0 i (E86)	6	2996	195	04/2006	08/2008	N52 B30 A N52 B30 BF	520
Z4 3.2 i (E85)	6	3246	235	09/2005	12/2007	S54 B32 (326S4)	532
Z4 30 i (E89)	6	2996	190	02/2009	08/2011	N52 B30 A N52 B30 B N52 B30 BF	520 522 520
Z4 30 i (E89)	6	2996	195	05/2009	08/2011	N52 B30 A	520
Z4 30 i (G29)	4	1998	190	11/2018		B46 B20 B B48 B20 B	462 468
Z4 35 i (E89)	6	2979	224	02/2009	08/2016	N54 B30 A	498
Z4 35 i (E89)	6	2979	225	02/2009	08/2016	N54 B30 A	498
Z4 35 is (E89)	6	2979	250	03/2010	08/2016	N54 B30 A	498
Z4 M 3.2 (E85)	6	3246	252	01/2006	08/2008	S54 B32 (326S4)	532

BMW		ccm	kW	→	→		
Z4 M 3.2 (E86)	6	3246	235	03/2006	12/2008	S54 B32 (326S4)	532
Z4 M 3.2 (E86)	6	3246	252	04/2006	08/2008	S54 B32 (326S4)	532
Z4 M 40 i (G29)	6	2998	250	11/2018		B58 B30 C	528
Z4 M 40 i (G29)	6	2998	285	03/2019		B58 B30 B	528
Z8 (E52)	8	4941	294	01/2000	12/2003	S62 B50 (508S1)	562

BMW



Das Original



B32 S15 A	3	1499	410
B37 C15 A	3	1496	408
B37 D15 A	3	1496	408
B38 A15 A	3	1499	410
B38 A15 C	3	1499	410
B38 B15 A	3	1499	412
B38 K15 A	3	1499	412
B42 S20 A	4	1998	460
B46 A20 B	4	1998	460
B46 B20 B	4	1998	462
B47 C20 A	4	1995	436
B47 C20 B	4	1995	438
B47 D20 A	4	1995	440
B47 D20 B	4	1995	442
B48 A20 A	4	1998	462
B48 A20 B	4	1998	464
B48 A20 C	4	1998	464
B48 B16 A	4	1597	418
B48 B20 A	4	1998	466
B48 B20 B	4	1998	468
B57 D30 A	6	2993	504
B57 D30 B	6	2993	506
B57 D30 C	6	2993	506
B58 B30 A	6	2998	526
B58 B30 B	6	2998	528
B58 B30 C	6	2998	528
M10 B18 (184EA)	4	1766	422
M10 B18 (184EB)	4	1766	422
M10 B18 (184EW)	4	1766	422
M10 B18 (184EY)	4	1766	422
M10 B18 (184EZ)	4	1766	422
M10 B18 (184KA)	4	1766	422
M10 B18 (184VA)	4	1766	424

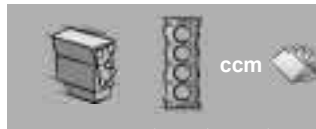

M10 B18 (184VU)	4	1766	422
M20 B20	6	1990	430
M20 B20 (206EA)	6	1990	430
M20 B20 (206EB)	6	1990	430
M20 B20 (206EC)	6	1990	430
M20 B20 (206EE)	6	1990	430
M20 B20 (206EY)	6	1990	430
M20 B20 (206EZ)	6	1990	430
M20 B20 (206KA)	6	1990	430
M20 B20 (206VA)	6	1990	430
M20 B23 (236EA)	6	2316	472
M20 B23 (236EB)	6	2316	472
M20 B23 (236EC)	6	2316	472
M20 B23 (236EW)	6	2316	472
M20 B25 (256E1)	6	2494	474
M20 B25 (256E2)	6	2494	474
M20 B25 (256EX)	6	2494	474
M20 B25 (256K1)	6	2494	474
M20 B27 (276EA)	6	2693	492
M20 B27 (276EB)	6	2693	492
M20 B27 (276KA)	6	2693	492
M20 B27 (276KB)	6	2693	492
M21 D24 (246DA)	6	2443	472
M21 D24 (246DB)	6	2443	472
M21 D24 (246TA)	6	2443	474



M21 D24 (246TB)	6	2443	474
M21 D24 W	6	2443	472
M30 B25	6	2494	474
M30 B25 (256EA)	6	2494	474
M30 B25 (256VA)	6	2494	474
M30 B25 A	6	2494	474
M30 B34 (346EA)	6	3430	534
M30 B34 (346EC)	6	3430	534
M30 B34 (346KA)	6	3430	534
M30 B34 (346KB)	6	3430	534
M30 B34 (346TA)	6	3430	534
M30 B35 (346EC)	6	3453	536
M30 B35 (356EA)	6	3453	536
M30 B35 (L-Jetronic, 10:1)	6	3453	536
M30 B35 (Motronic, 10:1)	6	3430	534
M30 B35 (Motronic, 9.2:1)	6	3430	536
M40 B16	4	1596	414
M40 B16 (164E1)	4	1596	414
M40 B18 (184E1)	4	1796	424
M41 D17 (174T1)	4	1665	420
M42 B18 (184S1)	4	1796	426
M43 B16 (164E2)	4	1596	416
M43 B16 (164E3)	4	1596	416
M43 B18 (184E2)	4	1796	426
M43 B19 (194E1)	4	1895	428
M44 B19 (194S1)	4	1895	428

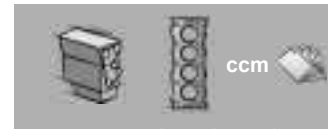

M47 D20 (204D1)	4	1951	430
M47 D20 (204D4)	4	1995	444
M50 B20 (206S1)	6	1990	432
M50 B20 (206S2)	6	1990	432
M50 B25 (256S1)	6	2494	476
M50 B25 (256S2)	6	2494	478
M51 D25 (256T1)	6	2497	488
M52 B20 (206S3)	6	1990	434
M52 B20 (206S4)	6	1990	434
M52 B25 (256S3)	6	2494	480
M52 B25 (256S4)	6	2494	484
M52 B28 (286S1)	6	2793	494
M52 B28 (286S2)	6	2793	494
M54 B22 (226S1)	6	2171	470
M54 B25 (256S3)	6	2494	486
M54 B25 (256S5)	6	2494	486
M54 B30 (306S3)	6	2979	498
M57 D25 (256D1)	6	2497	488
M57 D25 (256D2)	6	2497	488
M57 D30 (306D1)	6	2926	496
M57 D30 (306D2)	6	2993	508
M57 D30 (306D3)	6	2993	510
M57 D30 (306D4)	6	2993	512
M57 D30 (306D5)	6	2993	512
M60 B30	8	2997	526



M60 B30 (308S1)	8	2997	526
M60 B40 (408S1)	8	3982	540
M62 B35 (358S1)	8	3498	538
M62 B35 (358S2)	8	3498	538
M62 B35 TU	8	3498	538
M62 B44 (448S1)	8	4398	554
M62 B44 (448S2)	8	4398	556
M62 B46 (468S1)	8	4619	558
M70 B50 (5012A)	12	4988	562
M70 B56	12	5576	564
M73 B54	12	5379	564
M73 B54 (54121)	12	5379	564
M73 B54 (54122)	12	5379	564
N13 B16 A	4	1598	418
N20 B16 A	4	1592	414
N20 B20 A	4	1997	456
N20 B20 B	4	1997	456
N20 B20 C	4	1997	456
N20 B20 D	4	1997	456
N26 B20 A	4	1997	458
N40 B16 A	4	1596	416
N42 B18 A	4	1796	428
N42 B20	4	1995	444
N42 B20 A	4	1995	444
N42 B20 B	4	1995	444
N43 B16 A	4	1599	420
N43 B16 AA	4	1599	420
N43 B20 A	4	1995	444
N45 B16	4	1596	418
N45 B16 A	4	1596	418
N45 B16 AC	4	1596	418
N45 B20 A	4	1997	458













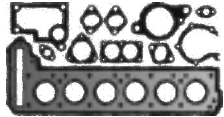
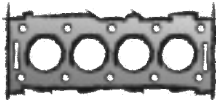

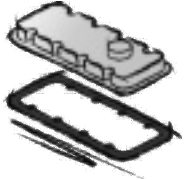
N46 B18 A	4	1796	428
N46 B20 A	4	1995	446
N46 B20 B	4	1995	446
N46 B20 BD	4	1995	448
N46 B20 C	4	1995	448
N46 B20 CB	4	1995	448
N46 B20 CC	4	1995	448
N46 B20 CD	4	1995	448
N46 B20 E	4	1995	448
N47 D16 A	4	1598	420
N47 D20 A	4	1995	448
N47 D20 B	4	1995	450
N47 D20 C	4	1995	452
N47 D20 D	4	1995	454
N51 B30 A	6	2996	518
N52 B25	6	2497	490
N52 B25 A	6	2497	490
N52 B25 AE	6	2497	490
N52 B25 AF	6	2497	490
N52 B25 B	6	2497	490
N52 B25 BE	6	2497	490
N52 B25 BF	6	2497	490
N52 B25 C	6	2497	490
N52 B30	6	2996	520
N52 B30 A	6	2996	520
N52 B30 AE	6	2996	520
N52 B30 AF	6	2996	522
N52 B30 B	6	2996	522
N52 B30 BF	6	2996	520
N53 B25 A	6	2497	492
N53 B30	6	2996	524
N53 B30 A	6	2996	524
N54 B30 A	6	2979	498
N54 B30 B	6	2979	498
N55 B30 A	6	2979	500
N57 D30 A	6	2993	514
N57 D30 B	6	2993	516



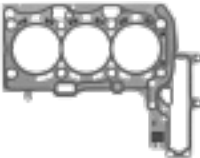
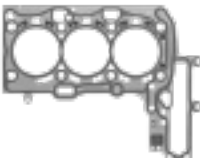



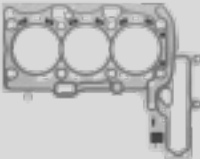
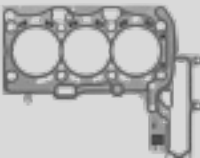
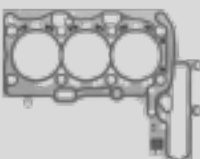



















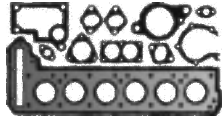
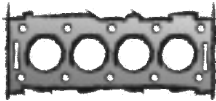

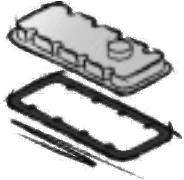



N57 D30 C	6	2993	518
N62 B36 A	8	3600	540
N62 B40 A	8	4000	544
N62 B44 A	8	4398	558
N62 B48 A	8	4799	560
N62 B48 B	8	4799	560
N63 B40 A	8	3982	542
N63 B44 A	8	4395	546
N63 B44 B	8	4395	548
N63 B44 C	8	4395	548
N63 B44 D	8	4395	550
S14 204 EA	4	1990	436
S14 B20 (204EA)	4	1990	436
S14 B23 (234EA)	4	2302	470
S14 B23 (234S1)	4	2302	470
S14 B23 (234S2)	4	2302	470
S14 B23 (EVO I)	4	2302	470
S50 B30 (306S1)	6	2990	502
S50 B30 (306S2)	6	2990	502
S50 B32	6	3201	532
S50 B32 (326S1)	6	3201	532
S50 B32 (326S3)	6	3201	532
S52 B32	6	3152	530
S52 B32 (326S2)	6	3152	530
S54 B32 (326S4)	6	3246	532
S55 B30 A	6	2979	500
S62 B50 (508S1)	8	4941	562
S63 B44 A	8	4395	550
S63 B44 B	8	4395	552
S65 B40 A	8	3999	542
S70 B56 (56121)	12	5576	564























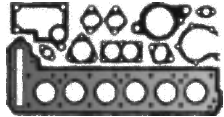
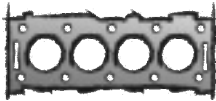

S85 B50 A	10	4999	562
W20K06A	2	647	408

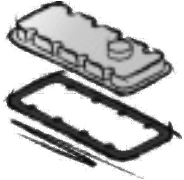





BMW 				
W20K06A 2 Cyl. 647 ccm Cyl. 79,0 Ø i3 08/2013 →	S⊕* 444.930	784.950 11 12 7 729 541 0,50 mm $\frac{\pm}{\pm}$ 81 Ø		ZKHS 795.330 11 12 8 551 906
B37 C15 A 3 Cyl. 1496 ccm Cyl. 84,0 Ø 116 d (F40) 07/2019 → 214 d (F45/46) 07/2014 → 02/2018 216 d (F44) 03/2020 → 216 d (F45/46) 03/2014 → X1 16 d (F84) 11/2014 → X2 16 d (F39) 11/2018 →	ES 648.050  CS 648.080 OKS 582.190 11 42 8 591 461 	597.110 11 12 8 511 227 0,98 mm $\frac{\pm}{\pm}$ 84 Ø 1 ⊗  597.120 11 12 8 511 228 1,08 mm $\frac{\pm}{\pm}$ 84 Ø 2 ⊗  597.130 11 12 8 511 229 1,18 mm $\frac{\pm}{\pm}$ 84 Ø 3 ⊗ 	ZKS 593.520 11 12 8 511 621 (8x) M 12x1,5x200 	ZKHS 449.650 11 12 8 583 292 
B37 D15 A 3 Cyl. 1496 ccm Cyl. 84,0 Ø 114 d (F20/21) 06/2015 → 116 d (F20/21) 03/2015 →	ES 648.050  CS 648.080 OKS 634.970 11 42 8 591 462 	597.110 11 12 8 511 227 0,98 mm $\frac{\pm}{\pm}$ 84 Ø 1 ⊗  597.120 11 12 8 511 228 1,08 mm $\frac{\pm}{\pm}$ 84 Ø 2 ⊗  597.130 11 12 8 511 229 1,18 mm $\frac{\pm}{\pm}$ 84 Ø 3 ⊗ 	ZKS 593.520 11 12 8 511 621 (8x) M 12x1,5x200 	ZKHS 449.650 11 12 8 583 292 

			<p>a) </p> <p>b) </p>	<p>K: </p> <p>N: </p>	
<p>VAS 702.460 FPM</p>			<p>a) 036.164 11 12 1 262 571 Dirko HT / EU</p> <p>a) 510.031 11 12 1 262 571 Dirko HT / USA/CDN/MEX</p> <p>a) 527.291 11 12 1 262 571 Dirko HT / RU</p> <p>a) 648.661 11 12 1 262 571 Dirko HT / BR</p>	<p>K:→ 703.550 11 14 8 544 855 ASW LD FPM 54x70x8</p>	
<p>VAS 530.070 11 34 7 807 347</p> <p>539.420 FPM 12x</p>	<p>077.382 11 62 8 511 758</p> 	<p>593.390 11 61 8 571 001 3x</p> 	<p>a) 036.164 11 12 1 262 571 Dirko HT / EU</p> <p>a) 510.031 11 12 1 262 571 Dirko HT / USA/CDN/MEX</p> <p>a) 527.291 11 12 1 262 571 Dirko HT / RU</p> <p>a) 648.661 11 12 1 262 571 Dirko HT / BR</p> <p>b) 455.740 11 13 7 535 106 +07 11 9 963 151 M 12x1,5x16</p> <p>b) 110.507 07 11 9 963 132 CU A 12x16x1</p>	<p>K:→ 492.060 11 14 7 797 490 AW/BS OF LD FPM 90x104x9</p>	<p>TLS 568.870</p> 
<p>VAS 530.070 11 34 7 807 347</p> <p>539.420 FPM 12x</p>	<p>077.382 11 62 8 511 758</p> 	<p>593.390 11 61 8 571 001 3x</p> 	<p>a) 036.164 11 12 1 262 571 Dirko HT / EU</p> <p>a) 510.031 11 12 1 262 571 Dirko HT / USA/CDN/MEX</p> <p>a) 527.291 11 12 1 262 571 Dirko HT / RU</p> <p>a) 648.661 11 12 1 262 571 Dirko HT / BR</p> <p>b) 455.740 11 13 7 535 106 +07 11 9 963 151 M 12x1,5x16</p> <p>b) 110.507 07 11 9 963 132 CU A 12x16x1</p>	<p>K:→ 492.060 11 14 7 797 490 AW/BS OF LD FPM 90x104x9</p>	<p>TLS 568.870</p> 

BMW 				
B32 S15 A 3 Cyl. 1499 ccm Cyl. 82,0 Ø X2 18 i (F39) 03/2018 →	ES 648.620  CS 702.520 OKS 582.190 11 42 8 591 461 		ZKS 572.630 11 12 8 644 674 (8x) M 11x188 	588.340 11 12 8 618 515 
B38 A15 A 3 Cyl. 1499 ccm Cyl. 82,0 Ø 116 i (F40) 11/2020 → 118 i (F40) 07/2019 → 216 i (F45/46) 09/2014 → 218 i (F44) 11/2019 → 218 i (F45/46) 07/2014 → 225 xe (F45/46) 11/2014 → X1 18 i (F48) 11/2015 → X1 25 e (F48) 03/2020 → X2 18 i (F39) 03/2018 → X2 25 e (F39) 03/2020 →	ES 793.120 225 xe F45   ES 648.620 F45 2X71/72 F45 2A31/32 F48 HS11/12 F46 2D31/32 F39  CS 702.520 OKS 582.190 11 42 8 591 461 		ZKS 572.630 11 12 8 644 674 (8x) M 11x188 	588.340 11 12 8 618 515 F45 2A31/32 F46 2D31/32 F45 2X71/72 F48 HS11/12 F39 
B38 A15 C 3 Cyl. 1499 ccm Cyl. 82,0 Ø 118 i (F52) 01/2017 → 08/2019	CS 702.520 OKS 582.190 11 42 8 591 461 		ZKS 572.630 11 12 8 644 674 (8x) M 11x188 	588.340 11 12 8 618 515 

			<p>a) </p> <p>b) </p>	<p>K: </p> <p>N: </p>	
<p>VAS 308.970 11 34 0 038 719 FPM E</p> <p>VAS 308.630 11 34 0 038 720 FPM A</p>	<p>077.363 11 65 7 618 035</p> 	<p>572.700 11 61 7 633 493 3x</p>	<p>a) 036.164 11 12 1 262 571 Dirko HT / EU</p> <p>a) 510.031 11 12 1 262 571 Dirko HT / USA/CDN/MEX</p> <p>a) 527.291 11 12 1 262 571 Dirko HT / RU</p> <p>a) 648.661 11 12 1 262 571 Dirko HT / BR</p> <p>b) 455.740 11 13 7 535 106 +07 11 9 963 151 M 12x1,5x16</p> <p>b) 110.507 07 11 9 963 132 CU A 12x16x1</p>	<p>K:→ 586.550 11 14 8 602 594 ASW LD PTFE 90x104x8,5</p>	<p>TLS 648.640</p>
<p>VAS 308.970 11 34 0 038 719 FPM E</p> <p>VAS 308.630 11 34 0 038 720 FPM A</p>	<p>077.363 11 65 7 618 035 F48 HS11/12 F46 2D31/32 F45 2X71/72 F45 2A31/32 F39</p>  <p>077.402 ● 11 62 7 625 167 225 xe F45 Euro 6 RDE</p> <p>077.413 11 62 8 607 013 225 xe F45</p>  <p>586.331 11 65 8 631 699 F45 2X91/92 F45 6S11/12 F48 JG11/12 F46 6V31/32 F39</p>	<p>572.700 11 61 7 633 493 3x</p>	<p>a) 036.164 11 12 1 262 571 Dirko HT / EU</p> <p>a) 510.031 11 12 1 262 571 Dirko HT / USA/CDN/MEX</p> <p>a) 527.291 11 12 1 262 571 Dirko HT / RU</p> <p>a) 648.661 11 12 1 262 571 Dirko HT / BR</p> <p>b) 455.740 11 13 7 535 106 +07 11 9 963 151 M 12x1,5x16</p> <p>b) 110.507 07 11 9 963 132 CU A 12x16x1</p>	<p>K:→ 586.550 11 14 8 602 594 ASW LD PTFE 90x104x8,5</p>	<p>TLS 648.640 F48 HS11/12 F45 2A31/32 F46 2D31/32 F45 2X71/72 F39</p>
<p>VAS 308.970 11 34 0 038 719 FPM E</p> <p>VAS 308.630 11 34 0 038 720 FPM A</p>	<p>077.363 11 65 7 618 035</p> 		<p>a) 036.164 11 12 1 262 571 Dirko HT / EU</p> <p>a) 510.031 11 12 1 262 571 Dirko HT / USA/CDN/MEX</p> <p>a) 527.291 11 12 1 262 571 Dirko HT / RU</p> <p>a) 648.661 11 12 1 262 571 Dirko HT / BR</p> <p>b) 455.740 11 13 7 535 106 +07 11 9 963 151 M 12x1,5x16</p> <p>b) 110.507 07 11 9 963 132 CU A 12x16x1</p>	<p>K:→ 586.550 11 14 8 602 594 ASW LD PTFE 90x104x8,5</p>	<p>TLS 648.640</p>

<p>BMW</p> 				
<p>B38 B15 A</p> <p>3 Cyl. 1499 ccm Cyl. 82,0 Ø</p> <p>116 i (F20/21) 03/2015 →</p> <p>118 i (F20/21) 03/2015 →</p> <p>218 i (F22/23) 03/2015 →</p> <p>220 i (F22/23) 10/2017 →</p> <p>318 i (F30/31/35) 07/2015 → 06/2019</p> <p>418 i (F32/33/36/82/83) 07/2015 →</p>	<p>ES 648.620</p>  <p>CS 702.530</p> <p>OKS 634.970 11 42 8 591 462</p> 		<p>ZKS 572.630 11 12 8 644 674 (8x) M 11x188</p> 	<p>588.340 11 12 8 618 515</p> 
<p>B38 K15 A</p> <p>3 Cyl. 1499 ccm Cyl. 82,0 Ø</p> <p>i8 03/2014 → 06/2020</p>	<p>ES⊕ 481.940 Euro 6 RDE</p>  <p>CS 702.520</p> <p>OKS 582.190 11 42 8 591 461</p> 		<p>ZKS 572.630 11 12 8 644 674 (8x) M 11x188</p> 	<p>588.340 11 12 8 618 515</p> 

			<p>a) </p> <p>b) </p>	<p>K: </p> <p>N: </p>	
<p>VAS 308.970 11 34 0 038 719 FPM E</p> <p>VAS 308.630 11 34 0 038 720 FPM A</p>	<p>077.363 11 65 7 618 035</p> 		<p>a) 036.164 11 12 1 262 571 Dirko HT / EU</p> <p>a) 510.031 11 12 1 262 571 Dirko HT / USA/CDN/MEX</p> <p>a) 527.291 11 12 1 262 571 Dirko HT / RU</p> <p>a) 648.661 11 12 1 262 571 Dirko HT / BR</p> <p>b) 455.740 11 13 7 535 106 +07 11 9 963 151 M 12x1,5x16</p> <p>b) 110.507 07 11 9 963 132 CU A 12x16x1</p>	<p>K:→ 586.550 11 14 8 602 594 ASW LD PTFE 90x104x8,5</p>	<p>TLS 648.640</p>
<p>VAS 308.970 11 34 0 038 719 FPM E</p> <p>VAS 308.630 11 34 0 038 720 FPM A</p>	<p>077.402 ● 11 62 7 625 167 Euro 6 RDE</p>		<p>a) 036.164 11 12 1 262 571 Dirko HT / EU</p> <p>a) 510.031 11 12 1 262 571 Dirko HT / USA/CDN/MEX</p> <p>a) 527.291 11 12 1 262 571 Dirko HT / RU</p> <p>a) 648.661 11 12 1 262 571 Dirko HT / BR</p> <p>b) 455.740 11 13 7 535 106 +07 11 9 963 151 M 12x1,5x16</p> <p>b) 110.507 07 11 9 963 132 CU A 12x16x1</p>	<p>K:→ 586.550 11 14 8 602 594 ASW LD PTFE 90x104x8,5</p>	

BMW

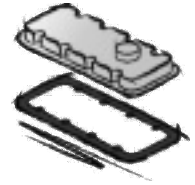
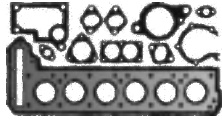

N20 B16 A

4 Cyl. **1592 ccm**
Cyl. 84,0 Ø

520 i (F10/11/18)
07/2013 → 10/2016
X1 16 i (E84)
03/2013 → 06/2015
X3 18 i (F25)
04/2014 → 08/2017

ES⊕ **522.190**



CS* **793.020**



AL

CS* **389.700**



PLASTIC

364.525

11 12 7 620 697
0,70 mm $\frac{\pm}{\text{mm}}$ 85,1 Ø

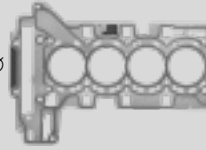

722.503

11 12 7 620 698
1,00 mm $\frac{\pm}{\text{mm}}$ 85,1 Ø

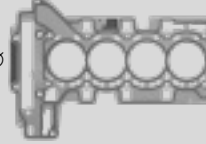

ZKS **426.890**

11 12 2 212 157
M 10x173 M 11x173
M9x30/70



ZKHS **054.930**

11 12 7 588 418



655.581

11 12 7 589 830
2x



M40 B16
M40 B16 (164E1)

4 Cyl. **1596 ccm**
Cyl. 84,0 Ø

316 i (E30)
09/1987 → 06/1994
316 i (E36)
03/1991 → 08/1993

ES⊕ **444.310**

incl. 888.986
11 12 0 007 611

ES⊕ **748.995**

11 12 9 059 241

CS* **817.430**

11 11 9 059 257
E30

CS* **893.749**

11 11 1 734 268
E36

888.979

11 12 7 504 586
1,74 mm $\frac{\pm}{\text{mm}}$ 85 Ø

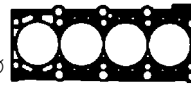

888.986

11 12 7 504 587
2,04 mm $\frac{\pm}{\text{mm}}$ 85 Ø

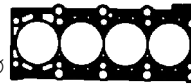

ZKS **802.760**



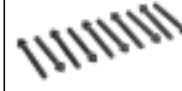











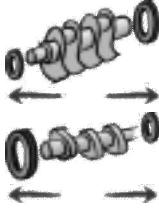



11 12 1 721 939
M 10x1,5x95











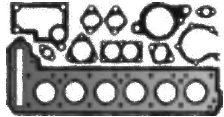
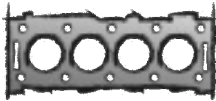

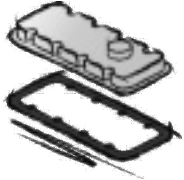



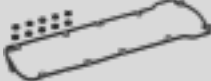
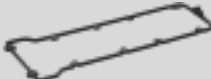



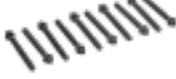





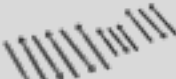









703.532

11 12 1 727 726











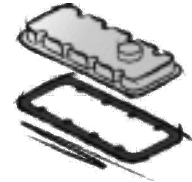
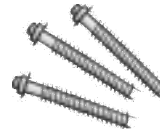
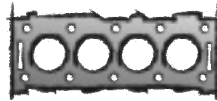
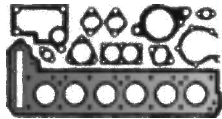







			<p>a) </p> <p>b) </p>	<p>K: </p> <p>N: </p>	
<p>VAS 308.970 11 34 0 038 719 FPM E</p> <p>VAS 308.630 11 34 0 038 720 FPM A</p>	<p>738.832 11 65 7 625 293 4x</p> 	<p>AAS 008.430 11 61 2 212 759</p> 	<p>a) 655.881 11 13 7 627 511</p>  <p>AL</p>  <p>a) 232.860 11 13 7 627 512</p>  <p>PLASTIC</p>  <p>b) 642.110 PP/ACM 11 13 7 605 018</p>  <p>PLASTIC</p> <p>b) 110.906 07 11 9 963 151 CU A 12x17x1,5</p>	<p>K:← 902.860 11 11 8 618 864 ASW RD PTFE/ACM 65x79x10</p> <p>K:→ 751.610 11 11 7 587 168 AW OF LD FPM 90x110x8</p>	<p>TLS 306.350</p> 
<p>VAS 825.042 11 34 9 059 171 FPM</p> <p>701.289 11 34 1 706 707 FPM 8x</p>	<p>267.840 11 62 1 743 719</p>	<p>670.780 11 61 1 734 683</p> 	<p>a) 762.033 11 13 1 739 592 ↑</p>  <p>a) 693.057 11 13 1 709 815 E30</p>  <p>b) 774.390 11 13 1 273 093 M 12x1,5x18</p> <p>b) 238.708 07 11 9 963 130 AL A 12x15,5x1,5</p>	<p>K:← 748.889 11 14 1 714 617 A/BS RD FPM 42x52x7,5</p> <p>K:→ 301.870 11 14 2 249 533 A/BS LD PTFE/FPM 90x110x12</p> <p>K:→ 702.994 11 14 1 706 999 A/BS LD FPM 90x110x12</p> <p>N:← 586.668 11 12 1 285 609 ASW WD FPM 38x50x7</p>	

BMW 				
M43 B16 (164E2) 4 Cyl. 1596 ccm Cyl. 84,0 Ø 316 g (E36) 02/1996 → 08/2000 316 i (E36) 09/1993 → 08/2000	ES⊕ 444.320 incl. 888.986 11 12 9 066 452 →01/1996 ES⊕ 495.800 11 12 9 066 452 →01/1996 ES⊕ 366.070 11 12 0 007 610 02/1996→ ES⊕ 444.330 incl. 888.986 11 12 0 007 610 02/1996→ CS* 423.980 11 11 9 066 453	888.979 11 12 7 504 586 1,74 mm $\frac{\pm}{\text{mm}}$ 85 Ø  888.986 11 12 7 504 587 2,04 mm $\frac{\pm}{\text{mm}}$ 85 Ø 	ZKS 802.760 11 12 1 721 939 M 10x1,5x95 	ZKHS 040.060 11 12 1 432 885 +11 12 1 721 879 (10x)  422.370 11 12 1 432 885  767.891 11 12 1 721 879 10x 
M43 B16 (164E3) 4 Cyl. 1596 ccm Cyl. 84,0 Ø 316 Ci (E46) 04/2000 → 07/2006 316 i (E46) 04/2000 → 02/2005	ES⊕ 366.090 11 12 0 007 612 CS* 374.710 11 11 1 712 981	888.979 11 12 7 504 586 1,74 mm $\frac{\pm}{\text{mm}}$ 85 Ø  888.986 11 12 7 504 587 2,04 mm $\frac{\pm}{\text{mm}}$ 85 Ø 	ZKS 802.760 11 12 1 721 939 M 10x1,5x95 	ZKHS 040.060 11 12 1 432 885 +11 12 1 721 879 (10x)  422.370 11 12 1 432 885  767.891 11 12 1 721 879 10x 
N40 B16 A 4 Cyl. 1596 ccm Cyl. 84,0 Ø 316 (E46) 06/2002 → 02/2005 316 i (E46) 06/2002 → 02/2005 316 ti (E46) 06/2002 → 02/2005	ES⊕ 458.380 11 12 0 143 667  CS* 458.400 11 11 7 511 529	746.902 11 12 7 509 710 0,40 mm $\frac{\pm}{\text{mm}}$ 84,5 Ø  024.352 11 12 7 509 711 0,70 mm $\frac{\pm}{\text{mm}}$ 84,5 Ø 	ZKS 010.230 11 12 7 511 534 M 10x1,5x170 M 8x1,25x95/125 	ZKHS 448.520 11 12 0 031 987 

			<p>a) </p> <p>b) </p>	<p>K: </p> <p>N: </p>	
<p>VAS 825.042 11 34 9 059 171 FPM</p> <p>701.289 11 34 1 706 707 FPM 8x</p>	<p>267.840 11 62 1 743 719</p>	<p>670.780 11 61 1 734 683</p> 	<p>a) 762.033 11 13 1 739 592 →09/1995</p>  <p>a) 215.190 11 13 1 739 813 09/1995→</p>  <p>b) 774.390 11 13 1 273 093 M 12x1,5x18</p> <p>b) 238.708 07 11 9 963 130 AL A 12x15,5x1,5</p>	<p>K:← 214.680 11 14 1 439 570 AW/BS RD PTFE/ACM 44x60x10</p> <p>K:← 761.796 11 14 1 721 560 AW/BS RD FPM 44x60x10</p> <p>K:→ 301.870 11 14 2 249 533 A/BS LD PTFE/FPM 90x110x12</p> <p>K:→ 702.994 11 14 1 706 999 A/BS LD FPM 90x110x12</p>	
<p>VAS 825.042 11 34 9 059 171 FPM</p> <p>701.289 11 34 1 706 707 FPM 8x</p>	<p>267.840 11 62 1 743 719</p>	<p>359.370 11 61 1 437 384 4x</p> 	<p>a) 373.160 11 13 1 432 109</p>  <p>b) 774.390 11 13 1 273 093 M 12x1,5x18</p> <p>b) 238.708 07 11 9 963 130 AL A 12x15,5x1,5</p>	<p>K:← 214.680 11 14 1 439 570 AW/BS RD PTFE/ACM 44x60x10</p> <p>K:← 761.796 11 14 1 721 560 AW/BS RD FPM 44x60x10</p> <p>K:→ 301.870 11 14 2 249 533 A/BS LD PTFE/FPM 90x110x12</p> <p>K:→ 702.994 11 14 1 706 999 A/BS LD FPM 90x110x12</p>	
<p>VAS 199.440 11 34 0 029 751 FPM</p> <p>198.770 11 34 7 505 417 FPM 16x</p>	<p>438.820 18 30 7 540 797</p> 	<p>AAS 445.130 11 61 7 530 703</p> 	<p>a) 190.640 11 13 7 511 224</p>  <p>b) 877.940 11 13 7 568 309 +07 11 9 963 150 M 12x1,5x10</p> <p>b) 068.616 07 11 9 963 150 AL A 12x17x1,5</p> <p>b) 110.906 07 11 9 963 151 CU A 12x17x1,5</p>	<p>K:← 257.400 11 11 7 511 395 ASW RD PTFE/ACM 65x79x20</p> <p>K:→ 257.770 11 11 7 511 396 ASW LD PTFE/ACM 90x110x12</p>	

BMW



			<p>a) </p> <p>b) </p>	<p>K: </p> <p>N: </p>	
<p>VAS 199.440 11 34 0 029 751 FPM</p> <p>198.770 11 34 7 505 417 FPM 16x</p>	<p>438.820 18 30 7 540 797</p> 	<p>AAS 445.130 11 61 7 530 703 E46</p>  <p>AAS 457.430 11 61 7 528 584 E81/87 E90</p> 	<p>a) 190.640 11 13 7 511 224</p>  <p>b) 877.940 11 13 7 568 309 +07 11 9 963 150 M 12x1,5x10</p> <p>b) 068.616 07 11 9 963 150 AL A 12x17x1,5</p> <p>b) 110.906 07 11 9 963 151 CU A 12x17x1,5</p>	<p>K:← 257.400 11 11 7 511 395 ASW RD PTFE/ACM 65x79x20</p> <p>K:→ 257.770 11 11 7 511 396 ASW LD PTFE/ACM 90x110x12</p>	
<p>VAS 308.970 11 34 0 038 719 FPM →06/2015 2x</p> <hr/> <p>06/2015→ E 1x</p> <p>VAS 308.630 11 34 0 038 720 FPM 06/2015→ A 1x</p>	<p>077.394 11 62 7 617 523</p> 		<p>a) 036.164 11 12 1 262 571 Dirko HT / EU</p> <p>a) 510.031 11 12 1 262 571 Dirko HT / USA/CDN/MEX</p> <p>a) 527.291 11 12 1 262 571 Dirko HT / RU</p> <p>a) 648.661 11 12 1 262 571 Dirko HT / BR</p> <p>b) 455.740 11 13 7 535 106 +07 11 9 963 151 M 12x1,5x16</p> <p>b) 110.507 07 11 9 963 132 CU A 12x16x1</p>	<p>K:← 575.970 11 11 8 604 931 ASW RD PTFE/ACM 55x68x8</p> <p>K:→ 586.550 11 14 8 602 594 ASW LD PTFE 90x104x8,5</p>	<p>TLS 085.550</p>
<p>VAS 747.210 11 34 0 033 950 FPM</p>		<p>AAS 893.650</p> 	<p>a) 036.164 11 12 1 262 571 Dirko HT / EU</p> <p>a) 510.031 11 12 1 262 571 Dirko HT / USA/CDN/MEX</p> <p>a) 527.291 11 12 1 262 571 Dirko HT / RU</p> <p>a) 648.661 11 12 1 262 571 Dirko HT / BR</p> <p>b) 877.870 07 11 9 905 428 +07 11 9 963 308 M 18x1,5x12</p> <p>b) 122.505 07 11 9 963 308 CU A 18x22x1,5</p>	<p>K:← 004.450 11 11 7 568 264 ASW RD PTFE/ACM 61x75x8</p> <p>K:→ 369.470 11 11 7 568 263 ASW LD PTFE/ACM 85x105x8</p>	<p>TLS 582.000</p> 

BMW

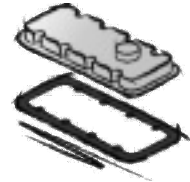
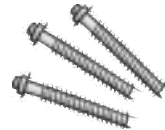
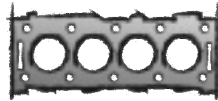
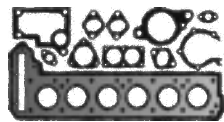

N47 D16 A

4 Cyl. 1598 ccm
Cyl. 78,0 Ø

114 d (F20/21)

07/2012 →

116 d (F20/21)

12/2011 →

CS* 376.500

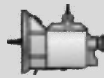

138.111

11 12 8 509 149

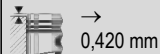

0,420 mm

0,95 mm $\frac{\pm}{\pm}$ 78,7 Ø

1 ⊗

138.121

11 12 8 509 150

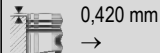

0,420 mm

0,530 mm

1,05 mm $\frac{\pm}{\pm}$ 78,7 Ø

2 ⊗

138.131

11 12 8 509 151

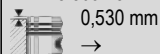

0,530 mm

0,680 mm

1,15 mm $\frac{\pm}{\pm}$ 78,7 Ø

3 ⊗

ZKS 233.370

11 12 8 511 621 (10x)

M 12x1,5x200



ZKHS 249.750

11 12 8 511 814

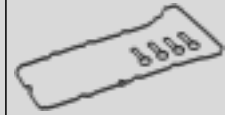

N43 B16 A/AA

4 Cyl. 1599 ccm
Cyl. 82,0 Ø

116 i (E81/87)

03/2007 → 12/2011

316 i (E90/91/92/93)

09/2007 → 06/2013

ES⊕ 727.751



CS* 458.400

11 11 7 511 529

353.273

11 12 7 563 413

0,47 mm $\frac{\pm}{\pm}$ 82,8 Ø



353.301

11 12 7 578 094

0,78 mm $\frac{\pm}{\pm}$ 82,8 Ø



ZKS 527.450

11 12 7 578 077

M 10x1,5x170

M9x1,25x95/125



ZKHS 649.880



724.470

11 12 7 555 738



M41 D17 (174T1)

4 Cyl. 1665 ccm
Cyl. 80,0 Ø

318 td (E36)

01/1995 → 08/2000

ES⊕ 425.140

11 12 2 246 704



CS* 445.250 ●

11 11 2 246 703

425.150

11 12 2 246 093

1,68 mm $\frac{\pm}{\pm}$ 81 Ø

2 ▽

425.170

11 12 2 246 092

1,87 mm $\frac{\pm}{\pm}$ 81 Ø

3 ▽



ZKS 802.661

11 12 9 067 792



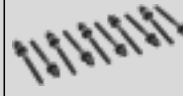















M 12x1,5x147



501.042

11 12 2 245 599



			<p>a) </p> <p>b) </p>	<p>K: </p> <p>N: </p>	
<p>VAS 530.070 11 34 7 807 347 539.420 FPM 16x</p>	<p>503.721 11 62 7 811 221 2x </p>		<p>a) 030.793 Dirko HT</p> <p>b) 455.740 11 13 7 535 106 +07 11 9 963 151 M 12x1,5x16</p> <p>b) 110.906 07 11 9 963 151 CU A 12x17x1,5</p>	<p>K:← 584.160 11 11 7 802 665 AW/BS OF RD FPM 55x68x8</p> <p>K:→ 492.060 11 14 7 797 490 AW/BS OF LD FPM 90x104x9</p>	<p>TLS 456.100 </p>
<p>VAS 715.550 11 34 0 035 888 FPM</p>	<p>504.380 18 40 7 530 606 4x </p>	<p>AAS 727.730 11 61 7 546 983</p> <p></p> <p>727.720 11 61 7 546 983 4x </p>	<p>a) 190.640 11 13 7 511 224 </p> <p>b) 877.940 11 13 7 568 309 +07 11 9 963 150 M 12x1,5x10</p> <p>b) 068.616 07 11 9 963 150 AL A 12x17x1,5</p> <p>b) 110.906 07 11 9 963 151 CU A 12x17x1,5</p>	<p>K:← 257.400 11 11 7 511 395 ASW RD PTFE/ACM 65x79x20</p> <p>K:→ 257.770 11 11 7 511 396 ASW LD PTFE/ACM 90x110x12</p>	
<p>VAS 425.290 FPM 403.730 11 34 2 245 151 FPM 8x</p>	<p>833.274 11 62 2 243 782 2x </p> <p>914.012 11 62 2 245 274 </p>	<p>424.870 11 61 2 245 438 4x </p>	<p>a) 445.240 11 13 9 067 655 </p> <p>b) 455.740 11 13 7 535 106 +07 11 9 963 151 M 12x1,5x16</p> <p>b) 110.906 07 11 9 963 151 CU A 12x17x1,5</p>	<p>K:← 050.260 11 14 2 249 532 AS RD PTFE/ACM 48x65x10</p> <p>K:← 586.676 11 14 1 275 466 A/BS RD FPM 48x65x10</p> <p>K:→ 301.870 11 14 2 249 533 A/BS LD PTFE/FPM 90x110x12</p> <p>K:→ 702.994 11 14 1 706 999 A/BS LD FPM 90x110x12</p>	<p>TLS 703.871 </p>

BMW

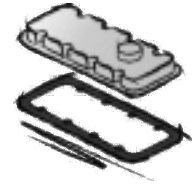
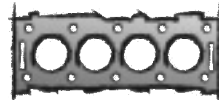
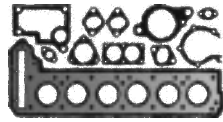

M10 B18 (184EA)/(184EB)

4 Cyl. 1766 ccm
Cyl. 89,0 Ø

- 318 i (E30)**
09/1982 → 06/1990
- 320 i (E21)**
09/1979 → 12/1983
- 518 i (E12)**
06/1979 → 06/1981
- 518 i (E28)**
05/1981 → 12/1987

ES⊕ **834.009**
11 12 9 065 554
CS* **835.080**
11 11 1 734 114
E21
CS* **888.435**
11 11 1 727 985
E30

774.847
11 12 1 734 279
1,50 mm $\frac{1}{16}$ 90 Ø
774.855
11 12 1 734 280
1,80 mm $\frac{1}{8}$ 90 Ø

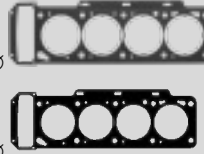

ZKS **802.720**
11 12 0 621 144 (10x)
M 12x1,75x157



774.928
11 12 1 734 276



M10 B18 (184EW)/(184EY)/ (184EZ)/(184KA)/(184VU)

4 Cyl. 1766 ccm
Cyl. 89,0 Ø

- 316 i (E30)**
08/1987 → 08/1988
- 318 i (E30)**
09/1982 → 06/1990

ES⊕ **834.009**
11 12 9 065 554
CS* **888.435**
11 11 1 727 985

774.847
11 12 1 734 279
1,50 mm $\frac{1}{16}$ 90 Ø
774.855
11 12 1 734 280
1,80 mm $\frac{1}{8}$ 90 Ø

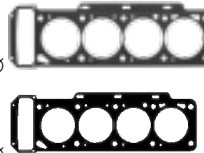





















ZKS **802.720**
11 12 0 621 144 (10x)
M 12x1,75x157



774.928
11 12 1 734 276



			<p>a) </p> <p>b) </p>	<p>K: </p> <p>N: </p>	
<p>VAS 702.706 11 34 9 059 169 FPM 08/1978→</p> <p>187.666 11 34 1 256 556 FPM →07/1978 8x</p> <p>553.190 11 34 1 273 501 FPM 08/1978→ 8x</p>	<p>835.102 11 62 1 723 876</p>  <p>888.508 ● 11 75 1 723 842 4x</p> 	<p>774.332 11 61 1 727 994 3x</p>  <p>774.341 11 61 1 727 995 1x</p> 	<p>a) 835.099 11 13 1 727 974</p>  <p>a) 329.606 11 13 1 727 983 E30</p>  <p>b) 774.390 11 13 1 273 093 M 12x1,5x18</p> <p>b) 238.708 07 11 9 963 130 AL A 12x15,5x1,5</p>	<p>K:← 587.044 11 14 1 709 632 ASW RD ACM 35x55x12</p> <p>K:→ 128.210 11 14 1 255 015 A LD VMQ 80x100x13</p> <p>K:→ 301.870 11 14 2 249 533 A/BS LD PTFE/FPM 90x110x12</p> <p>K:→ 702.994 11 14 1 706 999 A/BS LD FPM 90x110x12</p>	
<p>VAS 702.706 11 34 9 059 169 FPM</p> <p>553.190 11 34 1 273 501 FPM 8x</p>	<p>835.102 11 62 1 723 876</p>  <p>888.508 ● 11 75 1 723 842 4x</p> 	<p>774.332 11 61 1 727 994 3x</p>  <p>774.341 11 61 1 727 995 1x</p> 	<p>a) 835.099 11 13 1 727 974</p>  <p>a) 329.606 11 13 1 727 983</p>  <p>b) 774.390 11 13 1 273 093 M 12x1,5x18</p> <p>b) 238.708 07 11 9 963 130 AL A 12x15,5x1,5</p>	<p>K:← 587.044 11 14 1 709 632 ASW RD ACM 35x55x12</p> <p>K:→ 128.210 11 14 1 255 015 A LD VMQ 80x100x13</p> <p>K:→ 301.870 11 14 2 249 533 A/BS LD PTFE/FPM 90x110x12</p> <p>K:→ 702.994 11 14 1 706 999 A/BS LD FPM 90x110x12</p>	

BMW



M10 B18 (184VA)

4 Cyl. **1766 ccm**
Cyl. 89,0 Ø

318 (E21)

08/1975 → 08/1980

318 i (E21)

11/1979 → 08/1982

ES⊕ **834.009**
11 12 9 065 554
318 i E21
CS* **835.080**
11 11 1 734 114

774.847
11 12 1 734 279
1,50 mm $\frac{\pm}{\text{mm}}$ 90 Ø



774.855
11 12 1 734 280
1,80 mm $\frac{\pm}{\text{mm}}$ 90 Ø



ZKS **802.720**
11 12 0 621 144 (10x)
M 12x1,75x157



774.928
11 12 1 734 276



M40 B18 (184E1)

4 Cyl. **1796 ccm**
Cyl. 84,0 Ø

318 i (E30)

06/1987 → 06/1994

318 i (E36)

09/1990 → 06/1994

518 i (E34)

09/1989 → 04/1994

ES⊕ **444.310**
incl. 888.986
11 12 0 007 611

ES⊕ **748.995**
11 12 9 059 241

CS* **817.430**
11 11 9 059 257
E30/E34

CS* **893.749**
11 11 1 734 268
E36

888.979
11 12 7 504 586
1,74 mm $\frac{\pm}{\text{mm}}$ 85 Ø

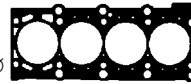

888.986
11 12 7 504 587
2,04 mm $\frac{\pm}{\text{mm}}$ 85 Ø

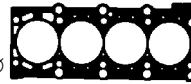



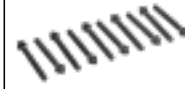

















ZKS **802.760**
11 12 1 721 939
M 10x1,5x95











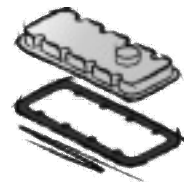
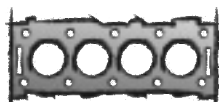
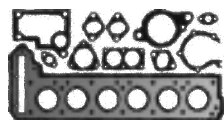







703.532
11 12 1 727 726





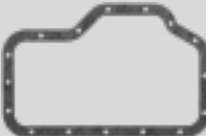



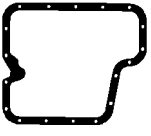

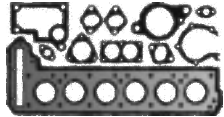
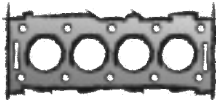

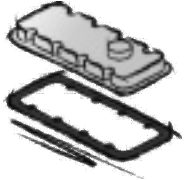





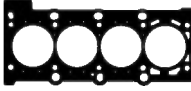







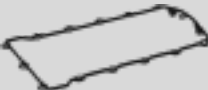









			<p>a) </p> <p>b) </p>	<p>K: </p> <p>N: </p>	
<p>VAS 702.706 11 34 9 059 169 FPM 08/1978→</p> <p>187.666 11 34 1 256 556 FPM →07/1978 8x</p> <p>553.190 11 34 1 273 501 FPM 08/1978→ 8x</p>	<p>835.102 11 62 1 723 876 318 i E21</p>  <p>888.508 ● 11 75 1 723 842 318 i E21 4x</p>  <p>888.516 11 62 1 723 877 318 E21 4x</p> 	<p>774.332 11 61 1 727 994 318 i E21 3x</p>  <p>774.341 11 61 1 727 995 318 i E21 1x</p>  <p>827.585 11 61 1 734 436 318 E21 3x</p>  <p>827.592 11 61 1 734 435 318 E21 1x</p> 	<p>a) 835.099 11 13 1 727 974</p>  <p>b) 774.390 11 13 1 273 093 M 12x1,5x18</p> <p>b) 238.708 07 11 9 963 130 AL A 12x15,5x1,5</p>	<p>K:← 587.044 11 14 1 709 632 ASW RD ACM 35x55x12</p> <p>K:→ 128.210 11 14 1 255 015 A LD VMQ 80x100x13</p> <p>K:→ 301.870 11 14 2 249 533 A/BS LD PTFE/FPM 90x110x12</p> <p>K:→ 702.994 11 14 1 706 999 A/BS LD FPM 90x110x12</p>	
<p>VAS 825.042 11 34 9 059 171 FPM</p> <p>701.289 11 34 1 706 707 FPM 8x</p>	<p>267.840 11 62 1 743 719</p>	<p>670.780 11 61 1 734 683</p> 	<p>a) 762.033 11 13 1 739 592 ↑</p>  <p>a) 693.057 11 13 1 709 815 E30/E36</p>  <p>a) 762.084 11 13 1 727 563 E34</p>  <p>b) 774.390 11 13 1 273 093 M 12x1,5x18</p> <p>b) 238.708 07 11 9 963 130 AL A 12x15,5x1,5</p>	<p>K:← 748.889 11 14 1 714 617 A/BS RD FPM 42x52x7,5</p> <p>K:→ 301.870 11 14 2 249 533 A/BS LD PTFE/FPM 90x110x12</p> <p>K:→ 702.994 11 14 1 706 999 A/BS LD FPM 90x110x12</p> <p>N:← 586.668 11 12 1 285 609 ASW WD FPM 38x50x7</p>	

BMW



			<p>a) </p> <p>b) </p>	<p>K: </p> <p>N: </p>	
<p>VAS 825.042 11 34 9 059 171 FPM →09/1992 2x</p> <p>VAS 424.800 FPM 09/1992→</p> <p>701.289 11 34 1 706 707 FPM →09/1992 16x</p> <p>403.730 11 34 2 245 151 FPM 09/1992→ 16x</p>	<p>821.020 11 62 1 728 983 2x</p> 	<p>835.692 11 61 1 734 684</p> 	<p>a) 762.033 11 13 1 739 592 ↑</p>  <p>a) 693.057 11 13 1 709 815 →09/1992</p>  <p>b) 774.390 11 13 1 273 093 M 12x1,5x18</p> <p>b) 238.708 07 11 9 963 130 AL A 12x15,5x1,5</p>	<p>K:← 761.796 11 14 1 721 560 AW/BS RD FPM 44x60x10</p> <p>K:→ 301.870 11 14 2 249 533 A/BS LD PTFE/FPM 90x110x12</p> <p>K:→ 702.994 11 14 1 706 999 A/BS LD FPM 90x110x12</p>	
<p>VAS 825.042 11 34 9 059 171 FPM</p> <p>701.289 11 34 1 706 707 FPM 8x</p>	<p>267.840 11 62 1 743 719</p>	<p>670.780 11 61 1 734 683</p> 	<p>a) 762.033 11 13 1 739 592 →09/1995</p>  <p>a) 215.190 11 13 1 739 813 09/1995→</p>  <p>a) 762.084 11 13 1 727 563 E34</p>  <p>b) 774.390 11 13 1 273 093 M 12x1,5x18</p> <p>b) 238.708 07 11 9 963 130 AL A 12x15,5x1,5</p>	<p>K:← 214.680 11 14 1 439 570 AW/BS RD PTFE/ACM 44x60x10</p> <p>K:← 761.796 11 14 1 721 560 AW/BS RD FPM 44x60x10</p> <p>K:→ 301.870 11 14 2 249 533 A/BS LD PTFE/FPM 90x110x12</p> <p>K:→ 702.994 11 14 1 706 999 A/BS LD FPM 90x110x12</p>	

BMW 				
N42 B18 A N46 B18 A 4 Cyl. 1796 ccm Cyl. 84,0 Ø 316 i (E46) 02/2002 → 02/2005 316 ti (E46) 06/2001 → 02/2005	ES⊕ 458.390 11 12 7 511 535  CS* 458.400 11 11 7 511 529	746.902 11 12 7 509 710 0,40 mm $\frac{\pm}{\pm}$ 84,5 Ø 024.352 11 12 7 509 711 0,70 mm $\frac{\pm}{\pm}$ 84,5 Ø  	ZKS 010.230 11 12 7 511 534 M 10x1,5x170 M 8x1,25x95/125 	ZKHS 382.711 
M43 B19 (194E1) 4 Cyl. 1895 ccm Cyl. 85,0 Ø 316 i (E36) 01/1999 → 08/2000 316 i (E46) 12/1998 → 02/2002 318 Ci (E46) 12/1999 → 08/2001 318 i (E46) 12/1997 → 09/2001 Z3 (E36) 07/1998 → 01/2003	ES⊕ 363.190 11 12 1 712 309 CS* 374.710 11 11 1 712 981	267.830 11 12 1 708 585 1,74 mm $\frac{\pm}{\pm}$ 86 Ø 	ZKS 802.760 11 12 1 721 939 M 10x1,5x95 	ZKHS 040.060 11 12 1 432 885 +11 12 1 721 879 (10x)  422.370 11 12 1 432 885  767.891 11 12 1 721 879 10x 
M44 B19 (194S1) 4 Cyl. 1895 ccm Cyl. 85,0 Ø 318 i (E36) 09/1995 → 09/1999 318 is (E36) 01/1996 → 05/1998 318 ti (E36) 01/1996 → 08/1999 Z3 (E36) 11/1995 → 03/1999	ES⊕ 495.840 11 12 9 070 615 CS* 495.850 11 11 1 743 981	495.790 11 12 1 739 849 1,74 mm $\frac{\pm}{\pm}$ 86 Ø 	ZKS 802.760 11 12 1 721 939 M 10x1,5x95 	ZKHS 135.391  767.867 11 12 1 721 876  767.891 11 12 1 721 879 15x 

			<p>a) </p> <p>b) </p>	<p>K: </p> <p>N: </p>	
<p>VAS 199.440 11 34 0 029 751 FPM</p> <p>198.770 11 34 7 505 417 FPM 16x</p>	<p>438.710 18 40 7 506 778</p> 	<p>AAS 445.130 11 61 7 530 703</p> 	<p>a) 190.640 11 13 7 511 224</p>  <p>b) 877.940 11 13 7 568 309 +07 11 9 963 150 M 12x1,5x10</p> <p>b) 068.616 07 11 9 963 150 AL A 12x17x1,5</p> <p>b) 110.906 07 11 9 963 151 CU A 12x17x1,5</p>	<p>K:← 257.400 11 11 7 511 395 ASW RD PTFE/ACM 65x79x20</p> <p>K:→ 257.770 11 11 7 511 396 ASW LD PTFE/ACM 90x110x12</p>	
<p>VAS 825.042 11 34 9 059 171 FPM</p> <p>701.289 11 34 1 706 707 FPM 8x</p>	<p>267.840 11 62 1 743 719</p>	<p>359.370 11 61 1 437 384 4x</p> 	<p>a) 373.160 11 13 1 432 109</p>  <p>b) 774.390 11 13 1 273 093 M 12x1,5x18</p> <p>b) 238.708 07 11 9 963 130 AL A 12x15,5x1,5</p>	<p>K:← 214.680 11 14 1 439 570 AW/BS RD PTFE/ACM 44x60x10</p> <p>K:← 761.796 11 14 1 721 560 AW/BS RD FPM 44x60x10</p> <p>K:→ 301.870 11 14 2 249 533 A/BS LD PTFE/FPM 90x110x12</p> <p>K:→ 702.994 11 14 1 706 999 A/BS LD FPM 90x110x12</p>	
<p>VAS 424.800 FPM</p> <p>403.730 11 34 2 245 151 FPM 16x</p>	<p>821.020 11 62 1 728 983 2x</p> 	<p>835.692 11 61 1 734 684</p> 	<p>a) 215.190 11 13 1 739 813</p>  <p>b) 774.390 11 13 1 273 093 M 12x1,5x18</p> <p>b) 238.708 07 11 9 963 130 AL A 12x15,5x1,5</p>	<p>K:← 761.796 11 14 1 721 560 AW/BS RD FPM 44x60x10</p> <p>K:→ 301.870 11 14 2 249 533 A/BS LD PTFE/FPM 90x110x12</p> <p>K:→ 702.994 11 14 1 706 999 A/BS LD FPM 90x110x12</p>	

BMW

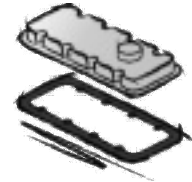
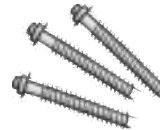
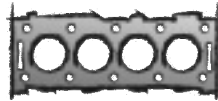
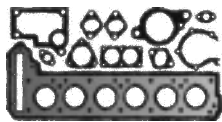

M47 D20 (204D1)

4 Cyl. **1951 ccm**
Cyl. 84,0 Ø

- 318 d (E46)**
09/2001 → 03/2003
- 320 d (E46)**
02/1998 → 09/2001
- 520 d (E39)**
02/2000 → 09/2003

ES⊕ **293.250**
11 12 2 247 501

075.920 ●
11 12 2 247 498
 0,770 mm
→
0,920 mm
1,45 mm $\frac{1}{4}$ 84,5 Ø
1 ⊗

075.950
11 12 2 247 499
 0,930 mm
→
1,030 mm
1,55 mm $\frac{1}{4}$ 84,5 Ø
2 ⊗

075.960
11 12 2 247 500
 1,040 mm
→
1,180 mm
1,65 mm $\frac{1}{4}$ 84,5 Ø
3 ⊗

ZKS **802.661**
11 12 9 067 792
M 12x1,5x147

ZKHS **166.260**

302.180
11 12 2 246 996

M20 B20
M20 B20 (206EA)/(206EB)/
(206EC)/(206EE)/(206EY)/
(206EZ)/(206KA)/(206VA)

6 Cyl. **1990 ccm**
Cyl. 80,0 Ø

- 320/6 (E21)**
08/1977 → 10/1982
- 320 i (E30)**
09/1982 → 11/1993
- 520/6 (E12)**
03/1977 → 06/1981
- 520 i/6 (E12)**
09/1976 → 07/1978
- 520 i (E28)**
06/1981 → 12/1987
- 520 i (E34)**
06/1987 → 09/1990

















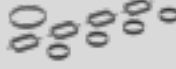

ES⊕ **820.911**
11 12 9 059 248
→08/1982
ES⊕ **147.360**
incl. 829.994
11 12 1 730 876
09/1982→
ES⊕ **817.384**
11 12 1 730 876
09/1982→
CS* **892.106**
11 11 9 063 134

829.986
11 12 1 738 609
1,88 mm $\frac{1}{4}$ 81 Ø

829.994
11 12 1 738 611
2,08 mm $\frac{1}{4}$ 81 Ø

ZKS **820.229**
11 12 1 726 478
M 10x1,5x150

774.693
11 12 1 730 271

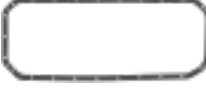
			<p>a) </p> <p>b) </p>	<p>K: </p> <p>N: </p>	
<p>VAS 214.800 11 34 9 070 982 157.560 11 34 2 247 171 FPM 16x</p>	<p>066.391 11 62 7 796 480 2x </p>	<p>AAS 228.680 11 61 7 790 198 (4x) +11 61 2 245 439 (1x) +11 61 1 246 945 (4x)  074.990 11 61 7 790 198 4x </p>	<p>a) 326.100 11 13 8 070 005  b) 455.740 11 13 7 535 106 +07 11 9 963 151 M 12x1,5x16 b) 110.906 07 11 9 963 151 CU A 12x17x1,5</p>	<p>K:← 050.260 11 14 2 249 532 AS RD PTFE/ACM 48x65x10 K:→ 301.870 11 14 2 249 533 A/BS LD PTFE/FPM 90x110x12</p>	<p>TLS 703.871 </p>
<p>VAS 825.050 11 34 9 059 172 FPM 701.289 11 34 1 706 707 FPM 12x</p>	<p>888.516 11 62 1 723 877 →08/1982 6x  495.900 11 62 1 728 489 09/1982→ 2x </p>	<p>776.602 11 61 1 730 787 →08/1982 4x  810.851 11 61 1 730 743 →08/1982  774.553 11 61 1 726 010 09/1982→ 4x  774.561 11 61 1 726 012 09/1982→ </p>	<p>a) 888.346 11 13 1 730 234  b) 774.390 11 13 1 273 093 M 12x1,5x18 b) 238.708 07 11 9 963 130 AL A 12x15,5x1,5</p>	<p>K:← 586.676 11 14 1 275 466 A/BS RD FPM 48x65x10 K:→ 301.870 11 14 2 249 533 A/BS LD PTFE/FPM 90x110x12 K:→ 702.994 11 14 1 706 999 A/BS LD FPM 90x110x12 N:← 586.668 11 12 1 285 609 ASW WD FPM 38x50x7</p>	

BMW



M50 B20 (206S1)

6 Cyl. 1990 ccm
Cyl. 80,0 Ø

320 i (E36)

01/1991 → 11/1998

520 i (E34)

04/1990 → 07/1996

ES⊕ **893.838**
11 12 1 730 252
CS* **816.982**
11 11 1 730 251

752.215
11 12 1 726 623
1,74 mm $\frac{1}{16}$ 81 Ø



833.258
11 12 1 726 627
2,04 mm $\frac{1}{8}$ 81 Ø

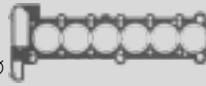

ZKS **802.740**
11 12 1 721 938
M 10x1,5x95



ZKHS **302.320**
11 12 9 070 530

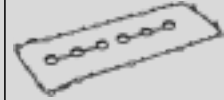

891.312
11 12 1 748 049

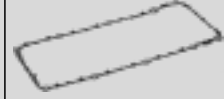

827.312
11 12 1 735 721
2x



436.010
11 12 1 437 395
15x



M50 B20 (206S2)

6 Cyl. 1990 ccm
Cyl. 80,0 Ø

320 i (E36)

01/1991 → 11/1999

520 i (E34)

04/1990 → 07/1996

ES⊕ **445.520**
11 12 9 064 466
CS* **424.770**
11 11 9 064 460

752.215
11 12 1 726 623
1,74 mm $\frac{1}{16}$ 81 Ø



833.258
11 12 1 726 627
2,04 mm $\frac{1}{8}$ 81 Ø



ZKS **802.740**
11 12 1 721 938
M 10x1,5x95



ZKHS **302.340**
11 12 0 034 107



ZKHS **318.550**
11 12 0 034 107
+11 12 1 437 395 (15x)



147.610
11 12 1 738 701













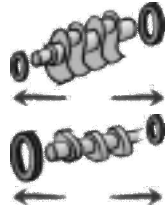

827.312
11 12 1 735 721
2x

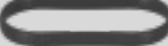
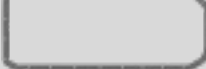

436.010
11 12 1 437 395
15x



			<p>a) </p> <p>b) </p>	<p>K: </p> <p>N: </p>	
<p>VAS 825.050 11 34 9 059 172 FPM 2x</p> <p>701.289 11 34 1 706 707 FPM 24x</p>	<p>821.020 11 62 1 728 983 3x</p> 	<p>888.605 11 61 1 717 259 6x</p> 	<p>a) 811.653 11 13 1 720 519</p>  <p>b) 774.390 11 13 1 273 093 M 12x1,5x18</p> <p>238.708 07 11 9 963 130 AL A 12x15,5x1,5</p>	<p>K:← 586.676 11 14 1 275 466 A/BS RD FPM 48x65x10</p> <p>K:→ 301.870 11 14 2 249 533 A/BS LD PTFE/FPM 90x110x12</p> <p>K:→ 702.994 11 14 1 706 999 A/BS LD FPM 90x110x12</p>	
<p>VAS 424.820 FPM</p> <p>403.730 11 34 2 245 151 FPM 24x</p>	<p>821.020 11 62 1 728 983 3x</p> 	<p>888.524 11 61 1 720 740 6x</p> 	<p>a) 424.510 11 13 9 065 875</p>  <p>b) 774.390 11 13 1 273 093 M 12x1,5x18</p> <p>b) 238.708 07 11 9 963 130 AL A 12x15,5x1,5</p>	<p>K:← 586.676 11 14 1 275 466 A/BS RD FPM 48x65x10</p> <p>K:→ 301.870 11 14 2 249 533 A/BS LD PTFE/FPM 90x110x12</p> <p>K:→ 702.994 11 14 1 706 999 A/BS LD FPM 90x110x12</p>	

BMW

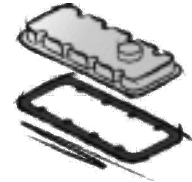
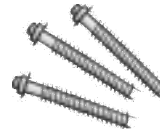
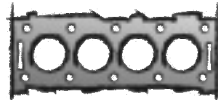
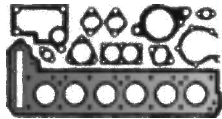

M52 B20 (206S3)/(206S4)

6 Cyl. 1990 ccm
Cyl. 80,0 Ø

320 Ci (E46)

02/1999 → 08/2001

320 i (E36)

01/1991 → 11/1999

320 i (E46)

03/1998 → 09/2000

520 i (E39)

01/1996 → 06/2003

Z3 (E36)

04/1999 → 01/2003

ES⊕ **445.450**

11 12 1 740 982

→09/1995

ES⊕ **445.460**

11 12 1 427 825

10/1995→

→09/1998

ES⊕ **366.560**

11 12 1 436 822

+11 62 1 732 969 (2x)

09/1998→



CS* **424.901**

11 11 1 740 981

→09/1998

CS* **359.160**

11 11 1 432 478

09/1998→

752.215

11 12 1 726 623

1,74 mm $\frac{3}{8}$ 81 Ø

→09/1998

833.258

11 12 1 726 627

2,04 mm $\frac{3}{8}$ 81 Ø

→09/1998

154.980

11 12 7 506 983

0,70 mm $\frac{3}{8}$ 81 Ø

09/1998→

373.180

11 12 7 506 984

1,00 mm $\frac{3}{8}$ 81 Ø

09/1998→

ZKS **802.820**

11 12 1 740 065

M 10x1,5x110



ZKHS **302.340**

11 12 0 034 107

→09/1995



ZKHS **318.550**

11 12 0 034 107

+11 12 1 437 395 (15x)

→09/1995



ZKHS **302.350**

11 12 0 034 108

09/1995→

→09/1998



ZKHS **318.580**

11 12 0 034 108

+11 12 1 437 395 (15x)

09/1995→

→09/1998

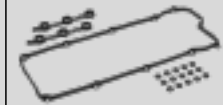

ZKHS **318.590**

11 12 9 070 990

+11 12 1 437 395 (15x)

09/1998→



ZKHS **326.560**

11 12 9 070 990

09/1998→



147.610

11 12 1 738 701

→09/1995

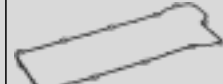

425.370

11 12 1 703 342

10/1995→

→09/1998















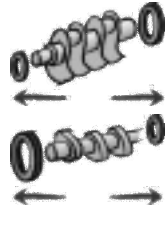



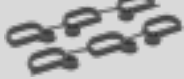

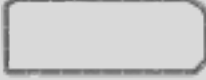



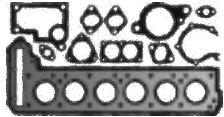
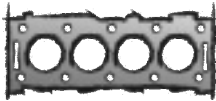

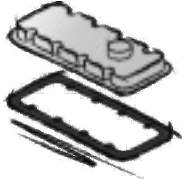





827.312

















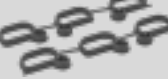

11 12 1 735 721

→09/1995

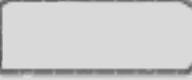
2x

			<p>a) </p> <p>b) </p>	<p>K: </p> <p>N: </p>	
<p>VAS 424.820 FPM 403.730 11 34 2 245 151 FPM 24x</p>	<p>147.581 11 62 1 744 252 →09/1998 2x </p> <p>326.250 11 62 1 732 969 09/1998→ Euro 2 / Euro 3 (D3) 2x </p>	<p>AAS 366.500 11 61 1 436 631 09/1998→ </p> <p>147.590 11 61 1 740 069 2x →09/1998 </p>	<p>a) 424.510 11 13 9 065 875 </p> <p>b) 774.390 11 13 1 273 093 M 12x1,5x18</p> <p>b) 110.906 07 11 9 963 151 CU A 12x17x1,5</p> <p>b) 238.708 07 11 9 963 130 AL A 12x15,5x1,5</p>	<p>K:← 050.260 11 14 2 249 532 AS RD PTFE/ACM 48x65x10</p> <p>K:← 586.676 11 14 1 275 466 A/BS RD FPM 48x65x10</p> <p>K:→ 301.870 11 14 2 249 533 A/BS LD PTFE/FPM 90x110x12</p> <p>K:→ 702.994 11 14 1 706 999 A/BS LD FPM 90x110x12</p>	

BMW 				
M52 B20 (206S3)/(206S4) 6 Cyl. 1990 ccm Cyl. 80,0 Ø 320 Ci (E46) 02/1999 → 08/2001 320 i (E36) 01/1991 → 11/1999 320 i (E46) 03/1998 → 09/2000 520 i (E39) 01/1996 → 06/2003 Z3 (E36) 04/1999 → 01/2003	ES⊕ 445.450 11 12 1 740 982 →09/1995 ES⊕ 445.460 11 12 1 427 825 10/1995→ →09/1998 ES⊕ 366.560 11 12 1 436 822 +11 62 1 732 969 (2x) 09/1998→  CS* 424.901 11 11 1 740 981 →09/1998 CS* 359.160 11 11 1 432 478 09/1998→	752.215 11 12 1 726 623 1,74 mm $\frac{3}{16}$ 81 Ø  →09/1998 833.258 11 12 1 726 627 2,04 mm $\frac{3}{16}$ 81 Ø  →09/1998 154.980 11 12 7 506 983 0,70 mm $\frac{3}{16}$ 81 Ø  09/1998→ 373.180 11 12 7 506 984 1,00 mm $\frac{3}{16}$ 81 Ø  09/1998→	ZKS 802.820 11 12 1 740 065 M 10x1,5x110 	 425.390 11 12 1 748 872 10/1995→ 2x  436.010 11 12 1 437 395 15x 
S14 204 EA S14 B20 (204EA) 4 Cyl. 1990 ccm Cyl. 89,0 Ø 320 is (E30) 05/1988 → 12/1990	ES⊕ 893.773 11 12 1 316 992 CS* 893.781 11 11 1 316 993	893.765 11 12 1 316 714 1,82 mm $\frac{3}{16}$ 94 Ø 		762.041 11 12 1 312 171  755.991 11 12 1 304 329 2x 
B47 C20 A 4 Cyl. 1995 ccm Cyl. 84,0 Ø 218 d (F45/46) 11/2013 → 220 d (F45/46) 03/2014 → X1 18 d (F48) 11/2014 → X1 20 d (F48) 07/2015 → X2 18 d (F39) 03/2018 → X2 20 d (F39) 11/2017 →	ES 648.160  CS* 648.340 OKS 582.190 11 42 8 591 461 	172.891 11 12 8 513 699 1,45 mm $\frac{3}{16}$ 85 Ø 1 ⊗ 173.011 11 12 8 513 700 1,55 mm $\frac{3}{16}$ 85 Ø 2 ⊗ 173.021 11 12 8 513 701 1,65 mm $\frac{3}{16}$ 85 Ø 3 ⊗	ZKS 233.370 11 12 8 511 621 (10x) M 12x1,5x200 	ZKHS 597.000 11 12 8 583 293

			<p>a) </p> <p>b) </p>	<p>K: </p> <p>N: </p>	
<p>VAS 424.820 FPM 403.730 11 34 2 245 151 FPM 24x</p>	<p>147.581 11 62 1 744 252 →09/1998 2x </p> <p>326.250 11 62 1 732 969 09/1998→ Euro 2 / Euro 3 (D3) 2x </p>	<p>AAS 366.500 11 61 1 436 631 09/1998→ </p> <p>147.590 11 61 1 740 069 2x →09/1998 </p>	<p>a) 424.510 11 13 9 065 875 </p> <p>b) 774.390 11 13 1 273 093 M 12x1,5x18</p> <p>b) 110.906 07 11 9 963 151 CU A 12x17x1,5</p> <p>b) 238.708 07 11 9 963 130 AL A 12x15,5x1,5</p>	<p>K:← 050.260 11 14 2 249 532 AS RD PTFE/ACM 48x65x10</p> <p>K:← 586.676 11 14 1 275 466 A/BS RD FPM 48x65x10</p> <p>K:→ 301.870 11 14 2 249 533 A/BS LD PTFE/FPM 90x110x12</p> <p>K:→ 702.994 11 14 1 706 999 A/BS LD FPM 90x110x12</p>	
<p>VAS 825.042 11 34 9 059 171 FPM 701.289 11 34 1 706 707 FPM 16x</p>	<p>762.016 11 62 1 312 992 4x </p>		<p>a) 835.099 11 13 1 727 974 ↑ </p> <p>a) 329.606 11 13 1 727 983 </p> <p>b) 774.390 11 13 1 273 093 M 12x1,5x18</p> <p>b) 238.708 07 11 9 963 130 AL A 12x15,5x1,5</p>	<p>K:← 761.796 11 14 1 721 560 AW/BS RD FPM 44x60x10</p> <p>K:→ 301.870 11 14 2 249 533 A/BS LD PTFE/FPM 90x110x12</p> <p>K:→ 702.994 11 14 1 706 999 A/BS LD FPM 90x110x12</p>	
<p>VAS 530.070 11 34 7 807 347 539.420 FPM 16x</p>	<p>503.721 11 62 7 811 221 2x </p>	<p>593.390 11 61 8 571 001 4x </p>	<p>a) 030.793 Dirko HT</p> <p>b) 455.740 11 13 7 535 106 +07 11 9 963 151 M 12x1,5x16</p> <p>b) 110.507 07 11 9 963 132 CU A 12x16x1</p>	<p>K:← 584.160 11 11 7 802 665 AW/BS OF RD FPM 55x68x8</p> <p>K:→ 492.060 11 14 7 797 490 AW/BS OF LD FPM 90x104x9</p>	

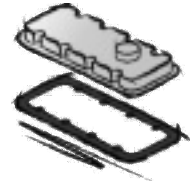
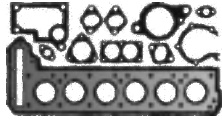
BMW**B47 C20 B**

4 Cyl. **1995 ccm**
Cyl. 84,0 Ø

- 118 d (F40)**
07/2019 →
- 120 d (F40)**
07/2019 →
- 218 d (F44)**
11/2019 →
- 218 d (F45/46)**
11/2013 →
- 218d (U06)**
11/2021 →
- 220 d (F44)**
11/2019 →
- 220 d (F45/46)**
03/2014 →
- X1 18 d (F48)**
11/2014 →
- X1 20 d (F48)**
07/2015 →
- X1 25 d (F48)**
11/2014 →
- X2 18 d (F39)**
03/2018 →
- X2 20 d (F39)**
11/2017 →
- X2 25 d (F39)**
11/2017 →

ES⊕ **648.450**CS* **648.340**OKS **582.190**

11 42 8 591 461

**172.891**

11 12 8 513 699
1,45 mm $\frac{+}{-}$ 85 Ø
1 ⊗

173.011

11 12 8 513 700
1,55 mm $\frac{+}{-}$ 85 Ø
2 ⊗

173.021











11 12 8 513 701
1,65 mm $\frac{+}{-}$ 85 Ø
3 ⊗

ZKS 233.370

11 12 8 511 621 (10x)
M 12x1,5x200

**ZKHS 597.000**

11 12 8 583 293

			<p>a) </p> <p>b) </p>	<p>K: </p> <p>N: </p>	
<p>VAS 530.070 11 34 7 807 347 539.420 FPM 16x</p>	<p>503.721 11 62 7 811 221 2x</p> 	<p>593.390 11 61 8 571 001 4x</p> 	<p>a) 030.793 Dirko HT</p> <p>b) 455.740 11 13 7 535 106 +07 11 9 963 151 M 12x1,5x16</p> <p>b) 110.507 07 11 9 963 132 CU A 12x16x1</p>	<p>K:← 584.160 11 11 7 802 665 AW/BS OF RD FPM 55x68x8</p> <p>K:→ 492.060 11 14 7 797 490 AW/BS OF LD FPM 90x104x9</p>	

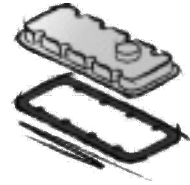
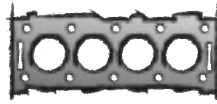
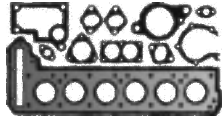
BMW**B47 D20 A**

4 Cyl. 1995 ccm
Cyl. 84,0 Ø

- 118 d (F20/21)**
07/2011 →
- 120 d (F20/21)**
07/2011 →
- 218 d (F22/23)**
03/2014 →
- 220 d (F22/23)**
03/2014 →
- 316 d (F30/31/35)**
03/2012 → 06/2019
- 318 d (F30/31/34/35)**
03/2012 →
- 320 d (F30/31/34/35)**
11/2011 →
- 418 d (F32/36/82)**
03/2014 → 12/2020
- 420 d (F32/33/36/82/83)**
07/2013 →
- 518 d (F10/11/18)**
07/2013 → 02/2017
- 520 d (F07/10/11/18)**
06/2010 → 02/2017
- 520 d (F10/11/18)**
06/2010 → 10/2016
- 520 d (G30/31)**
09/2016 → 10/2019
- 523 d (G30/31)**
09/2016 → 10/2019
- X3 18 d (F25)**
04/2014 → 08/2017
- X3 18 d (G01)**
04/2018 →
- X3 20 d (F25)**
04/2014 → 08/2017
- X3 20 d (G01)**
08/2017 →
- X4 20 d (F26)**
04/2014 → 03/2018
- X4 20 d (G02)**
04/2018 → 03/2020

ES **648.160**CS* **648.330**OKS **634.970**

11 42 8 591 462

**172.891**

11 12 8 513 699
1,45 mm $\frac{+}{-}$ 85 Ø
1 ⊗

173.011

11 12 8 513 700
1,55 mm $\frac{+}{-}$ 85 Ø
2 ⊗

173.021











11 12 8 513 701
1,65 mm $\frac{+}{-}$ 85 Ø
3 ⊗

ZKS 233.370

11 12 8 511 621 (10x)
M 12x1,5x200

**ZKHS 597.000**

11 12 8 583 293

			<p>a) </p> <p>b) </p>	<p>K: </p> <p>N: </p>	
<p>VAS 530.070 11 34 7 807 347 539.420 FPM 16x</p>	<p>503.721 11 62 7 811 221 2x</p> 	<p>593.390 11 61 8 571 001 4x</p> 	<p>a) 030.793 Dirko HT</p> <p>b) 455.740 11 13 7 535 106 +07 11 9 963 151 M 12x1,5x16</p> <p>b) 110.507 07 11 9 963 132 CU A 12x16x1</p>	<p>K:← 584.160 11 11 7 802 665 AW/BS OF RD FPM 55x68x8</p> <p>K:→ 492.060 11 14 7 797 490 AW/BS OF LD FPM 90x104x9</p>	

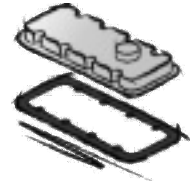
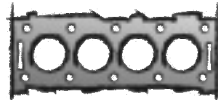
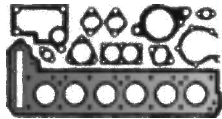
BMW**B47 D20 B**

4 Cyl. **1995 ccm**
Cyl. 84,0 Ø

125 d (F20/21)
03/2012 →

220 d (G42)
08/2021 →

225 d (F22/23)
07/2015 →

316 d (G20/21)
03/2020 →

318 d (G20/21)
03/2019 →

320 d (G20/21)
11/2018 →

325 d (F30/31/34/35)
03/2016 → 02/2018

420 d (G22/23)
07/2020 →

420 d (G26)
07/2021 →

425 d (F32/33/36/82/83)
03/2016 → 02/2018

518 d (G30/31)
07/2018 →

520 d (G30/31)
09/2016 →

523 d (G30/31)
09/2016 →

525 d (G30/31)
07/2017 → 06/2019

620 d (G32)
07/2018 →

725 d (G11/12)
07/2016 → 02/2019

X3 18 d (G01)
04/2018 →

X3 20 d (G01)
08/2017 →

X3 25 d (G01)
04/2018 →

X4 20 d (G02)
04/2018 →

X4 25 d (G02)
04/2018 →

X5 25 d (F15/85)
08/2015 → 07/2018

X5 25 d (G05)
08/2019 →

ES⊕ **648.450**



CS* **648.330**

OKS **634.970**

11 42 8 591 462



172.891

11 12 8 513 699

1,45 mm $\frac{+}{-}$ 85 Ø

1 ⊗

173.011

11 12 8 513 700

1,55 mm $\frac{+}{-}$ 85 Ø

2 ⊗

173.021

11 12 8 513 701

1,65 mm $\frac{+}{-}$ 85 Ø

3 ⊗

ZKS **233.370**











11 12 8 511 621 (10x)

M 12x1,5x200



ZKHS **597.000**

11 12 8 583 293

			<p>a) </p> <p>b) </p>	<p>K: </p> <p>N: </p>	
<p>VAS 530.070 11 34 7 807 347 539.420 FPM 16x</p>	<p>503.721 11 62 7 811 221 2x</p> 	<p>593.390 11 61 8 571 001 4x</p> 	<p>a) 030.793 Dirko HT</p> <p>b) 455.740 11 13 7 535 106 +07 11 9 963 151 M 12x1,5x16</p> <p>b) 110.507 07 11 9 963 132 CU A 12x16x1</p>	<p>K:← 584.160 11 11 7 802 665 AW/BS OF RD FPM 55x68x8</p> <p>K:→ 492.060 11 14 7 797 490 AW/BS OF LD FPM 90x104x9</p>	

BMW

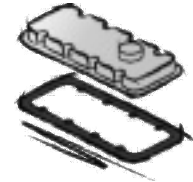
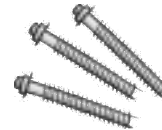
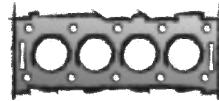
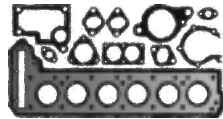

M47 D20 (204D4)

4 Cyl. 1995 ccm
Cyl. 84,0 Ø

- 118 d (E81/82/87/88)**
06/2004 → 02/2007
- 120 d (E81/82/87/88)**
06/2004 → 06/2011
- 318 d (E46)**
03/2003 → 02/2005
- 318 d (E90/91)**
03/2005 → 08/2007
- 320 Cd (E46)**
11/2003 → 12/2007
- 320 d (E46)**
09/2001 → 05/2005
- 320 d (E90/91/92/93)**
12/2004 → 06/2012
- 520 d (E60/61)**
04/2005 → 05/2010
- X3 20 d (E83)**
09/2004 → 08/2007

ES⊕ **123.740**
11 12 7 788 072

CS* **159.730**
11 11 0 394 505

268.340
11 12 7 790 052
 0,720 mm
→
0,830 mm
1,45 mm $\frac{\pm}{\pm}$
1 ▽
268.350
11 12 7 790 053
 0,840 mm
→
0,930 mm
1,55 mm $\frac{\pm}{\pm}$
2 ▽
268.360
11 12 7 790 054
 0,940 mm
→
1,040 mm
1,65 mm $\frac{\pm}{\pm}$
3 ▽

ZKS **802.661**
11 12 9 067 792
M 12x1,5x147

ZKHS **357.900**
11 12 7 794 495

123.590
11 12 7 794 495

N42 B20 N42 B20 A/B

4 Cyl. 1995 ccm
Cyl. 84,0 Ø

- 318 Ci (E46)**
12/2000 → 12/2007
- 318 i (E46)**
09/2001 → 07/2005
- 318 ti (E46)**
03/2001 → 12/2004

ES⊕ **458.390**
11 12 7 511 535

CS* **458.400**
11 11 7 511 529

746.902
11 12 7 509 710
0,40 mm $\frac{\pm}{\pm}$ 84,5 Ø

024.352
11 12 7 509 711
0,70 mm $\frac{\pm}{\pm}$ 84,5 Ø

ZKS **010.230**
11 12 7 511 534
M 10x1,5x170 M
8x1,25x95/125

ZKHS **382.711**

N43 B20 A

4 Cyl. 1995 ccm
Cyl. 84,0 Ø

- 116 i (E81/87)**
11/2008 → 12/2011
- 118 i (E81/82/87/88)**
09/2006 → 12/2013
- 120 i (E81/82/87/88)**
03/2007 → 12/2013
- 318 i (E90/91/92/93)**
05/2007 → 12/2013
- 320 i (E90/91/92/93)**
09/2006 → 12/2013
- 520 i (E60/61)**
12/2006 → 12/2010

ES⊕ **727.751**

CS* **458.400**
11 11 7 511 529

















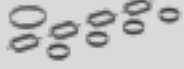

353.264
11 12 7 563 412
0,50 mm $\frac{\pm}{\pm}$ 84,8 Ø

353.292
11 12 7 578 093
0,80 mm $\frac{\pm}{\pm}$ 84,8 Ø

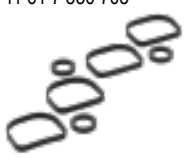
ZKS **527.450**
11 12 7 578 077
M 10x1,5x170
M9x1,25x95/125









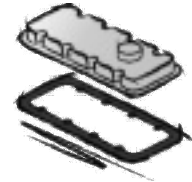
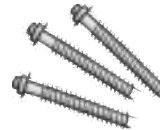
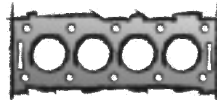
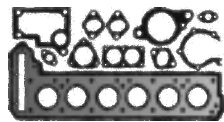







ZKHS **649.880**

724.470
11 12 7 555 738

			<p>a) </p> <p>b) </p>	<p>K: </p> <p>N: </p>	
<p>VAS 214.800 11 34 9 070 982 157.560 11 34 2 247 171 FPM 16x</p>	<p>066.391 11 62 7 796 480 2x </p>	<p>AAS 228.680 11 61 7 790 198 (4x) +11 61 2 245 439 (1x) +11 61 1 246 945 (4x)  074.990 11 61 7 790 198 4x </p>	<p>a) 071.340 11 13 0 139 259  b) 455.740 11 13 7 535 106 +07 11 9 963 151 M 12x1,5x16 b) 110.906 07 11 9 963 151 CU A 12x17x1,5</p>	<p>K:← 301.890 11 14 2 249 534 AW/BS RD PTFE/ACM 55x68x8 K:→ 073.910 11 14 7 787 262 IWD LD PTFE/FPM 90</p>	<p>TLS 703.871 </p>
<p>VAS 199.440 11 34 0 029 751 FPM 198.770 11 34 7 505 417 FPM 16x</p>	<p>438.710 18 40 7 506 778 </p>	<p>AAS 445.130 11 61 7 530 703 </p>	<p>a) 190.640 11 13 7 511 224  b) 877.940 11 13 7 568 309 +07 11 9 963 150 M 12x1,5x10 b) 068.616 07 11 9 963 150 AL A 12x17x1,5 b) 110.906 07 11 9 963 151 CU A 12x17x1,5</p>	<p>K:← 257.400 11 11 7 511 395 ASW RD PTFE/ACM 65x79x20 K:→ 257.770 11 11 7 511 396 ASW LD PTFE/ACM 90x110x12</p>	
<p>VAS 715.550 11 34 0 035 888 FPM</p>	<p>504.380 18 40 7 530 606 4x </p>	<p>AAS 727.730 11 61 7 546 983  727.720 11 61 7 546 983 4x </p>	<p>a) 190.640 11 13 7 511 224  b) 877.940 11 13 7 568 309 +07 11 9 963 150 M 12x1,5x10 b) 068.616 07 11 9 963 150 AL A 12x17x1,5 b) 110.906 07 11 9 963 151 CU A 12x17x1,5</p>	<p>K:← 257.400 11 11 7 511 395 ASW RD PTFE/ACM 65x79x20 K:→ 257.770 11 11 7 511 396 ASW LD PTFE/ACM 90x110x12</p>	

BMW







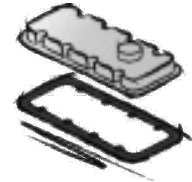
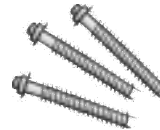
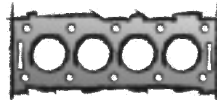
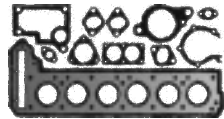













			<p>a) </p> <p>b) </p>	<p>K: </p> <p>N: </p>	
<p>VAS 199.440 11 34 0 029 751 FPM</p> <p>198.770 11 34 7 505 417 FPM 16x</p>	<p>438.710 18 40 7 506 778 E46</p>  <p>438.820 18 30 7 540 797 E87</p> 	<p>AAS 445.130 11 61 7 530 703</p> 	<p>a) 190.640 11 13 7 511 224</p>  <p>b) 877.940 11 13 7 568 309 +07 11 9 963 150 M 12x1,5x10</p> <p>b) 068.616 07 11 9 963 150 AL A 12x17x1,5</p> <p>b) 110.906 07 11 9 963 151 CU A 12x17x1,5</p>	<p>K:← 257.400 11 11 7 511 395 ASW RD PTFE/ACM 65x79x20</p> <p>K:→ 257.770 11 11 7 511 396 ASW LD PTFE/ACM 90x110x12</p>	
<p>VAS 199.440 11 34 0 029 751 FPM</p> <p>198.770 11 34 7 505 417 FPM 16x</p>	<p>438.710 18 40 7 506 778 E46, E83, E85</p>  <p>438.820 18 30 7 540 797 E60, E84 E81/82/87/88 E90/91/92/93</p> 	<p>AAS 445.130 11 61 7 530 703</p> 	<p>a) 190.640 11 13 7 511 224</p>  <p>b) 455.740 11 13 7 535 106 +07 11 9 963 151 M 12x1,5x16</p> <p>b) 877.940 11 13 7 568 309 +07 11 9 963 150 M 12x1,5x10</p> <p>b) 068.616 07 11 9 963 150 AL A 12x17x1,5</p> <p>b) 110.906 07 11 9 963 151 CU A 12x17x1,5</p>	<p>K:← 257.400 11 11 7 511 395 ASW RD PTFE/ACM 65x79x20</p> <p>K:→ 257.770 11 11 7 511 396 ASW LD PTFE/ACM 90x110x12</p>	

BMW



BMW

			<p>a) </p> <p>b) </p>	<p>K: </p> <p>N: </p>	
<p>VAS 199.440 11 34 0 029 751 FPM</p> <p>198.770 11 34 7 505 417 FPM 16x</p>	<p>438.820 18 30 7 540 797</p> 	<p>AAS 445.130 11 61 7 530 703</p> 	<p>a) 190.640 11 13 7 511 224</p>  <p>b) 877.940 11 13 7 568 309 +07 11 9 963 150 M 12x1,5x10</p> <p>b) 068.616 07 11 9 963 150 AL A 12x17x1,5</p> <p>b) 110.906 07 11 9 963 151 CU A 12x17x1,5</p>	<p>K:← 257.400 11 11 7 511 395 ASW RD PTFE/ACM 65x79x20</p> <p>K:→ 257.770 11 11 7 511 396 ASW LD PTFE/ACM 90x110x12</p>	
<p>VAS 199.440 11 34 0 029 751 FPM</p> <p>198.770 11 34 7 505 417 FPM 16x</p>	<p>438.820 18 30 7 540 797</p> 	<p>AAS 445.130 11 61 7 530 703</p> 	<p>a) 190.640 11 13 7 511 224</p>  <p>b) 877.940 11 13 7 568 309 +07 11 9 963 150 M 12x1,5x10</p> <p>b) 068.616 07 11 9 963 150 AL A 12x17x1,5</p> <p>b) 110.906 07 11 9 963 151 CU A 12x17x1,5</p>	<p>K:← 257.400 11 11 7 511 395 ASW RD PTFE/ACM 65x79x20</p> <p>K:→ 257.770 11 11 7 511 396 ASW LD PTFE/ACM 90x110x12</p>	
<p>VAS 530.070 11 34 7 807 347</p> <p>539.420 FPM 16x</p>	<p>503.721 11 62 7 811 221 2x</p> 	<p>529.960 11 61 7 801 439 4x</p> 	<p>a) 030.793 Dirko HT</p> <p>a) 492.050 11 13 7 807 302 →04/2010</p>  <p>b) 455.740 11 13 7 535 106 +07 11 9 963 151 M 12x1,5x16</p> <p>b) 110.906 07 11 9 963 151 CU A 12x17x1,5</p>	<p>K:← 584.160 11 11 7 802 665 AW/BS OF RD FPM 55x68x8</p> <p>K:→ 492.060 11 14 7 797 490 AW/BS OF LD FPM 90x104x9</p>	<p>TLS 456.100</p>  <p>TLS 736.520 E90/91/92/93 09/2010→</p> 

BMW

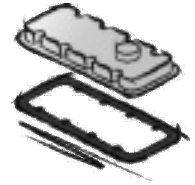
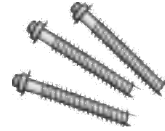
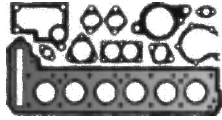

N47 D20 B

4 Cyl. **1995 ccm**
Cyl. 84,0 Ø

123 d (E81/82/87/88)
03/2007 → 12/2013

ES⊕ **530.140**
11 12 7 811 594



CS* **492.160**
11 11 7 807 292

658.190
11 12 8 506 128
→
0,920 mm



1,45 mm $\frac{\pm}{\pm}$
1 ⊗

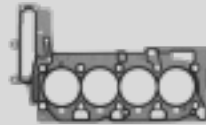

658.200
11 12 8 506 129
→
0,920 mm
→
1,030 mm



1,55 mm $\frac{\pm}{\pm}$
2 ⊗

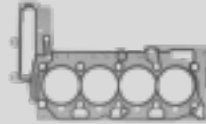

658.210
11 12 8 506 130
→
1,030 mm
→
1,180 mm



1,65 mm $\frac{\pm}{\pm}$
3 ⊗

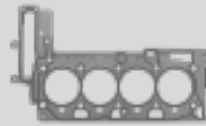











ZKS **233.370**
11 12 8 511 621 (10x)
M 12x1,5x200



ZKHS **530.060**
11 12 7 807 017

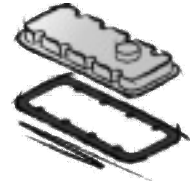
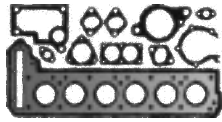

			<p>a) </p> <p>b) </p>	<p>K: </p> <p>N: </p>	
<p>VAS 530.070 11 34 7 807 347 539.420 FPM 16x</p>	<p>503.721 11 62 7 811 221 2x </p>	<p>529.960 11 61 7 801 439 4x </p>	<p>a) 030.793 Dirko HT a) 492.050 11 13 7 807 302 →04/2010 </p> <p>b) 455.740 11 13 7 535 106 +07 11 9 963 151 M 12x1,5x16 b) 110.906 07 11 9 963 151 CU A 12x17x1,5</p>	<p>K:← 584.160 11 11 7 802 665 AW/BS OF RD FPM 55x68x8 K:→ 492.060 11 14 7 797 490 AW/BS OF LD FPM 90x104x9</p>	

BMW**N47 D20 C**

4 Cyl. 1995 ccm
Cyl. 84,0 Ø

116 d (E81/87)

11/2008 → 12/2011

116 d (F20/21)

07/2011 →

118 d (E81/82/87/88)

09/2006 → 12/2013

118 d (F20/21)

07/2011 →

120 d (E81/82/87/88)

03/2007 → 12/2013

120 d (F20/21)

07/2011 →

218 d (F22/23)

03/2014 → 06/2015

220 d (F22/23)

10/2012 →

316 d (E90/91)

07/2009 → 06/2012

316 d (F30/31/35)

03/2012 → 06/2019

318 d (E90/91)

02/2007 → 06/2012

318 d (F30/31/34/35)

03/2012 → 06/2019

320 d (E90/91/92/93)

12/2004 → 12/2013

320 d (F30/31/34/35)

11/2011 → 06/2019

418 d (F32/36/82)

03/2014 → 12/2020

420 d (F32/33/36/82/83)

07/2013 →

518 d (F10/11/18)

07/2013 → 02/2017

520 d (E60/61)

04/2005 → 05/2010

520 d (F07/10/11/18)

06/2010 → 02/2017

520 d (F10/11/18)

06/2010 → 10/2016

523 d (F10/11/18)

06/2010 → 06/2014

X1 16 d (E84)

04/2012 → 06/2015

X1 18 d (E84)

03/2009 → 06/2015

X1 20 d (E84)

09/2009 → 06/2015

X3 18 d (E83)

09/2008 → 12/2011

X3 18 d (F25)

10/2012 → 03/2014

X3 20 d (E83)

09/2008 → 08/2010

X3 20 d (F25)

09/2010 → 03/2014

X3 28 d (F25)

04/2014 → 12/2016

ES⊕ **537.540**
11 12 7 807 293



ES⊕ **456.190**
N47N
X3 F25
520 d F07/10/11
518 d F07/10/11
420 d F36
320 d F30/31/34
220 d F22/23
120 d F20/21

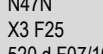

ES⊕ **522.180**
N47N

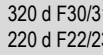

CS* **492.160**
11 11 7 807 292

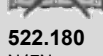

CS* **376.500**
N47N

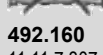

CS* **376.590**
N47N



CS* **376.590**
N47N



658.190
11 12 8 506 128
→ 0,920 mm



1,45 mm ±
1 ⊗

575.051
11 12 8 509 146
→ 0,920 mm

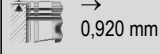

1,45 mm ± 84,7 Ø
1 ⊗
N47N

658.200
11 12 8 506 129
→ 0,920 mm
→ 1,030 mm



1,55 mm ±
2 ⊗

019.321
11 12 8 509 147
→ 0,920 mm
→ 1,030 mm

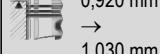

1,55 mm ± 84,7 Ø
2 ⊗
N47N

658.210
11 12 8 506 130
→ 1,030 mm
→ 1,180 mm



1,65 mm ±
3 ⊗

019.331
11 12 8 509 148
→ 1,030 mm
→ 1,180 mm



1,65 mm ± 84,7 Ø
3 ⊗
N47N

ZKS **233.370**
11 12 8 511 621 (10x)
M 12x1,5x200

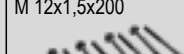



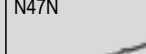











ZKHS **249.750**
11 12 8 511 814
N47N



ZKHS **530.060**
11 12 7 807 017



			<p>a) </p> <p>b) </p>	<p>K: </p> <p>N: </p>	
<p>VAS 530.070 11 34 7 807 347 539.420 FPM 16x</p>	<p>503.721 11 62 7 811 221 2x </p>	<p>529.960 11 61 7 801 439 4x </p>	<p>a) 030.793 Dirko HT a) 492.050 11 13 7 807 302 →04/2010 </p> <p>b) 455.740 11 13 7 535 106 +07 11 9 963 151 M 12x1,5x16 b) 110.906 07 11 9 963 151 CU A 12x17x1,5</p>	<p>K:← 584.160 11 11 7 802 665 AW/BS OF RD FPM 55x68x8 K:→ 492.060 11 14 7 797 490 AW/BS OF LD FPM 90x104x9</p>	<p>TLS 456.100 F30/34/36 F20/21/22 E90/91/92/93 E81/82/87/88 </p> <p>TLS 736.520 520 d F07/10/11 420 d F36 320 d F30/31/34 X3 F25 X1 (E84) 20 d →07/2013 </p> <p>TLS 259.930 420 d F36 520 d F07/10/11 320 d F30/31/34 X3 F25 X1 (E84) 20 d 07/2013→ </p>

BMW

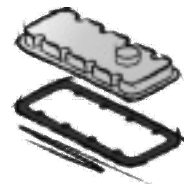
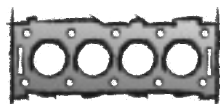
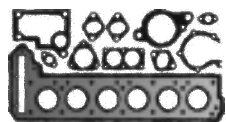

N47 D20 D

4 Cyl. 1995 ccm
Cyl. 84,0 Ø

123 d (E81/82/87/88)
03/2007 → 12/2013

125 d (F20/21)
12/2011 →

225 d (F22/23)
01/2014 →

325 d (F30/31/34/35)
03/2013 → 06/2016

425 d (F32/33/36/82/83)
03/2014 → 02/2016

525 d (F10/11/18)
09/2011 → 02/2017

X1 23 d (E84)
10/2009 → 06/2015

X1 25 d (E84)
10/2009 → 06/2015

X5 25 d (F15/85)
12/2013 → 07/2015

ES⊕ **530.140**
11 12 7 811 594



ES⊕ **456.200**
N47N



ES⊕ **522.180**
N47S1



CS* **492.160**
11 11 7 807 292

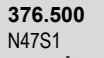

CS* **376.500**
N47S1



CS* **376.590**
N47S1



658.190

11 12 8 506 128



1,45 mm ±
1 ⊗

575.051

11 12 8 509 146

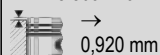

1,45 mm ± 84,7 Ø
1 ⊗

N47S1

658.200

11 12 8 506 129



1,55 mm ±
2 ⊗

019.321

11 12 8 509 147



1,55 mm ± 84,7 Ø
2 ⊗

N47S1

658.210

11 12 8 506 130



1,65 mm ±
3 ⊗

019.331

11 12 8 509 148



1,65 mm ± 84,7 Ø
3 ⊗

N47S1

ZKS 233.370

11 12 8 511 621 (10x)
M 12x1,5x200



ZKHS 249.750













11 12 8 511 814
N47S1



ZKHS 530.060

11 12 7 807 017

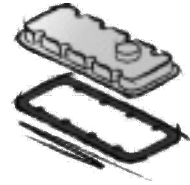

			<p>a) </p> <p>b) </p>	<p>K: </p> <p>N: </p>	
<p>VAS 530.070 11 34 7 807 347 539.420 FPM 16x</p>	<p>503.721 11 62 7 811 221 2x </p>	<p>529.960 11 61 7 801 439 4x </p>	<p>a) 030.793 Dirko HT</p> <p>a) 492.050 11 13 7 807 302 →04/2010 </p> <p>b) 455.740 11 13 7 535 106 +07 11 9 963 151 M 12x1,5x16</p> <p>b) 110.906 07 11 9 963 151 CU A 12x17x1,5</p>	<p>K:← 584.160 11 11 7 802 665 AW/BS OF RD FPM 55x68x8</p> <p>K:→ 492.060 11 14 7 797 490 AW/BS OF LD FPM 90x104x9</p>	<p>TLS 376.350 N47S1 </p>

BMW**N20 B20 A-C**

4 Cyl. 1997 ccm
Cyl. 84,0 Ø

120 i (F20/21)
03/2015 → 06/2016

125 i (F20/21)
12/2011 →

220 i (F22/23)
10/2013 →

228 i (F22/23)
01/2014 →

320 i (F30/31/34/35)
03/2012 → 10/2018

328 i (F30/31/34/35)
11/2011 → 10/2018

420 i (F32/33/36/82/83)
11/2013 → 02/2017

428 i (F32/33/36/82/83)
07/2013 → 02/2017

520 i (F10/11/18)
10/2010 → 02/2017

523 i (F10/11/18)
09/2011 → 10/2016

528 i (F07/10/11/18)
09/2011 → 02/2017

528 i (F10/11/18)
09/2011 → 02/2017

X1 20 i (E84)
09/2011 → 06/2015

X1 28 i (E84)
03/2011 → 06/2015

X3 20 i (F25)
10/2011 → 08/2017

X3 28 i (F25)
04/2012 → 08/2017

X4 20 i (F26)
04/2014 → 03/2018

X4 28 i (F26)
04/2014 → 03/2018

X5 28 i (F15/85)
06/2015 → 07/2018

X5 40 e (F15/85)
08/2015 → 07/2018

X6 28 i (F16/86)
06/2015 → 07/2019

Z4 18 i (E89)
04/2013 → 08/2016

Z4 20 i (E89)
09/2011 → 08/2016

Z4 28 i (E89)
09/2011 → 08/2016

ES⊕ **522.190**



CS* **793.020**



AL
CS* **389.700**



PLASTIC

364.525
11 12 7 620 697
0,70 mm $\frac{3}{4}$ 85,1 Ø

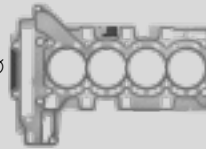

722.503
11 12 7 620 698
1,00 mm $\frac{3}{4}$ 85,1 Ø

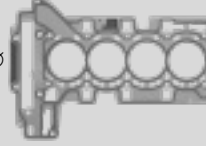

ZKS **426.890**
11 12 2 212 157
M 10x173 M 11x173
M9x30/70



ZKHS **054.930**
11 12 7 588 418



655.581
11 12 7 589 830
2x

**N20 B20 D**

4 Cyl. 1997 ccm
Cyl. 84,0 Ø

320 i (F30/31/34/35)
03/2012 → 10/2018

ES⊕ **522.190**



CS* **389.700**



PLASTIC

364.525
11 12 7 620 697
0,70 mm $\frac{3}{4}$ 85,1 Ø

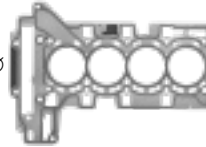

722.503
11 12 7 620 698
1,00 mm $\frac{3}{4}$ 85,1 Ø

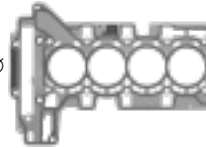

ZKS **426.890**
11 12 2 212 157
M 10x173 M 11x173
M9x30/70















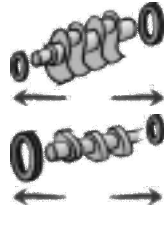







ZKHS **054.930**
11 12 7 588 418



655.581
11 12 7 589 830
2x



			<p>a) </p> <p>b) </p>	<p>K: </p> <p>N: </p>	
<p>VAS 308.970 11 34 0 038 719 FPM E</p> <p>VAS 308.630 11 34 0 038 720 FPM A</p>	<p>738.832 11 65 7 625 293 4x</p> 	<p>AAS 008.430 11 61 2 212 759</p> 	<p>a) 655.881 11 13 7 627 511</p>  <p>AL</p>  <p>a) 232.860 11 13 7 627 512</p>  <p>PLASTIC</p>  <p>b) 455.740 11 13 7 535 106 +07 11 9 963 151 M 12x1,5x16</p> <p>b) 642.110 PP/ACM 11 13 7 605 018</p>  <p>PLASTIC</p> <p>b) 110.906 07 11 9 963 151 CU A 12x17x1,5</p>	<p>K:← 902.860 11 11 8 618 864 ASW RD PTFE/ACM 65x79x10</p> <p>K:→ 751.610 11 11 7 587 168 AW OF LD FPM 90x110x8</p>	<p>TLS 306.350</p> 
<p>VAS 308.970 11 34 0 038 719 FPM E</p> <p>VAS 308.630 11 34 0 038 720 FPM A</p>	<p>738.832 11 65 7 625 293 4x</p> 	<p>AAS 008.430 11 61 2 212 759</p> 	<p>a) 232.860 11 13 7 627 512</p>  <p>PLASTIC</p>  <p>b) 642.110 PP/ACM 11 13 7 605 018</p>  <p>PLASTIC</p>	<p>K:← 902.860 11 11 8 618 864 ASW RD PTFE/ACM 65x79x10</p> <p>K:→ 751.610 11 11 7 587 168 AW OF LD FPM 90x110x8</p>	<p>TLS 306.350</p> 

BMW

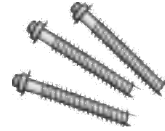
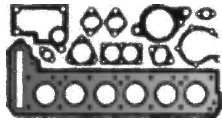

N26 B20 A

4 Cyl. **1997 ccm**
Cyl. 84,0 Ø

228 i (F22/23)
07/2014 →

328 i (F30/31/34/35)
11/2011 → 10/2018

428 i (F32/33/36/82/83)
07/2013 → 02/2017

CS* **793.020**



AL

CS* **389.700**



PLASTIC

364.525

11 12 7 620 697
0,70 mm \pm 85,1 Ø

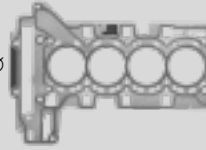

722.503

11 12 7 620 698
1,00 mm \pm 85,1 Ø

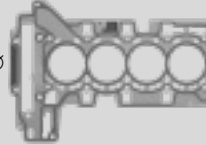

ZKS **426.890**

11 12 2 212 157
M 10x173 M 11x173
M9x30/70



ZKHS **054.930**

11 12 7 588 418



655.581

11 12 7 589 830
2x



N45 B20 A

4 Cyl. **1997 ccm**
Cyl. 85,0 Ø

















320 si (E90/91)
09/2005 → 08/2006

CS* **458.400**
11 11 7 511 529

131.660

11 12 7 557 933
1,00 mm \pm 87 Ø



			<p>a) </p> <p>b) </p>	<p>K: </p> <p>N: </p>	
<p>VAS 308.970 11 34 0 038 719 FPM E</p> <p>VAS 308.630 11 34 0 038 720 FPM A</p>	<p>738.832 11 65 7 625 293 4x</p> 	<p>AAS 008.430 11 61 2 212 759</p> 	<p>a) 655.881 11 13 7 627 511</p>  <p>AL</p>  <p>a) 232.860 11 13 7 627 512</p>  <p>PLASTIC</p>  <p>b) 455.740 11 13 7 535 106 +07 11 9 963 151 M 12x1,5x16</p> <p>b) 642.110 PP/ACM 11 13 7 605 018</p>  <p>PLASTIC</p> <p>b) 110.906 07 11 9 963 151 CU A 12x17x1,5</p>	<p>K:← 902.860 11 11 8 618 864 ASW RD PTFE/ACM 65x79x10</p> <p>K:→ 751.610 11 11 7 587 168 AW OF LD FPM 90x110x8</p>	<p>TLS 306.350</p> 
<p>476.691 11 34 1 340 849 FPM 16x</p>	<p>739.060 18 40 7 548 533</p>		<p>a) 190.640 11 13 7 511 224</p>  <p>b) 877.940 11 13 7 568 309 +07 11 9 963 150 M 12x1,5x10</p> <p>b) 068.616 07 11 9 963 150 AL A 12x17x1,5</p> <p>b) 110.906 07 11 9 963 151 CU A 12x17x1,5</p>	<p>K:← 257.400 11 11 7 511 395 ASW RD PTFE/ACM 65x79x20</p> <p>K:→ 257.770 11 11 7 511 396 ASW LD PTFE/ACM 90x110x12</p>	

BMW

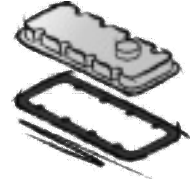
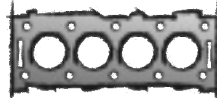
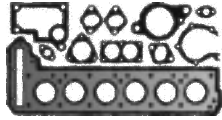

B42 S20 A

4 Cyl. 1998 ccm
Cyl. 82,0 Ø

- X1 20 i (F48)**
07/2015 →
- X1 25 i (F48)**
07/2015 →
- X2 20 i (F39)**
11/2017 →

ES **648.130**



CS* **794.660**

OKS **582.190**

11 42 8 591 461



796.280

11 12 8 654 272

0,70 mm $\frac{\pm}{\text{mm}}$ 82 Ø

597.170

11 12 8 654 273

1,00 mm $\frac{\pm}{\text{mm}}$ 82 Ø

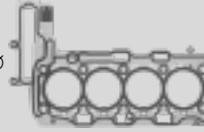

ZKS **577.230**

11 12 8 644 674 (10x)
M 11x1,5x88



593.300

11 12 8 618 519



B46 A20 B

4 Cyl. 1998 ccm
Cyl. 82,0 Ø

- 120 i (F40)**
03/2021 →
- 228 i (F44)**
11/2019 →
- X1 25 i (F48)**
07/2015 →
- X1 28 i (F48)**
11/2014 →
- X2 28 i (F39)**
11/2017 →

ES **648.130**



CS* **794.660**

OKS **582.190**

11 42 8 591 461



597.140

11 12 8 627 107

0,70 mm $\frac{\pm}{\text{mm}}$ 82 Ø

→07/2015

597.150

11 12 8 627 108

1,00 mm $\frac{\pm}{\text{mm}}$ 82 Ø

→07/2015

796.280

11 12 8 654 272

0,70 mm $\frac{\pm}{\text{mm}}$ 82 Ø

07/2015→

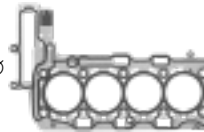

ZKS **577.230**











11 12 8 644 674 (10x)
M 11x1,5x88







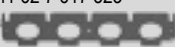



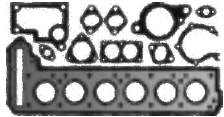
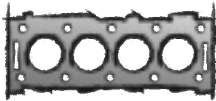

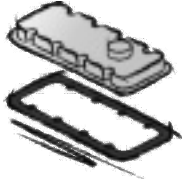

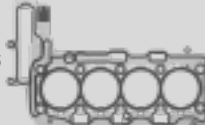

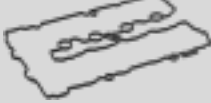

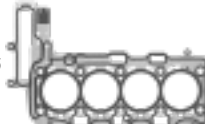



593.300

11 12 8 618 519

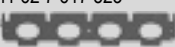

			<p>a) </p> <p>b) </p>	<p>K: </p> <p>N: </p>	
<p>VAS 308.970 11 34 0 038 719 FPM E</p> <p>VAS 308.630 11 34 0 038 720 FPM A</p>	<p>077.394 11 62 7 617 523</p> 	<p>572.700 11 61 7 633 493 4x</p>	<p>a) 036.164 11 12 1 262 571 Dirko HT / EU</p> <p>a) 510.031 11 12 1 262 571 Dirko HT / USA/CDN/MEX</p> <p>a) 527.291 11 12 1 262 571 Dirko HT / RU</p> <p>a) 648.661 11 12 1 262 571 Dirko HT / BR</p> <p>b) 455.740 11 13 7 535 106 +07 11 9 963 151 M 12x1,5x16</p> <p>b) 110.507 07 11 9 963 132 CU A 12x16x1</p>	<p>K:← 575.970 11 11 8 604 931 ASW RD PTFE/ACM 55x68x8</p> <p>K:→ 586.550 11 14 8 602 594 ASW LD PTFE 90x104x8,5</p>	
<p>VAS 308.970 11 34 0 038 719 FPM →06/2015 2x</p> <hr/> <p>06/2015→ E 1x</p> <p>VAS 308.630 11 34 0 038 720 FPM 06/2015→ A 1x</p>	<p>077.394 11 62 7 617 523</p> 	<p>572.700 11 61 7 633 493 4x</p>	<p>a) 036.164 11 12 1 262 571 Dirko HT / EU</p> <p>a) 510.031 11 12 1 262 571 Dirko HT / USA/CDN/MEX</p> <p>a) 527.291 11 12 1 262 571 Dirko HT / RU</p> <p>a) 648.661 11 12 1 262 571 Dirko HT / BR</p> <p>b) 455.740 11 13 7 535 106 +07 11 9 963 151 M 12x1,5x16</p> <p>b) 110.507 07 11 9 963 132 CU A 12x16x1</p>	<p>K:← 575.970 11 11 8 604 931 ASW RD PTFE/ACM 55x68x8</p> <p>K:→ 586.550 11 14 8 602 594 ASW LD PTFE 90x104x8,5</p>	

BMW 				
B46 B20 B 4 Cyl. 1998 ccm Cyl. 82,0 Ø 230 i (F22/23) 07/2016 → 320 i G20/21) 11/2019 → 330 e (G20/21) 07/2019 → 330 i (F30/31/34/35) 07/2015 → 330 i (G20/21) 11/2018 → 420 i (G22/23) 07/2020 → 420 i (G26) 07/2021 → 430 i (F32/33/36/82/83) 03/2016 → 430 i (G22/23) 07/2020 → 430 i (G26) 07/2021 → 530 e (G30/31) 03/2017 → 530 i (G30/31) 09/2016 → 06/2020 X3 20 i (G01) 08/2021 → X3 30 e (G01) 12/2019 → X3 30 i (G01) 08/2017 → X4 20 i (G02) 08/2021 → X4 30 i (G02) 04/2018 → Z4 20 i (G29) 11/2018 → Z4 30 i (G29) 11/2018 →	ES⊕ 444.970  CS* 794.680 OKS 634.970 11 42 8 591 462 	796.280 11 12 8 654 272 0,70 mm $\frac{\pm}{\pm}$ 82 Ø  597.170 11 12 8 654 273 1,00 mm $\frac{\pm}{\pm}$ 82 Ø	ZKS 794.470 11 12 8 644 675 (10x) M 11x1,5x188 	593.300 11 12 8 618 519 
B48 A20 A 4 Cyl. 1998 ccm Cyl. 82,0 Ø 120 i (F40) 11/2020 → 220 i (F44) 07/2020 → 220 i (F45/46) 03/2014 → X1 20 i (F48) 07/2015 → X2 20 i (F39) 11/2017 →	ES 648.130  CS* 794.660 OKS 582.190 11 42 8 591 461 	597.140 11 12 8 627 107 0,70 mm $\frac{\pm}{\pm}$ 82 Ø →07/2015 597.150 11 12 8 627 108 1,00 mm $\frac{\pm}{\pm}$ 82 Ø →07/2015 796.280 11 12 8 654 272 0,70 mm $\frac{\pm}{\pm}$ 82 Ø 07/2015→  597.170 11 12 8 654 273 1,00 mm $\frac{\pm}{\pm}$ 82 Ø 07/2015→	ZKS 577.230 11 12 8 644 674 (10x) M 11x1,5x88 	593.300 11 12 8 618 519 

			<p>a) </p> <p>b) </p>	<p>K: </p> <p>N: </p>	
<p>VAS 308.970 11 34 0 038 719 FPM E</p> <p>VAS 308.630 11 34 0 038 720 FPM A</p>	<p>077.394 11 62 7 617 523</p> 		<p>a) 036.164 11 12 1 262 571 Dirko HT / EU</p> <p>a) 510.031 11 12 1 262 571 Dirko HT / USA/CDN/MEX</p> <p>a) 527.291 11 12 1 262 571 Dirko HT / RU</p> <p>a) 648.661 11 12 1 262 571 Dirko HT / BR</p> <p>b) 455.740 11 13 7 535 106 +07 11 9 963 151 M 12x1,5x16</p> <p>b) 110.507 07 11 9 963 132 CU A 12x16x1</p>	<p>K:← 575.970 11 11 8 604 931 ASW RD PTFE/ACM 55x68x8</p> <p>K:→ 586.550 11 14 8 602 594 ASW LD PTFE 90x104x8,5</p>	<p>TLS 085.550</p>
<p>VAS 308.970 11 34 0 038 719 FPM →06/2015 2x</p> <hr/> <p>06/2015→ E 1x</p> <p>VAS 308.630 11 34 0 038 720 FPM 06/2015→ A 1x</p>	<p>077.394 11 62 7 617 523</p>  <p>592.380 11 65 8 631 900</p>	<p>572.700 11 61 7 633 493 F39 F48 F46 4x</p>	<p>a) 036.164 11 12 1 262 571 Dirko HT / EU</p> <p>a) 510.031 11 12 1 262 571 Dirko HT / USA/CDN/MEX</p> <p>a) 527.291 11 12 1 262 571 Dirko HT / RU</p> <p>a) 648.661 11 12 1 262 571 Dirko HT / BR</p> <p>b) 455.740 11 13 7 535 106 +07 11 9 963 151 M 12x1,5x16</p> <p>b) 110.507 07 11 9 963 132 CU A 12x16x1</p>	<p>K:← 575.970 11 11 8 604 931 ASW RD PTFE/ACM 55x68x8</p> <p>K:→ 586.550 11 14 8 602 594 ASW LD PTFE 90x104x8,5</p>	

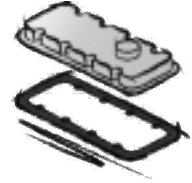
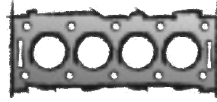
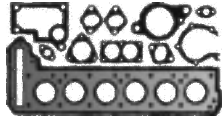
BMW**B48 A20 B**

4 Cyl. 1998 ccm
Cyl. 82,0 Ø

128 ti (F40)

11/2020 →

220 i (F45/46)

01/2017 →

225 i (F45/46)

11/2013 →

X1 20 i (F48)

07/2015 → 11/2015

X1 25 i (F48)

07/2015 →

ES **648.130**CS* **794.660**OKS **582.190**

11 42 8 591 461

**597.140**

11 12 8 627 107

0,70 mm $\frac{3}{4}$ 82 Ø

→07/2015

597.150

11 12 8 627 108

1,00 mm $\frac{3}{4}$ 82 Ø

→07/2015

796.280

11 12 8 654 272

0,70 mm $\frac{3}{4}$ 82 Ø

07/2015 →

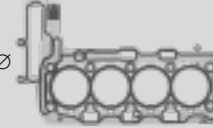
**597.170**

11 12 8 654 273

1,00 mm $\frac{3}{4}$ 82 Ø

07/2015 →

ZKS **577.230**

11 12 8 644 674 (10x)

M 11x1,5x88

**593.300**

11 12 8 618 519

**B48 A20 C**

4 Cyl. 1998 ccm
Cyl. 82,0 Ø

120 i (F52)

06/2018 →

220 i (F44)

07/2020 →

ES **648.130**CS* **794.660**OKS **582.190**

11 42 8 591 461

**796.280**

11 12 8 654 272

0,70 mm $\frac{3}{4}$ 82 Ø

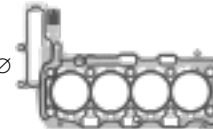
**597.170**

11 12 8 654 273

1,00 mm $\frac{3}{4}$ 82 Ø

ZKS **577.230**











11 12 8 644 674 (10x)

M 11x1,5x88

**593.300**

11 12 8 618 519

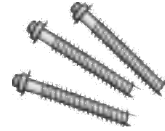
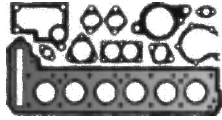

			<p>a) </p> <p>b) </p>	<p>K: </p> <p>N: </p>	
<p>VAS 308.970 11 34 0 038 719 FPM →06/2015 2x</p> <hr/> <p>06/2015→ E 1x</p> <p>VAS 308.630 11 34 0 038 720 FPM 06/2015→ A 1x</p>	<p>077.394 11 62 7 617 523</p> 	<p>572.700 11 61 7 633 493 F48 F45 4x</p>	<p>a) 036.164 11 12 1 262 571 Dirko HT / EU</p> <p>a) 510.031 11 12 1 262 571 Dirko HT / USA/CDN/MEX</p> <p>a) 527.291 11 12 1 262 571 Dirko HT / RU</p> <p>a) 648.661 11 12 1 262 571 Dirko HT / BR</p> <p>b) 455.740 11 13 7 535 106 +07 11 9 963 151 M 12x1,5x16</p> <p>b) 110.507 07 11 9 963 132 CU A 12x16x1</p>	<p>K:← 575.970 11 11 8 604 931 ASW RD PTFE/ACM 55x68x8</p> <p>K:→ 586.550 11 14 8 602 594 ASW LD PTFE 90x104x8,5</p>	
<p>VAS 308.970 11 34 0 038 719 FPM →06/2015 2x</p> <hr/> <p>06/2015→ E 1x</p> <p>VAS 308.630 11 34 0 038 720 FPM 06/2015→ A 1x</p>	<p>077.394 11 62 7 617 523</p> 		<p>a) 036.164 11 12 1 262 571 Dirko HT / EU</p> <p>a) 510.031 11 12 1 262 571 Dirko HT / USA/CDN/MEX</p> <p>a) 527.291 11 12 1 262 571 Dirko HT / RU</p> <p>a) 648.661 11 12 1 262 571 Dirko HT / BR</p> <p>b) 455.740 11 13 7 535 106 +07 11 9 963 151 M 12x1,5x16</p> <p>b) 110.507 07 11 9 963 132 CU A 12x16x1</p>	<p>K:← 575.970 11 11 8 604 931 ASW RD PTFE/ACM 55x68x8</p> <p>K:→ 586.550 11 14 8 602 594 ASW LD PTFE 90x104x8,5</p>	

BMW**B48 B20 A**

4 Cyl. 1998 ccm
Cyl. 82,0 Ø

- 120 i (F20/21)**
07/2016 →
- 220 i (F22/23)**
09/2015 →
- 220 i (G42)**
08/2021 →
- 225 i (F22/23)**
10/2017 →
- 318 i (G20/21)**
03/2020 →
- 320 e (G20/21)**
07/2020 →
- 320 i (F30/31/34/35)**
07/2015 →
- 320 i (G20/21)**
03/2019 →
- 330 e (F30/31/35)**
11/2015 → 10/2018
- 330 e (G20/21)**
07/2019 →
- 330 i (F30/31/34/35)**
07/2015 → 06/2019
- 420 i (F32/33/36/82/83)**
03/2016 →
- 420 i (G22/23)**
07/2020 →
- 420 i (G26)**
07/2021 →
- 425 i (F32/33/36/82/83)**
06/2017 →
- 520 e (G30/31)**
03/2021 →
- 520 i (G30/31)**
07/2017 →
- 523 i (G30/31)**
07/2017 → 06/2020
- 525 i (G30/31)**
07/2017 → 06/2020
- 530 e (G30/31)**
03/2017 →
- X3 20 i (G01)**
12/2017 →
- X3 30 e (G01)**
12/2019 →
- X4 20 i (G02)**
04/2018 →

ES⊕ **444.970**CS* **794.680**OKS **634.970**

11 42 8 591 462

**796.280**

11 12 8 654 272

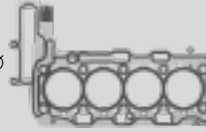
0,70 mm $\frac{\pm}{\text{mm}}$ 82 Ø**597.170**

11 12 8 654 273

1,00 mm $\frac{\pm}{\text{mm}}$ 82 ØZKS **794.470**









11 12 8 644 675 (10x)

M 11x1,5x188

**593.300**

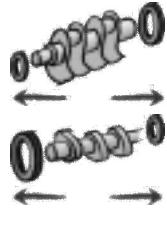
11 12 8 618 519

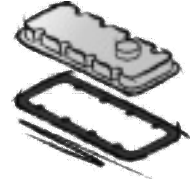
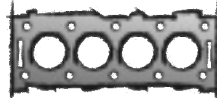
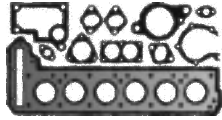

			<p>a) </p> <p>b) </p>	<p>K: </p> <p>N: </p>	
<p>VAS 308.970 11 34 0 038 719 FPM E</p> <p>VAS 308.630 11 34 0 038 720 FPM A</p>	<p>077.394 11 62 7 617 523</p>  <p>588.371 11 62 8 642 774 B48D</p>  <p>592.380 11 65 8 631 900 B48D</p>	<p>087.240 5P31/32 6K31/32 JR11/12 JT11/12 TS71/72/76 TY11/12/15/16 UJ71/72 5F31/32/38 4x</p>	<p>a) 036.164 11 12 1 262 571 Dirko HT / EU</p> <p>a) 510.031 11 12 1 262 571 Dirko HT / USA/CDN/MEX</p> <p>a) 527.291 11 12 1 262 571 Dirko HT / RU</p> <p>a) 648.661 11 12 1 262 571 Dirko HT / BR</p> <p>b) 455.740 11 13 7 535 106 +07 11 9 963 151 M 12x1,5x16</p> <p>b) 110.507 07 11 9 963 132 CU A 12x16x1</p>	<p>K:← 575.970 11 11 8 604 931 ASW RD PTFE/ACM 55x68x8</p> <p>K:→ 586.550 11 14 8 602 594 ASW LD PTFE 90x104x8,5</p>	<p>TLS 085.550 TLS 085.560 B48D TLS 087.270 B48D</p>

BMW**B48 B20 B**

4 Cyl. 1998 ccm
Cyl. 82,0 Ø

- 125 i (F20/21)**
10/2015 →
- 230 i (F22/23)**
07/2016 →
- 230 i (G42)**
08/2021 →
- 320 i (G20/21)**
03/2019 →
- 330 e (G20/21)**
07/2019 →
- 330 i (F30/31/34/35)**
07/2015 →
- 330 i (G20/21)**
11/2018 →
- 430 i (F32/33/36/82/83)**
03/2016 →
- 430 i (G22/23)**
07/2020 →
- 430 i (G26)**
07/2021 →
- 520 i (G30/31)**
07/2017 → 06/2020
- 525 i (G30/31)**
07/2017 → 06/2020
- 530 i (G30/31)**
09/2016 →
- 630 i (G32)**
06/2017 →
- 730 i (G11/12)**
11/2015 →
- 740 e (G11/12)**
07/2016 → 02/2019
- X3 20 i (G01)**
12/2017 →
- X3 30 i (G01)**
08/2017 →
- X4 30 i (G02)**
04/2018 →
- X5 30 i (G05)**
09/2019 →
- X6 30 i (G06)**
11/2019 →
- Z4 20 i (G29)**
11/2018 →
- Z4 30 i (G29)**
11/2018 →

ES⊕ **444.970**CS* **794.680**OKS **634.970**

11 42 8 591 462

**796.280**

11 12 8 654 272
0,70 mm $\frac{\pm}{\text{mm}}$ 82 Ø

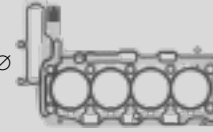
**597.170**

11 12 8 654 273
1,00 mm $\frac{\pm}{\text{mm}}$ 82 Ø









ZKS **794.470**

11 12 8 644 675 (10x)
M 11x1,5x188

**593.300**

11 12 8 618 519

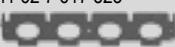

			<p>a) </p> <p>b) </p>	<p>K: </p> <p>N: </p>	
<p>VAS 308.970 11 34 0 038 719 FPM E</p> <p>VAS 308.630 11 34 0 038 720 FPM A</p>	<p>077.394 11 62 7 617 523</p> 	<p>087.240 JR11/12 JT11/12 TS71/72/76 TY11/12/15/16 4x</p>	<p>a) 036.164 11 12 1 262 571 Dirko HT / EU</p> <p>a) 510.031 11 12 1 262 571 Dirko HT / USA/CDN/MEX</p> <p>a) 527.291 11 12 1 262 571 Dirko HT / RU</p> <p>a) 648.661 11 12 1 262 571 Dirko HT / BR</p> <p>b) 455.740 11 13 7 535 106 +07 11 9 963 151 M 12x1,5x16</p> <p>b) 110.507 07 11 9 963 132 CU A 12x16x1</p>	<p>K:← 575.970 11 11 8 604 931 ASW RD PTFE/ACM 55x68x8</p> <p>K:→ 586.550 11 14 8 602 594 ASW LD PTFE 90x104x8,5</p>	<p>TLS 085.550</p>

BMW

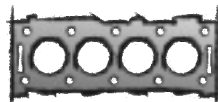
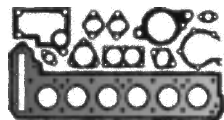

M54 B22 (226S1)

6 Cyl. 2171 ccm
Cyl. 80,0 Ø

320 Ci (E46)

01/2000 → 12/2007

320 i (E46)

09/2000 → 02/2005

520 i (E39)

09/2000 → 12/2003

520 i (E60/61)

07/2003 → 03/2010

Z3 (E36)

08/2000 → 01/2003

Z4 2.2 i (E85)

10/2003 → 10/2005

ES⊕ **366.530**
11 12 7 507 597
→09/2002



ES⊕ **903.340**
RHD
→09/2002



ES⊕ **382.800**
11 12 0 141 055
10/2002→



ES⊕ **903.350**
RHD
10/2002→



CS* **359.160**
11 11 1 432 478

154.980
11 12 7 506 983
0,70 mm $\frac{1}{4}$ 81 Ø



373.180
11 12 7 506 984
1,00 mm $\frac{1}{4}$ 81 Ø



ZKS **802.820**
11 12 1 740 065
M 10x1,5x110



ZKHS **318.590**
11 12 9 070 990
+11 12 1 437 395 (15x)
→09/2002



ZKHS **326.560**
11 12 9 070 990
→09/2002



ZKHS **318.600**
11 12 0 030 496
+11 12 1 437 395 (15x)
10/2002→



ZKHS **382.750**
11 12 0 030 496
10/2002→



425.390
11 12 1 748 872
→09/2002

2x



436.010
11 12 1 437 395
15x



S14 B23 (234EA)/(234S1)/ (234S2)

S14 B23 (EVO I)

4 Cyl. 2302 ccm
Cyl. 93,4 Ø

M3 2.3 (E30)

01/1986 → 10/1993

M3 EVO I 2.3 (E30)

10/1988 → 10/1990

ES⊕ **893.773**
11 12 1 316 992

CS* **893.781**
11 11 1 316 993

893.765
11 12 1 316 714
1,82 mm $\frac{1}{4}$ 94 Ø

















762.041
11 12 1 312 171

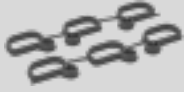
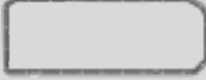

755.991
11 12 1 304 329
2x



			<p>a) </p> <p>b) </p>	<p>K: </p> <p>N: </p>	
<p>VAS 424.820 FPM 403.730 11 34 2 245 151 FPM 24x</p>	<p>326.250 11 62 1 732 969 Euro 2 / Euro 3 (D3) 2x </p> <p>738.340 RHD 11 62 7 522 585 2x </p>	<p>AAS 366.500 11 61 1 436 631 </p>	<p>a) 424.510 11 13 9 065 875 </p> <p>b) 774.390 11 13 1 273 093 M 12x1,5x18</p> <p>b) 110.906 07 11 9 963 151 CU A 12x17x1,5</p> <p>b) 238.708 07 11 9 963 130 AL A 12x15,5x1,5</p>	<p>K:← 050.260 11 14 2 249 532 AS RD PTFE/ACM 48x65x10</p> <p>K:→ 301.870 11 14 2 249 533 A/BS LD PTFE/FPM 90x110x12</p> <p>K:→ 702.994 11 14 1 706 999 A/BS LD FPM 90x110x12</p>	
<p>VAS 825.042 11 34 9 059 171 FPM 2x 701.289 11 34 1 706 707 FPM 16x</p>	<p>762.016 11 62 1 312 992 4x </p>		<p>a) 835.099 11 13 1 727 974 ↑ </p> <p>a) 329.606 11 13 1 727 983 </p> <p>b) 774.390 11 13 1 273 093 M 12x1,5x18</p> <p>b) 238.708 07 11 9 963 130 AL A 12x15,5x1,5</p>	<p>K:← 761.796 11 14 1 721 560 AW/BS RD FPM 44x60x10</p> <p>K:→ 301.870 11 14 2 249 533 A/BS LD PTFE/FPM 90x110x12</p> <p>K:→ 702.994 11 14 1 706 999 A/BS LD FPM 90x110x12</p> <p>N:← 562.939 11 14 1 707 107 AW RD FPM 28x40x7</p>	

BMW

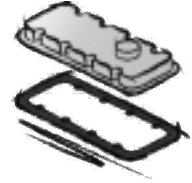
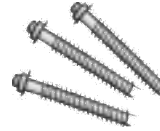
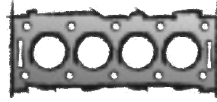
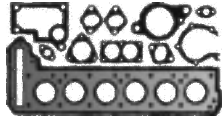

**M20 B23 (236EA)/(236EB)/
(236EC)/(236EW)**

6 Cyl. **2316 ccm**
Cyl. 80,0 Ø

323 i (E21)
01/1978 → 10/1982
323 i (E30)
09/1982 → 09/1986

ES⊕ **147.360**
incl. 829.994
11 12 1 730 876
E30
ES⊕ **817.384**
11 12 1 730 876
E30
ES⊕ **820.911**
11 12 9 059 248
E21
CS* **892.106**
11 11 9 063 134

829.986
11 12 1 738 609
1,88 mm $\frac{\pm}{\text{mm}}$ 81 Ø
829.994
11 12 1 738 611
2,08 mm $\frac{\pm}{\text{mm}}$ 81 Ø



ZKS **820.229**
11 12 1 726 478
M 10x1,5x150



774.693
11 12 1 730 271



M21 D24 (246DA)/(246DB)/W

6 Cyl. **2443 ccm**
Cyl. 80,0 Ø

324 d (E30)
09/1985 → 12/1990
524 d (E28)
03/1986 → 12/1987

ES⊕ **892.177**
11 12 2 243 877





















893.617
11 12 2 244 727
0,640 mm
→
0,810 mm
1,55 mm $\frac{\pm}{\text{mm}}$ 81 Ø



462.950
11 12 1 285 973



BMW

			<p>a) </p> <p>b) </p>	<p>K: </p> <p>N: </p>	
<p>VAS 825.050 11 34 9 059 172 FPM</p> <p>701.289 11 34 1 706 707 FPM 12x</p>	<p>495.900 11 62 1 728 489 E30 2x</p>  <p>888.516 11 62 1 723 877 E21 6x</p> 	<p>774.553 11 61 1 726 010 E30 4x</p>  <p>774.561 11 61 1 726 012 E30</p>  <p>776.602 11 61 1 730 787 E21 4x</p>  <p>810.851 11 61 1 730 743 E21</p> 	<p>a) 888.346 11 13 1 730 234</p>  <p>b) 774.390 11 13 1 273 093 M 12x1,5x18</p> <p>b) 238.708 07 11 9 963 130 AL A 12x15,5x1,5</p>	<p>K:← 586.676 11 14 1 275 466 A/BS RD FPM 48x65x10</p> <p>K:→ 301.870 11 14 2 249 533 A/BS LD PTFE/FPM 90x110x12</p> <p>K:→ 702.994 11 14 1 706 999 A/BS LD FPM 90x110x12</p> <p>N:← 586.668 11 12 1 285 609 ASW WD FPM 38x50x7</p>	
<p>VAS 825.050 11 34 9 059 172 FPM</p> <p>701.289 11 34 1 706 707 FPM 12x</p>	<p>811.386 11 62 2 243 884</p> 	<p>811.319 11 61 2 243 867 3x</p> 	<p>a) 888.346 11 13 1 730 234</p>  <p>b) 455.740 11 13 7 535 106 +07 11 9 963 151 M 12x1,5x16</p> <p>b) 774.390 11 13 1 273 093 M 12x1,5x18</p> <p>b) 110.906 07 11 9 963 151 CU A 12x17x1,5</p> <p>b) 238.708 07 11 9 963 130 AL A 12x15,5x1,5</p>	<p>K:← 586.676 11 14 1 275 466 A/BS RD FPM 48x65x10</p> <p>K:→ 301.870 11 14 2 249 533 A/BS LD PTFE/FPM 90x110x12</p> <p>K:→ 702.994 11 14 1 706 999 A/BS LD FPM 90x110x12</p> <p>N:← 586.668 11 12 1 285 609 ASW WD FPM 38x50x7</p>	

BMW

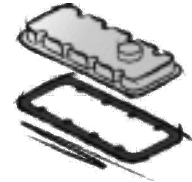
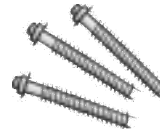
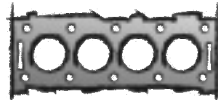
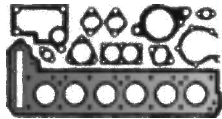

M21 D24 (246TA)/(246TB)

6 Cyl. **2443 ccm**
Cyl. 80,0 Ø

324 td (E30)
09/1987 → 06/1993
524 td (E28)
09/1983 → 12/1987
524 td (E34)
03/1988 → 08/1991

893.617
11 12 2 244 727
 0,640 mm
→
0,810 mm
1,55 mm $\frac{1}{2}$ 81 Ø



462.950
11 12 1 285 973

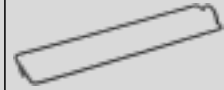

**M20 B25 (256E1)/(256E2)/
(256EX)/(256K1)**

6 Cyl. **2494 ccm**
Cyl. 84,0 Ø

325 i (E30)
09/1983 → 11/1993
525 i (E34)
02/1988 → 08/1990
Z1
06/1988 → 06/1991

ES⊕ **444.450**
incl. 567.818
ES⊕ **818.747**
11 12 9 059 240
CS* **892.106**
11 11 9 063 134

694.011
11 12 1 722 737
1,75 mm $\frac{1}{2}$ 85 Ø
567.818
11 12 1 722 738
2,05 mm $\frac{1}{2}$ 85 Ø



ZKS 820.229
11 12 1 726 478
M 10x1,5x150



774.693
11 12 1 730 271



**M30 B25
M30 B25 (256EA)/(256VA)/A**

6 Cyl. **2494 ccm**
Cyl. 86,0 Ø

2.5 CS (E9)
09/1974 → 03/1976
2500 (E3)
10/1968 → 04/1977
525 (E12)
10/1973 → 06/1981
525 i (E28)
06/1981 → 12/1987
725 i (E23)
07/1977 → 06/1986



















CS* **888.389**
11 11 1 735 046

772.976
11 12 1 730 746
1,72 mm $\frac{1}{2}$ 88 Ø
772.984
11 12 1 730 748
2,07 mm $\frac{1}{2}$ 88 Ø

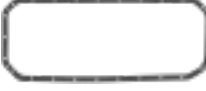

774.936 ●
11 12 1 730 935



			<p>a) </p> <p>b) </p>	<p>K: </p> <p>N: </p>	
<p>VAS 825.050 11 34 9 059 172 FPM</p> <p>701.289 11 34 1 706 707 FPM 12x</p>	<p>833.274 11 62 2 243 782 6x</p> 	<p>811.319 11 61 2 243 867 3x</p> 	<p>a) 888.346 11 13 1 730 234</p>  <p>b) 455.740 11 13 7 535 106 +07 11 9 963 151 M 12x1,5x16</p> <p>b) 774.390 11 13 1 273 093 M 12x1,5x18</p> <p>b) 110.906 07 11 9 963 151 CU A 12x17x1,5</p> <p>b) 238.708 07 11 9 963 130 AL A 12x15,5x1,5</p>	<p>K:← 586.676 11 14 1 275 466 A/BS RD FPM 48x65x10</p> <p>K:→ 301.870 11 14 2 249 533 A/BS LD PTFE/FPM 90x110x12</p> <p>K:→ 702.994 11 14 1 706 999 A/BS LD FPM 90x110x12</p> <p>N:← 586.668 11 12 1 285 609 ASW WD FPM 38x50x7</p>	
<p>VAS 825.050 11 34 9 059 172 FPM</p> <p>701.289 11 34 1 706 707 FPM 12x</p>	<p>495.900 11 62 1 728 489 2x</p> 	<p>774.553 11 61 1 726 010 4x</p>  <p>774.561 11 61 1 726 012</p> 	<p>a) 888.346 11 13 1 730 234</p>  <p>b) 774.390 11 13 1 273 093 M 12x1,5x18</p> <p>b) 238.708 07 11 9 963 130 AL A 12x15,5x1,5</p>	<p>K:← 586.676 11 14 1 275 466 A/BS RD FPM 48x65x10</p> <p>K:→ 301.870 11 14 2 249 533 A/BS LD PTFE/FPM 90x110x12</p> <p>K:→ 702.994 11 14 1 706 999 A/BS LD FPM 90x110x12</p> <p>N:← 586.668 11 12 1 285 609 ASW WD FPM 38x50x7</p>	
<p>187.666 11 34 1 256 556 FPM 12x</p>	<p>891.991 11 62 1 723 851 6x</p> 	<p>892.130 11 61 9 065 676 6x</p> 	<p>a) 888.354 11 13 1 730 240</p>  <p>b) 774.390 11 13 1 273 093 M 12x1,5x18</p> <p>b) 110.906 07 11 9 963 151 CU A 12x17x1,5</p> <p>b) 238.708 07 11 9 963 130 AL A 12x15,5x1,5</p> <p>b) 250.007 07 11 9 963 355 AL A 22x27x1,5</p>	<p>K:← 586.641 11 14 1 715 101 AW/BS RD FPM 42x62x12</p> <p>K:→ 301.870 11 14 2 249 533 A/BS LD PTFE/FPM 90x110x12</p> <p>K:→ 702.994 11 14 1 706 999 A/BS LD FPM 90x110x12</p>	

BMW

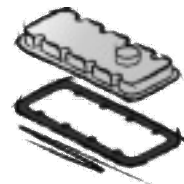
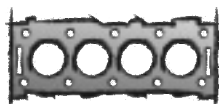
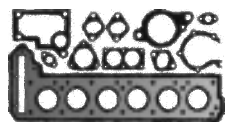

M50 B25 (256S1)

6 Cyl. **2494 ccm**
Cyl. 84,0 Ø

325 i (E36)

09/1990 → 12/1995

525 i (E34)

03/1990 → 07/1996

ES⊕ **444.360**
incl. 914.495
11 12 1 730 253
→09/1992

ES⊕ **893.846**
11 12 1 730 253
→09/1992

ES⊕ **444.370**
incl. 914.495
11 12 9 064 467
10/1992→

ES⊕ **445.300**
11 12 9 064 467
10/1992→

CS* **816.982**
11 11 1 730 251
→09/1992

CS* **424.770**
11 11 9 064 460
10/1992→

893.812
11 12 1 726 617
1,75 mm $\frac{1}{16}$ 85 Ø

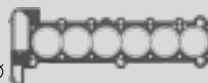

914.495
11 12 1 726 620
2,05 mm $\frac{1}{16}$ 85 Ø

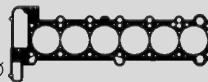

ZKS **802.740**
11 12 1 721 938
M 10x1,5x95



ZKHS **302.320**
11 12 9 070 530
→09/1992



ZKHS **302.340**
11 12 0 034 107
10/1992→



ZKHS **318.550**
11 12 0 034 107
+11 12 1 437 395 (15x)
10/1992→



891.312
11 12 1 748 049
→09/1992



147.610
11 12 1 738 701
10/1992→





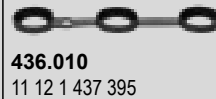







827.312
11 12 1 735 721
2x

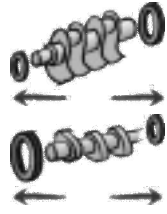

436.010
11 12 1 437 395
15x

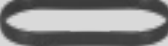

BMW

			<p>a) </p> <p>b) </p>	<p>K: </p> <p>N: </p>	
<p>VAS 825.050 11 34 9 059 172 FPM →09/1992 2x</p> <p>VAS 424.820 FPM 10/1992→</p> <p>701.289 11 34 1 706 707 FPM →09/1992 24x</p> <p>403.730 11 34 2 245 151 FPM 10/1992→ 24x</p>	<p>821.020 11 62 1 728 983 3x</p> 	<p>888.605 11 61 1 717 259 6x</p> 	<p>a) 811.653 11 13 1 720 519 →09/1992</p>  <p>a) 424.510 11 13 9 065 875 10/1992→</p>  <p>b) 774.390 11 13 1 273 093 M 12x1,5x18</p> <p>b) 238.708 07 11 9 963 130 AL A 12x15,5x1,5</p>	<p>K:← 586.676 11 14 1 275 466 A/BS RD FPM 48x65x10</p> <p>K:→ 301.870 11 14 2 249 533 A/BS LD PTFE/FPM 90x110x12</p> <p>K:→ 702.994 11 14 1 706 999 A/BS LD FPM 90x110x12</p>	

BMW

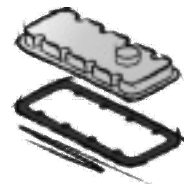
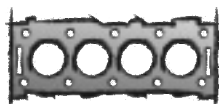
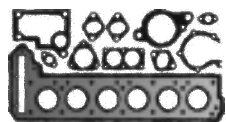

M50 B25 (256S2)

6 Cyl. **2494 ccm**
Cyl. 84,0 Ø

325 i (E36)

09/1990 → 12/1995

525 i (E34)

03/1990 → 07/1996

ES⊕ **444.370**
incl. 914.495
11 12 9 064 467
ES⊕ **445.300**
11 12 9 064 467
CS* **424.770**
11 11 9 064 460

893.812
11 12 1 726 617
1,75 mm $\frac{1}{16}$ 85 Ø

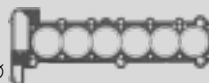

914.495
11 12 1 726 620
2,05 mm $\frac{1}{16}$ 85 Ø

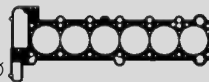

ZKS **802.740**
11 12 1 721 938
M 10x1,5x95



ZKHS **302.340**
11 12 0 034 107



ZKHS **318.550**
11 12 0 034 107
+11 12 1 437 395 (15x)



147.610
11 12 1 738 701













827.312
11 12 1 735 721
2x



436.010
11 12 1 437 395
15x

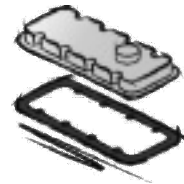
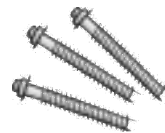
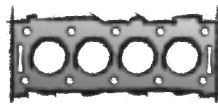
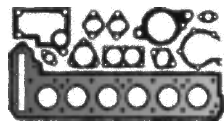

			<p>a) </p> <p>b) </p>	<p>K: </p> <p>N: </p>	
<p>VAS 424.820 FPM 403.730 11 34 2 245 151 FPM 24x</p>	<p>821.020 11 62 1 728 983 3x </p>	<p>888.605 11 61 1 717 259 6x </p>	<p>a) 424.510 11 13 9 065 875 </p> <p>b) 774.390 11 13 1 273 093 M 12x1,5x18</p> <p>b) 238.708 07 11 9 963 130 AL A 12x15,5x1,5</p>	<p>K:← 586.676 11 14 1 275 466 A/BS RD FPM 48x65x10</p> <p>K:→ 301.870 11 14 2 249 533 A/BS LD PTFE/FPM 90x110x12</p> <p>K:→ 702.994 11 14 1 706 999 A/BS LD FPM 90x110x12</p>	

BMW**M52 B25 (256S3)**

6 Cyl. **2494 ccm**
Cyl. 84,0 Ø

323 i (E36)

05/1995 → 11/1999

323 i (E46)

10/1999 → 12/2000

323 ti (E36)

09/1997 → 08/2000

523 i (E39)

09/1995 → 08/2000

ES⊕ **147.600**
11 12 1 740 984
→09/1995

ES⊕ **444.440**
incl. 914.495
11 12 1 427 826
10/1995→
→09/1998

ES⊕ **445.470**
11 12 1 427 826
10/1995→
→09/1998

ES⊕ **366.560**
11 12 1 436 822
+11 62 1 732 969 (2x)
09/1998→



ES⊕ **905.590**
11 12 1 436 822
+11 62 1 732 969 (2x)
+11 12 7 501 304
09/1998→

CS* **424.901**
11 11 1 740 981
→09/1998

CS* **359.160**
11 11 1 432 478
09/1998→

893.812
11 12 1 726 617
1,75 mm $\frac{\pm}{\pm}$ 85 Ø
→09/1998

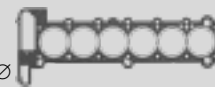

914.495
11 12 1 726 620
2,05 mm $\frac{\pm}{\pm}$ 85 Ø
→09/1998



361.473
11 12 7 501 304
0,70 mm $\frac{\pm}{\pm}$ 85 Ø
09/1998→



361.503
11 12 7 501 305
1,00 mm $\frac{\pm}{\pm}$ 85 Ø
09/1998→



ZKS **802.740**
11 12 1 721 938
M 10x1,5x95



ZKS **802.820**
11 12 1 740 065
M 10x1,5x110



ZKHS **302.340**
11 12 0 034 107
→09/1995



ZKHS **318.550**
11 12 0 034 107
+11 12 1 437 395 (15x)
→09/1995



ZKHS **302.350**
11 12 0 034 108
10/1995→
→09/1998



ZKHS **318.580**
11 12 0 034 108
+11 12 1 437 395 (15x)
10/1995→
→09/1998

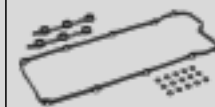

ZKHS **318.590**
11 12 9 070 990
+11 12 1 437 395 (15x)
09/1998→



ZKHS **326.560**
11 12 9 070 990
09/1998→

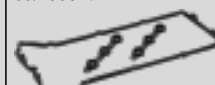

147.610
11 12 1 738 701
→09/1995















425.370
11 12 1 703 342
10/1995→
→09/1998



827.312
11 12 1 735 721
→09/1995
2x

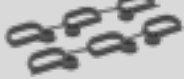

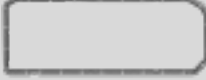
			<p>a) </p> <p>b) </p>	<p>K: </p> <p>N: </p>	
<p>VAS 424.820 FPM 403.730 11 34 2 245 151 FPM 24x</p>	<p>147.581 11 62 1 744 252 →09/1998 2x </p> <p>326.250 11 62 1 732 969 09/1998→ Euro 2 / Euro 3 (D3) 2x </p>	<p>AAS 366.500 11 61 1 436 631 09/1998→ </p> <p>147.590 11 61 1 740 069 2x →09/1998 </p>	<p>a) 424.510 11 13 9 065 875 </p> <p>b) 110.906 07 11 9 963 151 CU A 12x17x1,5</p>	<p>K:← 050.260 11 14 2 249 532 AS RD PTFE/ACM 48x65x10</p> <p>K:← 586.676 11 14 1 275 466 A/BS RD FPM 48x65x10</p> <p>K:→ 301.870 11 14 2 249 533 A/BS LD PTFE/FPM 90x110x12</p> <p>K:→ 702.994 11 14 1 706 999 A/BS LD FPM 90x110x12</p>	

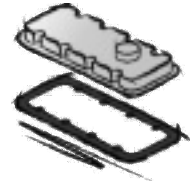
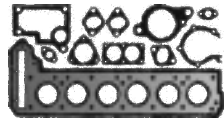
BMW**M52 B25 (256S3)**

6 Cyl. **2494 ccm**
Cyl. 84,0 Ø

323 i (E36)

05/1995 → 11/1999

323 i (E46)

10/1999 → 12/2000

323 ti (E36)

09/1997 → 08/2000

523 i (E39)

09/1995 → 08/2000

ES⊕ **147.600**

11 12 1 740 984

→09/1995

ES⊕ **444.440**

incl. 914.495

11 12 1 427 826

10/1995→

→09/1998

ES⊕ **445.470**

11 12 1 427 826

10/1995→

→09/1998

ES⊕ **366.560**

11 12 1 436 822

+11 62 1 732 969 (2x)

09/1998→



ES⊕ **905.590**

11 12 1 436 822

+11 62 1 732 969 (2x)

+11 12 7 501 304

09/1998→

CS* **424.901**

11 11 1 740 981

→09/1998

CS* **359.160**

11 11 1 432 478

09/1998→

893.812

11 12 1 726 617

1,75 mm $\frac{3}{16}$ 85 Ø

→09/1998

914.495

11 12 1 726 620

2,05 mm $\frac{3}{16}$ 85 Ø

→09/1998

361.473

11 12 7 501 304

0,70 mm $\frac{3}{16}$ 85 Ø

09/1998→

361.503

11 12 7 501 305

1,00 mm $\frac{3}{16}$ 85 Ø

09/1998→



ZKS **802.740**

11 12 1 721 938

M 10x1,5x95



ZKS **802.820**

11 12 1 740 065

M 10x1,5x110



425.390

11 12 1 748 872

10/1995→

2x











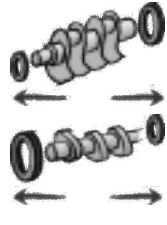

436.010

11 12 1 437 395

15x

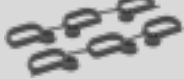

			<p>a) </p> <p>b) </p>	<p>K: </p> <p>N: </p>	
<p>VAS 424.820 FPM 403.730 11 34 2 245 151 FPM 24x</p>	<p>147.581 11 62 1 744 252 →09/1998 2x </p> <p>326.250 11 62 1 732 969 09/1998→ Euro 2 / Euro 3 (D3) 2x </p>	<p>AAS 366.500 11 61 1 436 631 09/1998→ </p> <p>147.590 11 61 1 740 069 2x →09/1998 </p>	<p>a) 424.510 11 13 9 065 875 </p> <p>b) 110.906 07 11 9 963 151 CU A 12x17x1,5</p>	<p>K:← 050.260 11 14 2 249 532 AS RD PTFE/ACM 48x65x10</p> <p>K:← 586.676 11 14 1 275 466 A/BS RD FPM 48x65x10</p> <p>K:→ 301.870 11 14 2 249 533 A/BS LD PTFE/FPM 90x110x12</p> <p>K:→ 702.994 11 14 1 706 999 A/BS LD FPM 90x110x12</p>	

BMW

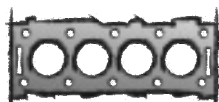
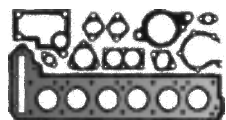

M52 B25 (256S4)

6 Cyl. **2494 ccm**
Cyl. 84,0 Ø

323 Ci (E46)

04/1999 → 09/2000

323 i (E46)

03/1998 → 12/2000

523 i (E39)

09/1995 → 08/2000

Z3 (E36)

09/1998 → 09/2000

ES⊕ **444.440**
incl. 914.495
11 12 1 427 826
→09/1998

ES⊕ **445.470**
11 12 1 427 826
→09/1998

ES⊕ **366.560**
11 12 1 436 822
+11 62 1 732 969 (2x)
09/1998→



ES⊕ **905.590**
11 12 1 436 822
+11 62 1 732 969 (2x)
+11 12 7 501 304
09/1998→

CS* **424.901**
11 11 1 740 981
→09/1998

CS* **359.160**
11 11 1 432 478
09/1998→

893.812

11 12 1 726 617
1,75 mm $\frac{3}{16}$ 85 Ø
→09/1998

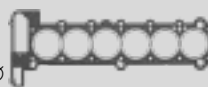

914.495

11 12 1 726 620
2,05 mm $\frac{3}{16}$ 85 Ø
→09/1998



361.473

11 12 7 501 304
0,70 mm $\frac{3}{16}$ 85 Ø
09/1998→



361.503

11 12 7 501 305
1,00 mm $\frac{3}{16}$ 85 Ø
09/1998→



ZKS 802.740

11 12 1 721 938
M 10x1,5x95



ZKS 802.820

11 12 1 740 065
M 10x1,5x110



ZKHS 302.350

11 12 0 034 108
→09/1998



ZKHS 318.580

11 12 0 034 108
+11 12 1 437 395 (15x)
→09/1998

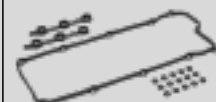

ZKHS 318.590

11 12 9 070 990
+11 12 1 437 395 (15x)
09/1998→



ZKHS 326.560

11 12 9 070 990
09/1998→

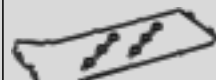

425.370

11 12 1 703 342
→09/1998



425.390











11 12 1 748 872
2x

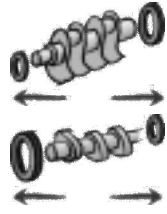

436.010

11 12 1 437 395
15x

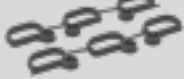

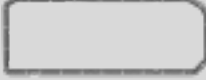
			<p>a) </p> <p>b) </p>	<p>K: </p> <p>N: </p>	
<p>VAS 424.820 FPM 403.730 11 34 2 245 151 FPM 24x</p>	<p>147.581 11 62 1 744 252 →09/1998 2x </p> <p>326.250 11 62 1 732 969 09/1998→ Euro 2 / Euro 3 (D3) 2x </p>	<p>AAS 366.500 11 61 1 436 631 09/1998→ </p> <p>147.590 11 61 1 740 069 2x →09/1998 </p>	<p>a) 424.510 11 13 9 065 875 </p> <p>b) 774.390 11 13 1 273 093 M 12x1,5x18</p> <p>b) 110.906 07 11 9 963 151 CU A 12x17x1,5</p> <p>b) 238.708 07 11 9 963 130 AL A 12x15,5x1,5</p>	<p>K:← 050.260 11 14 2 249 532 AS RD PTFE/ACM 48x65x10</p> <p>K:← 586.676 11 14 1 275 466 A/BS RD FPM 48x65x10</p> <p>K:→ 301.870 11 14 2 249 533 A/BS LD PTFE/FPM 90x110x12</p> <p>K:→ 702.994 11 14 1 706 999 A/BS LD FPM 90x110x12</p>	

BMW

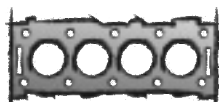
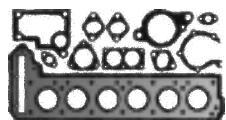

M54 B25 (256S3)/(256S5)

6 Cyl. 2494 ccm
Cyl. 84,0 Ø

325 Ci (E46)

09/2000 → 12/2006

325 i (E46)

09/2000 → 04/2005

325 ti (E46)

04/2001 → 12/2004

525 i (E39)

09/2000 → 05/2004

525 i (E60/61)

07/2003 → 12/2010

X3 25 i (E83)

01/2004 → 12/2006

Z3 (E36)

10/2000 → 08/2002

Z4 2.5 i (E85)

12/2002 → 12/2005

Z4 2.5 i (E86)

11/2006 → 04/2008

ES⊕ **366.530**
11 12 7 507 597
→09/2002



ES⊕ **903.340**
RHD
→09/2002



ES⊕ **905.600**
→09/2002

ES⊕ **382.800**
11 12 0 141 055
10/2002→



ES⊕ **903.350**
RHD
10/2002→



ES⊕ **905.610**
10/2002→

CS* **359.160**
11 11 1 432 478

361.473
11 12 7 501 304
0,70 mm $\frac{3}{4}$ 85 Ø



361.503
11 12 7 501 305
1,00 mm $\frac{3}{4}$ 85 Ø



ZKS **802.820**
11 12 1 740 065
M 10x1,5x110



ZKHS **318.590**
11 12 9 070 990
+11 12 1 437 395 (15x)
→09/2002



ZKHS **326.560**
11 12 9 070 990
→09/2002



ZKHS **318.600**
11 12 0 030 496
+11 12 1 437 395 (15x)
10/2002→



ZKHS **382.750**
11 12 0 030 496
10/2002→











425.390
11 12 1 748 872
→09/2002
2x

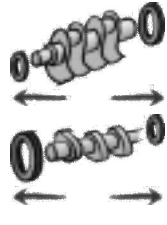

436.010
11 12 1 437 395
15x

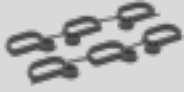
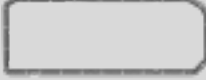

			<p>a) </p> <p>b) </p>	<p>K: </p> <p>N: </p>	
<p>VAS 424.820 FPM 403.730 11 34 2 245 151 FPM 24x</p>	<p>326.250 11 62 1 732 969 Euro 2 / Euro 3 (D3) 2x</p>  <p>738.340 RHD 11 62 7 522 585 2x</p> 	<p>AAS 366.500 11 61 1 436 631</p> 	<p>a) 424.510 11 13 9 065 875</p>  <p>b) 774.390 11 13 1 273 093 M 12x1,5x18</p> <p>b) 110.906 07 11 9 963 151 CU A 12x17x1,5</p> <p>b) 238.708 07 11 9 963 130 AL A 12x15,5x1,5</p>	<p>K:← 050.260 11 14 2 249 532 AS RD PTFE/ACM 48x65x10</p> <p>K:→ 301.870 11 14 2 249 533 A/BS LD PTFE/FPM 90x110x12</p> <p>K:→ 702.994 11 14 1 706 999 A/BS LD FPM 90x110x12</p>	

BMW

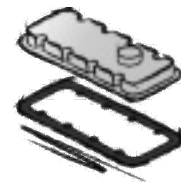
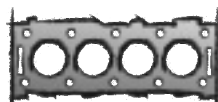
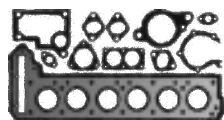

M51 D25 (256T1)

6 Cyl. 2497 ccm
Cyl. 80,0 Ø

325 td (E36)

09/1991 → 04/1999

525 td (E34)

09/1991 → 07/1996

525 td (E39)

01/1996 → 05/2004

525 tds (E34)

12/1991 → 07/1996

725 tds (E38)

04/1996 → 11/2001

ES⊕ **834.440**
11 12 2 244 328
→08/1992



ES⊕ **446.870**
11 12 9 065 445
09/1992→
→01/1996



ES⊕ **198.660**
11 12 9 070 622
01/1996→



CS* **445.400**
11 11 2 245 749
02/1994→



894.605
11 12 2 245 483
0,540 mm
→
0,760 mm

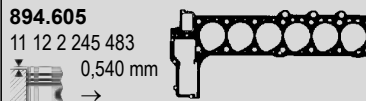

1,68 mm $\frac{1}{2}$ 81 Ø
2 ⊗
→01/1994

894.613

11 12 2 245 484
0,770 mm
→
0,990 mm



1,87 mm $\frac{1}{2}$ 81 Ø
3 ⊗
→01/1994

424.420

11 12 2 245 426
0,540 mm
→
0,760 mm



1,68 mm $\frac{1}{2}$ 81 Ø
2 ⊗
02/1994→

424.480

11 12 2 245 427
0,770 mm
→
0,990 mm



1,87 mm $\frac{1}{2}$ 81 Ø
3 ⊗
02/1994→

ZKS **802.801**
11 12 9 067 790
M 12x1,5x147



893.420
11 12 2 244 398
→01/1996



190.440

11 12 2 245 686
01/1996→

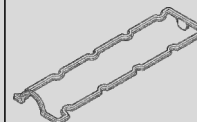

M57 D25 (256D1)/(256D2)

6 Cyl. 2497 ccm
Cyl. 80,0 Ø

525 d (E39)

02/2000 → 05/2004

525 d (E60/61)

03/2004 → 03/2010

ES⊕ **157.570**
11 12 2 248 895



CS* **301.400**
11 11 2 248 975

157.480
11 12 2 354 014
1,55 mm $\frac{1}{2}$
2 ▽



157.490
11 12 2 354 015
1,65 mm $\frac{1}{2}$
3 ▽



ZKS **802.801**
11 12 9 067 790
M 12x1,5x147





















ZKHS **157.680**
11 12 2 247 447



060.062









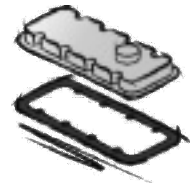
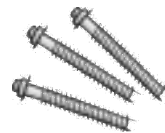
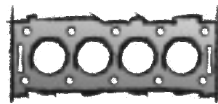
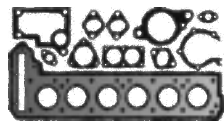





11 12 7 796 378



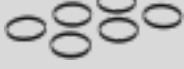



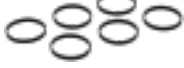



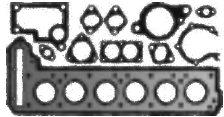
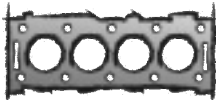

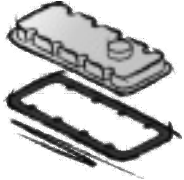















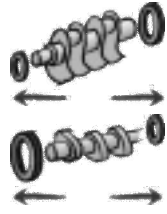

			<p>a) </p> <p>b) </p>	<p>K: </p> <p>N: </p>	
<p>VAS 825.050 11 34 9 059 172 FPM →08/1992</p> <p>VAS 424.780 11 34 9 064 457 09/1992→</p> <p>701.289 11 34 1 706 707 FPM →08/1992 12x</p> <p>403.730 11 34 2 245 151 FPM 09/1992→ 12x</p>	<p>833.274 11 62 2 243 782 →01/1996 4x</p>  <p>146.587 11 62 2 246 172 01/1996→</p>  <p>146.593 11 62 2 246 174 01/1996→ 4x</p> 	<p>821.012 11 61 2 244 391 →01/1996 6x</p>  <p>424.870 11 61 2 245 438 01/1996→ 6x</p> 	<p>a) 894.656 11 13 9 066 503</p>  <p>b) 455.740 11 13 7 535 106 +07 11 9 963 151 M 12x1,5x16</p> <p>b) 110.906 07 11 9 963 151 CU A 12x17x1,5</p>	<p>K:← 050.260 11 14 2 249 532 AS RD PTFE/ACM 48x65x10</p> <p>K:← 586.676 11 14 1 275 466 A/BS RD FPM 48x65x10</p> <p>K:→ 301.870 11 14 2 249 533 A/BS LD PTFE/FPM 90x110x12</p> <p>K:→ 702.994 11 14 1 706 999 A/BS LD FPM 90x110x12</p>	
<p>VAS 152.390 11 34 9 071 732 FPM</p> <p>157.560 11 34 2 247 171 FPM 24x</p>	<p>066.391 11 62 7 796 480 3x</p> 	<p>AAS 228.690 11 61 7 790 198 (6x) +11 61 2 246 945 (6x) +11 61 2 245 439 (1x)</p>  <p>074.990 11 61 7 790 198 6x</p> 	<p>a) 151.900 11 13 7 788 439</p>  <p>b) 455.740 11 13 7 535 106 +07 11 9 963 151 M 12x1,5x16</p> <p>b) 110.906 07 11 9 963 151 CU A 12x17x1,5</p>	<p>K:← 301.890 11 14 2 249 534 AW/BS RD PTFE/ACM 55x68x8</p> <p>K:→ 301.870 11 14 2 249 533 A/BS LD PTFE/FPM 90x110x12</p>	<p>TLS 703.871</p> 

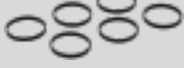
BMW



			<p>a) </p> <p>b) </p>	<p>K: </p> <p>N: </p>	
<p>VAS 364.500 11 34 0 034 068 FPM 03/2006→ E</p> <p>VAS 367.480 11 34 0 032 582 FPM →03/2006 A E</p> <p>VAS 660.360 11 34 0 035 853 FPM 03/2006→ A</p>	<p>504.380 18 40 7 530 606 6x</p> 	<p>AAS 537.890 11 61 7 547 242</p> 	<p>a) 298.130 11 13 7 600 482 5 F10/11</p>  <p>a) 545.840 11 13 7 548 031</p>  <p>b) 455.740 11 13 7 535 106 +07 11 9 963 151 M 12x1,5x16</p> <p>b) 110.906 07 11 9 963 151 CU A 12x17x1,5</p>	<p>K:← 257.400 11 11 7 511 395 ASW RD PTFE/ACM 65x79x20 →02/2011</p> <p>K:← 902.860 11 11 8 618 864 ASW RD PTFE/ACM 65x79x10 02/2011→</p> <p>K:→ 751.610 11 11 7 587 168 AW OF LD FPM 90x110x8</p>	
<p>VAS 364.500 11 34 0 034 068 FPM 03/2006→ E</p> <p>VAS 367.480 11 34 0 032 582 FPM →03/2006 A E</p> <p>VAS 660.360 11 34 0 035 853 FPM 03/2006→ A</p>	<p>504.380 18 40 7 530 606 6x</p> 	<p>AAS 537.890 11 61 7 547 242</p> 	<p>a) 545.840 11 13 7 548 031</p>  <p>b) 455.740 11 13 7 535 106 +07 11 9 963 151 M 12x1,5x16</p> <p>b) 110.906 07 11 9 963 151 CU A 12x17x1,5</p>	<p>K:← 257.400 11 11 7 511 395 ASW RD PTFE/ACM 65x79x20 →02/2011</p> <p>K:← 902.860 11 11 8 618 864 ASW RD PTFE/ACM 65x79x10 02/2011→</p> <p>K:→ 751.610 11 11 7 587 168 AW OF LD FPM 90x110x8</p>	

BMW  Das Original				
N53 B25 A 6 Cyl. 2497 ccm Cyl. 82,0 Ø 523 i (E60/61) 01/2007 → 12/2010	ES⊕ 740.280 11 12 7 561 438  CS* 902.230 11 11 7 548 101	512.270 11 12 7 555 755 1,20 mm $\frac{\pm}{\text{mm}}$ 83 Ø  512.290 11 12 7 555 756 1,50 mm $\frac{\pm}{\text{mm}}$ 83 Ø 	ZKS 270.190 11 12 7 548 799 M 10x1,5x125 	740.290 11 12 7 544 368 
M20 B27 (276EA)/(276EB)/ (276KA)/(276KB) 6 Cyl. 2693 ccm Cyl. 84,0 Ø 325 e 2.7 (E30) 10/1983 → 12/1988 525 e 2.7 (E28) 09/1981 → 12/1987 528 e 2.7 (E28) 03/1983 → 12/1987	ES⊕ 820.938 11 12 9 059 249 →12/1986 ES⊕ 444.450 incl. 567.818 01/1987→ ES⊕ 818.747 11 12 9 059 240 01/1987→ CS* 892.106 11 11 9 063 134	694.011 11 12 1 722 737 1,75 mm $\frac{\pm}{\text{mm}}$ 85 Ø  567.818 11 12 1 722 738 2,05 mm $\frac{\pm}{\text{mm}}$ 85 Ø 	ZKS 820.229 11 12 1 726 478 M 10x1,5x150 	774.693 11 12 1 730 271 

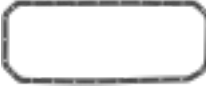
			<p>a) </p> <p>b) </p>	<p>K: </p> <p>N: </p>	
<p>VAS 364.500 11 34 0 034 068 FPM E</p> <p>VAS 660.360 11 34 0 035 853 FPM A</p>	<p>504.380 18 40 7 530 606 6x</p> 	<p>AAS 537.890 11 61 7 547 242</p> 	<p>a) 545.840 11 13 7 548 031</p>  <p>b) 455.740 11 13 7 535 106 +07 11 9 963 151 M 12x1,5x16</p> <p>b) 110.906 07 11 9 963 151 CU A 12x17x1,5</p>	<p>K:← 257.400 11 11 7 511 395 ASW RD PTFE/ACM 65x79x20</p> <p>K:→ 751.610 11 11 7 587 168 AW OF LD FPM 90x110x8</p>	
<p>VAS 825.050 11 34 9 059 172 FPM</p> <p>701.289 11 34 1 706 707 FPM 12x</p>	<p>888.516 11 62 1 723 877 →12/1986 6x</p>  <p>495.900 11 62 1 728 489 01/1987→ 2x</p> 	<p>776.602 11 61 1 730 787 →12/1986 4x</p>  <p>810.851 11 61 1 730 743 →12/1986</p>  <p>774.553 11 61 1 726 010 01/1987→ 4x</p>  <p>774.561 11 61 1 726 012 01/1987→</p> 	<p>a) 888.346 11 13 1 730 234</p>  <p>b) 774.390 11 13 1 273 093 M 12x1,5x18</p> <p>b) 238.708 07 11 9 963 130 AL A 12x15,5x1,5</p>	<p>K:← 586.676 11 14 1 275 466 A/BS RD FPM 48x65x10</p> <p>K:→ 301.870 11 14 2 249 533 A/BS LD PTFE/FPM 90x110x12</p> <p>K:→ 702.994 11 14 1 706 999 A/BS LD FPM 90x110x12</p> <p>N:← 586.668 11 12 1 285 609 ASW WD FPM 38x50x7</p>	

BMW

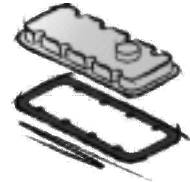
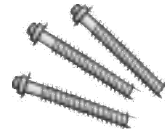
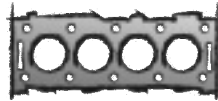
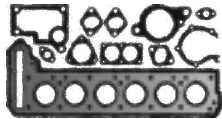

M52 B28 (286S1)/(286S2)

6 Cyl. 2793 ccm
Cyl. 84,0 Ø

328 Ci (E46)

12/1998 → 05/2000

328 i (E36)

01/1995 → 11/1999

328 i (E46)

02/1998 → 12/2000

528 i (E39)

09/1995 → 08/2000

728 i, iL (E38)

08/1995 → 11/2001

728 i X (E38)

11/1995 → 09/2001

Z3 (E36)

01/1996 → 07/2000

ES⊕ **147.600**

11 12 1 740 984

→09/1995

ES⊕ **444.440**

incl. 914.495

11 12 1 427 826

09/1995→

→09/1998

ES⊕ **445.470**

11 12 1 427 826

09/1995→

→09/1998

ES⊕ **366.560**

11 12 1 436 822

+11 62 1 732 969 (2x)

09/1998→

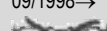

ES⊕ **905.590**

11 12 1 436 822

+11 62 1 732 969 (2x)

+11 12 7 501 304

09/1998→

CS* **424.901**

11 11 1 740 981

→09/1998

CS* **359.160**

11 11 1 432 478

09/1998→

893.812

11 12 1 726 617

1,75 mm $\frac{3}{16}$ 85 Ø

→09/1998

914.495

11 12 1 726 620

2,05 mm $\frac{3}{16}$ 85 Ø

→09/1998

361.473

11 12 7 501 304

0,70 mm $\frac{3}{16}$ 85 Ø

09/1998→

361.503

11 12 7 501 305

1,00 mm $\frac{3}{16}$ 85 Ø

09/1998→

ZKS **802.740**

11 12 1 721 938

M 10x1,5x95



ZKS **802.820**

11 12 1 740 065

M 10x1,5x110



ZKHS **302.340**

11 12 0 034 107

→09/1995



ZKHS **318.550**

11 12 0 034 107

+11 12 1 437 395 (15x)

→09/1995



ZKHS **302.350**

11 12 0 034 108

09/1995→

→09/1998

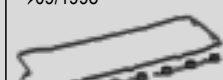

ZKHS **318.580**

11 12 0 034 108

+11 12 1 437 395 (15x)

09/1995→

→09/1998

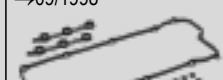

ZKHS **318.590**

11 12 9 070 990

+11 12 1 437 395 (15x)

09/1998→

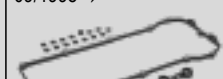

ZKHS **326.560**

11 12 9 070 990

09/1998→

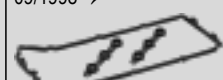

147.610

11 12 1 738 701

01/1995→

→09/1995

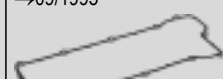

425.370

11 12 1 703 342

09/1995→

→09/1998

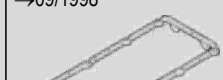







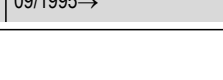

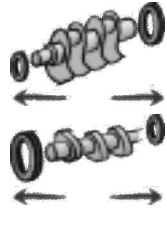

425.390

11 12 1 748 872

09/1995→

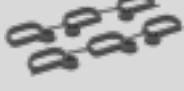

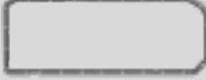
			<p>a) </p> <p>b) </p>	<p>K: </p> <p>N: </p>	
<p>VAS 424.820 FPM 403.730 11 34 2 245 151 FPM 24x</p>	<p>147.581 11 62 1 744 252 →09/1998 2x </p> <p>326.250 11 62 1 732 969 09/1998→ Euro 2 / Euro 3 (D3) 2x </p>	<p>AAS 366.500 11 61 1 436 631 09/1998→ </p> <p>147.590 11 61 1 740 069 2x →09/1998 </p>	<p>a) 424.510 11 13 9 065 875 </p> <p>b) 774.390 11 13 1 273 093 M 12x1,5x18</p> <p>b) 110.906 07 11 9 963 151 CU A 12x17x1,5</p> <p>b) 238.708 07 11 9 963 130 AL A 12x15,5x1,5</p>	<p>K:← 050.260 11 14 2 249 532 AS RD PTFE/ACM 48x65x10</p> <p>K:← 586.676 11 14 1 275 466 A/BS RD FPM 48x65x10</p> <p>K:→ 301.870 11 14 2 249 533 A/BS LD PTFE/FPM 90x110x12</p> <p>K:→ 702.994 11 14 1 706 999 A/BS LD FPM 90x110x12</p>	

BMW

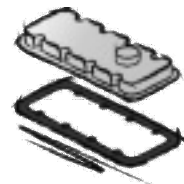
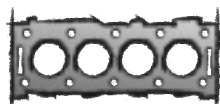
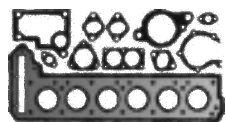

M52 B28 (286S1)/(286S2)

6 Cyl. 2793 ccm
Cyl. 84,0 Ø

328 Ci (E46)
12/1998 → 05/2000

328 i (E36)
01/1995 → 11/1999

328 i (E46)
02/1998 → 12/2000

528 i (E39)
09/1995 → 08/2000

728 i, iL (E38)
08/1995 → 11/2001

728 i X (E38)
11/1995 → 09/2001

Z3 (E36)
01/1996 → 07/2000

ES⊕ **147.600**
11 12 1 740 984
→09/1995

ES⊕ **444.440**
incl. 914.495
11 12 1 427 826
09/1995→
→09/1998

ES⊕ **445.470**
11 12 1 427 826
09/1995→
→09/1998

ES⊕ **366.560**
11 12 1 436 822
+11 62 1 732 969 (2x)
09/1998→

ES⊕ **905.590**
11 12 1 436 822
+11 62 1 732 969 (2x)
+11 12 7 501 304
09/1998→

CS* **424.901**
11 11 1 740 981
→09/1998

CS* **359.160**
11 11 1 432 478
09/1998→



893.812
11 12 1 726 617
1,75 mm $\frac{\pm}{\pm}$ 85 Ø

914.495
11 12 1 726 620
2,05 mm $\frac{\pm}{\pm}$ 85 Ø

361.473
11 12 7 501 304
0,70 mm $\frac{\pm}{\pm}$ 85 Ø

361.503
11 12 7 501 305
1,00 mm $\frac{\pm}{\pm}$ 85 Ø

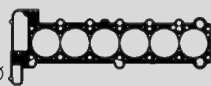
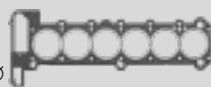

ZKS **802.740**
11 12 1 721 938
M 10x1,5x95



ZKS **802.820**
11 12 1 740 065
M 10x1,5x110



2x
 436.010
11 12 1 437 395
15x



M57 D30 (306D1)

6 Cyl. 2926 ccm
Cyl. 84,0 Ø

330 d (E46)
10/1999 → 02/2005

530 d (E39)
08/1998 → 05/2004

730 d (E38)
08/1998 → 11/2001

X5 3.0 d (E53)
04/2001 → 09/2003

ES⊕ **157.570**
11 12 2 248 895

CS* **301.400**
11 11 2 248 975



157.410
11 12 2 248 982
0,770 mm
→
0,920 mm

1,45 mm $\frac{\pm}{\pm}$
1 ∇

157.420
11 12 2 248 983
0,930 mm
→
1,030 mm

1,55 mm $\frac{\pm}{\pm}$
2 ∇

157.430
11 12 2 248 984
1,040 mm
→
1,180 mm

1,65 mm $\frac{\pm}{\pm}$
3 ∇

157.440
11 12 2 788 642
1,190 mm
→
1,80 mm $\frac{\pm}{\pm}$

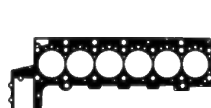
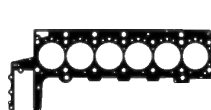
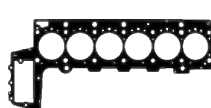
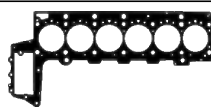

ZKS **802.801**
11 12 9 067 790
M 12x1,5x147

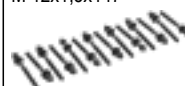







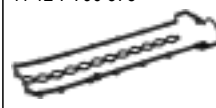









ZKHS **157.680**
11 12 2 247 447

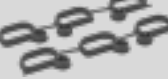

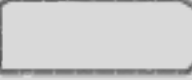







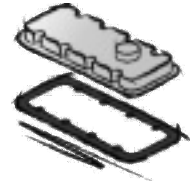
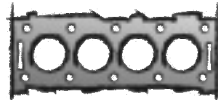
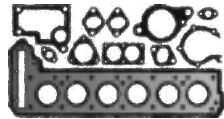





060.062
11 12 7 796 378

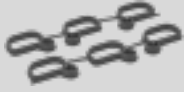
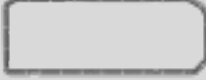

			<p>a) </p> <p>b) </p>	<p>K: </p> <p>N: </p>	
<p>VAS 424.820 FPM 403.730 11 34 2 245 151 FPM 24x</p>	<p>147.581 11 62 1 744 252 →09/1998 2x </p> <p>326.250 11 62 1 732 969 09/1998→ Euro 2 / Euro 3 (D3) 2x </p>	<p>AAS 366.500 11 61 1 436 631 09/1998→ </p> <p>147.590 11 61 1 740 069 2x →09/1998 </p>	<p>a) 424.510 11 13 9 065 875 </p> <p>b) 774.390 11 13 1 273 093 M 12x1,5x18</p> <p>b) 110.906 07 11 9 963 151 CU A 12x17x1,5</p> <p>b) 238.708 07 11 9 963 130 AL A 12x15,5x1,5</p>	<p>K:← 050.260 11 14 2 249 532 AS RD PTFE/ACM 48x65x10</p> <p>K:← 586.676 11 14 1 275 466 A/BS RD FPM 48x65x10</p> <p>K:→ 301.870 11 14 2 249 533 A/BS LD PTFE/FPM 90x110x12</p> <p>K:→ 702.994 11 14 1 706 999 A/BS LD FPM 90x110x12</p>	
<p>VAS 152.390 11 34 9 071 732 FPM</p>	<p>066.391 11 62 7 796 480 3x </p>	<p>AAS 228.690 11 61 7 790 198 (6x) +11 61 2 246 945 (6x) +11 61 2 245 439 (1x) </p> <p>074.990 11 61 7 790 198 6x </p>	<p>a) 151.900 11 13 7 788 439 </p> <p>b) 455.740 11 13 7 535 106 +07 11 9 963 151 M 12x1,5x16</p> <p>b) 110.906 07 11 9 963 151 CU A 12x17x1,5</p>	<p>K:← 301.890 11 14 2 249 534 AW/BS RD PTFE/ACM 55x68x8</p> <p>K:→ 301.870 11 14 2 249 533 A/BS LD PTFE/FPM 90x110x12</p>	

BMW



			<p>a) </p> <p>b) </p>	<p>K: </p> <p>N: </p>	
<p>VAS 424.820 FPM 403.730 11 34 2 245 151 FPM 24x</p>	<p>326.250 11 62 1 732 969 Euro 2 / Euro 3 (D3) 2x </p> <p>738.340 RHD 11 62 7 522 585 2x </p>	<p>AAS 366.500 11 61 1 436 631 </p>	<p>a) 424.510 11 13 9 065 875 </p> <p>b) 774.390 11 13 1 273 093 M 12x1,5x18</p> <p>b) 110.906 07 11 9 963 151 CU A 12x17x1,5</p> <p>b) 238.708 07 11 9 963 130 AL A 12x15,5x1,5</p>	<p>K:← 050.260 11 14 2 249 532 AS RD PTFE/ACM 48x65x10</p> <p>K:→ 301.870 11 14 2 249 533 A/BS LD PTFE/FPM 90x110x12</p> <p>K:→ 702.994 11 14 1 706 999 A/BS LD FPM 90x110x12</p>	
<p>VAS 364.500 11 34 0 034 068 FPM E VAS 660.360 11 34 0 035 853 FPM A</p>	<p>727.830 11 62 7 558 906 6x </p>	<p>AAS 537.890 11 61 7 547 242 </p>	<p>a) 545.840 11 13 7 548 031 </p> <p>b) 455.740 11 13 7 535 106 +07 11 9 963 151 M 12x1,5x16</p> <p>b) 110.906 07 11 9 963 151 CU A 12x17x1,5</p>	<p>K:← 257.400 11 11 7 511 395 ASW RD PTFE/ACM 65x79x20 →02/2011</p> <p>K:← 902.860 11 11 8 618 864 ASW RD PTFE/ACM 65x79x10 02/2011→</p> <p>K:→ 301.870 11 14 2 249 533 A/BS LD PTFE/FPM 90x110x12</p> <p>K:→ 751.610 11 11 7 587 168 AW OF LD FPM 90x110x8</p>	<p>TLS 298.900 </p>

BMW

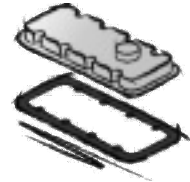
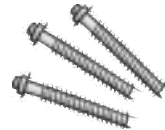
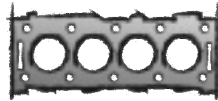
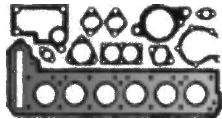

N55 B30 A

6 Cyl. 2979 ccm
Cyl. 84,0 Ø

- 135 i (E82/88)**
10/2007 → 12/2013
- 335 i (E90/91/92/93)**
03/2006 → 12/2013
- 335 i (F30/31/34/35)**
11/2011 → 06/2016
- 435 i (F32/33/36/82/83)**
07/2013 → 02/2016
- 535 i (F07/10/11/18)**
01/2009 → 02/2017
- 640 i (F06/12/13)**
07/2011 → 10/2018
- 740 i (F01-F04)**
07/2012 → 12/2015
- ActiveHybrid (F01-F04)**
08/2012 → 06/2015
- ActiveHybrid (F10/11/18)**
12/2011 → 10/2016
- ActiveHybrid (F30/31/35)**
07/2012 → 06/2015
- M 135 i (F20/21)**
12/2011 →
- M2 (F22/87)**
11/2015 → 06/2018
- M 235 i (F22/23)**
10/2013 →
- X3 35 i (F25)**
09/2010 → 08/2017
- X4 35 i (F26)**
04/2014 → 03/2018
- X4 M 40 i (F26)**
12/2015 → 03/2018
- X5 35 i (E70)**
04/2010 → 07/2013
- X5 35 i (F15/85)**
08/2013 → 07/2018
- X5 40 i (E70)**
01/2012 → 06/2013
- X6 35 i (E71/72)**
01/2008 → 07/2014
- X6 35 i (F16/86)**
08/2014 → 07/2019

ES⊕ **595.090**



CS* **648.530**

186.030

11 12 7 599 212
1,20 mm $\frac{1}{2}$



797.820

11 12 7 599 213
1,50 mm $\frac{1}{2}$

ZKS **459.450**
11 12 2 165 470



ZKHS **299.770**
11 12 7 587 804



503.791

11 12 7 573 439
→01/2011
3x



655.581

11 12 7 589 830
01/2011→
3x



S55 B30 A

6 Cyl. 2979 ccm
Cyl. 84,0 Ø

- M2 (F22/87)**
06/2018 →
- M3 (F80)**
03/2014 → 10/2018
- M4 (F32/33/82/83)**
03/2014 →
- M4 CS (F32/82)**
07/2017 → 06/2019
- M4 GTS (F32/82)**
03/2016 → 02/2017

ES⊕ **702.620**















CS* **794.720**





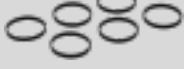





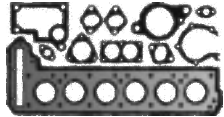
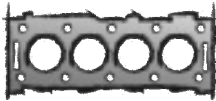

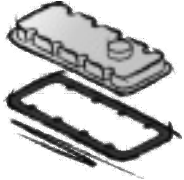
ZKS **702.230**
11 12 7 853 937
M12x173 M9x30/70

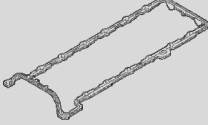











655.581

11 12 7 589 830
3x

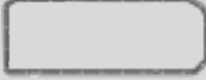

			<p>a) </p> <p>b) </p>	<p>K: </p> <p>N: </p>	
<p>VAS 364.500 11 34 0 034 068 FPM E</p> <p>VAS 660.360 11 34 0 035 853 FPM A</p>	<p>738.190 11 65 7 593 303 6x</p> 	<p>AAS 537.890 11 61 7 547 242</p> 	<p>a) 298.130 11 13 7 600 482</p>  <p>b) 455.740 11 13 7 535 106 +07 11 9 963 151 M 12x1,5x16</p> <p>b) 110.906 07 11 9 963 151 CU A 12x17x1,5</p>	<p>K:← 257.400 11 11 7 511 395 ASW RD PTFE/ACM 65x79x20 →02/2011</p> <p>K:← 902.860 11 11 8 618 864 ASW RD PTFE/ACM 65x79x10 02/2011→</p> <p>K:→ 751.610 11 11 7 587 168 AW OF LD FPM 90x110x8</p>	<p>TLS 648.550</p> 
<p>VAS 364.500 11 34 0 034 068 FPM E</p> <p>VAS 660.360 11 34 0 035 853 FPM A</p>	<p>033.891 11 65 7 847 039 2x</p> 		<p>a) 298.130 11 13 7 600 482</p>  <p>b) 110.507 07 11 9 963 132 CU A 12x16x1</p>	<p>K:← 902.860 11 11 8 618 864 ASW RD PTFE/ACM 65x79x10</p> <p>K:→ 751.610 11 11 7 587 168 AW OF LD FPM 90x110x8</p>	

<p>BMW</p> 				
<p>S50 B30 (306S1) 6 Cyl. 2990 ccm Cyl. 86,0 Ø</p> <p>M3 3.0 (E36) 11/1992 → 07/1995</p>	<p>ES⊕ 894.699 11 12 1 402 384</p> <p>CS* 257.360 11 11 1 402 381</p>	<p>889.194 11 12 1 405 748 1,74 mm \pm</p> 		<p>894.738 11 12 1 404 358</p>  <p>894.729 11 12 1 317 386</p> 
<p>S50 B30 (306S2) 6 Cyl. 2990 ccm Cyl. 86,0 Ø</p> <p>M3 3.0 (E36) 03/1994 → 12/1995</p>	<p>ES⊕ 293.810 USA 11 12 9 067 421</p> <p>CS* 424.770 11 11 9 064 460</p>	<p>914.033 USA 11 12 1 405 106 1,74 mm \pm</p> 	<p>ZKS 802.740 11 12 1 721 938 M 10x1,5x95</p> 	<p>ZKHS 302.340 11 12 0 034 107</p>  <p>ZKHS 318.550 11 12 0 034 107 +11 12 1 437 395 (15x)</p>  <p>147.610 11 12 1 738 701</p>  <p>827.312 11 12 1 735 721 2x</p>  <p>436.010 11 12 1 437 395 15x</p> 

			<p>a) </p> <p>b) </p>	<p>K: </p> <p>N: </p>	
<p>VAS 424.820 FPM 2x</p> <p>403.730 11 34 2 245 151 FPM 24x</p>	<p>833.169 11 62 1 317 631 3x</p> 		<p>a) 424.510 11 13 9 065 875</p>  <p>b) 774.390 11 13 1 273 093 M 12x1,5x18</p> <p>b) 238.708 07 11 9 963 130 AL A 12x15,5x1,5</p>	<p>K:← 586.676 11 14 1 275 466 A/BS RD FPM 48x65x10</p> <p>K:→ 301.870 11 14 2 249 533 A/BS LD PTFE/FPM 90x110x12</p> <p>K:→ 702.994 11 14 1 706 999 A/BS LD FPM 90x110x12</p>	
<p>VAS 424.820 FPM 2x</p> <p>403.730 11 34 2 245 151 FPM 24x</p>	<p>821.020 11 62 1 728 983 3x</p> 	<p>888.605 11 61 1 717 259 6x</p> 	<p>a) 424.510 11 13 9 065 875</p>  <p>b) 774.390 11 13 1 273 093 M 12x1,5x18</p> <p>b) 238.708 07 11 9 963 130 AL A 12x15,5x1,5</p>	<p>K:← 586.676 11 14 1 275 466 A/BS RD FPM 48x65x10</p> <p>K:→ 301.870 11 14 2 249 533 A/BS LD PTFE/FPM 90x110x12</p> <p>K:→ 702.994 11 14 1 706 999 A/BS LD FPM 90x110x12</p>	

BMW

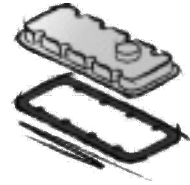
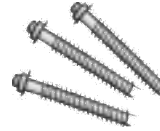
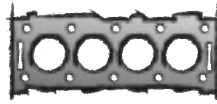

B57 D30 A

6 Cyl. **2993 ccm**
Cyl. 84,0 Ø

330 d (G20/21)

03/2019 →

530 d (G30/31)

09/2016 →

540 d (G30/31)

07/2017 → 06/2020

630 d (G32)

06/2017 → 06/2020

730 d (G11/12)

07/2015 → 06/2020

X3 30 d (G01)

08/2017 →

X4 30 d (G02)

04/2018 → 06/2020

X5 30 d (G05)

08/2018 →

X6 30 d (G06)

08/2019 → 07/2020

X7 30 d (G07)

03/2019 →

ES⊕ **820.750**



CS* **565.620**

283.561

11 12 8 571 134
1,45 mm $\frac{+}{-}$ 85 Ø
1 ⊗

283.571

11 12 8 571 135
1,55 mm $\frac{+}{-}$ 85 Ø
2 ⊗



283.581

11 12 8 571 136
1,65 mm $\frac{+}{-}$ 85 Ø
3 ⊗











ZKS **233.380**

11 12 8 513 130
M 12x1,5x200

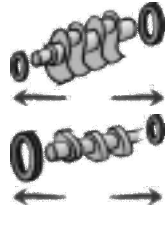

ZKHS **811.530**

11 12 8 590 172

			<p>a) </p> <p>b) </p>	<p>K: </p> <p>N: </p>	
<p>VAS 584.820 11 34 7 812 926</p>	<p>503.721 11 62 7 811 221 3x</p> 	<p>546.900 11 61 8 579 879 6x</p> 	<p>a) 030.793 Dirko HT</p> <p>b) 110.507 07 11 9 963 132 CU A 12x16x1</p>	<p>K:← 584.160 11 11 7 802 665 AW/BS OF RD FPM 55x68x8</p> <p>K:→ 492.060 11 14 7 797 490 AW/BS OF LD FPM 90x104x9</p>	

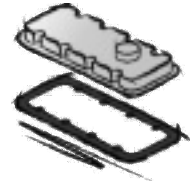
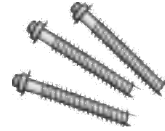
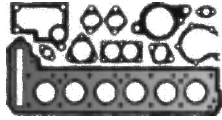
BMW**B57 D30 B**

6 Cyl. 2993 ccm
Cyl. 84,0 Ø

330 d (G20/21)

11/2020 →

430 d (G22/23)

03/2021 →

530 d (G30/31)

07/2020 →

540 d (G30/31)

07/2017 →

630 d (G32)

07/2020 →

640 d (G32)

11/2017 →

730 d (G11/12)

07/2020 →

740 d (G11/12)

11/2015 →

840 d (G14/15/16)

07/2018 →

M 340 d (G20/21/80)

04/2020 →

M 340 d (G20/21)

04/2020 →

M 440 d (G22/23)

03/2021 →

X3 30 d (G01)

07/2020 →

X3 M 40 d (G01)

08/2018 →

X4 30 d (G02)

07/2020 →

X4 M 40 d (G02)

04/2018 →

X5 30 d (G05)

08/2020 →

X5 40 d (G05)

05/2020 →

X6 30 d (G06)

08/2020 →

X6 40 d (G06)

05/2020 →

X7 40 d (G07)

03/2019 →

ES⊕ **820.850**CS* **565.620****383.890**

11 12 5 589 105

1,45 mm $\frac{1}{16}$ 85 Ø

1 ⊗

383.900

11 12 5 589 106

1,55 mm $\frac{1}{16}$ 85 Ø

2 ⊗

383.910

11 12 8 589 107

1,65 mm $\frac{1}{16}$ 85 Ø

3 ⊗

**ZKS 233.380**

11 12 8 513 130

M 12x1,5x200

**ZKHS 811.530**

11 12 8 590 172

B57 D30 C

6 Cyl. 2993 ccm
Cyl. 84,0 Ø

750 d (G11/12)

07/2016 →

M 550 d (G30/31)

06/2017 →

X5 M 50 d (F05)

08/2018 →

X6 M50 d (G06)

08/2019 →

X7 M 50 d (G07)

03/2019 →

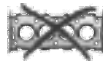
ES⊕ **820.860**CS* **565.620****473.800**

11 12 8 593 207

1,45 mm $\frac{1}{16}$ 85 Ø

1 ⊗

473.810

11 12 8 593 208

1,55 mm $\frac{1}{16}$ 85 Ø

2 ⊗

473.820

11 12 8 593 209

1,65 mm $\frac{1}{16}$ 85 Ø

3 ⊗

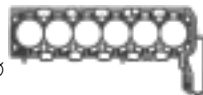











**ZKS 469.830**

11 12 8 570 942

M 12x1,5x179

**ZKHS 811.530**

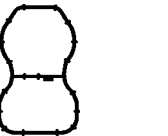
11 12 8 590 172

			<p>a) </p> <p>b) </p>	<p>K: </p> <p>N: </p>	
<p>VAS 584.820 11 34 7 812 926</p>	<p>589.841 11 62 8 594 638 3x</p> 	<p>546.900 11 61 8 579 879 6x</p> 	<p>a) 030.793 Dirko HT</p> <p>b) 110.507 07 11 9 963 132 CU A 12x16x1</p>	<p>K:← 584.160 11 11 7 802 665 AW/BS OF RD FPM 55x68x8</p> <p>K:→ 492.060 11 14 7 797 490 AW/BS OF LD FPM 90x104x9</p>	
<p>VAS 584.820 11 34 7 812 926</p>	<p>388.724 11 62 8 579 891 3x</p> 	<p>584.600 11 61 7 807 480 6x</p> 	<p>a) 380.271 11 13 8 575 780</p>  <p>b) 110.507 07 11 9 963 132 CU A 12x16x1</p>	<p>K:← 584.160 11 11 7 802 665 AW/BS OF RD FPM 55x68x8</p> <p>K:→ 492.060 11 14 7 797 490 AW/BS OF LD FPM 90x104x9</p>	

BMW

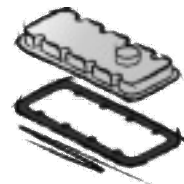
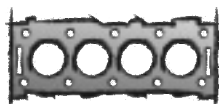
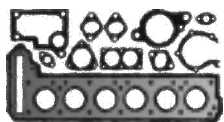

M57 D30 (306D2)

6 Cyl. 2993 ccm
Cyl. 84,0 Ø

330 Cd (E46)

03/2003 → 12/2007

330 d (E46)

08/2002 → 05/2005

530 d (E60/61)

09/2002 → 05/2010

730 d (E65/E66)

06/2002 → 08/2008

X3 30 d (E83)

01/2004 → 08/2005

X5 3.0 d (E53)

10/2003 → 09/2006

ES⊕ **151.960**
11 12 0 150 670



CS* **152.060**
11 11 7 790 458

428.440

11 12 7 788 587

→ 0,720 mm

→ 0,830 mm

1,45 mm $\frac{+}{-}$ 84,5 Ø

1 ▽

428.450

11 12 7 788 588

→ 0,840 mm

→ 0,930 mm

1,55 mm $\frac{+}{-}$ 84,5 Ø

2 ▽

428.460

11 12 7 788 589

→ 0,940 mm

→ 1,040 mm

1,65 mm $\frac{+}{-}$ 84,5 Ø

3 ▽

ZKS 802.801

11 12 9 067 790

M 12x1,5x147



ZKHS 157.680









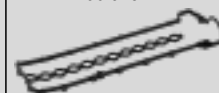



11 12 2 247 447



060.062

11 12 7 796 378

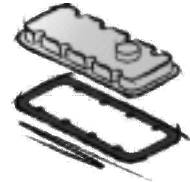
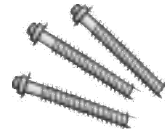
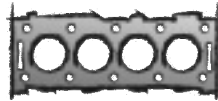
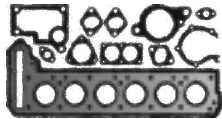

			<p>a) </p> <p>b) </p>	<p>K: </p> <p>N: </p>	
<p>VAS 152.390 11 34 9 071 732 FPM</p> <p>157.560 11 34 2 247 171 FPM 24x</p>	<p>066.391 11 62 7 796 480 3x</p> 	<p>AAS 228.690 11 61 7 790 198 (6x) +11 61 2 246 945 (6x) +11 61 2 245 439 (1x)</p>  <p>074.990 11 61 7 790 198 6x</p> 	<p>a) 151.900 11 13 7 788 439</p>  <p>b) 455.740 11 13 7 535 106 +07 11 9 963 151 M 12x1,5x16</p> <p>b) 110.906 07 11 9 963 151 CU A 12x17x1,5</p>	<p>K:← 301.890 11 14 2 249 534 AW/BS RD PTFE/ACM 55x68x8</p> <p>K:→ 073.910 11 14 7 787 262 IWD LD PTFE/FPM 90</p>	<p>TLS 703.871</p> 

BMW**M57 D30 (306D3)**

6 Cyl. **2993 ccm**
Cyl. 84,0 Ø

325 d (E90/91/92/93)

09/2006 → 06/2012

330 d (E90/91/92/93)

12/2004 → 12/2013

525 d (E60/61)

11/2006 → 05/2010

530 d (E60/61)

09/2002 → 05/2010

730 d (E65/E66)

09/2003 → 08/2008

730 Ld (E65/E66)

07/2005 → 08/2008

X3 30 d (E83)

09/2005 → 08/2010

X5 30 d (E70)

12/2006 → 07/2013

X6 30 d (E71/72)

04/2008 → 03/2010

ES⊕ **263.620**
11 12 7 798 533



CS* **272.110**

11 11 7 798 531
→02/2006

CS* **428.690**

11 11 0 421 208
02/2006→

058.051

11 12 7 794 067



0,770 mm

→

0,920 mm

1,47 mm $\frac{+}{-}$

1 ⊗

→02/2006

058.141

11 12 7 794 068

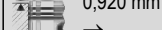

0,920 mm

→

1,030 mm

1,57 mm $\frac{+}{-}$

2 ⊗

→02/2006

058.191

11 12 7 794 069



1,030 mm

→

1,180 mm

1,67 mm $\frac{+}{-}$

3 ⊗

→02/2006

058.221 ●

11 12 7 794 857



1,180 mm

→

1,77 mm $\frac{+}{-}$

→02/2006

058.053

11 12 7 801 698

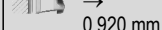

0,770 mm

→

0,920 mm

1,47 mm $\frac{+}{-}$

1 ⊗

02/2006→

058.143

11 12 7 801 699



0,920 mm

→

1,030 mm

1,57 mm $\frac{+}{-}$

2 ⊗

02/2006→

058.193

11 12 7 801 700

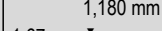

1,030 mm

→

1,180 mm

1,67 mm $\frac{+}{-}$

3 ⊗

02/2006→

058.223

11 12 7 801 701

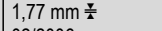

1,180 mm

→

1,77 mm $\frac{+}{-}$

02/2006→

ZKS 234.640

11 12 7 798 532

M 12x1,5x217















**ZKHS 157.680**

11 12 2 247 447

**060.062**

11 12 7 796 378

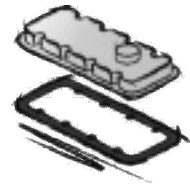
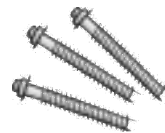
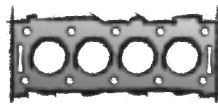
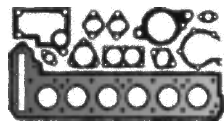

			<p>a) </p> <p>b) </p>	<p>K: </p> <p>N: </p>	
<p>VAS 152.390 11 34 9 071 732 FPM</p> <p>157.560 11 34 2 247 171 FPM 24x</p>	<p>171.480 11 62 7 798 177 3x</p> 	<p>AAS 228.690 11 61 7 790 198 (6x) +11 61 2 246 945 (6x) +11 61 2 245 439 (1x)</p>  <p>074.990 11 61 7 790 198 6x</p> 	<p>a) 219.960 11 13 7 798 122 →02/2006</p>  <p>a) 428.680 11 13 7 802 669 02/2006→</p>  <p>b) 455.740 11 13 7 535 106 +07 11 9 963 151 M 12x1,5x16</p> <p>b) 110.906 07 11 9 963 151 CU A 12x17x1,5</p>	<p>K:← 301.890 11 14 2 249 534 AW/BS RD PTFE/ACM 55x68x8</p> <p>K:→ 272.091 11 14 7 794 168 SP LD PTFE 90</p>	<p>TLS 727.471</p> 

BMW**M57 D30 (306D4)**

6 Cyl. **2993 ccm**
Cyl. 84,0 Ø

335 d (E90/91/92/93)

09/2008 → 12/2011

535 d (E60/61)

09/2004 → 12/2010

ES⊕ **181.850**
11 12 0 393 750
E60/61



CS* **167.180**
11 11 0 395 221

428.440
11 12 7 788 587
→ 0,720 mm
→ 0,830 mm
1,45 mm $\frac{\pm}{\pm}$ 84,5 Ø
1 ▽

428.450
11 12 7 788 588
→ 0,840 mm
→ 0,930 mm
1,55 mm $\frac{\pm}{\pm}$ 84,5 Ø
2 ▽

428.460
11 12 7 788 589
→ 0,940 mm
→ 1,040 mm
1,65 mm $\frac{\pm}{\pm}$ 84,5 Ø
3 ▽

ZKS **802.801**
11 12 9 067 790
M 12x1,5x147



ZKHS **157.680**
11 12 2 247 447



060.062
11 12 7 796 378

**M57 D30 (306D5)**

6 Cyl. **2993 ccm**
Cyl. 84,0 Ø

335 d (E90/91/92/93)

03/2006 → 03/2013

535 d (E60/61)

01/2007 → 12/2010

635 d (E63/64)

07/2007 → 07/2010

X3 30 d (E83)

09/2006 → 08/2008

X3 35 d (E83)

09/2008 → 08/2011

X5 30 d (E70)

10/2007 → 09/2008

X5 35 d (E70)

10/2008 → 07/2013

X6 35 d (E71/72)

01/2008 → 03/2010

ES⊕ **428.640**
11 12 0 421 276



CS* **428.690**
11 11 0 421 208

058.053
11 12 7 801 698
→ 0,770 mm
→ 0,920 mm
1,47 mm $\frac{\pm}{\pm}$
1 ⊗

058.143
11 12 7 801 699
→ 0,920 mm
→ 1,030 mm
1,57 mm $\frac{\pm}{\pm}$
2 ⊗

058.193
11 12 7 801 700
→ 1,030 mm
→ 1,180 mm
1,67 mm $\frac{\pm}{\pm}$
3 ⊗

058.223
11 12 7 801 701
→ 1,180 mm
→ 1,77 mm $\frac{\pm}{\pm}$

ZKS **234.640**
11 12 7 798 532
M 12x1,5x217



















ZKHS **157.680**
11 12 2 247 447



060.062
11 12 7 796 378



BMW

			<p>a) </p> <p>b) </p>	<p>K: </p> <p>N: </p>	
<p>VAS 152.390 11 34 9 071 732 FPM</p> <p>157.560 11 34 2 247 171 FPM 24x</p>	<p>066.650 11 62 7 795 091 3x</p> 	<p>AAS 228.690 11 61 7 790 198 (6x) +11 61 2 246 945 (6x) +11 61 2 245 439 (1x)</p>  <p>074.990 11 61 7 790 198 6x</p> 	<p>a) 151.900 11 13 7 788 439</p>  <p>b) 455.740 11 13 7 535 106 +07 11 9 963 151 M 12x1,5x16</p> <p>b) 110.906 07 11 9 963 151 CU A 12x17x1,5</p>	<p>K:← 301.890 11 14 2 249 534 AW/BS RD PTFE/ACM 55x68x8</p> <p>K:→ 073.910 11 14 7 787 262 IWD LD PTFE/FPM 90</p>	
<p>VAS 152.390 11 34 9 071 732 FPM</p> <p>157.560 11 34 2 247 171 FPM 24x</p>	<p>333.150 11 62 7 799 728 3x</p> 	<p>AAS 228.690 11 61 7 790 198 (6x) +11 61 2 246 945 (6x) +11 61 2 245 439 (1x)</p>  <p>074.990 11 61 7 790 198 6x</p> 	<p>a) 428.680 11 13 7 802 669</p>  <p>b) 455.740 11 13 7 535 106 +07 11 9 963 151 M 12x1,5x16</p> <p>b) 110.906 07 11 9 963 151 CU A 12x17x1,5</p>	<p>K:← 301.890 11 14 2 249 534 AW/BS RD PTFE/ACM 55x68x8</p> <p>K:→ 272.091 11 14 7 794 168 SP LD PTFE 90</p>	

BMW

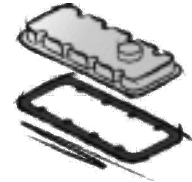
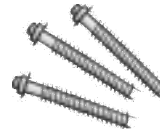
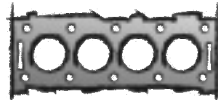
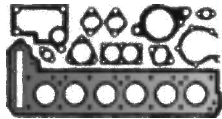

N57 D30 A

6 Cyl. **2993 ccm**
Cyl. 84,0 Ø

325 d (E90/91/92/93)
09/2009 → 12/2013

330 d (E90/91/92/93)
06/2005 → 12/2013

330 d (F30/31/34/35)
07/2012 →

430 d (F32/33/36/82/83)
11/2013 →

525 d (F10/11/18)
03/2010 → 08/2011

530 d (F07/10/11/18)
08/2009 → 02/2017

730 d (F01-F04)
02/2008 → 05/2015

X3 30 d (F25)
04/2011 → 08/2017

X4 30 d (F26)
04/2014 → 03/2018

X5 25 d (F15/85)
04/2014 → 07/2018

X5 30 d (E70)
10/2008 → 07/2013

X5 30 d (F15/85)
08/2013 → 07/2018

X6 30 d (E71/72)
04/2010 → 07/2014

X6 30 d (F16/86)
08/2014 → 07/2019

ES⊕ **373.380**
11 12 8 508 558



ES⊕ **456.240**
10/2012→



CS* **584.450**
11 11 8 508 077

CS* **456.250**
09/2010→

477.312

11 12 7 809 755



1,45 mm $\frac{+}{-}$ 84,7 Ø
1 ⊗

713.163

11 12 8 509 152



1,45 mm $\frac{+}{-}$ 85 Ø
1 ⊗

477.322

11 12 7 809 756



1,55 mm $\frac{+}{-}$ 84,7 Ø
2 ⊗

713.173

11 12 8 509 153



1,55 mm $\frac{+}{-}$ 85 Ø
2 ⊗

477.332

11 12 7 809 757



1,65 mm $\frac{+}{-}$ 84,7 Ø
3 ⊗

713.183

11 12 8 509 154



1,65 mm $\frac{+}{-}$ 85 Ø
3 ⊗

ZKS 233.380

11 12 8 513 130

M 12x1,5x200



ZKHS 369.460

11 12 7 823 943

→12/2010

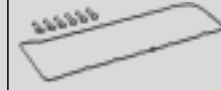













ZKHS 255.130

11 12 8 515 732

12/2010→



BMW

			<p>a) </p> <p>b) </p>	<p>K: </p> <p>N: </p>	
<p>VAS 584.820 11 34 7 812 926</p> <p>539.420 FPM 24x</p>	<p>503.721 11 62 7 811 221 3x</p> 	<p>584.600 11 61 7 807 480 6x</p> 	<p>a) 584.140 11 13 7 809 836</p>  <p>b) 455.740 11 13 7 535 106 +07 11 9 963 151 M 12x1,5x16</p> <p>b) 110.906 07 11 9 963 151 CU A 12x17x1,5</p>	<p>K:← 584.160 11 11 7 802 665 AW/BS OF RD FPM 55x68x8</p> <p>K:→ 492.060 11 14 7 797 490 AW/BS OF LD FPM 90x104x9</p>	<p>TLS 452.390</p> 

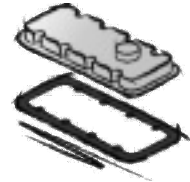
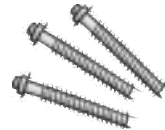
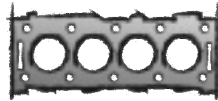
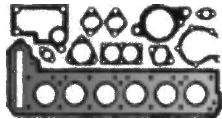
BMW**N57 D30 B**

6 Cyl. 2993 ccm
Cyl. 84,0 Ø

335 d (F30/31/34/35)

07/2013 →

435 d (F32/33/36/82/83)

11/2013 →

535 d (F07/10/11/18)

03/2010 → 02/2017

640 d (F06/12/13)

09/2011 → 10/2018

740 d (F01-F04)

09/2009 → 06/2015

X3 35 d (F25)

10/2011 → 08/2017

X4 35 d (F26)

04/2014 → 03/2018

X5 40 d (E70)

09/2010 → 06/2013

X5 40 d (F15/85)

12/2013 → 07/2018

X6 40 d (E71/72)

07/2009 → 06/2014

X6 40 d (F16/86)

12/2014 → 07/2019

ES⊕ **373.380**
11 12 8 508 558
E90/91/92/93
E70/71/72
F10/11/07
F01-04



ES⊕ **522.130**
F01-04
F06/12/13
F16/25/26
F30/31/33/34/36
F10/11



CS* **456.250**
F16/25/26
F01-04
F06/12/13
F30/31/33/34/36
F10/11

CS* **584.450**
11 11 8 508 077
E70/71/72
F01-04
F10/11/07
E90/91/92/93

477.312
11 12 7 809 755
 0,900 mm
1,45 mm ± 84,7 Ø
1 ⊗



E70/71/72
E90/91/92/93
F01-04
F10/11/07

713.163

11 12 8 509 152
 0,900 mm
1,45 mm ± 85 Ø
1 ⊗



F30/31/33/34/36
F06/12/13
F16/25/26
F10/11
F01-04

477.322

11 12 7 809 756
 0,910 mm
→
1,030 mm
1,55 mm ± 84,7 Ø
2 ⊗



E90/91/92/93
F01-04
F10/11/07
E70/71/72

713.173

11 12 8 509 153
 0,900 mm
→
1,030 mm
1,55 mm ± 85 Ø
2 ⊗

F01-04
F06/12/13
F30/31/33/34/36
F10/11
F16/25/26

477.332

11 12 7 809 757
 1,040 mm
→
1,180 mm
1,65 mm ± 84,7 Ø
3 ⊗



E70/71/72
E90/91/92/93
F01-04
F10/11/07

ZKS **233.380**
11 12 8 513 130
M 12x1,5x200





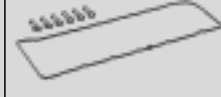









ZKHS **369.460**
11 12 7 823 943
→12/2010



ZKHS **255.130**
11 12 8 515 732
12/2010→

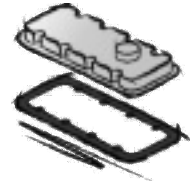

			<p>a) </p> <p>b) </p>	<p>K: </p> <p>N: </p>	
<p>VAS 584.820 11 34 7 812 926</p> <p>539.420 FPM 24x</p>	<p>503.721 11 62 7 811 221 3x</p> 	<p>584.600 11 61 7 807 480 E70/71/72 F01-04 F10/11/07 E90/91/92/93 6x</p> 	<p>a) 584.140 11 13 7 809 836</p>  <p>b) 455.740 11 13 7 535 106 +07 11 9 963 151 M 12x1,5x16</p> <p>b) 110.906 07 11 9 963 151 CU A 12x17x1,5</p>	<p>K:← 584.160 11 11 7 802 665 AW/BS OF RD FPM 55x68x8</p> <p>K:→ 492.060 11 14 7 797 490 AW/BS OF LD FPM 90x104x9</p>	<p>TLS 527.270</p> 

BMW**N57 D30 B**

6 Cyl. **2993 ccm**
Cyl. 84,0 Ø

335 d (F30/31/34/35)

07/2013 →

435 d (F32/33/36/82/83)

11/2013 →

535 d (F07/10/11/18)

03/2010 → 02/2017

640 d (F06/12/13)

09/2011 → 10/2018

740 d (F01-F04)

09/2009 → 06/2015

X3 35 d (F25)

10/2011 → 08/2017

X4 35 d (F26)

04/2014 → 03/2018

X5 40 d (E70)

09/2010 → 06/2013

X5 40 d (F15/85)

12/2013 → 07/2018

X6 40 d (E71/72)

07/2009 → 06/2014

X6 40 d (F16/86)

12/2014 → 07/2019

ES⊕ **373.380**
11 12 8 508 558
E90/91/92/93
E70/71/72
F10/11/07
F01-04



ES⊕ **522.130**
F01-04
F06/12/13
F16/25/26
F30/31/33/34/36
F10/11



CS* **456.250**
F16/25/26
F01-04
F06/12/13
F30/31/33/34/36
F10/11

CS* **584.450**
11 11 8 508 077
E70/71/72
F01-04
F10/11/07
E90/91/92/93

713.183

11 12 8 509 154
 1,030 mm
→
1,180 mm
1,65 mm $\frac{3}{4}$ 85 Ø
3 ⊗
F10/11
F01-04
F30/31/33/34/36
F06/12/13
F16/25/26

ZKS 233.380

11 12 8 513 130
M 12x1,5x200

**ZKHS 369.460**

11 12 7 823 943
→12/2010

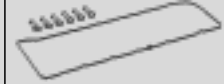
**ZKHS 255.130**

11 12 8 515 732
12/2010→

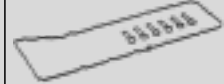
**N57 D30 C**

6 Cyl. **2993 ccm**
Cyl. 84,0 Ø

750 d (F01-F04)

07/2012 → 12/2015

M 550 d (F10/11/18)

03/2012 → 02/2017

X5 M 50 d (E70)

08/2011 → 06/2013

X5 M 50 d (F15/85)

12/2013 → 07/2018

X6 M 50 d (E71/72)

08/2011 → 06/2014

X6 M 50 d (F16/86)

08/2014 → 07/2019

ES⊕ **527.250**



CS* **522.120**

736.261

11 12 8 506 602
1,57 mm $\frac{3}{4}$
2 ⊗

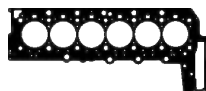
**736.271**

11 12 8 506 603
1,68 mm $\frac{3}{4}$
3 ⊗

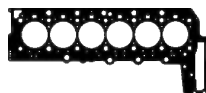
**ZKS 469.830**

11 12 8 570 942
M 12x1,5x179

**ZKHS 255.130**

11 12 8 515 732

**N51 B30 A**

6 Cyl. **2996 ccm**
Cyl. 85,0 Ø

128 i (E81/82/87/88)

10/2007 → 10/2013

328 i (E90/91/92/93)

06/2006 → 12/2013

ES⊕ **339.650**
11 12 7 571 963
+11 34 0 035 853
+11 34 0 034 068



CS* **902.230**
11 11 7 548 101
01/2009→

005.510

11 12 7 553 209
1,16 mm $\frac{3}{4}$ 85,8 Ø

















**ZKS 270.190**

11 12 7 548 799
M 10x1,5x125

**ZKHS 584.950**

11 12 7 582 245

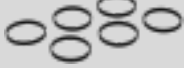

			<p>a) </p> <p>b) </p>	<p>K: </p> <p>N: </p>	
<p>VAS 584.820 11 34 7 812 926</p> <p>539.420 FPM 24x</p>	<p>503.721 11 62 7 811 221 3x</p> 	<p>584.600 11 61 7 807 480 E70/71/72 F01-04 F10/11/07 E90/91/92/93 6x</p> 	<p>a) 584.140 11 13 7 809 836</p>  <p>b) 455.740 11 13 7 535 106 +07 11 9 963 151 M 12x1,5x16</p> <p>b) 110.906 07 11 9 963 151 CU A 12x17x1,5</p>	<p>K:← 584.160 11 11 7 802 665 AW/BS OF RD FPM 55x68x8</p> <p>K:→ 492.060 11 14 7 797 490 AW/BS OF LD FPM 90x104x9</p>	<p>TLS 527.270</p> 
<p>VAS 584.820 11 34 7 812 926</p> <p>539.420 FPM 24x</p>	<p>388.724 11 62 8 579 891 3x</p> 		<p>a) 584.140 11 13 7 809 836</p>  <p>b) 455.740 11 13 7 535 106 +07 11 9 963 151 M 12x1,5x16</p> <p>b) 110.906 07 11 9 963 151 CU A 12x17x1,5</p>	<p>K:← 584.160 11 11 7 802 665 AW/BS OF RD FPM 55x68x8</p> <p>K:→ 492.060 11 14 7 797 490 AW/BS OF LD FPM 90x104x9</p>	<p>TLS 523.750</p>
<p>VAS 364.500 11 34 0 034 068 FPM E</p> <p>VAS 660.360 11 34 0 035 853 FPM A</p>	<p>504.380 18 40 7 530 606 6x</p> 	<p>AAS 537.890 11 61 7 547 242</p> 	<p>a) 545.840 11 13 7 548 031</p>  <p>b) 455.740 11 13 7 535 106 +07 11 9 963 151 M 12x1,5x16</p> <p>b) 110.906 07 11 9 963 151 CU A 12x17x1,5</p>	<p>K:← 257.400 11 11 7 511 395 ASW RD PTFE/ACM 65x79x20 →02/2011</p> <p>K:← 902.860 11 11 8 618 864 ASW RD PTFE/ACM 65x79x10 02/2011→</p> <p>K:→ 751.610 11 11 7 587 168 AW OF LD FPM 90x110x8</p>	

BMW

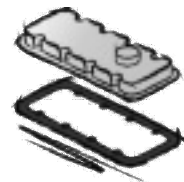
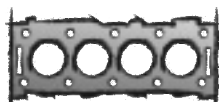
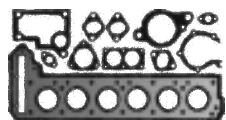

N52 B30
N52 B30 A/AE/BF
 6 Cyl. 2996 ccm
 Cyl. 85,0 Ø

125 i (E81/82/87/88)
 12/2007 → 10/2013

128 i (E81/82/87/88)
 10/2007 → 10/2013

130 i (E81/87)
 09/2005 → 12/2011

325 i (E90/91/92/93)
 09/2005 → 08/2006

328 i (E90/91/92/93)
 06/2006 → 06/2013

330 i (E90/91/92/93)
 12/2004 → 10/2013

525 i (E60/61)
 03/2005 → 03/2007

528 i (E60/61)
 09/2006 → 12/2009

528 i (F10/11/18)
 10/2009 → 08/2011

530 i (E60/61)
 09/2004 → 05/2010

530 i (F10/11/18)
 03/2010 → 06/2013

630 i (E63/64)
 09/2004 → 08/2010

730 i / Li (E65/E66)
 03/2005 → 08/2008

730 i (F01-F04)
 09/2009 → 06/2015

X1 25 d (E84)
 03/2010 → 08/2011

X1 28 i (E84)
 09/2009 → 08/2011

X3 28 i (F25)
 01/2011 → 10/2012

X3 30 i (E83)
 08/2006 → 08/2010

X5 3.0 i (E70)
 10/2006 → 09/2008

X5 30 i (E70)
 02/2007 → 12/2012

Z4 3.0 i (E85)
 09/2005 → 12/2008

Z4 3.0 i (E86)
 03/2006 → 01/2009

Z4 30 i (E89)
 02/2009 → 08/2011

ES⊕ **537.850**
 →03/2006



ES **236.280**
 11 12 7 548 921
 →06/2006

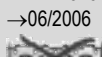

ES⊕ **660.370**
 11 12 7 548 921
 +11 34 0 035 853
 +11 34 0 034 068
 03/2006→
 →06/2006



ES⊕ **339.650**
 11 12 7 571 963
 +11 34 0 035 853
 +11 34 0 034 068
 N52N
 06/2006→



CS* **902.230**
 11 11 7 548 101
 →02/2011

CS* **801.470**
 11 11 7 548 101
 02/2011→

005.510
 11 12 7 553 209
 1,16 mm ± 85,8 Ø



512.330
 11 12 7 555 758
 1,50 mm ± 85,8 Ø
 →01/2011

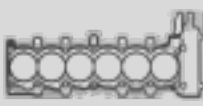

ZKS 270.190
 11 12 7 548 799
 M 10x1,5x125

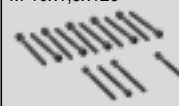



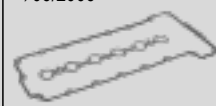



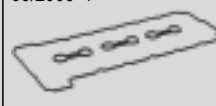



ZKHS 534.310
 11 12 7 581 215
 →06/2006





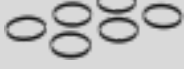





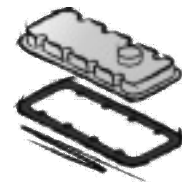
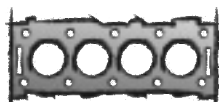
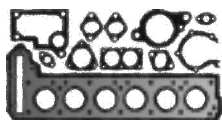







ZKHS 584.950
 11 12 7 582 245
 N52N
 06/2006→



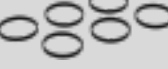



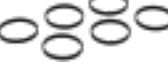



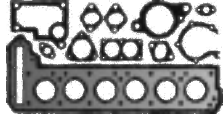
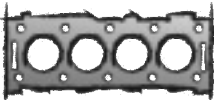







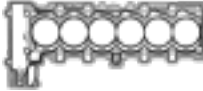









			<p>a) </p> <p>b) </p>	<p>K: </p> <p>N: </p>	
<p>VAS 364.500 11 34 0 034 068 FPM 03/2006→ E</p> <p>VAS 367.480 11 34 0 032 582 FPM →03/2006 A E</p> <p>VAS 660.360 11 34 0 035 853 FPM 03/2006→ A</p>	<p>504.380 18 40 7 530 606 6x</p> 	<p>AAS 537.890 11 61 7 547 242</p> 	<p>a) 298.130 11 13 7 600 482 7 F01/02/03/04 X3 (F25) 5 F10/11</p>  <p>a) 545.840 11 13 7 548 031</p>  <p>b) 455.740 11 13 7 535 106 +07 11 9 963 151 M 12x1,5x16</p> <p>b) 110.906 07 11 9 963 151 CU A 12x17x1,5</p>	<p>K:← 257.400 11 11 7 511 395 ASW RD PTFE/ACM 65x79x20 →02/2011</p> <p>K:← 902.860 11 11 8 618 864 ASW RD PTFE/ACM 65x79x10 02/2011→</p> <p>K:→ 751.610 11 11 7 587 168 AW OF LD FPM 90x110x8</p>	

BMW

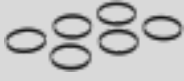

			<p>a) </p> <p>b) </p>	<p>K: </p> <p>N: </p>	
<p>VAS 364.500 11 34 0 034 068 FPM 03/2006→ E</p> <p>VAS 367.480 11 34 0 032 582 FPM →03/2006 A E</p> <p>VAS 660.360 11 34 0 035 853 FPM 03/2006→ A</p>	<p>504.380 18 40 7 530 606 6x</p> 	<p>AAS 537.890 11 61 7 547 242</p> 	<p>a) 298.130 11 13 7 600 482 7 F01/02/03/04 5 F10/11</p>  <p>a) 545.840 11 13 7 548 031</p>  <p>b) 455.740 11 13 7 535 106 +07 11 9 963 151 M 12x1,5x16</p> <p>b) 110.906 07 11 9 963 151 CU A 12x17x1,5</p>	<p>K:← 257.400 11 11 7 511 395 ASW RD PTFE/ACM 65x79x20 →02/2011</p> <p>K:← 902.860 11 11 8 618 864 ASW RD PTFE/ACM 65x79x10 02/2011→</p> <p>K:→ 751.610 11 11 7 587 168 AW OF LD FPM 90x110x8</p>	
<p>VAS 364.500 11 34 0 034 068 FPM 03/2006→ E</p> <p>VAS 367.480 11 34 0 032 582 FPM →03/2006 A E</p> <p>VAS 660.360 11 34 0 035 853 FPM 03/2006→ A</p>	<p>504.380 18 40 7 530 606 6x</p> 	<p>AAS 537.890 11 61 7 547 242</p> 	<p>a) 545.840 11 13 7 548 031</p>  <p>b) 455.740 11 13 7 535 106 +07 11 9 963 151 M 12x1,5x16</p> <p>b) 110.906 07 11 9 963 151 CU A 12x17x1,5</p>	<p>K:← 257.400 11 11 7 511 395 ASW RD PTFE/ACM 65x79x20 →02/2011</p> <p>K:← 902.860 11 11 8 618 864 ASW RD PTFE/ACM 65x79x10 02/2011→</p> <p>K:→ 751.610 11 11 7 587 168 AW OF LD FPM 90x110x8</p>	

BMW  Das Original				
N53 B30 6 Cyl. 2996 ccm Cyl. 85,0 Ø	ES⊕ 740.280 11 12 7 561 438  CS* 902.230 11 11 7 548 101 →02/2011 CS* 801.470 11 11 7 548 101 02/2011→	005.510 11 12 7 553 209 1,16 mm $\frac{\pm}{\text{mm}}$ 85,8 Ø 	ZKS 270.190 11 12 7 548 799 M 10x1,5x125 	740.290 11 12 7 544 368 
N53 B30 A 6 Cyl. 2996 ccm Cyl. 85,0 Ø 325 i (E90/91/92/93) 10/2006 → 12/2013 330 i (E90/91/92/93) 03/2007 → 10/2013 523 i (F10/11/18) 06/2009 → 08/2011 525 i (E60/61) 01/2007 → 12/2010 528 i (F07/10/11/18) 11/2009 → 08/2011 530 i (E60/61) 09/2006 → 12/2010 530 i (F10/11/18) 05/2011 → 06/2013 630 i (E63/64) 09/2007 → 08/2010	ES⊕ 740.280 11 12 7 561 438  CS* 902.230 11 11 7 548 101 →02/2011 CS* 801.470 11 11 7 548 101 02/2011→	005.510 11 12 7 553 209 1,16 mm $\frac{\pm}{\text{mm}}$ 85,8 Ø 	ZKS 270.190 11 12 7 548 799 M 10x1,5x125 	740.290 11 12 7 544 368 

			<p>a) </p> <p>b) </p>	<p>K: </p> <p>N: </p>	
<p>VAS 364.500 11 34 0 034 068 FPM E</p> <p>VAS 660.360 11 34 0 035 853 FPM A</p>	<p>504.380 18 40 7 530 606 6x</p> 	<p>AAS 537.890 11 61 7 547 242</p> 	<p>a) 545.840 11 13 7 548 031</p>  <p>b) 455.740 11 13 7 535 106 +07 11 9 963 151 M 12x1,5x16</p> <p>b) 110.906 07 11 9 963 151 CU A 12x17x1,5</p>	<p>K:← 257.400 11 11 7 511 395 ASW RD PTFE/ACM 65x79x20 →02/2011</p> <p>K:← 902.860 11 11 8 618 864 ASW RD PTFE/ACM 65x79x10 02/2011→</p> <p>K:→ 751.610 11 11 7 587 168 AW OF LD FPM 90x110x8</p>	
<p>VAS 364.500 11 34 0 034 068 FPM E</p> <p>VAS 660.360 11 34 0 035 853 FPM A</p>	<p>504.380 18 40 7 530 606 6x</p> 	<p>AAS 537.890 11 61 7 547 242</p> 	<p>a) 298.130 11 13 7 600 482 5 F10/11</p>  <p>a) 545.840 11 13 7 548 031</p>  <p>b) 455.740 11 13 7 535 106 +07 11 9 963 151 M 12x1,5x16</p> <p>b) 110.906 07 11 9 963 151 CU A 12x17x1,5</p>	<p>K:← 257.400 11 11 7 511 395 ASW RD PTFE/ACM 65x79x20 →02/2011</p> <p>K:← 902.860 11 11 8 618 864 ASW RD PTFE/ACM 65x79x10 02/2011→</p> <p>K:→ 751.610 11 11 7 587 168 AW OF LD FPM 90x110x8</p>	

BMW

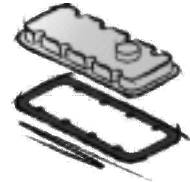
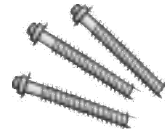
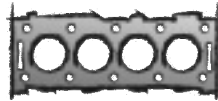
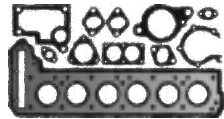

M60 B30 M60 B30 (308S1)

8 Cyl. 2997 ccm
Cyl. 84,0 Ø

- 530 i (E34)**
09/1992 → 07/1996
- 730 i, iL (E32)**
04/1992 → 09/1994
- 730 i, iL (E38)**
03/1994 → 11/2001

ES⊕ **914.500**
11 12 1 736 906



CS* **914.518**
11 11 9 070 240

812.296
11 12 1 736 346
1,74 mm $\frac{\pm}{\text{mm}}$ 85 Ø
L Cyl. 5-8



812.288
11 12 1 736 345
1,74 mm $\frac{\pm}{\text{mm}}$ 85 Ø
R Cyl. 1-4

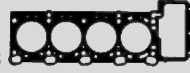

ZKS **802.790**
11 12 1 729 246
M 10x1,5x110
2x



ZKHS **318.620**
11 12 9 069 872
+11 12 1 437 395 (16x)
L



ZKHS **318.610**
11 12 9 069 871
+11 12 1 437 395 (16x)
R



830.305
11 12 1 747 022
L



830.313
11 12 1 747 021
R

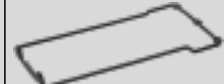

830.283
11 12 1 733 969
↑
2x



B58 B30 A

6 Cyl. 2998 ccm
Cyl. 82,0 Ø

- 340 i (F30/31/34/35)**
07/2015 →
- 440 i (F32/33/36/82/83)**
03/2016 →
- 540 i (G30/31)**
09/2016 →
- 640 i (G32)**
06/2017 → 06/2020
- 740 i (G11/12)**
07/2015 → 02/2019
- M 140 i (F20/21)**
09/2015 →
- M 240 i (F22/23)**
09/2015 →
- X3 M 40 i (G01)**
08/2017 → 08/2019
- X4 M 40 i (G02)**
04/2018 → 08/2019

ES⊕ **794.710**



CS* **794.700**
OKS **784.680**
11 42 8 583 897

298.551
11 12 8 654 268
0,70 mm $\frac{\pm}{\text{mm}}$ 83 Ø

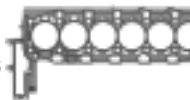

377.290
11 12 8 654 269
1,00 mm $\frac{\pm}{\text{mm}}$ 83 Ø

ZKS **794.480**
1112 8 644 674 (14x)
M 11x188















ZKHS **773.910**
773.890
11 12 8 621 951



773.900
11 12 8 638 124

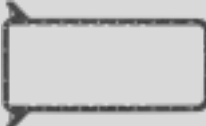

			<p>a) </p> <p>b) </p>	<p>K: </p> <p>N: </p>	
<p>VAS 424.800 FPM 2x</p> <p>403.730 11 34 2 245 151 FPM 32x</p>	<p>638.181 11 62 7 505 789 3x</p>  <p>638.191 11 62 7 509 677 1x</p> 	<p>266.250 11 61 1 433 328 4x</p> 	<p>a) 803.780 11 13 1 742 109</p>  <p>a) 634.450 11 13 1 436 324</p>  <p>b) 774.390 11 13 1 273 093 M 12x1,5x18</p> <p>b) 110.906 07 11 9 963 151 CU A 12x17x1,5</p> <p>b) 238.708 07 11 9 963 130 AL A 12x15,5x1,5</p>	<p>K:← 586.676 11 14 1 275 466 A/BS RD FPM 48x65x10</p> <p>K:→ 818.399 11 14 1 713 730 A/BS LD FPM 100x125x13</p>	
<p>VAS 364.500 11 34 0 034 068 FPM E</p> <p>VAS 660.360 11 34 0 035 853 FPM A</p>	<p>259.972 11 65 7 643 149</p> 		<p>a) 036.164 11 12 1 262 571 Dirko HT / EU</p> <p>a) 510.031 11 12 1 262 571 Dirko HT / USA/CDN/MEX</p> <p>a) 527.291 11 12 1 262 571 Dirko HT / RU</p> <p>a) 648.661 11 12 1 262 571 Dirko HT / BR</p> <p>b) 455.740 11 13 7 535 106 +07 11 9 963 151 M 12x1,5x16</p> <p>b) 110.507 07 11 9 963 132 CU A 12x16x1</p>	<p>K:← 575.970 11 11 8 604 931 ASW RD PTFE/ACM 55x68x8</p> <p>K:→ 586.550 11 14 8 602 594 ASW LD PTFE 90x104x8,5</p>	

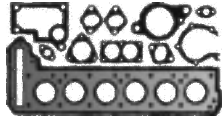
BMW**B58 B30 B**

6 Cyl. **2998 ccm**
Cyl. 82,0 Ø

- M 240 i (G42)**
08/2021 →
- M 340 i (G20/21/80)**
03/2019 →
- M 340 i (G20)**
11/2020 →
- M 440 (G22/23)**
11/2020 →
- M 440 i (G22/23)**
07/2020 →
- M 440 i (G26)**
07/2021 →
- X3 M 40 i (G01)**
09/2019 →
- X4 M 40 i (G02)**
09/2019 →
- Z4 M 40 i (G29)**
03/2019 →

CS* **794.700**
OKS **784.680**
11 42 8 583 897

377.290
11 12 8 654 269
1,00 mm $\frac{1}{16}$ 83 Ø



ZKS **794.480**
1112 8 644 674 (14x)
M 11x188

**B58 B30 C**





6 Cyl. **2998 ccm**
Cyl. 82,0 Ø

- 540 i (G30/31)**
09/2016 →
- 545 e (G30/31)**
11/2020 →
- 630 i (G32)**
07/2019 →
- 640 i (G32)**
06/2017 →
- 740 i (G11/12)**
03/2019 →
- 745 e (G11/12)**
03/2019 →
- 840 i (G14/15/16)**
07/2019 →
- X5 40 i (G05)**
08/2018 →
- X5 45 e (G05)**
06/2019 →
- X6 40 i (G06)**
08/2019 →
- X7 40 i (G07)**
03/2019 →
- Z4 M 40 i (G29)**
11/2018 →

CS* **794.700**
OKS **784.680**
11 42 8 583 897

ZKS **794.480**
1112 8 644 674 (14x)
M 11x188



			<p>a) </p> <p>b) </p>	<p>K: </p> <p>N: </p>	
<p>VAS 364.500 11 34 0 034 068 FPM E</p> <p>VAS 660.360 11 34 0 035 853 FPM A</p>			<p>a) 036.164 11 12 1 262 571 Dirko HT / EU</p> <p>a) 510.031 11 12 1 262 571 Dirko HT / USA/CDN/MEX</p> <p>a) 527.291 11 12 1 262 571 Dirko HT / RU</p> <p>a) 648.661 11 12 1 262 571 Dirko HT / BR</p> <p>b) 455.740 11 13 7 535 106 +07 11 9 963 151 M 12x1,5x16</p> <p>b) 110.507 07 11 9 963 132 CU A 12x16x1</p>	<p>K:← 575.970 11 11 8 604 931 ASW RD PTFE/ACM 55x68x8</p> <p>K:→ 586.550 11 14 8 602 594 ASW LD PTFE 90x104x8,5</p>	
<p>VAS 364.500 11 34 0 034 068 FPM E</p> <p>VAS 660.360 11 34 0 035 853 FPM A</p>			<p>a) 036.164 11 12 1 262 571 Dirko HT / EU</p> <p>a) 510.031 11 12 1 262 571 Dirko HT / USA/CDN/MEX</p> <p>a) 527.291 11 12 1 262 571 Dirko HT / RU</p> <p>a) 648.661 11 12 1 262 571 Dirko HT / BR</p> <p>b) 455.740 11 13 7 535 106 +07 11 9 963 151 M 12x1,5x16</p> <p>b) 110.507 07 11 9 963 132 CU A 12x16x1</p>	<p>K:← 575.970 11 11 8 604 931 ASW RD PTFE/ACM 55x68x8</p> <p>K:→ 586.550 11 14 8 602 594 ASW LD PTFE 90x104x8,5</p>	

BMW

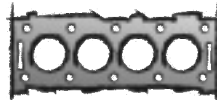
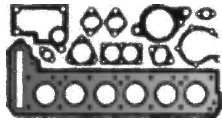

S52 B32
S52 B32 (326S2)
6 Cyl. 3152 ccm
Cyl. 86,4 Ø

M3 3.2 (E36)
09/1996 → 09/1999
M3 3.2 8E36)
06/1996 → 04/1999
Z3 (E36)
02/1998 → 06/2000

ES⊕ **568.850**
11 12 9 069 861
10/1995→

914.033
USA
11 12 1 405 106
1,74 mm ±

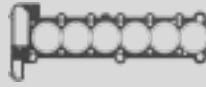

ZKS 802.740
11 12 1 721 938
M 10x1,5x95



ZKHS 302.340
11 12 0 034 107
→09/1995



ZKHS 318.550
11 12 0 034 107
+11 12 1 437 395 (15x)
→09/1995



ZKHS 318.580
11 12 0 034 108
+11 12 1 437 395 (15x)
09/1995→

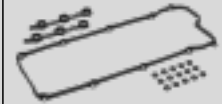

ZKHS 302.350
11 12 0 034 108
10/1995→



147.610
11 12 1 738 701
→09/1995

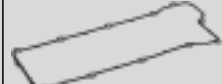

425.370
11 12 1 703 342
10/1995→

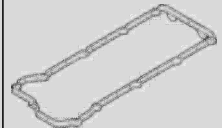

827.312
11 12 1 735 721
→09/1995
2x











425.390
11 12 1 748 872
09/1995→
2x

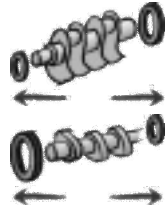

436.010
11 12 1 437 395
15x

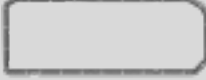

			<p>a) </p> <p>b) </p>	<p>K: </p> <p>N: </p>	
<p>VAS 424.820 FPM 403.730 11 34 2 245 151 FPM 24x</p>	<p>147.581 11 62 1 744 252 2x </p>	<p>147.590 11 61 1 740 069 2x </p>	<p>a) 424.510 11 13 9 065 875 </p> <p>b) 774.390 11 13 1 273 093 M 12x1,5x18</p> <p>b) 110.906 07 11 9 963 151 CU A 12x17x1,5</p> <p>b) 238.708 07 11 9 963 130 AL A 12x15,5x1,5</p>	<p>K:← 586.676 11 14 1 275 466 A/BS RD FPM 48x65x10</p> <p>K:→ 301.870 11 14 2 249 533 A/BS LD PTFE/FPM 90x110x12</p>	

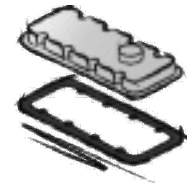
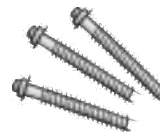
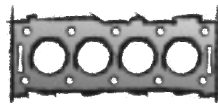
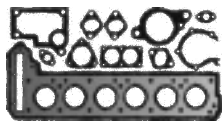
BMW

S50 B32
S50 B32 (326S1)/(326S3)

6 Cyl. 3201 ccm
Cyl. 86,4 Ø

M3 3.2 (E36)

10/1995 → 09/1999

Z3 (E36)

02/1998 → 06/2001

Z3 M 3.2 (E36)

01/1997 → 06/2000

ES⊕ **408.000**
11 12 1 405 282
CS* **257.360**
11 11 1 402 381

889.194
11 12 1 405 748
1,74 mm \pm



894.738
11 12 1 404 358

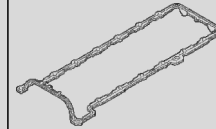

407.330
11 12 1 402 637
2x



767.891
11 12 1 721 879
20x



S54 B32 (326S4)

6 Cyl. 3246 ccm
Cyl. 87,0 Ø

M3 3.2 (E46)

07/2000 → 08/2006

M3 CSL (E46)

05/2003 → 12/2003

Z3 (E36)

09/2000 → 12/2002

Z3 M 3.2 (E36)

09/2000 → 06/2003

Z4 3.2 i (E85)

09/2005 → 12/2007

Z4 M 3.2 (E85)

01/2006 → 08/2008

Z4 M 3.2 (E86)

03/2006 → 12/2008

ES⊕ **074.550**
11 12 7 831 920
+11 12 7 835 918
CS* **073.611**
11 11 0 302 722

021.660
11 12 7 835 918
0,64 mm \pm



ZKHS **353.540**
11 12 7 832 034



074.530
11 12 7 832 034



612.001
11 12 7 831 271
6x



















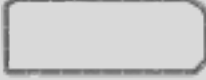





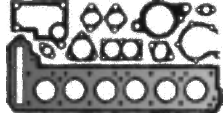

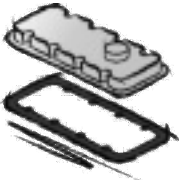

074.410
11 12 7 830 972
13x





























436.010
11 12 1 437 395
2x

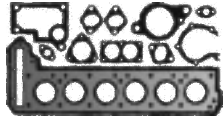
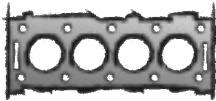

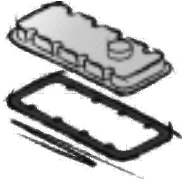









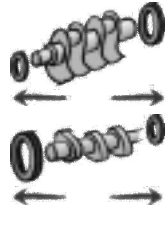

			<p>a) </p> <p>b) </p>	<p>K: </p> <p>N: </p>	
<p>VAS 424.820 FPM 403.730 11 34 2 245 151 FPM 24x</p>	<p>833.169 11 62 1 317 631 6x</p> 		<p>a) 424.510 11 13 9 065 875</p>  <p>b) 774.390 11 13 1 273 093 M 12x1,5x18</p> <p>b) 110.906 07 11 9 963 151 CU A 12x17x1,5</p> <p>b) 238.708 07 11 9 963 130 AL A 12x15,5x1,5</p>	<p>K:← 586.676 11 14 1 275 466 A/BS RD FPM 48x65x10</p> <p>K:→ 301.870 11 14 2 249 533 A/BS LD PTFE/FPM 90x110x12</p> <p>K:→ 702.994 11 14 1 706 999 A/BS LD FPM 90x110x12</p>	
<p>VAS 424.820 FPM 403.730 11 34 2 245 151 FPM 24x</p>	<p>074.460 11 62 7 830 667 6x</p> 		<p>a) 424.510 11 13 9 065 875</p>  <p>b) 774.480 07 11 9 919 113 M 12x1,5x12</p> <p>b) 110.906 07 11 9 963 151 CU A 12x17x1,5</p>	<p>K:← 050.260 11 14 2 249 532 AS RD PTFE/ACM 48x65x10</p> <p>K:→ 301.870 11 14 2 249 533 A/BS LD PTFE/FPM 90x110x12</p>	

BMW 				
M30 B34 (346KB) 6 Cyl. 3430 ccm Cyl. 92,0 Ø 535 i (E34) 11/1987 → 02/1993 635 CSi (E24) 12/1977 → 04/1989 735 i, iL (E32) 06/1986 → 07/1992	ES⊕ 444.460 incl. 750.492 11 12 9 059 238 ES⊕ 764.907 11 12 9 059 238 CS* 764.915 11 11 9 059 234 5 E34 7 E32 CS* 888.389 11 11 1 735 046 6 E24	749.370 11 12 1 730 226 1,72 mm $\frac{2}{3}$ 93,5 Ø 750.492 11 12 1 730 227 2,07 mm $\frac{2}{3}$ 93,5 Ø  	ZKS 802.700 11 12 0 621 144 (14x) M 12x1,75x157 	774.715 11 12 1 730 231 
M30 B34 (346TA) 6 Cyl. 3430 ccm Cyl. 92,0 Ø 745 i (E23) 05/1983 → 08/1986	CS* 888.389 11 11 1 735 046	749.370 11 12 1 730 226 1,72 mm $\frac{2}{3}$ 93,5 Ø 05/1982→ 750.492 11 12 1 730 227 2,07 mm $\frac{2}{3}$ 93,5 Ø 05/1982→  	ZKS 802.700 11 12 0 621 144 (14x) M 12x1,75x157 	774.715 11 12 1 730 231 
M30 B34 (346EA)/(346EC)/ (346KA) M30 B35 (Motronic, 10:1) 6 Cyl. 3430 ccm Cyl. 92,0 Ø 535 i (E28) 01/1985 → 12/1987 635 CSi (E24) 12/1977 → 04/1989 635 i (E24) 05/1982 → 06/1987 735 i (E23) 09/1982 → 09/1986 M 535 i (E28) 01/1985 → 12/1987	ES⊕ 827.819 11 12 1 730 780 →08/1986 ES⊕ 444.460 incl. 750.492 11 12 9 059 238 09/1986→ ES⊕ 764.907 11 12 9 059 238 09/1986→ CS* 888.389 11 11 1 735 046	749.370 11 12 1 730 226 1,72 mm $\frac{2}{3}$ 93,5 Ø 05/1982→ 750.492 11 12 1 730 227 2,07 mm $\frac{2}{3}$ 93,5 Ø 05/1982→  	ZKS 802.700 11 12 0 621 144 (14x) M 12x1,75x157 	774.715 11 12 1 730 231 

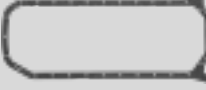
			<p>a) </p> <p>b) </p>	<p>K: </p> <p>N: </p>	
<p>VAS 774.456 11 34 9 059 170</p> <p>553.190 11 34 1 273 501 FPM 12x</p>	<p>762.199 11 62 1 723 656 2x</p> 	<p>774.677 11 61 1 726 016 09/1986→ 6x</p> 	<p>a) 892.122 11 13 1 722 744 5 E34 7 E32</p>  <p>b) 774.390 11 13 1 273 093 M 12x1,5x18</p> <p>b) 110.906 07 11 9 963 151 CU A 12x17x1,5</p> <p>b) 238.708 07 11 9 963 130 AL A 12x15,5x1,5</p>	<p>K:← 586.641 11 14 1 715 101 AW/BS RD FPM 42x62x12</p> <p>K:→ 301.870 11 14 2 249 533 A/BS LD PTFE/FPM 90x110x12</p> <p>K:→ 702.994 11 14 1 706 999 A/BS LD FPM 90x110x12</p>	
<p>VAS 774.456 11 34 9 059 170</p> <p>553.190 11 34 1 273 501 FPM 12x</p>		<p>774.669 11 61 1 730 788 6x</p> 	<p>a) 888.354 11 13 1 730 240</p>  <p>b) 774.390 11 13 1 273 093 M 12x1,5x18</p> <p>b) 110.906 07 11 9 963 151 CU A 12x17x1,5</p> <p>b) 238.708 07 11 9 963 130 AL A 12x15,5x1,5</p> <p>b) 250.007 07 11 9 963 355 AL A 22x27x1,5</p>	<p>K:← 586.641 11 14 1 715 101 AW/BS RD FPM 42x62x12</p> <p>K:→ 301.870 11 14 2 249 533 A/BS LD PTFE/FPM 90x110x12</p> <p>K:→ 702.994 11 14 1 706 999 A/BS LD FPM 90x110x12</p>	
<p>VAS 774.456 11 34 9 059 170</p> <p>553.190 11 34 1 273 501 FPM 12x</p>	<p>762.199 11 62 1 723 656 2x</p>  <p>891.991 11 62 1 723 851 6x</p> 	<p>774.669 11 61 1 730 788 →08/1986 6x</p>  <p>774.677 11 61 1 726 016 09/1986→ 6x</p> 	<p>a) 888.354 11 13 1 730 240</p>  <p>b) 774.390 11 13 1 273 093 M 12x1,5x18</p> <p>b) 110.906 07 11 9 963 151 CU A 12x17x1,5</p> <p>b) 238.708 07 11 9 963 130 AL A 12x15,5x1,5</p> <p>b) 250.007 07 11 9 963 355 AL A 22x27x1,5</p>	<p>K:← 586.641 11 14 1 715 101 AW/BS RD FPM 42x62x12</p> <p>K:→ 301.870 11 14 2 249 533 A/BS LD PTFE/FPM 90x110x12</p> <p>K:→ 702.994 11 14 1 706 999 A/BS LD FPM 90x110x12</p>	

<p>BMW</p> 				
<p>M30 B35 (Motronic,9.2:1) 6 Cyl. 3430 ccm Cyl. 92,0 Ø</p> <p>735 i, iL (E32) 07/1986 → 01/1989</p>	<p>ES⊕ 444.460 incl. 750.492 11 12 9 059 238</p> <p>ES⊕ 764.907 11 12 9 059 238</p> <p>CS* 764.915 11 11 9 059 234</p>	<p>749.370 11 12 1 730 226 1,72 mm $\frac{1}{16}$ 93,5 Ø</p> <p>750.492 11 12 1 730 227 2,07 mm $\frac{1}{16}$ 93,5 Ø</p>  	<p>ZKS 802.700 11 12 0 621 144 (14x) M 12x1,75x157</p> 	<p>774.715 11 12 1 730 231</p> 
<p>M30 B35 (346EC)/(356EA)/ (L-Jetronic,10:1) 6 Cyl. 3453 ccm Cyl. 93,4 Ø</p> <p>635 CSi (E24) 06/1978 → 04/1982</p> <p>735 i (E23) 09/1979 → 09/1982</p> <p>M 535 i (E12) 04/1980 → 05/1981</p>	<p>CS* 888.389 11 11 1 735 046</p>		<p>ZKS 802.700 11 12 0 621 144 (14x) M 12x1,75x157</p> 	<p>774.715 11 12 1 730 231</p> 

			<p>a) </p> <p>b) </p>	<p>K: </p> <p>N: </p>	
<p>VAS 774.456 11 34 9 059 170 2x</p> <p>553.190 11 34 1 273 501 FPM 12x</p>	<p>762.199 11 62 1 723 656 2x</p> 	<p>774.677 11 61 1 726 016 6x</p> 	<p>a) 892.122 11 13 1 722 744</p>  <p>b) 774.390 11 13 1 273 093 M 12x1,5x18</p> <p>b) 110.906 07 11 9 963 151 CU A 12x17x1,5</p> <p>b) 238.708 07 11 9 963 130 AL A 12x15,5x1,5</p>	<p>K:← 586.641 11 14 1 715 101 AW/BS RD FPM 42x62x12</p> <p>K:→ 301.870 11 14 2 249 533 A/BS LD PTFE/FPM 90x110x12</p> <p>K:→ 702.994 11 14 1 706 999 A/BS LD FPM 90x110x12</p>	
<p>VAS 774.456 11 34 9 059 170</p> <p>553.190 11 34 1 273 501 FPM 12x</p>	<p>762.199 11 62 1 723 656 2x</p>  <p>891.991 11 62 1 723 851 6x</p> 	<p>774.669 11 61 1 730 788 6x</p> 	<p>a) 888.354 11 13 1 730 240</p>  <p>b) 774.390 11 13 1 273 093 M 12x1,5x18</p> <p>b) 110.906 07 11 9 963 151 CU A 12x17x1,5</p> <p>b) 238.708 07 11 9 963 130 AL A 12x15,5x1,5</p>	<p>K:← 586.641 11 14 1 715 101 AW/BS RD FPM 42x62x12</p> <p>K:→ 301.870 11 14 2 249 533 A/BS LD PTFE/FPM 90x110x12</p> <p>K:→ 702.994 11 14 1 706 999 A/BS LD FPM 90x110x12</p>	

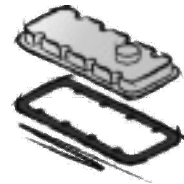
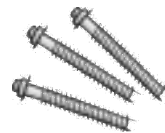
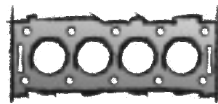
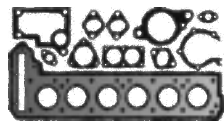







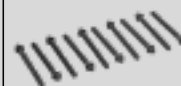
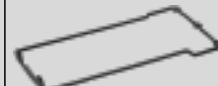



BMW**M62 B35 (358S1)/(358S2)/TU**8 Cyl. **3498 ccm**
Cyl. 84,0 Ø**535 i (E39)**

06/1996 → 06/2003

735 i, iL (E38)

03/1996 → 07/2001

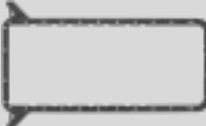
ES⊕ **378.140**
11 12 9 069 055
→09/1998ES⊕ **473.390**
11 12 0 004 553
09/1998→CS* **914.518**
11 11 9 070 240**923.100**
11 12 1 741 463
1,74 mm $\frac{\pm}{\pm}$
L
→09/1997**923.126**
11 12 1 741 466
2,07 mm $\frac{\pm}{\pm}$
L
→09/1997**515.260**
11 12 1 433 467
1,74 mm $\frac{\pm}{\pm}$
L
09/1997→**515.290**
11 12 1 433 468
2,07 mm $\frac{\pm}{\pm}$
L
09/1997→**923.096**
11 12 1 741 461
1,74 mm $\frac{\pm}{\pm}$
R
→09/1997**923.118** ●
11 12 1 741 464
2,07 mm $\frac{\pm}{\pm}$
R
→09/1997**515.250**
11 12 1 433 463
1,74 mm $\frac{\pm}{\pm}$
R
09/1997→**515.270**
11 12 1 433 464
2,07 mm $\frac{\pm}{\pm}$
R
09/1997→**ZKS 802.790**
11 12 1 729 246
M 10x1,5x110
2x**ZKHS 318.620**
11 12 9 069 872
+11 12 1 437 395 (16x)
L
→09/1998**ZKHS 318.640**
11 12 0 034 105
+11 12 1 437 395 (16x)
L
10/1998→**ZKHS 318.610**
11 12 9 069 871
+11 12 1 437 395 (16x)
R
→09/1998**ZKHS 318.630**
11 12 0 034 104
+11 12 1 437 395 (16x)
R
10/1998→**830.305**
11 12 1 747 022
L
→09/1998**830.313**
11 12 1 747 021
R
→09/1998**830.283**
11 12 1 733 969
↑
2x**436.010**
11 12 1 437 395
16x

			<p>a) </p> <p>b) </p>	<p>K: </p> <p>N: </p>	
<p>VAS 424.800 FPM 2x</p> <p>403.730 11 34 2 245 151 FPM 32x</p>	<p>638.181 11 62 7 505 789 3x</p>  <p>638.191 11 62 7 509 677 1x</p> 	<p>266.250 11 61 1 433 328 4x</p> 	<p>a) 803.780 11 13 1 742 109</p>  <p>a) 634.450 11 13 1 436 324</p>  <p>b) 110.906 07 11 9 963 151 CU A 12x17x1,5</p>	<p>K:← 586.676 11 14 1 275 466 A/BS RD FPM 48x65x10</p> <p>K:→ 818.399 11 14 1 713 730 A/BS LD FPM 100x125x13</p>	

BMW

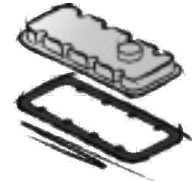
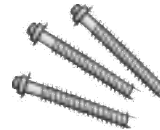
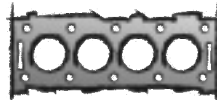
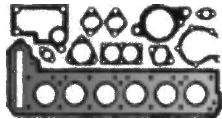

N62 B36 A

8 Cyl. **3600 ccm**
Cyl. 84,0 Ø

735 i / Li (E65/E66)
11/2001 → 02/2005

ES⊕ **734.790**
11 12 7 518 017
+11 61 7 521 181



CS* **373.100**
11 11 7 551 866

745.190
11 12 7 514 378
0,75 mm $\frac{\pm}{\pm}$
2x



191.530
11 12 7 514 379
1,05 mm $\frac{\pm}{\pm}$
2x



ZKS **714.750**
11 12 7 583 113
M 10x1,5x160
2x



ZKHS **632.070**
11 12 7 513 194
+11 12 7 513 195



ZKHS **725.340**
11 12 7 513 195
L



ZKHS **725.330**
11 12 7 513 194
R



M60 B40 (408S1)

8 Cyl. **3982 ccm**
Cyl. 89,0 Ø

540 i (E34)
09/1992 → 07/1996

740 i, iL (E32)
05/1992 → 03/1994

740 i, iL (E38)
03/1994 → 02/1996

840 i (E31)
03/1993 → 02/1996

ES⊕ **914.500**
11 12 1 736 906



CS* **914.518**
11 11 9 070 240

914.533
11 12 1 736 318
1,74 mm $\frac{\pm}{\pm}$ 90 Ø
L



914.525 ●
11 12 1 736 317
1,74 mm $\frac{\pm}{\pm}$ 90 Ø
R

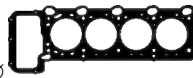

ZKS **802.790**
11 12 1 729 246
M 10x1,5x110
2x

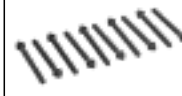

ZKHS **318.620**
11 12 9 069 872
+11 12 1 437 395 (16x)
L



ZKHS **318.610**
11 12 9 069 871
+11 12 1 437 395 (16x)
R



830.305
11 12 1 747 022
L





















830.313
11 12 1 747 021
R



830.283
11 12 1 733 969
↑
2x



			<p>a) </p> <p>b) </p>	<p>K: </p> <p>N: </p>	
<p>VAS 199.440 11 34 0 029 751 FPM 2x</p> <p>198.770 11 34 7 505 417 FPM 32x</p>	<p>638.181 11 62 7 505 789 4x</p>  <p>559.040 11 62 7 505 788 →10/2003 1x</p> 	<p>572.310 11 61 7 521 181 2x</p> 	<p>a) 272.520 11 13 7 545 293 ↑</p>  <p>a) 359.220 11 13 7 506 774</p>  <p>b) 877.870 07 11 9 905 428 +07 11 9 963 308 M 18x1,5x12</p> <p>b) 122.505 07 11 9 963 308 CU A 18x22x1,5</p>	<p>K:← 359.260 11 14 7 647 380 ASW RD PTFE/ACM 45x75x11</p> <p>K:→ 359.180 11 14 7 512 101 SP LD PTFE 100</p>	
<p>VAS 424.800 FPM 2x</p> <p>403.730 11 34 2 245 151 FPM 32x</p>	<p>638.181 11 62 7 505 789 3x</p>  <p>638.191 11 62 7 509 677 1x</p> 	<p>266.250 11 61 1 433 328 4x</p> 	<p>a) 803.780 11 13 1 742 109</p>  <p>a) 634.450 11 13 1 436 324</p>  <p>b) 774.390 11 13 1 273 093 M 12x1,5x18</p> <p>b) 110.906 07 11 9 963 151 CU A 12x17x1,5</p> <p>b) 238.708 07 11 9 963 130 AL A 12x15,5x1,5</p>	<p>K:← 586.676 11 14 1 275 466 A/BS RD FPM 48x65x10</p> <p>K:→ 818.399 11 14 1 713 730 A/BS LD FPM 100x125x13</p>	

BMW

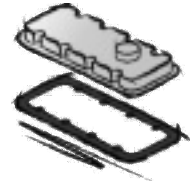

N63 B40 A

8 Cyl. **3982 ccm**
Cyl. 89,0 Ø

- 550 i (F07/10/11/18)**
07/2012 → 02/2017
- 650 i (F06/12/13)**
07/2012 → 10/2018
- 750 i (F01-F04)**
07/2013 → 06/2015
- X5 50 i (F15/85)**
08/2013 → 07/2018
- X6 50 i (F16/86)**
08/2014 → 07/2019

ES⊕ **797.750**
11 12 2 327 854



217.580
11 12 7 567 765
0,75 mm $\frac{\pm}{\pm}$
2x



596.470
11 12 7 567 764
1,05 mm $\frac{\pm}{\pm}$
2x



ZKS **249.210**
11 12 7 607 557
M 11x1,5x175
2x



ZKHS **794.870**
11 12 7 614 701
L



ZKHS **794.880**
11 12 7 614 700
R





S65 B40 A

8 Cyl. **3999 ccm**
Cyl. 92,0 Ø

- M3 (E90/91/92/93)**
06/2007 → 10/2013

ES⊕ **752.131**
11 12 0 429 838





















CS* **736.480**
11 11 0 429 839

198.624
11 12 7 841 560
0,60 mm $\frac{\pm}{\pm}$ 92,8 Ø

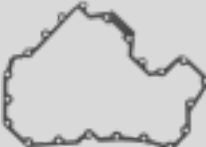

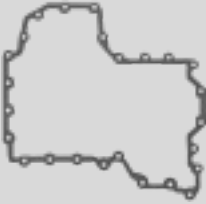
ZKS **460.030**
11 12 7 838 831
M 10x1,5x115
2x

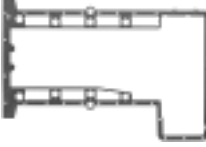

			<p>a) </p> <p>b) </p>	<p>K: </p> <p>N: </p>	
<p>VAS 199.440 11 34 0 029 751 FPM 2x</p> <p>198.770 11 34 7 505 417 FPM 32x</p>	<p>135.600 11 62 7 614 095 2x</p> 		<p>a) 369.733 11 13 7 566 644 ↑</p>  <p>a) 369.710 11 13 7 570 705 F06/12/13 F01-04/07</p>  <p>a) 369.720 11 13 7 570 706 F06/12/13 F01-04/07</p>  <p>a) 369.760 11 13 7 566 808 F15/16</p>  <p>b) 877.870 07 11 9 905 428 +07 11 9 963 308 M 18x1,5x12</p> <p>b) 122.505 07 11 9 963 308 CU A 18x22x1,5</p>	<p>K:← 359.260 11 14 7 647 380 ASW RD PTFE/ACM 45x75x11</p>	
<p>476.691 11 34 1 340 849 FPM 32x</p>	<p>728.600 11 62 7 841 114 4x</p>  <p>728.610 11 62 7 841 115 4x</p> 	<p>752.060 13 54 7 838 297 8x</p> 	<p>a) 354.721 11 13 7 841 085</p>  <p>b) 774.480 07 11 9 919 113 M 12x1,5x12</p> <p>b) 110.906 07 11 9 963 151 CU A 12x17x1,5</p>	<p>K:← 735.260 11 21 7 838 072 AW/BS OF RD FPM 48x65x10</p> <p>K:→ 735.250 11 21 7 838 071 AW/BS OF LD FPM 100x125x12</p>	

BMW



N62 B40 A

8 Cyl. **4000 ccm**
Cyl. 87,0 Ø

- 540 i (E60/E61)**
09/2005 → 12/2009
- 735 i (E65/E66)**
03/2005 → 12/2009
- 740 i (E65/E66)**
03/2005 → 08/2008

ES⊕ **734.720**
11 12 7 551 822
740 i E65/66
540 i E60



ES⊕ **734.790**
11 12 7 518 017
+11 61 7 521 181
735 i E65/66



CS* **373.100**
11 11 7 551 866

735.280
11 12 7 531 863
0,75 mm ±
2x

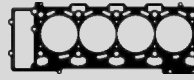

191.440
11 12 7 531 861
1,05 mm ±
2x



ZKS 714.750
11 12 7 583 113
M 10x1,5x160
2x



ZKHS 632.070
11 12 7 513 194
+11 12 7 513 195















ZKHS 725.340
11 12 7 513 195
L



ZKHS 725.330
11 12 7 513 194
R

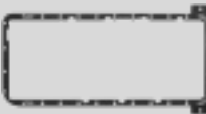

			<p>a) </p> <p>b) </p>	<p>K: </p> <p>N: </p>	
<p>VAS 199.440 11 34 0 029 751 FPM 2x</p> <p>198.770 11 34 7 505 417 FPM 32x</p>	<p>638.181 11 62 7 505 789 4x</p> 	<p>542.430 11 61 7 537 999 8x</p>  <p>572.310 11 61 7 521 181 2x</p> 	<p>a) 272.520 11 13 7 545 293 ↑</p>  <p>a) 359.220 11 13 7 506 774</p>  <p>b) 877.870 07 11 9 905 428 +07 11 9 963 308 M 18x1,5x12</p> <p>b) 122.505 07 11 9 963 308 CU A 18x22x1,5</p>	<p>K:← 359.260 11 14 7 647 380 ASW RD PTFE/ACM 45x75x11</p> <p>K:→ 359.180 11 14 7 512 101 SP LD PTFE 100</p>	

BMW

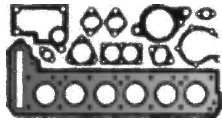

N63 B44 A

8 Cyl. **4395 ccm**
Cyl. 89,0 Ø

- 550 i (F07/10/11/18)**
08/2009 → 02/2017
- 650 i (F06/12/13)**
12/2010 → 06/2018
- 750 i (F01-F04)**
09/2008 → 06/2012
- ActiveHybrid (E71/72)**
01/2009 → 10/2011
- ActiveHybrid (F01-F04)**
04/2010 → 06/2012
- X5 50 i (E70)**
09/2009 → 07/2013
- X6 50 i (E71/72)**
10/2007 → 07/2014

ES⊕ **029.350**
11 12 7 583 203



CS* **284.470**
11 11 2 159 389

CS* **593.960**
11 11 2 158 085
X6 E71/E72
X5 E70

217.580
11 12 7 567 765
0,75 mm ±
2x



596.470
11 12 7 567 764
1,05 mm ±
2x



ZKS 249.200
11 12 7 582 454
M 11x1,5x175
→11/2011
2x



ZKS 249.210
11 12 7 607 557
M 11x1,5x175
11/2011→
2x



ZKHS 008.560
11 12 7 566 290
11 12 7 566 289
11 12 7 566 288



451.740
11 12 7 566 289
L



























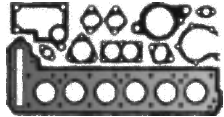
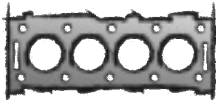

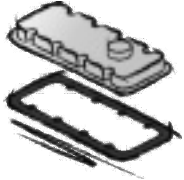
451.680
11 12 7 566 288
R

















451.750
11 12 7 566 290
↑
2x



			<p>a) </p> <p>b) </p>	<p>K: </p> <p>N: </p>	
<p>VAS 199.440 11 34 0 029 751 FPM 2x</p> <p>198.770 11 34 7 505 417 FPM 32x</p>	<p>135.600 11 62 7 614 095 2x</p> 		<p>a) 369.733 11 13 7 566 644 ↑</p>  <p>a) 369.710 11 13 7 570 705 F01-04/07 F10/11/12/13</p>  <p>a) 369.720 11 13 7 570 706 F10/11/12/13 F01-04/07</p>  <p>a) 369.760 11 13 7 566 808 X6 E71/E72 X5 E70</p>  <p>b) 877.870 07 11 9 905 428 +07 11 9 963 308 M 18x1,5x12</p> <p>b) 122.505 07 11 9 963 308 CU A 18x22x1,5</p>	<p>K:← 359.260 11 14 7 647 380 ASW RD PTFE/ACM 45x75x11</p> <p>K:← 656.160 11 14 7 558 914 SP RD PTFE/ACM 45x75x13,5 X6 E71/E72 X5 E70</p> <p>K:→ 284.460 11 14 7 583 221 LD PTFE/ACM 100</p> <p>K:→ 484.730 SP LD PTFE/ACM 100x120x10 7 F04 Hybrid</p>	

BMW 				
N63 B44 B 8 Cyl. 4395 ccm Cyl. 89,0 Ø 550 i (F07/10/11/18) 07/2012 → 02/2017 650 i (F06/12/13) 07/2012 → 10/2018 750 i (F01-F04) 09/2008 → 08/2015 X5 50 i (F15/85) 08/2013 → 07/2018 X6 50 i (F16/86) 08/2014 → 07/2019	ES⊕ 797.750 11 12 2 327 854  CS* 284.470 11 11 2 159 389	217.580 11 12 7 567 765 0,75 mm $\frac{\pm}{\text{mm}}$ 2x  596.470 11 12 7 567 764 1,05 mm $\frac{\pm}{\text{mm}}$ 2x 	ZKS 249.200 11 12 7 582 454 M 11x1,5x175 →11/2011 2x  ZKS 249.210 11 12 7 607 557 M 11x1,5x175 11/2011→ 2x 	ZKHS 794.870 11 12 7 614 701 L  ZKHS 794.880 11 12 7 614 700 R 
N63 B44 C 8 Cyl. 4395 ccm Cyl. 89,0 Ø 750 i (G11/12) 09/2015 → 02/2019 M 550 i (G30/31) 03/2017 → 06/2019	ES⊕ 692.530  CS* 485.200		ZKS 249.210 11 12 7 607 557 M 11x1,5x175 2x 	ZKHS 795.120 11 12 8 636 547 L ZKHS 795.130 11 12 8 636 546 R

			<p>a) </p> <p>b) </p>	<p>K: </p> <p>N: </p>	
<p>VAS 199.440 11 34 0 029 751 FPM 2x</p> <p>198.770 11 34 7 505 417 FPM 32x</p>	<p>135.600 11 62 7 614 095 2x</p> 		<p>a) 369.733 11 13 7 566 644 ↑</p>  <p>a) 369.710 11 13 7 570 705</p>  <p>a) 369.720 11 13 7 570 706</p>  <p>b) 877.870 07 11 9 905 428 +07 11 9 963 308 M 18x1,5x12</p> <p>b) 122.505 07 11 9 963 308 CU A 18x22x1,5</p>	<p>K:← 359.260 11 14 7 647 380 ASW RD PTFE/ACM 45x75x11 7 F01/02/03/04 5 F07/10/11 6 F06/12/13</p> <p>K:← 656.160 11 14 7 558 914 SP RD PTFE/ACM 45x75x13,5 X5, X6 F85/86</p> <p>K:→ 284.460 11 14 7 583 221 LD PTFE/ACM 100</p>	
<p>VAS 199.440 11 34 0 029 751 FPM 2x</p> <p>198.770 11 34 7 505 417 FPM 32x</p>	<p>135.600 11 62 7 614 095 2x</p> 	<p>648.280 11 61 8 610 666 2x</p> 	<p>a) 299.510 11 13 8 601 057 ↑</p> <p>a) 303.171 11 13 8 601 061</p> <p>a) 303.180 11 13 8 601 065</p> <p>b) 247.405 07 11 9 963 300 AL A 18x22x1,5</p>	<p>K:← 359.260 11 14 7 647 380 ASW RD PTFE/ACM 45x75x11</p> <p>K:→ 284.460 11 14 7 583 221 LD PTFE/ACM 100</p>	

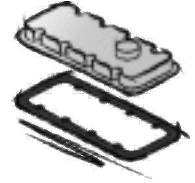
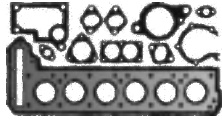
BMW**N63 B44 D**

8 Cyl. **4395 ccm**
Cyl. 89,0 Ø

750 i (G11/12)

03/2019 →

M 550 i (G30/31)

07/2019 →

M 850 i (G14)

11/2018 →

M 850 i (G15)

10/2018 →

M 850 i (G16)

07/2019 →

X5 50 i (G05)

08/2018 →

X5 M50 i (G05)

08/2019 →

X6 M50 i (G06)

08/2019 →

X7 50 i (G07)

03/2019 →

X7 M50 i (G07)

07/2019 →

ZKS 249.210

11 12 7 607 557

M 11x1,5x175

2x

**ZKHS 795.120**

11 12 8 636 547

L

ZKHS 795.130

11 12 8 636 546

R

S63 B44 A

8 Cyl. **4395 ccm**
Cyl. 89,0 Ø

X5 M (E70)

07/2009 → 07/2013

X6 M (E71/72)

07/2008 → 07/2014

ES⊕

648.560

11 12 2 159 374



CS*

593.960

11 11 2 158 085

217.580

11 12 7 567 765

0,75 mm $\frac{\pm}{\mp}$

2x

**596.470**

11 12 7 567 764

1,05 mm $\frac{\pm}{\mp}$

2x

**ZKS 249.200**

11 12 7 582 454

M 11x1,5x175

→11/2011

2x

**ZKS 249.210**

11 12 7 607 557

M 11x1,5x175

11/2011→

2x

**ZKHS 008.560**

11 12 7 566 290

11 12 7 566 289

11 12 7 566 288

**451.740**

11 12 7 566 289

L

**451.680**

11 12 7 566 288

R













**451.750**

11 12 7 566 290

↑

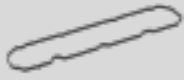
2x



			<p>a) </p> <p>b) </p>	<p>K: </p> <p>N: </p>	
<p>VAS 199.440 11 34 0 029 751 FPM 2x</p> <p>198.770 11 34 7 505 417 FPM 32x</p>		<p>648.280 11 61 8 610 666 2x</p> 	<p>a) 299.510 11 13 8 601 057 ↑</p> <p>a) 303.180 11 13 8 601 065</p> <p>b) 247.405 07 11 9 963 300 AL A 18x22x1,5</p>	<p>K:← 656.160 11 14 7 558 914 SP RD PTFE/ACM 45x75x13,5</p>	
<p>VAS 199.440 11 34 0 029 751 FPM 2x</p> <p>198.770 11 34 7 505 417 FPM 32x</p>	<p>541.172 11 62 7 589 106 2x</p> 		<p>a) 369.733 11 13 7 566 644 ↑</p>  <p>a) 369.760 11 13 7 566 808</p>  <p>b) 877.870 07 11 9 905 428 +07 11 9 963 308 M 18x1,5x12</p> <p>b) 122.505 07 11 9 963 308 CU A 18x22x1,5</p>	<p>K:← 656.160 11 14 7 558 914 SP RD PTFE/ACM 45x75x13,5</p> <p>K:→ 284.460 11 14 7 583 221 LD PTFE/ACM 100</p>	

BMW

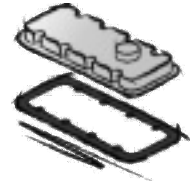
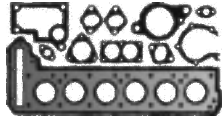

S63 B44 B

8 Cyl. 4395 ccm
Cyl. 89,0 ∅

M5 (F10/11/18)

09/2011 → 10/2016

M5 (G30/31)

09/2017 →

M5 CS (G30/31)

03/2021 →

M6 (F06/12/13)

03/2012 → 10/2018

M8 (G14)

07/2019 →

X5 M (F15/85)

12/2014 → 07/2018

X5 M (G05)

12/2019 →

X6 M (F16/86)

12/2014 → 07/2019

X6 M (G06)

12/2019 →

ES⊕ **797.750**
11 12 2 327 854
F06/12/13
F85/86



CS* **648.590**
11 11 2 250 202
G14/15/16
G30
F10
F06/12/13

034.550
0,75 mm \pm 89 ∅
6 F06/12/13
5 F10/11
2x

217.580
11 12 7 567 765
0,75 mm \pm
2x



ZKS **249.210**
11 12 7 607 557
M 11x1,5x175
2x















ZKHS **794.870**
11 12 7 614 701
L
F06/12/13
F85/86



ZKHS **794.880**
11 12 7 614 700
R
F06/12/13
F85/86

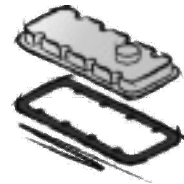
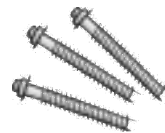
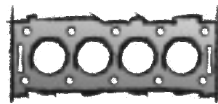
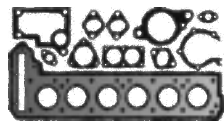

			<p>a) </p> <p>b) </p>	<p>K: </p> <p>N: </p>	
<p>VAS 199.440 11 34 0 029 751 FPM 2x</p> <p>198.770 11 34 7 505 417 FPM 32x</p>	<p>541.172 11 62 7 589 106 2x</p> 		<p>a) 369.733 11 13 7 566 644 ↑ F15/16</p>  <p>a) 631.590 11 13 7 852 273 ↑ F90/91/92/93</p> <p>a) 691.403 11 13 7 843 145 ↑ G30 G14/15/16 F10 F06/12/13</p>  <p>a) 631.580 11 13 7 852 272 F90/91/92/93</p> <p>a) 369.760 11 13 7 566 808 F15/16</p>  <p>a) 691.390 11 13 7 843 149 F10 F06/12/13 G30 G14/15/16</p>  <p>b) 877.870 07 11 9 905 428 +07 11 9 963 308 M 18x1,5x12</p> <p>b) 110.906 07 11 9 963 151 CU A 12x17x1,5</p> <p>b) 122.505 07 11 9 963 308 CU A 18x22x1,5</p>	<p>K:← 359.260 11 14 7 647 380 ASW RD PTFE/ACM 45x75x11 5 F10/11 6 F06/12/13</p> <p>K:← 656.160 11 14 7 558 914 SP RD PTFE/ACM 45x75x13,5 X5, X6 F85/86</p> <p>K:→ 284.460 11 14 7 583 221 LD PTFE/ACM 100</p>	

BMW**M62 B44 (448S1)**

8 Cyl. **4398 ccm**
Cyl. 92,0 Ø

540 i (E39)

03/1996 → 12/2003

740 i, iL (E38)

02/1996 → 07/2001

840 Ci (E31)

03/1996 → 06/1999

ES⊕ **378.140**
11 12 9 069 055
→09/1998



ES⊕ **473.390**
11 12 0 004 553
09/1998→



CS* **914.518**
11 11 9 070 240

268.041
11 12 1 741 471
1,74 mm $\frac{\pm}{\text{L}}$
→09/1997



268.050
11 12 1 433 477
1,74 mm $\frac{\pm}{\text{L}}$
09/1997→



268.160
11 12 1 433 478
2,04 mm $\frac{\pm}{\text{L}}$
09/1997→



268.170
11 12 1 741 468
1,74 mm $\frac{\pm}{\text{R}}$
→09/1997



268.180
11 12 1 433 473
1,74 mm $\frac{\pm}{\text{R}}$
09/1997→

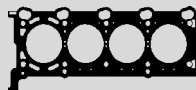

268.190
11 12 1 433 474
2,04 mm $\frac{\pm}{\text{R}}$
09/1997→



ZKS **802.790**
11 12 1 729 246
M 10x1,5x110
2x

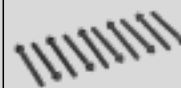

ZKHS **318.620**
11 12 9 069 872
+11 12 1 437 395 (16x)
L
→09/1998



ZKHS **318.640**
11 12 0 034 105
+11 12 1 437 395 (16x)
L
10/1998→



ZKHS **318.610**
11 12 9 069 871
+11 12 1 437 395 (16x)
R
→09/1998



ZKHS **318.630**
11 12 0 034 104
+11 12 1 437 395 (16x)
R
10/1998→



830.305
11 12 1 747 022
L
→09/1998



830.313
11 12 1 747 021
R
→09/1998

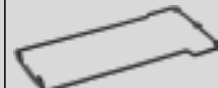













830.283
11 12 1 733 969
↑
2x



436.010
11 12 1 437 395
16x

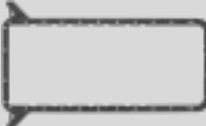

			<p>a) </p> <p>b) </p>	<p>K: </p> <p>N: </p>	
<p>VAS 424.800 FPM 2x</p> <p>403.730 11 34 2 245 151 FPM 32x</p>	<p>638.181 11 62 7 505 789 3x</p>  <p>638.191 11 62 7 509 677 1x</p> 	<p>266.250 11 61 1 433 328 4x</p> 	<p>a) 803.780 11 13 1 742 109</p>  <p>a) 634.450 11 13 1 436 324</p>  <p>b) 110.906 07 11 9 963 151 CU A 12x17x1,5</p>	<p>K:← 586.676 11 14 1 275 466 A/BS RD FPM 48x65x10</p> <p>K:→ 818.399 11 14 1 713 730 A/BS LD FPM 100x125x13</p>	

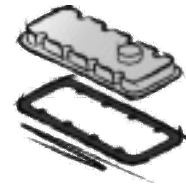
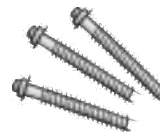
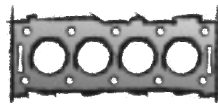
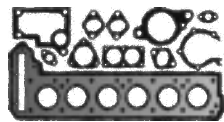
BMW**M62 B44 (448S2)**

8 Cyl. **4398 ccm**
Cyl. 92,0 Ø

540 i (E39)

03/1996 → 12/2003

740 i, iL (E38)

02/1996 → 07/2001

X5 4.4 i (E53)

01/2000 → 09/2003

ES⊕ **378.140**
11 12 9 069 055
→09/1998



ES⊕ **473.390**
11 12 0 004 553
09/1998→



CS* **914.518**
11 11 9 070 240

268.041
11 12 1 741 471
1,74 mm $\frac{\pm}{\pm}$
L
→09/1997



268.050
11 12 1 433 477
1,74 mm $\frac{\pm}{\pm}$
L
09/1997→



268.160
11 12 1 433 478
2,04 mm $\frac{\pm}{\pm}$
L
09/1997→



268.170
11 12 1 741 468
1,74 mm $\frac{\pm}{\pm}$
R
→09/1997



268.180
11 12 1 433 473
1,74 mm $\frac{\pm}{\pm}$
R
09/1997→



268.190
11 12 1 433 474
2,04 mm $\frac{\pm}{\pm}$
R
09/1997→



ZKS **802.790**
11 12 1 729 246
M 10x1,5x110
2x

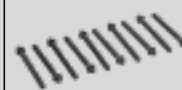

ZKHS **318.620**
11 12 9 069 872
+11 12 1 437 395 (16x)
L
→09/1998



ZKHS **318.640**
11 12 0 034 105
+11 12 1 437 395 (16x)
L
10/1998→



ZKHS **318.610**
11 12 9 069 871
+11 12 1 437 395 (16x)
R
→09/1998



ZKHS **318.630**
11 12 0 034 104
+11 12 1 437 395 (16x)
R
10/1998→



830.305
11 12 1 747 022
L
→09/1998



830.313
11 12 1 747 021
R
→09/1998

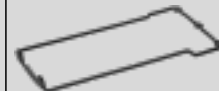















830.283
11 12 1 733 969
↑
2x



436.010
11 12 1 437 395
16x

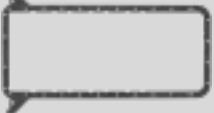

			<p>a) </p> <p>b) </p>	<p>K: </p> <p>N: </p>	
<p>VAS 424.800 FPM 2x</p> <p>403.730 11 34 2 245 151 FPM 32x</p>	<p>638.181 11 62 7 505 789 3x</p>  <p>638.191 11 62 7 509 677 1x</p> 	<p>266.250 11 61 1 433 328 4x</p> 	<p>a) 359.590 11 13 7 500 260 X5 E53</p>  <p>a) 803.780 11 13 1 742 109</p>  <p>a) 361.023 11 13 7 500 261 X5 E53</p>  <p>a) 634.450 11 13 1 436 324</p>  <p>b) 110.906 07 11 9 963 151 CU A 12x17x1,5</p>	<p>K:← 586.676 11 14 1 275 466 A/BS RD FPM 48x65x10</p> <p>K:→ 818.399 11 14 1 713 730 A/BS LD FPM 100x125x13</p>	

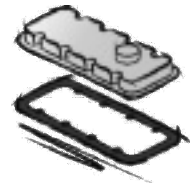
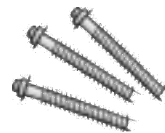
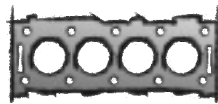
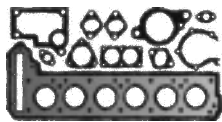
BMW**N62 B44 A**

8 Cyl. **4398 ccm**
Cyl. 92,0 Ø

545 i (E60/61)
09/2003 → 12/2010
645 Ci (E63/64)
09/2003 → 12/2005
745 i /Li (E65/E66)
07/2001 → 12/2005
X5 4.4 i (E53)
10/2003 → 10/2006

ES⊕ **734.790**
11 12 7 518 017
+11 61 7 521 181



CS* **373.100**
11 11 7 551 866
6 E63/64
7 E65/66/67
5 E60/61

CS* **897.290**
11 11 0 304 864
X5 E53

655.570
11 12 7 513 944
0,75 mm \pm
2x



743.220
11 12 7 513 945
1,05 mm \pm
2x



ZKS **714.750**
11 12 7 583 113
M 10x1,5x160
2x



ZKHS **632.070**
11 12 7 513 194
+11 12 7 513 195



ZKHS **725.340**
11 12 7 513 195
L



ZKHS **725.330**
11 12 7 513 194
R

**M62 B46 (468S1)**

8 Cyl. **4619 ccm**
Cyl. 93,0 Ø

X5 4.6 i (E53)
10/2001 → 09/2003

ES⊕ **473.390**
11 12 0 004 553



659.120
11 12 7 519 410
L Cyl. 5-8



659.110
11 12 7 519 406
R Cyl. 1-4



ZKS **802.790**
11 12 1 729 246
M 10x1,5x110
2x

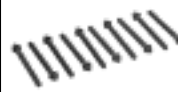

ZKHS **318.640**
11 12 0 034 105
+11 12 1 437 395 (16x)
L



















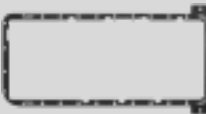

ZKHS **318.630**
11 12 0 034 104
+11 12 1 437 395 (16x)
R



436.010
11 12 1 437 395
16x

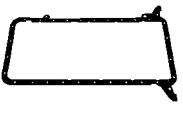

			<p>a) </p> <p>b) </p>	<p>K: </p> <p>N: </p>	
<p>VAS 199.440 11 34 0 029 751 FPM 2x</p> <p>198.770 11 34 7 505 417 FPM 32x</p>	<p>638.181 11 62 7 505 789 4x</p> 	<p>572.310 11 61 7 521 181 2x</p> 	<p>a) 272.520 11 13 7 545 293 ↑</p>  <p>a) 100.141 11 13 7 539 582 X5 E53</p>  <p>a) 359.220 11 13 7 506 774 7 E65/66/67 6 E63/64 5 E60/61</p>  <p>b) 877.870 07 11 9 905 428 +07 11 9 963 308 M 18x1,5x12</p> <p>b) 122.505 07 11 9 963 308 CU A 18x22x1,5</p>	<p>K:← 359.260 11 14 7 647 380 ASW RD PTFE/ACM 45x75x11</p> <p>K:← 656.160 11 14 7 558 914 SP RD PTFE/ACM 45x75x13,5 X5 E53</p> <p>K:→ 359.180 11 14 7 512 101 SP LD PTFE 100</p>	
<p>VAS 424.800 FPM 2x</p> <p>403.730 11 34 2 245 151 FPM 32x</p>	<p>638.181 11 62 7 505 789 3x</p>  <p>638.191 11 62 7 509 677 1x</p> 	<p>266.250 11 61 1 433 328 4x</p> 	<p>a) 359.590 11 13 7 500 260</p>  <p>a) 361.023 11 13 7 500 261</p>  <p>b) 110.906 07 11 9 963 151 CU A 12x17x1,5</p>	<p>K:← 586.676 11 14 1 275 466 A/BS RD FPM 48x65x10</p> <p>K:→ 818.399 11 14 1 713 730 A/BS LD FPM 100x125x13</p>	

BMW

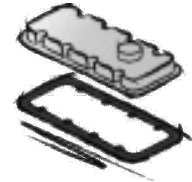
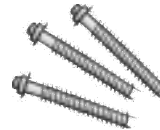
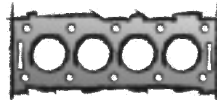
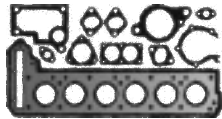

N62 B48 A

8 Cyl. 4799 ccm
Cyl. 93,0 Ø

550 i (E60/61)
07/2005 → 12/2010
X5 4.8 i (E53)
04/2004 → 09/2006

ES⊕ **734.720**
11 12 7 551 822
6 E63/64
5 E60/61



ES⊕ **902.150**
11 12 0 306 824
+11 61 7 521 181 (2x)
X5 E53



CS* **373.100**
11 11 7 551 866
5 E60/61
6 E63/64

CS* **897.290**
11 11 0 304 864
X5 E53

736.220
11 12 7 530 256
0,75 mm ±
2x



191.450
11 12 7 530 257
1,05 mm ±
2x



ZKS **714.750**
11 12 7 583 113
M 10x1,5x160
2x



ZKHS **632.070**
11 12 7 513 194
+11 12 7 513 195



ZKHS **725.340**
11 12 7 513 195
L



ZKHS **725.330**
11 12 7 513 194
R



N62 B48 B

8 Cyl. 4799 ccm
Cyl. 93,0 Ø

550 i (E60/61)
07/2005 → 12/2010
650 i (E63/64)
09/2005 → 08/2010
750 i /Li (E65/E66)
03/2005 → 08/2008
X5 48 i (E70)
10/2006 → 03/2010

ES⊕ **734.720**
11 12 7 551 822



CS* **373.100**
11 11 7 551 866

736.220
11 12 7 530 256
0,75 mm ±
2x

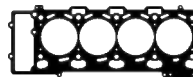

191.450
11 12 7 530 257
1,05 mm ±
2x

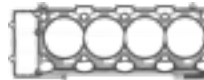

ZKS **714.750**
11 12 7 583 113
M 10x1,5x160
2x



ZKHS **632.070**
11 12 7 513 194
+11 12 7 513 195























ZKHS **725.340**
11 12 7 513 195
L



ZKHS **725.330**
11 12 7 513 194
R



			<p>a) </p> <p>b) </p>	<p>K: </p> <p>N: </p>	
<p>VAS 199.440 11 34 0 029 751 FPM 2x</p> <p>198.770 11 34 7 505 417 FPM 32x</p>	<p>559.040 11 62 7 505 788 5 E60/61 6 E63/64 1x</p>  <p>638.181 11 62 7 505 789 3x</p> <hr/> <p>4x</p>  <p>638.191 11 62 7 509 677 X5 E53 1x</p> 	<p>542.430 11 61 7 537 999 6 E63/64 5 E60/61 8x</p>  <p>572.310 11 61 7 521 181 X5 E53 2x</p> 	<p>a) 272.520 11 13 7 545 293 ↑</p>  <p>a) 100.141 11 13 7 539 582 X5 E53</p>  <p>a) 359.220 11 13 7 506 774 5 E60/61 6 E63/64</p>  <p>b) 877.870 07 11 9 905 428 +07 11 9 963 308 M 18x1,5x12</p> <p>b) 122.505 07 11 9 963 308 CU A 18x22x1,5</p>	<p>K:← 359.260 11 14 7 647 380 ASW RD PTFE/ACM 45x75x11</p> <p>K:← 656.160 11 14 7 558 914 SP RD PTFE/ACM 45x75x13,5 X5 E53</p> <p>K:→ 359.180 11 14 7 512 101 SP LD PTFE 100</p>	
<p>VAS 199.440 11 34 0 029 751 FPM 2x</p> <p>198.770 11 34 7 505 417 FPM 32x</p>	<p>559.040 11 62 7 505 788 1x</p>  <p>638.181 11 62 7 505 789 3x</p> <hr/> <p>X5 E70 4x</p> 	<p>542.430 11 61 7 537 999 8x</p> 	<p>a) 272.520 11 13 7 545 293 ↑</p>  <p>a) 359.220 11 13 7 506 774 7 E65/66/67 6 E63/64 5 E60/61</p>  <p>b) 877.870 07 11 9 905 428 +07 11 9 963 308 M 18x1,5x12</p> <p>b) 122.505 07 11 9 963 308 CU A 18x22x1,5</p>	<p>K:← 359.260 11 14 7 647 380 ASW RD PTFE/ACM 45x75x11</p> <p>K:← 656.160 11 14 7 558 914 SP RD PTFE/ACM 45x75x13,5 X5 E70</p> <p>K:→ 359.180 11 14 7 512 101 SP LD PTFE 100</p>	

BMW

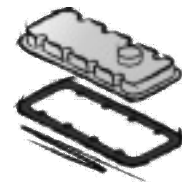
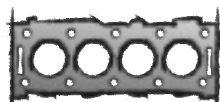
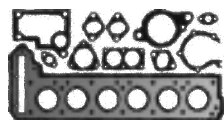

S62 B50 (508S1)

8 Cyl. **4941 ccm**
Cyl. 94,0 Ø

M5 (E39)
10/1998 → 06/2003
Z8 (E52)
01/2000 → 12/2003

496.222

11 12 7 833 734
1,65 mm $\frac{\pm}{\text{L}}$



100.520

11 12 7 833 759
2,00 mm $\frac{\pm}{\text{L}}$



496.212

11 12 7 833 733
1,65 mm $\frac{\pm}{\text{R}}$



100.470

11 12 7 833 758
2,00 mm $\frac{\pm}{\text{R}}$



ZKHS 712.000
11 12 1 406 783
L



ZKHS 711.990
11 12 1 406 782
R



M70 B50 (5012A)

12 Cyl. **4988 ccm**
Cyl. 84,0 Ø

750 i, iL (E32)
09/1987 → 09/1994
850 Ci (E31)
01/1990 → 08/1994

914.452 ●

11 12 1 731 652
1,60 mm $\frac{\pm}{\text{L}}$ 84 Ø



914.460 ●

11 12 1 731 654
2,13 mm $\frac{\pm}{\text{L}}$ 84 Ø



ZKS 802.820
11 12 1 740 065
M 10x1,5x110
2x



818.704 ●
11 12 1 725 002
R



S85 B50 A

10 Cyl. **4999 ccm**
Cyl. 92,0 Ø

M5 (E60/61)
09/2004 → 12/2010
M6 (E63/64)
09/2005 → 08/2010

ES⊕ **740.421**
11 12 0 392 976





















007.961



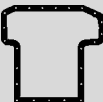





11 12 7 837 460
0,60 mm $\frac{\pm}{\text{L}}$ 92,8 Ø

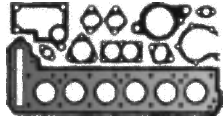
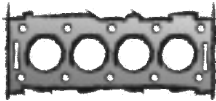

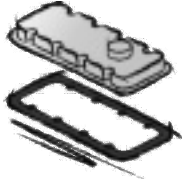











ZKS 460.030
11 12 7 838 831
M 10x1,5x115
2x







			<p>a) </p> <p>b) </p>	<p>K: </p> <p>N: </p>	
<p>VAS 424.800 FPM 2x</p> <p>403.730 11 34 2 245 151 FPM 32x</p>	<p>638.181 11 62 7 505 789 3x</p>  <p>638.191 11 62 7 509 677 1x</p> 		<p>a) 496.242 11 13 7 831 014 ↑</p>  <p>a) 496.251 11 13 1 407 532 M5 E39</p>  <p>a) 612.440 ● 11 13 7 830 598 Z8 E52</p>  <p>b) 878.020 07 11 9 903 199 +07 11 9 963 151 M 12x1,5x12</p> <p>b) 110.906 07 11 9 963 151 CU A 12x17x1,5</p>	<p>K:← 586.676 11 14 1 275 466 A/BS RD FPM 48x65x10</p> <p>K:→ 818.399 11 14 1 713 730 A/BS LD FPM 100x125x13</p>	
<p>VAS 825.050 11 34 9 059 172 FPM 2x</p> <p>701.289 11 34 1 706 707 FPM 24x</p>	<p>599.077 11 62 1 708 966 12x</p> 		<p>a) 817.644 11 13 1 713 703</p>  <p>b) 774.390 11 13 1 273 093 M 12x1,5x18</p> <p>b) 110.906 07 11 9 963 151 CU A 12x17x1,5</p> <p>b) 238.708 07 11 9 963 130 AL A 12x15,5x1,5</p>	<p>K:← 173.890 ASW RD PTFE/ACM 55x72x8</p> <p>K:→ 818.399 11 14 1 713 730 A/BS LD FPM 100x125x13</p> <p>N:← 562.939 11 14 1 707 107 AW RD FPM 28x40x7 2x</p>	
<p>VAS 714.190 11 34 0 032 548 2x</p> <p>476.691 11 34 1 340 849 FPM 40x</p>	<p>698.970 11 62 7 833 278 10x</p> 	<p>727.920 13 54 7 834 023 10x</p> 	<p>a) 000.162 11 13 7 836 361 11</p>  <p>b) 110.906 07 11 9 963 151 CU A 12x17x1,5</p>	<p>K:← 050.260 11 14 2 249 532 AS RD PTFE/ACM 48x65x10</p>	

<p>BMW</p> 				
<p>M73 B54 M73 B54 (54121)/(54122)</p> <p>12 Cyl. 5379 ccm Cyl. 85,0 Ø</p> <p>750 i, iL (E32) 09/1998 → 07/2001</p> <p>750 i, iL (E38) 11/1994 → 07/2001</p> <p>850 Ci (E31) 09/1994 → 12/1999</p>		<p>442.050 11 12 1 702 082 1,75 mm \pm 86 Ø Cyl. 1-6</p> <p>442.180 11 12 1 702 083 1,75 mm \pm 86 Ø Cyl. 7-12</p>  	<p>ZKS 802.820 11 12 1 740 065 M 10x1,5x110 2x</p> 	<p>818.704 ● 11 12 1 725 002 R</p> 
<p>M70 B56 S70 B56 (56121)</p> <p>12 Cyl. 5576 ccm Cyl. 86,0 Ø</p> <p>850 CSi (E31) 11/1992 → 12/1996</p>			<p>ZKS 802.820 11 12 1 740 065 M 10x1,5x110 2x</p> 	<p>818.704 ● 11 12 1 725 002 R</p> 

			<p>a) </p> <p>b) </p>	<p>K: </p> <p>N: </p>	
<p>VAS 825.050 11 34 9 059 172 FPM 2x</p> <p>701.289 11 34 1 706 707 FPM 24x</p>	<p>550.830 11 62 1 704 539 8x</p>  <p>550.840 11 62 1 704 540 4x</p> 		<p>a) 817.644 11 13 1 713 703</p>  <p>b) 877.940 11 13 7 568 309 +07 11 9 963 150 M 12x1,5x10</p> <p>b) 110.906 07 11 9 963 151 CU A 12x17x1,5</p>	<p>K:← 173.890 ASW RD PTFE/ACM 55x72x8</p> <p>K:→ 818.399 11 14 1 713 730 A/BS LD FPM 100x125x13</p> <p>N:← 562.939 11 14 1 707 107 AW RD FPM 28x40x7 2x</p>	
<p>VAS 825.050 11 34 9 059 172 FPM 2x</p> <p>701.289 11 34 1 706 707 FPM 24x</p>	<p>599.077 11 62 1 708 966 12x</p> 		<p>a) 817.644 11 13 1 713 703</p>  <p>b) 774.390 11 13 1 273 093 M 12x1,5x18</p> <p>b) 110.906 07 11 9 963 151 CU A 12x17x1,5</p> <p>b) 238.708 07 11 9 963 130 AL A 12x15,5x1,5</p>	<p>K:← 173.890 ASW RD PTFE/ACM 55x72x8</p> <p>K:→ 818.399 11 14 1 713 730 A/BS LD FPM 100x125x13</p> <p>N:← 562.939 11 14 1 707 107 AW RD FPM 28x40x7 2x</p>	

CHANGAN



CHANGAN		ccm	kW				
Alsvin	4	1499	84	01/2012	12/2014	JL478QCA JL478QCC	570
Benni	4	1301	63	11/2006	12/2010	JL474Q6 JL474Q8	570
CS75	4	1798	130	07/2014		JL486ZQ2	570
CS75	4	1998	116	02/2014		JL486Q5	570
CX30	4	1998	112	05/2010	12/2012	JL486Q1 JL486Q2	570
Jiexun	4	1998	112	01/2006	12/2008	JL486Q1	570
Raeton	4	1798	130	04/2013		JL486ZQ2	570
Raeton	4	1998	116	04/2013		JL486Q5	570
Zhixiang	4	1998	112	11/2008	12/2012	JL486Q1 JL486Q2	570

CHANGAN



CHANGAN











C 20	4	1998	570
JL474Q6	4	1301	570
JL474Q8	4	1301	570
JL478QCA	4	1499	570
JL478QCC	4	1499	570
JL478QCE	4	1499	570
JL486Q	4	1998	570
JL486Q1	4	1998	570
JL486Q2	4	1998	570
JL486Q5	4	1998	570
JL486ZQ2	4	1798	570

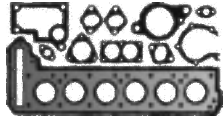
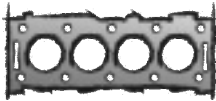

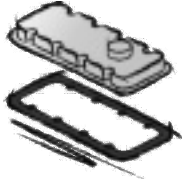

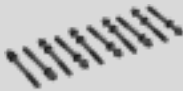

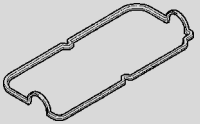
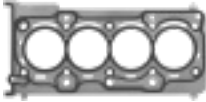
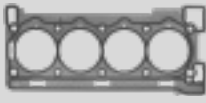



CHANGAN

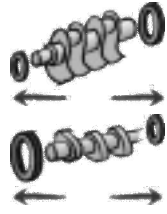

Das Original

CHANGAN 				
JL474Q6/8 4 Cyl. 1301 ccm Cyl. 74,0 Ø Benni 11/2006 → 12/2010	ES⊕ 176.450	176.510 1,50 mm $\frac{\pm}{\pm}$ 75,5 Ø 	ZKS 220.780 M 10x1,5x95 	ZKHS 388.390  026.450 
JL478QCA/QCC/QCE 4 Cyl. 1499 ccm Alsvin 01/2012 → 12/2014		110.300 1003040-B01 0,55 mm $\frac{\pm}{\pm}$ 79 Ø 		
JL486ZQ2 4 Cyl. 1798 ccm Cyl. 86,5 Ø CS75 07/2014 → Raeton 04/2013 →		110.320 1003040-A02 0,68 mm $\frac{\pm}{\pm}$ 87,2 Ø 		
C 20 JL486Q JL486Q1/2/5 4 Cyl. 1998 ccm Cyl. 86,5 Ø CS75 02/2014 → CX30 05/2010 → 12/2012 Jiexun 01/2006 → 12/2008 Raeton 04/2013 → Zhixiang 11/2008 → 12/2012		110.290 1003040-A01 0,60 mm $\frac{\pm}{\pm}$ 87,2 Ø 		

			<p>a) </p> <p>b) </p>	<p>K: </p> <p>N: </p>	
<p>166.190 FPM 16x</p>	<p>176.570 </p>	<p>176.560 </p>	<p>a) 036.164 Dirko HT / EU</p> <p>a) 510.031 Dirko HT / USA/CDN/MEX</p> <p>a) 527.291 Dirko HT / RU</p> <p>a) 648.661 Dirko HT / BR</p>	<p>K:← 166.160 AS RD FPM 32x47x6</p> <p>K:→ 505.293 AS LD FPM 68x86x8</p> <p>N:← 166.160 AS RD FPM 32x47x6</p>	

CHEVROLET/DAEWOO



CHEVROLET/ DAEWOO	ccm	kW	→	→			
Alero	4	2198	104	12/2001	09/2004	L61	616
Aranos	4	1498	66	01/1995	11/1997	V15L	594
Aranos	4	1796	70	01/1995	11/1997	Y18L	604
Aranos	4	1998	77	01/1995	11/1997	C20LE	610
Aranos	4	1998	81	01/1995	11/1997	C20LE	610
Astra	4	1796	81	09/1998	12/2011	C 18 NE LC5(110CUL4)	604
Astra	4	1796	103	01/2006	12/2013	2H0	602
Aveo	4	1150	53	01/2004		LY4	582
Aveo	4	1150	56	01/2007	09/2012	B12S1 LY4	582
Aveo	4	1206	55	01/2008		LMU	584
Aveo	4	1206	62	01/2008		LMU	584
Aveo	4	1206	60	06/2008	11/2012	LMU	584
Aveo	4	1229	51	03/2011		LWD	584
Aveo	4	1229	63	03/2011		LDC	584
Aveo	4	1229	65	01/2019		LDC	584
Aveo	4	1248	55	07/2011	12/2015	LDV	586
Aveo	4	1248	70	07/2011	12/2015	LSF	586
Aveo	4	1364	103	09/2011		LUJ LUV	588
Aveo	4	1398	74	03/2011		LDD	588
Aveo	4	1399	69	05/2003		L14(85CUL4) L95	590
Aveo	4	1399	61	03/2005	05/2008	LX5(85CUL4)	590
Aveo	4	1399	74	04/2008		LDT	592
Aveo	4	1498	63	10/2004	05/2006	LV8(91CUL4)	596
Aveo	4	1498	62	01/2005		F15S3 LV8(91CUL4) LX6	596
Aveo	4	1498	64	02/2013		F15S3	596
Aveo	4	1595	77	01/2010		LXV	602
Aveo	4	1598	77	09/2003		L44(96CUL4) LXT LXV	598 600 602
Aveo	4	1598	76	05/2005		LXV	602
Aveo	4	1598	81	01/2007		LXT	600
Aveo	4	1598	75	01/2008		LXT	600
Aveo	4	1598	79	09/2008	12/2009	LXV	602
Aveo	4	1598	85	03/2011		LDE	600

CHEVROLET/ DAEWOO	ccm	kW	→	→			
Aveo	4	1598	88	06/2011		LDE LFJ	600
Aveo	4	1796	101	09/2011	07/2015	LUW LWE	602
Aveo	4	1796	103	07/2015		LUW LWE	602
Beat	4	1206	60	10/2017		LMU	584
Blazer	4	2457	144	06/2018		LCV	620
Brougham	4	1998	85	09/1991	12/1995	C20LE	610
Camaro	4	1998	205	09/2015		LTG	614
Camaro	4	1998	175	01/2016		LTG	614
Camaro	4	1998	203	01/2016		LTG	614
Camaro	4	1998	202	08/2016		LTG	614
Captiva	4	1956	125	01/2016		LFS	606
Captiva	4	2384	126	12/2009		LE5 LE9(145CUL4)	620
Captiva	4	2384	122	01/2011		LE5	620
Captiva	4	2384	124	01/2011		LE9(145CUL4)	620
Captiva	4	2384	123	03/2011		LE5	620
Captiva	4	2384	136	09/2011		LAF LEA	620
Captiva	4	2384	134	01/2012		LEA	620
Cavalier	4	1485	80	10/2017		L2B	592
Cavalier	4	2198	104	09/2001	08/2005	L61	616
Chevy	4	1389	44	12/1995	07/2006	2H6	588
Chevy	4	1389	45	09/2000	07/2006	2H6	588
Chevy	4	1389	66	08/2002	09/2006	2H6	588
Chevy	4	1598	74	05/2006		L44(96CUL4)	598
Cielo	4	1498	66	06/1994	07/1998	V15L	594
Cielo	4	1498	70	06/1994	03/1995	A15MF	594
Cielo	4	1498	55	04/1995	07/1997	Y15L	596
Classic	4	2198	108	09/2003	12/2005	L61	616
Cobalt	4	1998	152	07/2005	12/2008	LSJ	612
Cobalt	4	2198	108	04/2004		L61	616
Cobalt	4	2198	110	09/2006	12/2008	L61	616
Cobalt	4	2198	116	09/2008	12/2010	LAP	616
Cobalt	4	2384	128	07/2004		LE5	620
Colorado	4	2457	144	09/2014		LCV	620
Colorado	4	2457	145	09/2014		LCV	620

CHEVROLET/DAEWOO



CHEVROLET/ DAEWOO	ccm	kW	→	→		
Colorado	4	2457	149	09/2014		LCV 620
Colorado	4	2499	110	09/2012		XLD25 624
Colorado	4	2499	120	09/2015		XLD25 624
Colorado	4	2499	132	09/2015		XLD25 624
Colorado	4	2770	130	04/2003	12/2006	LK5 624
Colorado	4	2776	132	01/2004	08/2012	LWH 624
Colorado	4	2776	135	09/2015		LWN 626
Colorado	4	2776	149	01/2017		LWN 626
Colorado	4	2799	97	04/2003	12/2005	LJ6(171CUL4) 626
Colorado	4	2799	103	08/2005		LJ6(171CUL4) 626 LLK(171CUL4)
Colorado	4	2921	138	09/2006	12/2012	LLV 626
Colorado	4	2921	139	10/2006		LLV 626
Colorado	5	3460	164	09/2003	12/2006	L52 626
Colorado	5	3651	180	09/2006	12/2012	LLR 628
Colorado	5	3654	181	09/2007	12/2012	LLR 628
Corsa	4	1389	44	08/1994	07/1997	2H6 588 2H6(85CUL4)
Corsa	4	1389	66	01/2010	12/2012	2H6 588
Corsa	4	1796	75	08/2002		C 18 NE 604
Cruze	4	1362	103	06/2012		LUJ 588
Cruze	4	1364	103	09/2010		LUJ 588
Cruze	4	1398	74	07/2013		LDD 588
Cruze	4	1399	114	11/2015		LE2(85CUL4) 592
Cruze	4	1399	113	01/2017		LE2(85CUL4) 592
Cruze	4	1399	110	08/2019		LE2(85CUL4) 592
Cruze	4	1598	80	05/2009		LXT 600
Cruze	4	1598	83	05/2009		LDE 600
Cruze	4	1598	91	05/2009		LDE 600
Cruze	4	1598	86	12/2012		LDE 600
Cruze	4	1598	102	01/2017		LH7(98CUL4) 600
Cruze	4	1686	96	01/2012		LUD 602
Cruze	4	1686	81	08/2013		LKR 602
Cruze	4	1796	101	05/2009		LUW 602 LWE
Cruze	4	1796	104	05/2009		2H0 602
Cruze	4	1796	103	11/2009		2H0 602 LUW LWE

CHEVROLET/ DAEWOO	ccm	kW	→	→		
Cruze	4	1796	106	10/2011	12/2016	LFH 602 LUW
Cruze CDI	4	1956	110	09/2013		LUZ 608
Cruze CDI	4	1956	113	09/2013	12/2015	LUZ 608
Damas	3	796	28	03/1995	12/2011	F8B 580
Damas	3	797	29	10/1991	07/1998	F8B 580
Enjoy	4	1248	57	05/2013	03/2016	LDV 586
Enjoy	4	1248	55	10/2015	10/2017	LDV 586
Enjoy	4	1399	76	05/2013	03/2016	LCU 590
Enjoy	4	1399	74	10/2015	10/2017	LCU 590
Equinox	4	1490	127	07/2017		LYX 594
Equinox	4	1598	102	03/2017	12/2019	LH7(98CUL4) 600
Equinox	4	1998	188	03/2017		LTG 614
Equinox	4	1998	193	03/2017		LTG 614
Equinox	4	2384	136	09/2009	12/2017	LAF 620 LEA
Espero	4	1498	65	10/1993	09/1994	A15MF 594
Espero	4	1498	66	02/1995	06/1999	A15MF 594
Espero	4	1796	66	02/1995	09/1999	C18LE 604
Espero	4	1796	70	02/1995	06/1999	C18LE 604
Espero	4	1998	74	10/1991	09/1993	C20LZ 610
Espero	4	1998	81	10/1993	09/1994	C20LE 610
Espero	4	1998	77	02/1995	06/1999	C20LE 610
Evanda	4	1998	96	08/2002		X 20 SED 616
Express	4	2776	135	11/2017		LWN 626
G2X	4	1998	194	01/2008	02/2011	LNF 612
Gentra	4	1206	62	05/2007	02/2011	F12D4 584
Gentra	4	1399	69	05/2005		F14D3 590
Gentra	4	1485	79	06/2013		B 15 D2 592
Gentra	4	1498	62	11/2002	04/2005	A15SMS 596
Gentra	4	1598	77	05/2005		F16D3 600
Groove	4	1485	81	10/2021		L2B 592
HHR	4	2198	107	09/2005	12/2006	L61 616
HHR	4	2198	111	09/2005	12/2008	L61 616
HHR	4	2198	108	01/2006	12/2011	L61 616
HHR	4	2198	116	09/2008	12/2010	LE8(134CUL4) 618
HHR	4	2198	120	09/2010	12/2011	LE8(134CUL4) 618

CHEVROLET/DAEWOO



CHEVROLET/ DAEWOO	ccm	kW	→	→			
HHR	4	2384	128	01/2006	12/2011	LE5 LE9(145CUL4)	620
HHR	4	2384	130	09/2006	12/2007	LE5	620
HHR	4	2384	125	10/2007	12/2011	LE5	620
HHR	4	2384	131	09/2009	12/2011	LE9(145CUL4)	620
Impala	4	2384	136	07/2013	12/2014	LUK	620
Impala	4	2384	147	06/2014		LUK	620
Impala	4	2457	145	07/2013		LCV LKW	620 622
Impala	4	2457	146	03/2016		LKW	622
Ipanema	4	1998	85	03/1991	12/1997	LT0(122CUL4)	610
Kadett	4	1998	85	03/1991	12/1997	LT0(122CUL4)	610
Kalos	4	1150	53	04/2003		B12S3	582
Kalos	4	1399	69	04/2003		F14D3	590
Kalos	4	1399	61	03/2005		LX5(85CUL4)	590
Kalos	4	1598	78	02/2003		F16S4	598
Lacetti	4	1399	69	06/2002	03/2013	F14D3 L14(85CUL4)	590
Lacetti	4	1399	70	02/2004		F14D3 L14(85CUL4)	590
Lacetti	4	1498	78	01/2003	12/2005	F15D3	594
Lacetti	4	1498	63	08/2003	12/2004	A15SMS	596
Lacetti	4	1598	78	06/1999	07/2003	A16DMS	598
Lacetti	4	1598	80	02/2004		F16D3 L44(96CUL4) LXT	598 600
Lacetti	4	1799	90	05/2003	08/2005	L84(110CUL4)	606
Lacetti	4	1991	89	01/2007		LMN	608
Lacetti	4	1991	110	02/2009	02/2011	LLW	608
Lacetti	4	1998	81	06/1999	07/2003	C20SED	610
Lacetti	4	1998	98	06/1999	07/2003	X 20 SED	616
Lanos	4	1498	63	05/1997		LX6 LX6(91CUL4)	596
Lanos	4	1498	71	10/1997	04/2001	LX6(91CUL4)	596
Lanos	4	1498	64	11/2005	12/2018	LX6	596
Lanos	4	1598	78	02/1997		L44(96CUL4) L44(98CUL4)	598 598
Leganza	4	1796	70	06/1997	07/2003	C18LE	604
Leganza	4	1998	85	06/1997	12/2002	X 20 SED	616
Leganza	4	1998	98	06/1997	12/2002	X 20 SED	616
Leganza	4	2198	100	04/1999	12/2002	T22SED	618

CHEVROLET/ DAEWOO	ccm	kW	→	→			
Le Mans	4	1998	72	09/1990	07/1993	C20LE	610
Magnus	4	1998	96	07/1999	01/2006	X 20 SED	616
Malibu	4	1490	122	09/2015		LFV	594
Malibu	4	1490	119	03/2016		LFV	594
Malibu	4	1956	115	04/2012		LBS	606
Malibu	4	1956	118	04/2012		LBS	606
Malibu	4	1998	193	01/2012		LTG	614
Malibu	4	1998	186	09/2015		LTG	614
Malibu	4	2198	104	10/2001	09/2003	L61	616
Malibu	4	2198	107	10/2003	12/2006	L61	616
Malibu	4	2198	108	10/2003	12/2008	L61	616
Malibu	4	2384	122	01/2008	12/2010	LAT	618
Malibu	4	2384	126	01/2008	12/2012	LE5	620
Malibu	4	2384	130	09/2009	12/2012	LE9(145CUL4)	620
Malibu	4	2384	127	01/2010		LE5	620
Malibu	4	2384	123	01/2012		LE9(145CUL4)	620
Malibu	4	2384	125	01/2012		LE9(145CUL4)	620
Malibu	4	2384	136	01/2012		LUK	620
Malibu	4	2457	142	09/2012	12/2013	LCV	620
Malibu	4	2457	147	07/2013		LCV LKW	620 622
Malibu	4	2457	146	09/2013	12/2015	LCV	620
Malibu	4	2457	137	09/2015		LKW	622
Matiz	3	796	38	03/2005	12/2013	LBF(49CUL3) LQ2(49CUL3)	580
Matiz	3	796	37	10/2010		F8CV	580
Matiz	4	995	47	01/2003		B10S	582
Matiz	4	995	46	04/2003	12/2004	B10S	582
Matiz	4	995	49	03/2005	03/2011	LA2 LA2(61CUL4) LQ4(61CUL4)	582
Matiz	4	995	44	01/2007	05/2017	LA2	582
Matiz	4	995	48	01/2007		B10S1 LA2	582
Matiz	4	995	51	01/2010	11/2012	F10D4	580
Meriva	4	1796	75	02/2002	07/2012	C 18 NE	604
Montana	4	1248	55	01/2011		LDP	584
Monza	4	1796	72	02/1994	09/2002	18N	602
Monza	4	1988	85	03/1991	12/1996	LT0(122CUL4)	610



CHEVROLET/ DAEWOO	ccm	kW	→	→		
N300	4	1206	60	06/2011		LMU 584
N300	4	1485	78	03/2012		L2B 592
Nexia	4	1498	66	02/1995	08/1997	A15MF 594
Nexia	4	1498	59	07/2008		Y15L 596
Nexia	4	1598	80	07/2008		F16D3 600
Nexia	4	1796	74	02/1995	06/2008	C18LE 604
Nubira	4	1399	69	10/2003	12/2007	F14D3 590 L14(85CUL4)
Nubira	4	1399	70	01/2006	12/2008	L14(85CUL4) 590
Nubira	4	1598	85	04/1997	04/1998	A16DMS 598
Nubira	4	1598	78	05/1997	12/2002	A16DMS 598
Nubira	4	1598	66	06/1997		A16DMS 598
Nubira	4	1598	76	07/2000		A16DMS 598 LXT 600
Nubira	4	1598	80	07/2003		F16D3 598 L44(96CUL4) 600 LXT
Nubira	4	1796	100	04/1997	05/1999	L84(110CUL4) 604
Nubira	4	1796	70	06/2004		C18LE 604
Nubira	4	1991	89	01/2005	12/2011	LMN 608
Nubira	4	1998	98	05/1997		X 20 SED 616
Nubira	4	1998	96	09/1998	12/2002	X 20 SE 614 X 20 SED 616
Nubira	4	1998	81	06/1999	07/2003	C20SED 610
Omega	4	1998	96	03/1993	12/1995	L78(122CUL4) 610
Optra	4	1485	82	01/2015		L2B 592
Optra	4	1598	78	08/2003	11/2012	LXT 600
Optra	4	1598	80	08/2003	12/2008	L44(96CUL4) 598 LXT 600
Optra	4	1598	74	11/2006		LXT 600
Orlando	4	1362	103	06/2012		LUJ 588
Orlando	4	1796	104	02/2011		2H0 602
Orlando	4	2384	130	09/2011		LAF 620 LEA
Orlando	4	2384	134	01/2013		LEA 620
Prince	4	1796	74	08/1990	08/1997	S 18 NV 604
Prince	4	1796	76	08/1993	08/1998	C18LE 604
Prince	4	1998	74	08/1992	07/1995	C20LZ 610
Prince	4	1998	85	08/1994	12/1998	C 20 NED 610 C20LE

CHEVROLET/ DAEWOO	ccm	kW	→	→		
Rezzo	4	1598	77	09/2000		A16DMS 598 L44(96CUL4)
Rezzo	4	1598	78	02/2002	12/2004	A16DMS 598
Rezzo	4	1598	66	03/2005	03/2009	L44(96CUL4) 598
Rezzo	4	1598	79	08/2005		L44(96CUL4) 598
Rezzo	4	1998	77	06/2000	12/2001	C 20 NL 610
Rezzo	4	1998	70	01/2002	12/2007	C 20 NL 610
Royale	4	1998	85	04/1989	08/1993	C 20 NED 610
S10	4	2457	145	09/2014		LCV 620
S10	4	2457	152	09/2014		LCV 620
S10	4	2776	132	02/2012	08/2013	LWH 624
S10	4	2776	147	09/2013		LWN 626
S10	4	2798	97	02/2000	12/2011	LJ6(171CUL4) 626
S10 Blazer	4	2799	103	08/2005	12/2009	LLK(171CUL4) 626 Y28DTC
Sail	4	1199	63	01/2013	10/2017	10CXD 582 LC5(73CUL4)
Sail	4	1199	61	10/2014	10/2017	LC5(73CUL4) 582
Sail	4	1206	65	04/2012		LMU 584
Sail	4	1248	57	01/2013	10/2017	LDV 586
Sail	4	1248	55	12/2014	10/2017	LDV 586
Sail	4	1349	73	01/2015		LEW 586
Sail	4	1399	75	10/2010		LCU 590
Sail	4	1485	80	01/2015		L2B 592
Spark	3	796	38	09/2000	08/2014	F8CV 580
Spark	3	796	37	05/2005	02/2010	LBF(49CUL3) 580 LQ2(49CUL3)
Spark	3	936	43	07/2011	09/2012	10 AB5 580
Spark	3	936	46	07/2011	10/2017	10 AB5 580
Spark	3	936	42	09/2014	10/2017	Z10DT 580
Spark	4	995	46	05/2005		LA2 582
Spark	4	995	44	06/2009		LA2 582
Spark	4	995	50	03/2010		LMT 580
Spark	4	995	48	07/2010		B10D1 580 LMT
Spark	4	995	45	03/2014	05/2017	B10S1 582
Spark	3	999	54	11/2015		B 10 XE 582
Spark	3	999	55	11/2015		B 10 XE 582
Spark	4	1199	59	12/2009		LC5(73CUL4) 582

CHEVROLET/DAEWOO



CHEVROLET/ DAEWOO		ccm	kW	→	→		
Spark	4	1199	61	01/2011	10/2017	LC5(73CUL4)	582
Spark	4	1199	57	10/2012	10/2017	LC5(73CUL4)	582
Spark	4	1206	60	03/2010		LMU	584
Spark	4	1399	72	11/2015		LV7	592
Spark	4	1399	73	11/2015		LV7	592
Spark	4	1399	74	11/2015		LV7	592
Spin	4	1229	63	06/2012		LDC	584
Super Saloon	4	1796	74	08/1992	08/1995	S 18 NV	604
Super Saloon	4	1998	85	04/1989	08/1995	C 20 NED	610
Tico	3	796	30	01/1991	12/1994	F8C	580
Tico	3	796	35	02/1995	12/2000	F8C	580
Tico	3	796	27	08/1995	05/1997	F8B	580
Tosca	4	1991	110	02/2006		Z 20 DMH	608
Trailblazer	4	2499	110	08/2012		LVN	622
Trailblazer	4	2499	120	08/2016		XLD25	624
Trailblazer	4	2499	132	08/2016		XLD25	624
Trailblazer	4	2776	132	08/2012		LWH VM	624
Trailblazer	4	2776	144	07/2014		LWH	624
Trailblazer	4	2776	147	07/2014		LWN	626
Trailblazer	4	2776	128	10/2016		LWH	624
Trailblazer	6	4157	201	09/2001	09/2008	LL8(254CUL6)	628
Trailblazer	6	4157	205	09/2002	12/2009	LL8(254CUL6)	628
Trailblazer	6	4157	217	08/2005	09/2008	LL8(254CUL6)	628
Trailblazer	6	4157	213	09/2007	12/2009	LL8(254CUL6)	628
Traverse	4	1998	190	07/2017		LTG	614
Trax	4	1364	103	12/2012		LUJ	588
Trax	4	1399	113	01/2017		LE2(85CUL4)	592
Trax	4	1399	115	04/2021		LE2(85CUL4)	592
Trax	4	1598	85	12/2012		LDE	600
Trax	4	1598	100	11/2014	12/2015	LVL	600
Trax	4	1686	96	12/2012		LUD	602
Trax	4	1796	103	03/2013		2H0	602
Trax	4	1796	106	10/2013	02/2017	LFH	602
Vectra	4	2198	108	04/2002	04/2004	L61	616
Vivant	4	1598	78	08/2001		L44(96CUL4)	598
Vivant	4	1598	77	01/2005	03/2009	L44(96CUL4)	598

CHEVROLET/ DAEWOO		ccm	kW	→	→		
Volt			111	05/2015		L3A	594
Volt	4	1398	111	11/2011		LUU	590
Volt	4	1490	75	01/2016		L3A	594
Winstorm	4	1991	113	01/2007	02/2011	LLW	608



CHEVROLET/DAEWOO



10 AB5	3	936	580
10CXD	4	1199	582
18N	4	1796	602
2H0	4	1796	602
2H6	4	1389	588
2H6(85CUL4)	4	1389	588
A08S3	3	796	580
A15MF	4	1498	594
A15SMS	4	1498	596
A16DMS	4	1598	598
B10D1	4	995	580
B10S	4	995	582
B10S1	4	995	582
B 10 XE	3	999	582
B12D1	4	1206	584
B12S1	4	1150	582
B12S3	4	1150	582
B 15 D2	4	1485	592
C18LE	4	1796	604
C 18 NE	4	1796	604
C20LE	4	1998	610
C20LZ	4	1998	610
C 20 NE	4	1998	610
C 20 NED	4	1998	610
C 20 NL	4	1998	610
C20SED	4	1998	610
C 20 SED	4	1998	610
F10D4	4	995	580
F12D4	4	1206	584
F12S3	4	1150	582
F14D3	4	1399	590
F14S3	4	1399	590
F15D3	4	1498	594
F15S3	4	1498	596
F16D3	4	1598	600
F16S4	4	1598	598
F18D4	4	1796	602

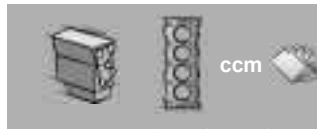

F8B	3	796	580
F8C	3	796	580
F8CV	3	796	580
L11(61CUL4)	4	995	582
L14(85CUL4)	4	1399	590
L2B	4	1485	592
L3A	4	1490	594
L44(96CUL4)	4	1598	598
L44(98CUL4)	4	1598	598
L52	5	3460	626
L61	4	2198	616
L78(122CUL4)	4	1998	610
L84(110CUL4)	4	1799	606
L84(110CUL4)	4	1796	604
L88	4	1998	612
L95	4	1399	590
LA2	4	995	582
LA2(61CUL4)	4	995	582
LAF	4	2384	620
LAP	4	2198	616
LAT	4	2384	618
LBF(49CUL3)	3	796	580
LBS	4	1956	606
LC5(110CUL4)	4	1796	604
LC5(73CUL4)	4	1199	582
LCU	4	1399	590
LCV	4	2457	620
LDC	4	1229	584
LDD	4	1398	588
LDE	4	1598	600
LDP	4	1248	584
LDT	4	1399	592
LDV	4	1248	586
LE2(85CUL4)	4	1399	592
LE5	4	2384	620
LE8(134CUL4)	4	2198	618
LE9(145CUL4)	4	2384	620



LEA	4	2384	620
LEW	4	1349	586
LFH	4	1796	602
LFJ	4	1598	600
LFS	4	1956	606
LFV	4	1490	594
LH7(98CUL4)	4	1598	600
LJ6(171CUL4)	4	2798	626
LK5	4	2770	624
LKH	4	2499	622
LKR	4	1686	602
LKW	4	2457	622
LL8(254CUL6)	6	4157	628
LLK	4	2798	626
LLK(171CUL4)	4	2798	626
LLR	5	3653	628
LLV	4	2921	626
LLW	4	1991	608
LMN	4	1991	608
LMT	4	995	580
LMU	4	1206	584
LNF	4	1998	612
LQ2(49CUL3)	3	796	580
LQ4(61CUL4)	4	995	582
LQ5(70CUL4)	4	1150	582
LSF	4	1248	586
LSJ	4	1998	612
LT0(122CUL4)	4	1998	610
LTG	4	1998	614
LUD	4	1686	602
LUJ	4	1364	588
LUK	4	2384	620
LUU	4	1398	590
LUV	4	1364	588
LUW	4	1796	602
LUZ	4	1956	608
LV7	4	1399	592

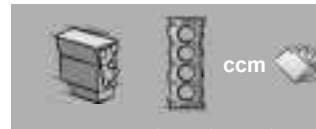







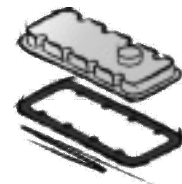
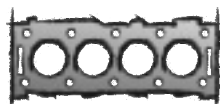
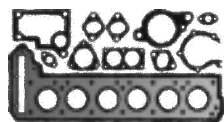









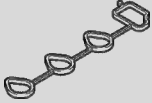

LV8(91CUL4)	4	1498	596
LVL	4	1598	600
LVN	4	2499	622
LWD	4	1229	584
LWE	4	1796	602
LWH	4	2776	624
LWN	4	2776	626
LWQ	4	1598	600
LWV	4	1598	600
LX5(85CUL4)	4	1399	590
LX6	4	1498	596
LX6(91CUL4)	4	1498	596
LXT	4	1598	600
LXV	4	1598	602
LY4	4	1150	582
LYX	4	1490	594
S 18 NV	4	1796	604
T18SED	4	1799	606
T20SED	4	1998	614
T22SED	4	2198	618
V15L	4	1498	594
VM	4	2776	624
X 20 SE	4	1998	614
X 20 SED	4	1998	616
XLD25	4	2499	624
Y15L	4	1498	596
Y18L	4	1796	604
Y28DTC	4	2798	626
Z10DT	3	936	580
Z 20 DM	4	1991	608
Z 20 DMH	4	1991	608
Z 20 S	4	1991	608
Z 20 S1	4	1991	608



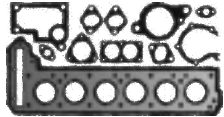
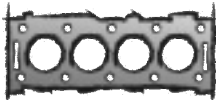

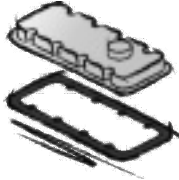
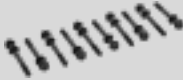

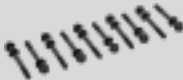
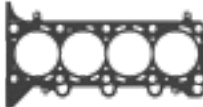

















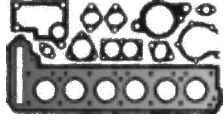
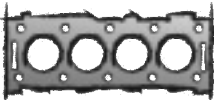

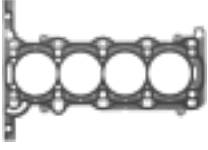

**CHEVROLET/
DAEWOO**

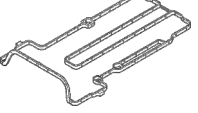







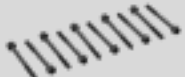
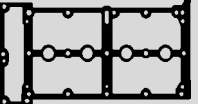





			<p>a) </p> <p>b) </p>	<p>K: </p> <p>N: </p>	
<p>166.190 09289-05013 FPM 6x</p>	<p>166.240 96353036</p> 	<p>166.210 96352281</p> 	<p>a) 036.164 Dirko HT / EU</p> <p>a) 510.031 Dirko HT / USA/CDN/MEX</p> <p>a) 527.291 Dirko HT / RU</p> <p>a) 648.661 Dirko HT / BR</p> <p>b) 774.460 94535699 M 14x1,5x11</p> <p>b) 928.580 94 525 246 Metal 13,8x19x2,3</p>	<p>K:← 166.160 94535472 AS RD FPM 32x47x6</p> <p>K:→ 166.180 09283-60005 AS LD VMQ 60x80x8</p> <p>N:← 166.160 94535472 AS RD FPM 32x47x6</p>	
<p>938.620 96440882 FPM 16x</p> 	<p>929.530 96 416 309 96 EEC</p>  <p>935.780 96 940 384</p>	<p>947.790 96 416 314</p> 	<p>a) 036.164 Dirko HT / EU</p> <p>a) 510.031 Dirko HT / USA/CDN/MEX</p> <p>a) 527.291 Dirko HT / RU</p> <p>a) 648.661 Dirko HT / BR</p> <p>b) 774.460 94535699 M 14x1,5x11</p> <p>b) 928.580 94 525 246 Metal 13,8x19x2,3</p>	<p>K:← 938.260 96416399 AS RD FPM 36x50x6</p> <p>K:→ 196.180 96 416 398 AS LD FPM 60x80x8</p>	

<p>CHEVROLET/ DAEWOO</p> 				
<p>B10S B10S1 L11(61CUL4) LA2 LA2(61CUL4) LQ4(61CUL4)</p> <p>4 Cyl. 995 ccm Cyl. 68,5 Ø</p> <p>Matiz 01/2003 →</p> <p>Spark 05/2005 →</p>			<p>ZKS 471.770 94580081 (10x) M 10x1,25x97</p> 	<p>571.730 96 325 175</p>
<p>B 10 XE</p> <p>3 Cyl. 999 ccm Cyl. 74,0 Ø</p> <p>Spark 11/2015 →</p>		<p>590.420 12 637 389 0,86 mm $\frac{1}{2}$ 75,1 Ø</p> 	<p>ZKS 444.100 11 548 125 (8x) M 10x1,5x110</p> 	
<p>B12S1/3 F12S3 LQ5(70CUL4) LY4</p> <p>4 Cyl. 1150 ccm Cyl. 68,5 Ø</p> <p>Aveo 01/2004 →</p> <p>Kalos 04/2003 →</p>			<p>ZKS 471.770 94580081 (10x) M 10x1,25x97</p> 	<p>571.730 96 325 175</p>
<p>10CXD LC5(73CUL4)</p> <p>4 Cyl. 1199 ccm Cyl. 69,5 Ø</p> <p>Sail 01/2013 → 10/2017</p> <p>Spark 12/2009 →</p>	<p>CS* 497.150</p>	<p>927.930 25 184 663</p> 		<p>972.940 96416270</p> 





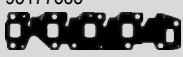



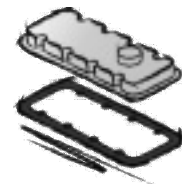
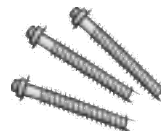
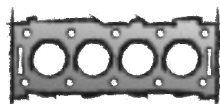
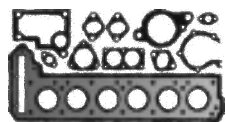



			<p>a) </p> <p>b) </p>	<p>K: </p> <p>N: </p>	
<p>166.190 09289-05013 FPM 8x</p>			<p>a) 036.164 Dirko HT / EU</p> <p>a) 510.031 Dirko HT / USA/CDN/MEX</p> <p>a) 527.291 Dirko HT / RU</p> <p>a) 648.661 Dirko HT / BR</p> <p>b) 774.460 94535699 M 14x1,5x11</p> <p>b) 928.580 94 525 246 Metal 13,8x19x2,3</p>	<p>K:← 166.160 94535472 AS RD FPM 32x47x6</p> <p>K:→ 166.180 09283-60005 AS LD VMQ 60x80x8</p> <p>N:← 166.160 94535472 AS RD FPM 32x47x6</p>	
<p>597.400 12661725 FPM 12x</p> 			<p>a) 036.164 Dirko HT / EU</p> <p>a) 510.031 Dirko HT / USA/CDN/MEX</p> <p>a) 527.291 Dirko HT / RU</p> <p>a) 648.661 Dirko HT / BR</p> <p>b) 823.400 55 577 568 +12 616 850 M 12x1,75x17</p> <p>b) 056.130 12 616 850 FPM RD 10,8x20,8x2,6</p>	<p>K:← 587.430 12 661 527 A/BS OF RD FPM 44x60x8,5</p> <p>K:→ 481.450 12 653 685 A/BS OF LD FPM 84x100x8,9</p>	
<p>166.190 09289-05013 FPM 8x</p>			<p>a) 036.164 Dirko HT / EU</p> <p>a) 510.031 Dirko HT / USA/CDN/MEX</p> <p>a) 527.291 Dirko HT / RU</p> <p>a) 648.661 Dirko HT / BR</p> <p>b) 774.460 94535699 M 14x1,5x11</p> <p>b) 928.580 94 525 246 Metal 13,8x19x2,3</p>	<p>K:← 166.160 94535472 AS RD FPM 32x47x6</p> <p>K:→ 166.180 09283-60005 AS LD VMQ 60x80x8</p> <p>N:← 166.160 94535472 AS RD FPM 32x47x6</p>	
<p>938.620 96440882 FPM 16x</p> 	<p>929.530 96 416 309 96 EEC</p>  <p>935.780 96 940 384</p>	<p>947.790 96 416 314</p> 	<p>a) 036.164 Dirko HT / EU</p> <p>a) 510.031 Dirko HT / USA/CDN/MEX</p> <p>a) 527.291 Dirko HT / RU</p> <p>a) 648.661 Dirko HT / BR</p> <p>b) 774.460 94535699 M 14x1,5x11</p> <p>b) 928.580 94 525 246 Metal 13,8x19x2,3</p>	<p>K:← 938.260 96416399 AS RD FPM 36x50x6</p> <p>K:→ 196.180 96 416 398 AS LD FPM 60x80x8</p>	

CHEVROLET/ DAEWOO  Das Original					
B12D1 F12D4 LMU 4 Cyl. 1206 ccm Cyl. 69,7 Ø Aveo 01/2008 → Beat 10/2017 → Genra 05/2007 → 02/2011 N300 06/2011 → Sail 04/2012 → Spark 03/2010 →	CS* 497.150	927.930 25 184 663 	972.940 96416270 		
LDC LWD 4 Cyl. 1229 ccm Cyl. 73,4 Ø Aveo 03/2011 → Spin 06/2012 →	S⊕* 779.800 08/2012→ ES⊕ 744.150 93168201 →07/2012 ES⊕ 779.670 08/2012→ CS* 384.561 SZ← 689.350	493.141 55562233 0,52 mm $\frac{1}{2}$ 73,9 Ø 	ZKS 751.970 55566811(10x) M 9x1,25x121  691.370 55561429 →07/2012  773.410 55573747 08/2012→ 		
LDP 4 Cyl. 1248 ccm Cyl. 69,6 Ø Montana 01/2011 →		076.348  0,028 mm → 0,127 mm 0,72 mm $\frac{1}{2}$ 70,6 Ø 076.358  0,128 mm → 0,227 mm 0,82 mm $\frac{1}{2}$ 70,6 Ø 1 ⊗ 076.408  0,228 mm → 0,327 mm 0,92 mm $\frac{1}{2}$ 70,6 Ø 2 ⊗   	ZKS 374.240 93177254(10x) M 10x1,25x119  074.173 12855434 		

			<p>a) </p> <p>b) </p>	<p>K: </p> <p>N: </p>	
<p>938.620 96440882 FPM 16x</p> 	<p>929.530 96 416 309 96 EEC</p>  <p>935.780 96 940 384</p>	<p>947.790 96 416 314</p> 	<p>a) 036.164 Dirko HT / EU</p> <p>a) 510.031 Dirko HT / USA/CDN/MEX</p> <p>a) 527.291 Dirko HT / RU</p> <p>a) 648.661 Dirko HT / BR</p> <p>b) 774.460 94535699 M 14x1,5x11</p> <p>b) 928.580 94 525 246 Metal 13,8x19x2,3</p>	<p>K:← 938.260 96416399 AS RD FPM 36x50x6</p> <p>K:→ 196.180 96 416 398 AS LD FPM 60x80x8</p>	
<p>476.691 09158057 FPM 16x</p>	<p>809.333 55566925</p> 	<p>690.740 55563660 4x</p> 	<p>a) 036.164 Dirko HT / EU</p> <p>a) 510.031 Dirko HT / USA/CDN/MEX</p> <p>a) 527.291 Dirko HT / RU</p> <p>a) 648.661 Dirko HT / BR</p> <p>b) 274.410 96 023 264 M 14x1,5x13,5</p> <p>b) 476.750 90 528 145 FPM RD 18x22x2</p>	<p>K:← 127.610 90571925 ASW RD FPM/ACM 42x55x7</p> <p>K:← 595.170 12584041 AW/BS OF RD FPM 42x55x7</p> <p>K:→ 590.797 96101489 A/BS LD FPM 80x98x10</p>	
<p>VAS 445.100 FPM</p>	<p>431.310 93177335</p> 		<p>a) 036.164 Dirko HT / EU</p> <p>a) 510.031 Dirko HT / USA/CDN/MEX</p> <p>a) 527.291 Dirko HT / RU</p> <p>a) 648.661 Dirko HT / BR</p>	<p>K:← 445.060 93177701 AW/BS RD FPM 40x52x7</p> <p>K:→ 428.970 93177284 ASW LD PTFE/ACM 78x100x9</p>	

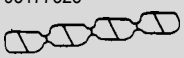







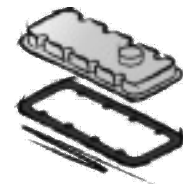
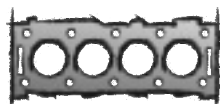
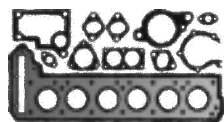







**CHEVROLET/
DAEWOO**

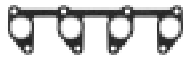

			<p>a) </p> <p>b) </p>	<p>K: </p> <p>N: </p>	
<p>VAS 445.100 FPM</p>	<p>431.310 93177335</p> 	<p>431.180 93177328</p> 	<p>a) 036.164 Dirko HT / EU</p> <p>a) 510.031 Dirko HT / USA/CDN/MEX</p> <p>a) 527.291 Dirko HT / RU</p> <p>a) 648.661 Dirko HT / BR</p>	<p>K:← 445.060 93177701 AW/BS RD FPM 40x52x7</p> <p>K:→ 428.970 93177284 ASW LD PTFE/ACM 78x100x9</p>	<p>TLS 715.320</p> 
<p>VAS 445.100 FPM</p>	<p>789.400 55569044</p> 	<p>718.200 93195414 4x</p> 	<p>a) 036.164 Dirko HT / EU</p> <p>a) 510.031 Dirko HT / USA/CDN/MEX</p> <p>a) 527.291 Dirko HT / RU</p> <p>a) 648.661 Dirko HT / BR</p>	<p>K:← 445.060 93177701 AW/BS RD FPM 40x52x7</p> <p>K:→ 428.970 93177284 ASW LD PTFE/ACM 78x100x9</p>	<p>TLS 007.810</p> 
			<p>a) 036.164 Dirko HT / EU</p> <p>a) 510.031 Dirko HT / USA/CDN/MEX</p> <p>a) 527.291 Dirko HT / RU</p> <p>a) 648.661 Dirko HT / BR</p>		









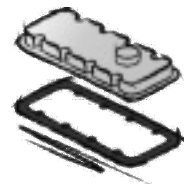
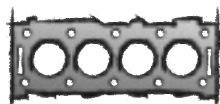
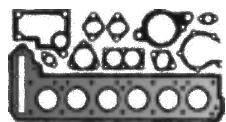

**CHEVROLET/
DAEWOO**







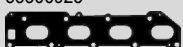



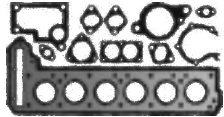
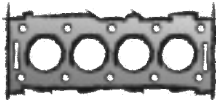

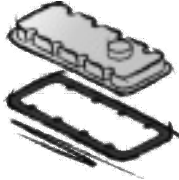



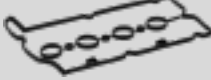
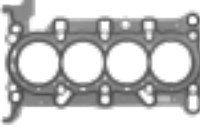

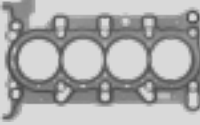

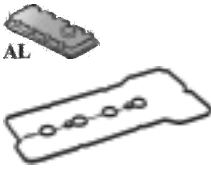







			<p>a) </p> <p>b) </p>	<p>K: </p> <p>N: </p>	
<p>476.691 09158057 FPM 16x</p>	<p>132.130 55565348</p> 	<p>690.750 55 566 664</p> 	<p>a) 036.164 Dirko HT / EU</p> <p>a) 510.031 Dirko HT / USA/CDN/MEX</p> <p>a) 527.291 Dirko HT / RU</p> <p>a) 648.661 Dirko HT / BR</p> <p>b) 274.410 96 023 264 M 14x1,5x13,5</p> <p>b) 587.880 55 568 037 M 14x1,5x16</p> <p>b) 476.750 90 528 145 FPM RD 18x22x2</p>	<p>K:← 127.610 90571925 ASW RD FPM/ACM 42x55x7</p> <p>K:← 595.170 12584041 AW/BS OF RD FPM 42x55x7</p> <p>K:→ 590.797 96101489 A/BS LD FPM 80x98x10</p>	<p>TLS 521.100</p> 
<p>VAS 216.730</p> <p>586.693 94580655 FPM 8x</p>	<p>645.710 96181207 90412459</p> 	<p>805.180 Metal 24417040</p>  <p>825.354 903223399</p> 	<p>a) 766.390 90409693</p>  <p>FE</p>  <p>b) 773.630 90 409 376 M 14x1,5x12</p> <p>b) 115.100 94525114 CU A 14x20x1,5</p>	<p>K:← 755.141 90501719 ASW RD FPM/ACM 26x42x8</p> <p>K:→ 590.797 96101489 A/BS LD FPM 80x98x10</p> <p>N:← 702.269 96183314 AW/BS RD VMQ 35x48x7</p>	
<p>476.691 09158057 FPM 16x</p>	<p>809.333 55566925</p> 	<p>690.740 55563660 4x</p> 	<p>a) 036.164 Dirko HT / EU</p> <p>a) 510.031 Dirko HT / USA/CDN/MEX</p> <p>a) 527.291 Dirko HT / RU</p> <p>a) 648.661 Dirko HT / BR</p> <p>b) 274.410 96 023 264 M 14x1,5x13,5</p> <p>b) 476.750 90 528 145 FPM RD 18x22x2</p>	<p>K:← 127.610 90571925 ASW RD FPM/ACM 42x55x7</p> <p>K:← 595.170 12584041 AW/BS OF RD FPM 42x55x7</p> <p>K:→ 590.797 96101489 A/BS LD FPM 80x98x10</p>	











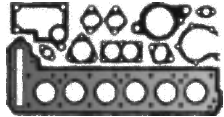
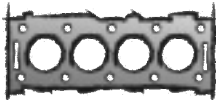

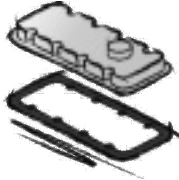
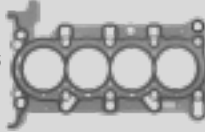
**CHEVROLET/
DAEWOO**

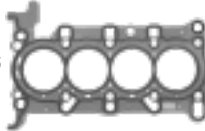



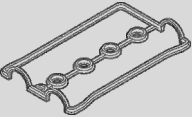



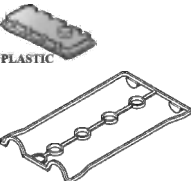











			<p>a) </p> <p>b) </p>	<p>K: </p> <p>N: </p>	
<p>476.691 09158057 FPM 16x</p>	<p>809.333 55566925</p> 		<p>a) 036.164 Dirko HT / EU</p> <p>a) 510.031 Dirko HT / USA/CDN/MEX</p> <p>a) 527.291 Dirko HT / RU</p> <p>a) 648.661 Dirko HT / BR</p> <p>b) 587.880 55 568 037 M 14x1,5x16</p>	<p>K:← 127.610 90571925 ASW RD FPM/ACM 42x55x7</p> <p>K:← 595.170 12584041 AW/BS OF RD FPM 42x55x7</p> <p>K:→ 590.797 96101489 A/BS LD FPM 80x98x10</p>	
<p>165.560 96353035 FPM 16x</p>	<p>165.590 96350469</p> 	<p>527.910 96461130 4x</p> 	<p>a) 036.164 Dirko HT / EU</p> <p>a) 510.031 Dirko HT / USA/CDN/MEX</p> <p>a) 527.291 Dirko HT / RU</p> <p>a) 648.661 Dirko HT / BR</p> <p>b) 774.460 94535699 M 14x1,5x11</p> <p>b) 115.100 94525114 CU A 14x20x1,5</p>	<p>K:← 505.838 ASW RD FPM 30x42x7</p> <p>K:← 598.760 96 350 161 AS RD FPM 30x42x8</p> <p>K:→ 590.797 96101489 A/BS LD FPM 80x98x10</p> <p>N:← 757.497 94580413 ASW RD FPM 42x56x7 2x</p>	
			<p>a) 036.164 Dirko HT / EU</p> <p>a) 510.031 Dirko HT / USA/CDN/MEX</p> <p>a) 527.291 Dirko HT / RU</p> <p>a) 648.661 Dirko HT / BR</p> <p>b) 774.460 94535699 M 14x1,5x11</p> <p>b) 115.100 94525114 CU A 14x20x1,5</p>	<p>K:← 440.720 96350161 ASW RD ACM 30x42x7</p> <p>K:← 505.838 ASW RD FPM 30x42x7</p> <p>K:→ 590.797 96101489 A/BS LD FPM 80x98x10</p> <p>N:← 702.269 96183314 AW/BS RD VMQ 35x48x7</p>	

<p>CHEVROLET/ DAEWOO</p> 				
<p>LDT</p> <p>4 Cyl. 1399 ccm Cyl. 77,9 Ø</p> <p>Aveo 04/2008 →</p>	<p>ES⊕ 504.200 93190885</p> <p>CS* 539.690 55568528</p> <p>OKS 599.160</p> 	<p>076.892 93186222</p> <p>0,65 mm $\frac{\pm}{\pm}$ 81,7 Ø</p> 	<p>ZKS 803.060 90412701(10x) M 10x1,25x153</p> 	<p>354.030 55354237</p> 
<p>LE2(85CUL4)</p> <p>4 Cyl. 1399 ccm Cyl. 73,8 Ø</p> <p>Cruze 11/2015 →</p> <p>Trax 01/2017 →</p>	<p>ES⊕ 911.980 12 679 878</p> <p>CS* 887.260</p> <p>CS* 910.720</p>	<p>259.821 12681524</p> <p>1,00 mm $\frac{\pm}{\pm}$ 75,2 Ø</p> 	<p>ZKS 940.160 11 548 125 (10x) M 10x1,5x110</p> 	<p>ZKHS 910.680 12 664 830</p> <p>599.290 12 636 176</p> 
<p>LV7</p> <p>4 Cyl. 1399 ccm Cyl. 74,0 Ø</p> <p>Spark 11/2015 →</p>	<p>ES⊕ 929.340 12 668 644</p> <p>CS* 910.710</p>	<p>259.821 12681524</p> <p>1,00 mm $\frac{\pm}{\pm}$ 75,2 Ø</p> 	<p>ZKS 940.160 11 548 125 (10x) M 10x1,5x110</p> 	<p>ZKHS 907.080</p> <p>599.290 12 636 176 2x</p> 
<p>B 15 D2 L2B</p> <p>4 Cyl. 1485 ccm Cyl. 74,7 Ø</p> <p>Cavalier 10/2017 →</p> <p>Gentra 06/2013 →</p> <p>Groove 10/2021 →</p> <p>N300 03/2012 →</p> <p>Optra 01/2015 →</p> <p>Sail 01/2015 →</p>				<p>314.491 24102543</p> <p>AL</p> 









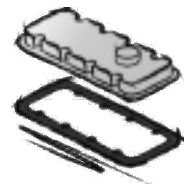
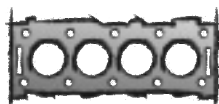
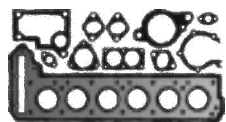







			<p>a) </p> <p>b) </p>	<p>K: </p> <p>N: </p>	
<p>061.760 24405819 FPM 16x</p>	<p>355.340 12992396</p> 	<p>504.260 55559374</p> 	<p>a) 036.164 Dirko HT / EU</p> <p>a) 510.031 Dirko HT / USA/CDN/MEX</p> <p>a) 527.291 Dirko HT / RU</p> <p>a) 648.661 Dirko HT / BR</p> <p>b) 274.410 96 023 264 M 14x1,5x13,5</p> <p>b) 476.750 90 528 145 FPM RD 18x22x2</p>	<p>K:← 056.900 24465791 A/BS RD FPM 31,5x42x7</p> <p>K:→ 353.840 55555805 SP LD PTFE/ACM 80x98</p> <p>N:← 353.990 55563374 ASW RD FPM 35x48x7 2x</p>	
<p>597.400 12661725 FPM 16x</p> 	<p>693.670 12 673 929</p> 	<p>884.060 12 637 018</p> 	<p>a) 036.164 Dirko HT / EU</p> <p>a) 510.031 Dirko HT / USA/CDN/MEX</p> <p>a) 527.291 Dirko HT / RU</p> <p>a) 648.661 Dirko HT / BR</p> <p>b) 823.400 55 577 568 +12 616 850 M 12x1,75x17</p> <p>b) 056.130 12 616 850 FPM RD 10,8x20,8x2,6</p>	<p>K:← 587.430 12 661 527 A/BS OF RD FPM 44x60x8,5</p> <p>K:→ 481.450 12 653 685 A/BS OF LD FPM 84x100x8,9</p>	<p>TLS 911.180</p>
<p>597.400 12661725 FPM 16x</p> 	<p>886.410 12 643 224</p> 	<p>884.050 12 647 002</p> 	<p>a) 036.164 Dirko HT / EU</p> <p>a) 510.031 Dirko HT / USA/CDN/MEX</p> <p>a) 527.291 Dirko HT / RU</p> <p>a) 648.661 Dirko HT / BR</p> <p>b) 823.400 55 577 568 +12 616 850 M 12x1,75x17</p> <p>b) 056.130 12 616 850 FPM RD 10,8x20,8x2,6</p>	<p>K:← 587.430 12 661 527 A/BS OF RD FPM 44x60x8,5</p> <p>K:→ 481.450 12 653 685 A/BS OF LD FPM 84x100x8,9</p>	
			<p>a) 036.164 Dirko HT / EU</p> <p>a) 510.031 Dirko HT / USA/CDN/MEX</p> <p>a) 527.291 Dirko HT / RU</p> <p>a) 648.661 Dirko HT / BR</p>		

<p>CHEVROLET/ DAEWOO</p> 				
<p>L3A</p> <p>4 Cyl. 1490 ccm Cyl. 74,0 Ø</p> <p>Volt 05/2015 →</p>		<p>259.821 12681524 1,00 mm $\frac{\pm}{\text{mm}}$ 75,2 Ø</p> 	<p>ZKS 940.160 11 548 125 (10x) M 10x1,5x110</p> 	<p>ZKHS 910.680 12 664 830 599.290 12 636 176 2x</p> 
<p>LFV LYX</p> <p>4 Cyl. 1490 ccm Cyl. 74,0 Ø</p> <p>Equinox 07/2017 →</p> <p>Malibu 09/2015 →</p>	<p>ES⊕ 911.980 12 679 878</p> <p>CS* 886.920</p>	<p>259.821 12681524 1,00 mm $\frac{\pm}{\text{mm}}$ 75,2 Ø</p> 	<p>ZKS 940.160 11 548 125 (10x) M 10x1,5x110</p> 	<p>ZKHS 910.680 12 664 830 599.290 12 636 176 2x</p> 
<p>A15MF V15L</p> <p>4 Cyl. 1498 ccm Cyl. 76,5 Ø</p> <p>Aranos 01/1995 → 11/1997</p> <p>Cielo 06/1994 → 07/1998</p> <p>Espero 10/1993 → 06/1999</p> <p>Nexia 02/1995 → 08/1997</p>	<p>CS* 828.620</p>	<p>068.181 96391435 1,70 mm $\frac{\pm}{\text{mm}}$</p> 	<p>ZKS 356.390 94501031 (10x) M 10x1,25x166</p> 	<p>ZKHS 718.890 068.190 96144620</p> 
<p>F15D3</p> <p>4 Cyl. 1498 ccm</p> <p>Lacetti 01/2003 → 12/2005</p>	<p>S⊕* 583.200 →12/2005</p> <p>S⊕* 585.250 01/2006→</p> <p>ES⊕ 584.570 →12/2005</p> <p>ES⊕ 585.260 01/2006→</p>	<p>550.570 ● 96378802 0,65 mm $\frac{\pm}{\text{mm}}$ 80 Ø</p>  <p>1 ▽ →12/2005</p> <p>471.740 96963220 80 Ø</p>  <p>01/2006→</p>	<p>ZKS 356.390 94501031 (10x) M 10x1,25x166</p> 	<p>457.250 96353002</p> <p>PLASTIC</p> 

			<p>a) </p> <p>b) </p>	<p>K: </p> <p>N: </p>	
		<p>884.060 12 637 018</p> 	<p>a) 036.164 Dirko HT / EU</p> <p>a) 510.031 Dirko HT / USA/CDN/MEX</p> <p>a) 527.291 Dirko HT / RU</p> <p>a) 648.661 Dirko HT / BR</p> <p>b) 823.400 55 577 568 +12 616 850 M 12x1,75x17</p> <p>b) 056.130 12 616 850 FPM RD 10,8x20,8x2,6</p>	<p>K:← 587.430 12 661 527 A/BS OF RD FPM 44x60x8,5</p> <p>K:→ 481.450 12 653 685 A/BS OF LD FPM 84x100x8,9</p>	
<p>597.400 12661725 FPM 16x</p> 	<p>693.670 12 673 929</p> 	<p>884.060 12 637 018</p> 	<p>a) 036.164 Dirko HT / EU</p> <p>a) 510.031 Dirko HT / USA/CDN/MEX</p> <p>a) 527.291 Dirko HT / RU</p> <p>a) 648.661 Dirko HT / BR</p> <p>b) 823.400 55 577 568 +12 616 850 M 12x1,75x17</p> <p>b) 056.130 12 616 850 FPM RD 10,8x20,8x2,6</p>	<p>K:← 587.430 12 661 527 A/BS OF RD FPM 44x60x8,5</p> <p>K:→ 481.450 12 653 685 A/BS OF LD FPM 84x100x8,9</p>	<p>TLS 911.180</p>
<p>165.560 96353035 FPM 16x</p>	<p>165.590 96350469</p> 	<p>165.580 96352947</p> 	<p>a) 766.390 90409693 2x</p>  <p>FE</p>  <p>b) 115.100 94525114 CU A 14x20x1,5</p>	<p>K:← 755.141 90501719 ASW RD FPM/ACM 26x42x8</p> <p>K:→ 590.797 96101489 A/BS LD FPM 80x98x10</p> <p>N:← 757.497 94580413 ASW RD FPM 42x56x7 2x</p>	
<p>165.560 96353035 FPM 16x</p>	<p>165.590 96350469</p> 	<p>527.910 96461130 4x</p> 	<p>a) 036.164 Dirko HT / EU</p> <p>a) 510.031 Dirko HT / USA/CDN/MEX</p> <p>a) 527.291 Dirko HT / RU</p> <p>a) 648.661 Dirko HT / BR</p> <p>b) 774.460 94535699 M 14x1,5x11</p> <p>b) 115.100 94525114 CU A 14x20x1,5</p>	<p>K:← 505.838 ASW RD FPM 30x42x7</p> <p>K:← 598.760 96 350 161 AS RD FPM 30x42x8</p> <p>K:→ 590.797 96101489 A/BS LD FPM 80x98x10</p> <p>N:← 757.497 94580413 ASW RD FPM 42x56x7 2x</p>	

**CHEVROLET/
DAEWOO**



			<p>a) </p> <p>b) </p>	<p>K: </p> <p>N: </p>	
<p>VAS 216.730 586.693 94580655 FPM 8x</p>	<p>645.710 96181207 90412459</p> 	<p>919.382 96183118</p> 	<p>a) 036.164 Dirko HT / EU</p> <p>a) 510.031 Dirko HT / USA/CDN/MEX</p> <p>a) 527.291 Dirko HT / RU</p> <p>a) 648.661 Dirko HT / BR</p> <p>b) 774.460 94535699 M 14x1,5x11</p> <p>b) 115.100 94525114 CU A 14x20x1,5</p>	<p>K:← 440.720 96350161 ASW RD ACM 30x42x7</p> <p>K:← 505.838 ASW RD FPM 30x42x7</p> <p>K:→ 590.797 96101489 A/BS LD FPM 80x98x10</p> <p>N:← 702.269 96183314 AW/BS RD VMQ 35x48x7</p>	
<p>VAS 216.730 586.693 94580655 FPM 8x</p>	<p>645.710 96181207 90412459</p> 	<p>919.382 96183118</p> 	<p>a) 036.164 Dirko HT / EU</p> <p>a) 510.031 Dirko HT / USA/CDN/MEX</p> <p>a) 527.291 Dirko HT / RU</p> <p>a) 648.661 Dirko HT / BR</p> <p>b) 774.460 94535699 M 14x1,5x11</p> <p>b) 115.100 94525114 CU A 14x20x1,5</p>	<p>K:← 440.720 96350161 ASW RD ACM 30x42x7</p> <p>K:← 505.838 ASW RD FPM 30x42x7</p> <p>K:→ 590.797 96101489 A/BS LD FPM 80x98x10</p> <p>N:← 702.269 96183314 AW/BS RD VMQ 35x48x7</p>	
<p>VAS 216.730 586.693 94580655 FPM 8x</p>	<p>645.710 96181207 90412459</p> 	<p>919.382 96183118</p> 	<p>a) 036.164 Dirko HT / EU</p> <p>a) 510.031 Dirko HT / USA/CDN/MEX</p> <p>a) 527.291 Dirko HT / RU</p> <p>a) 648.661 Dirko HT / BR</p> <p>a) 766.390 90409693 →07/1997</p>  <p>FE</p>  <p>b) 115.100 94525114 CU A 14x20x1,5</p>	<p>K:← 440.720 96350161 ASW RD ACM 30x42x7</p> <p>K:← 505.838 ASW RD FPM 30x42x7</p> <p>K:← 755.141 90501719 ASW RD FPM/ACM 26x42x8 →07/1997</p> <p>K:→ 590.797 96101489 A/BS LD FPM 80x98x10</p> <p>N:← 702.269 96183314 AW/BS RD VMQ 35x48x7</p>	

**CHEVROLET/
DAEWOO**

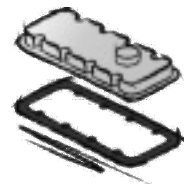
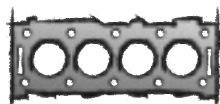
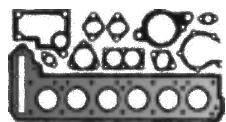

A16DMS

4 Cyl. **1598 ccm**
Cyl. 79,0 Ø

Lacetti

06/1999 → 07/2003

Nubira

04/1997 →

Rezzo

09/2000 →

ES⊕ **454.020**



AL

167.621

96391436

1,40 mm ± 80,5 Ø



ZKS **356.390**

94501031 (10x)

M 10x1,25x166



ZKHS **174.251**

96351213



AL



457.250

96353002



PLASTIC

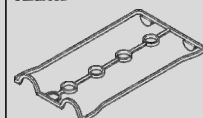

**F16S4
L44(96CUL4)**

4 Cyl. **1598 ccm**
Cyl. 79,0 Ø

Aveo

09/2003 → 12/2008

Chevy

05/2006 →

Kalos

02/2003 →

Lacetti

03/2005 →

Lanos

11/2005 → 12/2010

Nubira

03/2005 → 12/2011

Optra

08/2003 → 12/2008

Rezzo

08/2001 →

Vivant

08/2001 →

S⊕* **585.250**

ES⊕ **585.260**

471.740

96963220

80 Ø



ZKS **356.390**

94501031 (10x)

M 10x1,25x166



457.250

96353002



PLASTIC

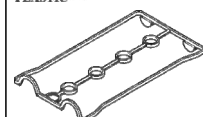

L44(98CUL4)

4 Cyl. **1598 ccm**
Cyl. 79,0 Ø

Lanos

02/1997 →

ES⊕ **454.020**



AL

167.621

96391436

1,40 mm ± 80,5 Ø



ZKS **356.390**

94501031 (10x)

M 10x1,25x166



ZKHS **174.251**

96351213

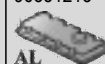

AL

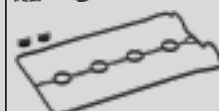









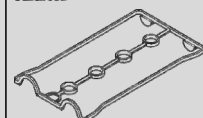





457.250











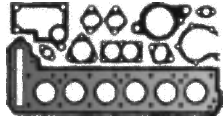
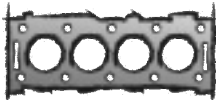

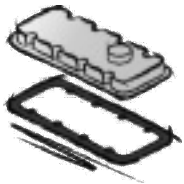



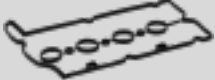

96353002

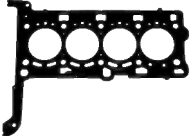
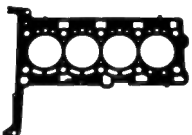
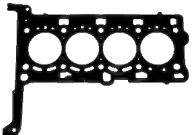







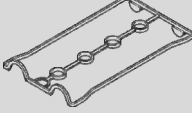









PLASTIC



			<p>a) </p> <p>b) </p>	<p>K: </p> <p>N: </p>	
<p>165.560 96353035 FPM 16x</p>	<p>165.590 96350469</p> 	<p>165.580 96352947</p> 	<p>a) 036.164 Dirko HT / EU</p> <p>a) 510.031 Dirko HT / USA/CDN/MEX</p> <p>a) 527.291 Dirko HT / RU</p> <p>a) 648.661 Dirko HT / BR</p> <p>b) 774.460 94535699 M 14x1,5x11</p> <p>b) 115.100 94525114 CU A 14x20x1,5</p>	<p>K:← 440.720 96350161 ASW RD ACM 30x42x7</p> <p>K:← 505.838 ASW RD FPM 30x42x7</p> <p>K:→ 590.797 96101489 A/BS LD FPM 80x98x10</p> <p>N:← 757.497 94580413 ASW RD FPM 42x56x7 2x</p>	
<p>165.560 96353035 FPM 16x</p>	<p>165.590 96350469</p> 	<p>527.910 96461130 4x</p> 	<p>a) 036.164 Dirko HT / EU</p> <p>a) 510.031 Dirko HT / USA/CDN/MEX</p> <p>a) 527.291 Dirko HT / RU</p> <p>a) 648.661 Dirko HT / BR</p> <p>b) 774.460 94535699 M 14x1,5x11</p> <p>b) 115.100 94525114 CU A 14x20x1,5</p>	<p>K:← 505.838 ASW RD FPM 30x42x7</p> <p>K:← 598.760 96 350 161 AS RD FPM 30x42x8</p> <p>K:→ 590.797 96101489 A/BS LD FPM 80x98x10</p> <p>N:← 757.497 94580413 ASW RD FPM 42x56x7 2x</p>	
<p>165.560 96353035 FPM 16x</p>	<p>165.590 96350469</p> 	<p>165.580 96352947 →12/2002</p> 	<p>a) 036.164 Dirko HT / EU</p> <p>a) 510.031 Dirko HT / USA/CDN/MEX</p> <p>a) 527.291 Dirko HT / RU</p> <p>a) 648.661 Dirko HT / BR</p> <p>b) 774.460 94535699 M 14x1,5x11</p> <p>b) 115.100 94525114 CU A 14x20x1,5</p>	<p>K:← 440.720 96350161 ASW RD ACM 30x42x7</p> <p>K:← 505.838 ASW RD FPM 30x42x7</p> <p>K:→ 590.797 96101489 A/BS LD FPM 80x98x10</p> <p>N:← 757.497 94580413 ASW RD FPM 42x56x7 2x</p>	

<p>CHEVROLET/ DAEWOO</p> 				
<p>LDE LFJ</p> <p>4 Cyl. 1598 ccm Cyl. 79,0 Ø</p> <p>Aveo 03/2011 →</p> <p>Cruze 05/2009 →</p> <p>Trax 12/2012 →</p>	<p>ES⊕ 504.200 93190885</p> <p>CS* 539.690 55568528</p> <p>OKS 599.160</p> 	<p>076.892 93186222</p> <p>0,65 mm $\frac{\pm}{\pm}$ 81,7 Ø</p> 	<p>ZKS 803.060 90412701(10x) M 10x1,25x153</p> 	<p>354.030 55354237</p> 
<p>LH7(98CUL4) LVL LWQ LWV</p> <p>4 Cyl. 1598 ccm Cyl. 79,7 Ø</p> <p>Cruze 01/2017 →</p> <p>Equinox 03/2017 → 12/2019</p> <p>Trax 11/2014 → 12/2015</p>	<p>ES⊕ 847.000</p>  <p>CS* 810.350</p> <p>OKS 980.870</p>	<p>744.472 55 590 777</p> <p> 0,440 mm → 0,535 mm</p> <p>1,25 mm $\frac{\pm}{\pm}$ 81 Ø</p> <p>744.482 55 590 776</p> <p> 0,535 mm → 0,630 mm</p> <p>1,35 mm $\frac{\pm}{\pm}$ 81 Ø</p> <p>744.492 55 590 778</p> <p> 0,630 mm → 0,725 mm</p> <p>1,45 mm $\frac{\pm}{\pm}$ 81 Ø</p>   	<p>ZKS 659.500 55 598 493 (10x) M 12x1,75x196,6</p> 	<p>ZKHS 812.200</p>  <p>811.670 55 571 587</p>  <p>560.370 55 578 373 4x</p> <p>560.490 55 574 959 16x</p> 
<p>F16D3 LXT</p> <p>4 Cyl. 1598 ccm Cyl. 79,0 Ø</p> <p>Aveo 01/2007 →</p> <p>Cruze 05/2009 →</p> <p>Genra 05/2005 →</p> <p>Lacetti 02/2004 →</p> <p>Nexia 07/2008 →</p> <p>Nubira 07/2003 →</p> <p>Optra 08/2003 →</p>	<p>S⊕* 583.200 →12/2005</p> <p>S⊕* 585.250 01/2006→</p> <p>ES⊕ 584.570 →12/2005</p> <p>ES⊕ 585.260 01/2006→</p>	<p>550.570 ● 96378802</p> <p>0,65 mm $\frac{\pm}{\pm}$ 80 Ø</p> <p>1 ▽ →12/2005</p> <p>471.740 96963220</p> <p>80 Ø</p>  	<p>ZKS 356.390 94501031 (10x) M 10x1,25x166</p> 	<p>457.250 96353002</p>  <p>PLASTIC</p> 

			<p>a) </p> <p>b) </p>	<p>K: </p> <p>N: </p>	
<p>061.760 24405819 FPM 16x</p>	<p>355.340 12992396</p> 	<p>504.260 55559374</p> 	<p>a) 036.164 Dirko HT / EU</p> <p>a) 510.031 Dirko HT / USA/CDN/MEX</p> <p>a) 527.291 Dirko HT / RU</p> <p>a) 648.661 Dirko HT / BR</p> <p>b) 274.410 96 023 264 M 14x1,5x13,5</p> <p>b) 476.750 90 528 145 FPM RD 18x22x2</p>	<p>K:← 056.900 24465791 A/BS RD FPM 31,5x42x7</p> <p>K:→ 353.840 55555805 SP LD PTFE/ACM 80x98</p> <p>N:← 353.990 55563374 ASW RD FPM 35x48x7 2x</p>	
<p>562.100 55 569 928 FPM 16x</p> 	<p>894.772 55 496 050</p>	<p>558.460 55 577 046</p> 	<p>a) 036.164 Dirko HT / EU</p> <p>a) 510.031 Dirko HT / USA/CDN/MEX</p> <p>a) 527.291 Dirko HT / RU</p> <p>a) 560.760 55 573 794</p>  <p>a) 648.661 Dirko HT / BR</p>	<p>K:← 562.000 55 596 779 A/BS OF RD FPM 53x72x9</p> <p>K:→ 561.960 55 571 582 AW/BS OF LD FPM 92x109x9</p>	<p>TLS 812.170</p> 
<p>165.560 96353035 FPM 16x</p>	<p>165.590 96350469</p> 	<p>527.910 96461130 4x</p> 	<p>a) 036.164 Dirko HT / EU</p> <p>a) 510.031 Dirko HT / USA/CDN/MEX</p> <p>a) 527.291 Dirko HT / RU</p> <p>a) 648.661 Dirko HT / BR</p> <p>b) 774.460 94535699 M 14x1,5x11</p> <p>b) 115.100 94525114 CU A 14x20x1,5</p>	<p>K:← 505.838 ASW RD FPM 30x42x7</p> <p>K:← 598.760 96 350 161 AS RD FPM 30x42x8</p> <p>K:→ 590.797 96101489 A/BS LD FPM 80x98x10</p> <p>N:← 757.497 94580413 ASW RD FPM 42x56x7 2x</p>	

**CHEVROLET/
DAEWOO**

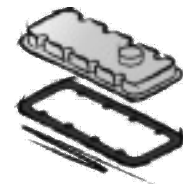
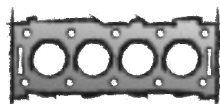
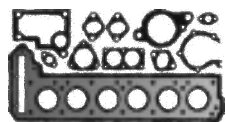

LXV
4 Cyl. **1598 ccm**
Cyl. 79,0 Ø

Aveo
05/2005 →

Lacetti
02/2009 → 02/2011

Nexia
08/1997 → 06/2008

ES⊕ **504.200**
93190885

CS* **545.820**
93190886
→07/2007

CS* **539.690**
55568528
08/2007→

OKS **599.160**
08/2007→



076.892
93186222
0,65 mm $\frac{\pm}{\text{mm}}$ 81,7 Ø



ZKS **803.060**
90412701(10x)
M 10x1,25x153



354.030
55354237

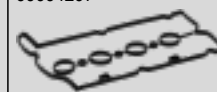

**LKR
LUD**
4 Cyl. **1686 ccm**
Cyl. 79,0 Ø

Cruze
01/2012 →

Trax
12/2012 →

ES⊕ **367.050**

CS* **724.360**



158.352
97376212
0,95 mm $\frac{\pm}{\text{mm}}$
1 ▽



158.382
97376213
1,00 mm $\frac{\pm}{\text{mm}}$
2 ▽



158.412
97376214
1,05 mm $\frac{\pm}{\text{mm}}$
3 ▽



477.390
98014758

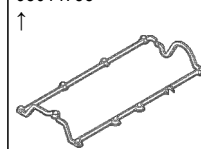

809.400
97313965



18N
4 Cyl. **1796 ccm**
Cyl. 84,8 Ø

Monza
02/1994 → 09/2002

**2H0 F18D4
LFH LUW
LWE**
4 Cyl. **1796 ccm**
Cyl. 80,5 Ø

Astra
01/2006 → 12/2013

Aveo
09/2011 →

Cruze
05/2009 →

Lacetti
02/2009 → 02/2011

Orlando
02/2011 →

Trax
03/2013 →

ES⊕ **354.010**
93186911

CS* **353.830**
93186910

OKS **599.160**



076.892
93186222
0,65 mm $\frac{\pm}{\text{mm}}$ 81,7 Ø



























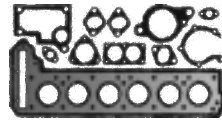
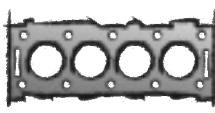

ZKS **803.060**
90412701(10x)
M 10x1,25x153

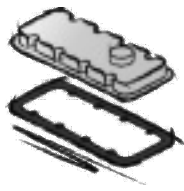

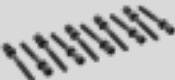

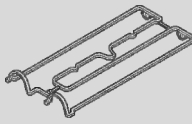

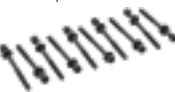
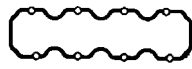

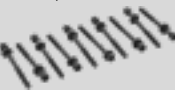
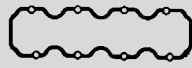









354.030
55354237

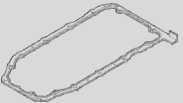

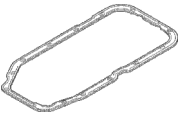







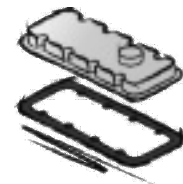
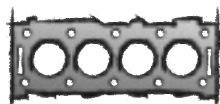
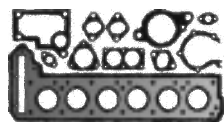









			<p>a) </p> <p>b) </p>	<p>K: </p> <p>N: </p>	
<p>061.760 24405819 FPM 16x</p>	<p>355.340 12992396</p> 	<p>504.260 55559374</p> 	<p>a) 036.164 Dirko HT / EU</p> <p>a) 510.031 Dirko HT / USA/CDN/MEX</p> <p>a) 527.291 Dirko HT / RU</p> <p>a) 648.661 Dirko HT / BR</p> <p>b) 274.410 96 023 264 M 14x1,5x13,5</p> <p>b) 476.750 90 528 145 FPM RD 18x22x2</p>	<p>K:← 056.900 24465791 A/BS RD FPM 31,5x42x7</p> <p>K:→ 353.840 55555805 SP LD PTFE/ACM 80x98</p> <p>N:← 353.990 55563374 ASW RD FPM 35x48x7 2x</p>	
<p>VAS 424.800 FPM</p> <p>403.730 90410741 FPM 16x</p>	<p>076.971 97385827 2x</p> 	<p>366.940 55571946</p> 	<p>a) 036.164 Dirko HT / EU</p> <p>a) 510.031 Dirko HT / USA/CDN/MEX</p> <p>a) 527.291 Dirko HT / RU</p> <p>a) 648.661 Dirko HT / BR</p> <p>b) 274.410 96 023 264 M 14x1,5x13,5</p> <p>b) 476.750 90 528 145 FPM RD 18x22x2</p>	<p>K:← 854.180 AS RD FPM 40x52x6</p> <p>K:→ 733.070 94327063 AS LD FPM 87x100x8</p> <p>N:← 763.918 90322669 AW/BS RD FPM 38x50x8</p>	<p>TLS 895.670</p> 
			<p>b) 773.630 90 409 376 M 14x1,5x12</p>		
<p>061.760 24405819 FPM 16x</p>	<p>355.340 12992396</p> 	<p>AAS 207.210</p>  <p>434.350 93185729</p> 	<p>a) 036.164 Dirko HT / EU</p> <p>a) 510.031 Dirko HT / USA/CDN/MEX</p> <p>a) 527.291 Dirko HT / RU</p> <p>a) 648.661 Dirko HT / BR</p> <p>b) 274.410 96 023 264 M 14x1,5x13,5</p> <p>b) 587.880 55 568 037 M 14x1,5x16</p> <p>b) 476.750 90 528 145 FPM RD 18x22x2</p>	<p>K:← 056.900 24465791 A/BS RD FPM 31,5x42x7</p> <p>K:→ 353.840 55555805 SP LD PTFE/ACM 80x98</p> <p>N:← 353.990 55563374 ASW RD FPM 35x48x7 2x</p>	

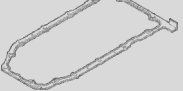









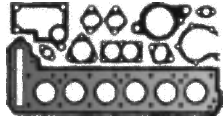
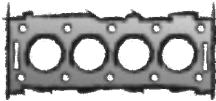

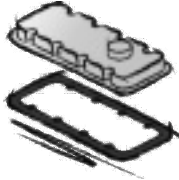

<p>CHEVROLET/ DAEWOO</p> 				
<p>L84(110CUL4)</p> <p>4 Cyl. 1796 ccm Cyl. 84,8 Ø</p> <p>Nubira 04/1997 → 05/1999</p>	<p>CS* 712.480 92061971</p>	<p>645.842 90411937 1,30 mm $\frac{1}{2}$ 83 Ø</p> 	<p>ZKS 803.010 90466480 (10x) M 11x1,25x105</p> 	<p>ZKHS 058.880</p>  <p>495.770 90501944</p>  <p>212.610 90411826 10x</p> 
<p>C 18 NE C18LE LC5(110CUL4) Y18L</p> <p>4 Cyl. 1796 ccm Cyl. 84,8 Ø</p> <p>Aranos 01/1995 → 11/1997</p> <p>Astra 09/1998 → 12/2011</p> <p>Corsa 08/2002 →</p> <p>Espero 02/1995 → 09/1999</p> <p>Leganza 06/1997 → 07/2003</p> <p>Meriva 02/2002 → 07/2012</p> <p>Nexia 02/1995 → 06/2008</p> <p>Nubira 06/2004 →</p> <p>Prince 08/1993 → 08/1998</p>	<p>ES⊕ 702.367 90397808</p> <p>CS* 702.294 90397689</p>	<p>828.913 90409570 1,30 mm $\frac{1}{2}$ 86,3 Ø</p> 	<p>ZKS 820.458 90444861 (10x) M 11x1,25x140</p> 	<p>827.843 638192</p> 
<p>S 18 NV</p> <p>4 Cyl. 1796 ccm Cyl. 84,8 Ø</p> <p>Prince 08/1990 → 08/1997</p> <p>Super Saloon 08/1992 → 08/1995</p>	<p>ES⊕ 702.286 CS* 702.294 90397689</p>	<p>828.913 90409570 1,30 mm $\frac{1}{2}$ 86,3 Ø</p> 	<p>ZKS 820.458 90444861 (10x) M 11x1,25x140</p> 	<p>827.843 638192</p> 













			<p>a) </p> <p>b) </p>	<p>K: </p> <p>N: </p>	
<p>VAS 424.800 FPM 403.730 90410741 FPM 16x</p>	<p>735.370 92063157 </p>	<p>645.910 90412459 </p>	<p>a) 410.050 90467759 ↑ </p> <p>b) 115.100 94525114 CU A 14x20x1,5</p>	<p>K:← 330.736 92060272 AW/BS RD FPM 31x50x8 K:→ 694.770 90354378 ASW LD FPM/ACM 90x104x11 N:← 702.269 96183314 AW/BS RD VMQ 35x48x7 2x</p>	
<p>VAS 216.730 586.693 94580655 FPM 8x</p>	<p>768.104 90409644 </p>	<p>834.262 92060514 90200921 </p>	<p>a) 702.331 90194295 </p> <p>b) 773.630 90 409 376 M 14x1,5x12</p> <p>b) 115.100 94525114 CU A 14x20x1,5</p>	<p>K:← 330.736 92060272 AW/BS RD FPM 31x50x8 K:→ 694.770 90354378 ASW LD FPM/ACM 90x104x11 N:← 702.269 96183314 AW/BS RD VMQ 35x48x7 N:→ 694.711 90325573 ASW LD FPM/ACM 55x70x8</p>	
<p>VAS 216.730 586.693 94580655 FPM 8x</p>	<p>768.104 90409644 </p>	<p>829.323 90351504 </p>	<p>a) 702.331 90194295 </p> <p>b) 773.630 90 409 376 M 14x1,5x12</p> <p>b) 115.100 94525114 CU A 14x20x1,5</p>	<p>K:← 330.736 92060272 AW/BS RD FPM 31x50x8 K:→ 694.770 90354378 ASW LD FPM/ACM 90x104x11 N:← 702.269 96183314 AW/BS RD VMQ 35x48x7 N:→ 694.711 90325573 ASW LD FPM/ACM 55x70x8</p>	

**CHEVROLET/
DAEWOO**



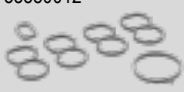

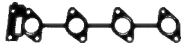





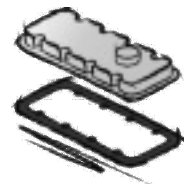
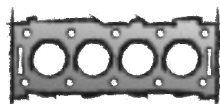
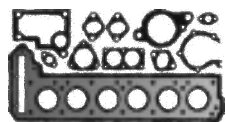







			<p>a) </p> <p>b) </p>	<p>K: </p> <p>N: </p>	
<p>VAS 424.800 FPM 403.730 90410741 FPM 16x</p>	<p>735.370 92063157 </p>	<p>645.910 90412459 </p>	<p>a) 410.050 90467759 ↑ </p> <p>b) 115.100 94525114 CU A 14x20x1,5</p>	<p>K:← 330.736 92060272 AW/BS RD FPM 31x50x8 K:→ 694.770 90354378 ASW LD FPM/ACM 90x104x11 N:← 702.269 96183314 AW/BS RD VMQ 35x48x7 2x</p>	
<p>506.550 55 183 812 FPM 16x</p>	<p>743.450 55566281 </p>	<p>AAS 340.470 55580012 </p>	<p>a) 036.164 Dirko HT / EU a) 510.031 Dirko HT / USA/CDN/MEX a) 527.291 Dirko HT / RU a) 648.661 Dirko HT / BR b) 359.300 FPM A 18x26x1,5 FE/FPM</p>	<p>K:← 069.590 93180737 AW/BS RD FPM 31x41x7 K:→ 199.191 93178503 SP LD FPM 93x12 N:← 434.500 93178980 A/BS RD FPM 30x45x7 N:← 993.440 55 574 601 ASW OF RD FPM 30x50x7</p>	<p>TLS 897.840 </p>
<p>633.550 55 578 160 FPM 16x </p>	<p>590.410 55 486 632 </p>	<p>633.230 55 580 111 </p>	<p>a) 036.164 Dirko HT / EU a) 510.031 Dirko HT / USA/CDN/MEX a) 527.291 Dirko HT / RU a) 648.661 Dirko HT / BR b) 823.400 55 577 568 +12 616 850 M 12x1,75x17 b) 056.130 12 616 850 FPM RD 10,8x20,8x2,6</p>	<p>K:→ 773.440 55 485 582 SP LD FPM 93 N:← 592.400 55 580 121 AW/BS RD FPM 22,6x45,3x7,1</p>	<p>TLS 796.490 </p>

<p>CHEVROLET/ DAEWOO</p> 				
<p>LUZ</p> <p>4 Cyl. 1956 ccm Cyl. 83,0 Ø</p> <p>Cruze CDI 09/2013 →</p>	<p>ES⊕ 789.720</p>  <p>CS* 898.130</p>	<p>457.812 55574904</p>  <p>0,110 mm → 0,230 mm</p> <p>0,95 mm $\frac{\text{mm}}{2}$</p> <p>457.822 55574905</p>  <p>0,231 mm → 0,330 mm</p> <p>1,05 mm $\frac{\text{mm}}{2}$ 1 ⊗</p> <p>457.832 55574906</p>  <p>0,331 mm → 0,425 mm</p> <p>1,15 mm $\frac{\text{mm}}{2}$ 2 ⊗</p>	<p>ZKS 642.100 M 12x1,25x224,5</p> 	<p>743.381 55577629</p> 
<p>LLW LMN Z 20 DM/DMH/S/S1</p> <p>4 Cyl. 1991 ccm Cyl. 83,0 Ø</p> <p>Captiva 07/2006 →</p> <p>Cruze CDI 05/2009 →</p> <p>Epica 01/2007 → 12/2011</p> <p>Lacetti 01/2007 →</p> <p>Nubira 01/2005 → 12/2011</p> <p>Optra 12/2008 → 11/2012</p> <p>Tosca 02/2006 →</p> <p>Winstorm 01/2007 → 02/2011</p>	<p>ES⊕ 736.630</p>  <p>CS* 690.500</p>	<p>531.450 96440163</p> <p>1,10 mm $\frac{\text{mm}}{2}$ 84 Ø </p> <p>1 ∇</p> <p>531.460 96440164</p> <p>1,20 mm $\frac{\text{mm}}{2}$ 84 Ø </p> <p>2 ∇</p> <p>531.470 96440165</p> <p>1,30 mm $\frac{\text{mm}}{2}$ 84 Ø </p> <p>3 ∇</p>		<p>539.440 96440309</p> 

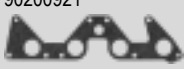
			<p>a) </p> <p>b) </p>	<p>K: </p> <p>N: </p>	
<p>506.550 55 183 812 FPM 16x</p>	<p>743.450 55566281</p> 	<p>AAS 340.470 55580012</p> 	<p>a) 036.164 Dirko HT / EU</p> <p>a) 510.031 Dirko HT / USA/CDN/MEX</p> <p>a) 527.291 Dirko HT / RU</p> <p>a) 648.661 Dirko HT / BR</p> <p>b) 359.300 FPM A 18x26x1,5 FE/FPM</p>	<p>K:← 069.590 93180737 AW/BS RD FPM 31x41x7</p> <p>K:→ 199.191 93178503 SP LD FPM 93x12</p> <p>N:← 434.500 93178980 A/BS RD FPM 30x45x7</p>	<p>TLS 897.840</p> 
<p>574.330 96440146 FPM 16x</p>	<p>584.280 96440364</p> 	<p>373.580 96440379</p> 	<p>a) 036.164 Dirko HT / EU</p> <p>a) 510.031 Dirko HT / USA/CDN/MEX</p> <p>a) 527.291 Dirko HT / RU</p> <p>a) 648.661 Dirko HT / BR</p> <p>b) 774.460 94535699 M 14x1,5x11</p> <p>b) 115.100 94525114 CU A 14x20x1,5</p>	<p>K:← 583.050 96440222 AS RD FPM 32x45x6</p> <p>K:→ 584.930 96440233 AS LD FPM 98x114x8</p> <p>N:← 583.030 96440161 AS RD FPM 36x50x8</p>	



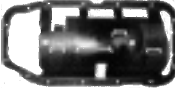

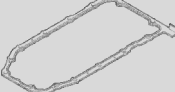



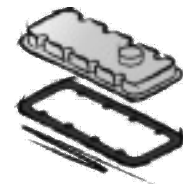
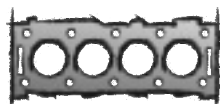
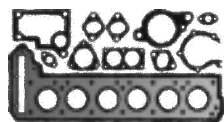









**CHEVROLET/
DAEWOO**

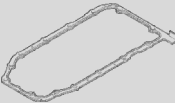









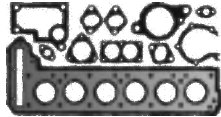
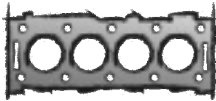

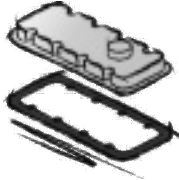



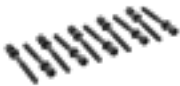



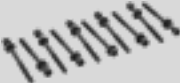
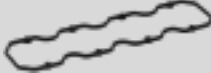







			<p>a) </p> <p>b) </p>	<p>K: </p> <p>N: </p>	
<p>VAS 216.730 586.693 94580655 FPM 8x</p>	<p>768.104 90409644</p> 	<p>834.262 92060514 90200921</p> 	<p>a) 164.341 92061327</p>  <p>a) 702.331 90194295</p>  <p>b) 773.630 90 409 376 M 14x1,5x12</p> <p>b) 115.100 94525114 CU A 14x20x1,5</p>	<p>K:← 330.736 92060272 AW/BS RD FPM 31x50x8</p> <p>K:→ 694.770 90354378 ASW LD FPM/ACM 90x104x11</p> <p>N:← 702.269 96183314 AW/BS RD VMQ 35x48x7</p> <p>N:→ 694.711 90325573 ASW LD FPM/ACM 55x70x8</p>	
<p>VAS 216.730 586.693 94580655 FPM 8x</p>	<p>768.104 90409644</p> 		<p>a) 164.341 92061327</p>  <p>b) 773.630 90 409 376 M 14x1,5x12</p> <p>b) 115.100 94525114 CU A 14x20x1,5</p>	<p>K:← 330.736 92060272 AW/BS RD FPM 31x50x8</p> <p>K:→ 694.770 90354378 ASW LD FPM/ACM 90x104x11</p> <p>N:← 702.269 96183314 AW/BS RD VMQ 35x48x7</p> <p>N:→ 694.711 90325573 ASW LD FPM/ACM 55x70x8</p>	
<p>VAS 424.800 FPM 403.730 90410741 FPM 16x</p>	<p>735.370 92063157</p> 	<p>645.910 90412459</p> 	<p>a) 410.050 90467759 ↑</p>  <p>b) 773.630 90 409 376 M 14x1,5x12</p> <p>b) 115.100 94525114 CU A 14x20x1,5</p>	<p>K:← 330.736 92060272 AW/BS RD FPM 31x50x8</p> <p>K:→ 694.770 90354378 ASW LD FPM/ACM 90x104x11</p> <p>N:← 702.269 96183314 AW/BS RD VMQ 35x48x7 2x</p>	

**CHEVROLET/
DAEWOO**











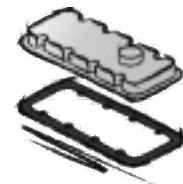
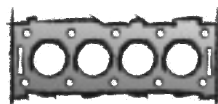
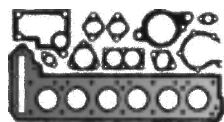







			<p>a) </p> <p>b) </p>	<p>K: </p> <p>N: </p>	
<p>VAS 424.800 FPM 403.730 90410741 FPM 16x</p>	<p>834.793 90411887</p> 	<p>645.910 90412459</p> 	<p>a) 410.050 90467759 ↑ </p> <p>b) 773.630 90 409 376 M 14x1,5x12</p> <p>b) 774.460 94535699 M 14x1,5x11</p> <p>b) 115.100 94525114 CU A 14x20x1,5</p>	<p>K:← 330.736 92060272 AW/BS RD FPM 31x50x8</p> <p>K:→ 694.770 90354378 ASW LD FPM/ACM 90x104x11</p> <p>N:← 702.269 96183314 AW/BS RD VMQ 35x48x7 2x</p>	
<p>VAS 538.080 FPM 007.030 90537241 FPM 16x</p> 	<p>493.940 12622668</p> 	<p>558.510 12589366</p> 	<p>a) 036.164 Dirko HT / EU</p> <p>a) 510.031 Dirko HT / USA/CDN/MEX</p> <p>a) 527.291 Dirko HT / RU</p> <p>a) 648.661 Dirko HT / BR</p> <p>b) 823.400 55 577 568 +12 616 850 M 12x1,75x17</p> <p>b) 056.130 12 616 850 FPM RD 10,8x20,8x2,6</p>	<p>K:← 127.610 90571925 ASW RD FPM/ACM 42x55x7</p> <p>K:← 595.170 12584041 AW/BS OF RD FPM 42x55x7</p> <p>K:→ 441.170 12591866 ASW OF LD FPM 90x104x11</p>	<p>TLS 927.570</p>
<p>VAS 538.080 FPM 007.030 90537241 FPM 16x</p> 	<p>067.920 12 786 717</p> 	<p>067.910 12 786 262</p> 	<p>a) 036.164 Dirko HT / EU</p> <p>a) 510.031 Dirko HT / USA/CDN/MEX</p> <p>a) 527.291 Dirko HT / RU</p> <p>a) 648.661 Dirko HT / BR</p> <p>b) 823.400 55 577 568 +12 616 850 M 12x1,75x17</p> <p>b) 056.130 12 616 850 FPM RD 10,8x20,8x2,6</p>	<p>K:← 127.610 90571925 ASW RD FPM/ACM 42x55x7</p> <p>K:← 595.170 12584041 AW/BS OF RD FPM 42x55x7</p> <p>K:→ 694.770 90354378 ASW LD FPM/ACM 90x104x11</p>	<p>TLS 746.450</p> 



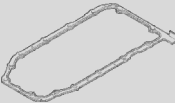





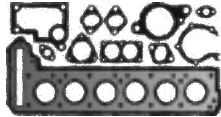
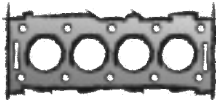

<p>CHEVROLET/ DAEWOO</p> 				
<p>LTG</p> <p>4 Cyl. 1998 ccm Cyl. 86,0 Ø</p> <p>Camaro 09/2015 →</p> <p>Equinox 03/2017 →</p> <p>Malibu 01/2012 →</p> <p>Traverse 07/2017 →</p>	<p>ES⊕ 065.730 CS* 935.740</p>	<p>766.540 12629404</p> <p>88 Ø</p>	<p>ZKS 821.950 11610687 (10x) M 11x2,0x165</p> 	<p>ZKHS 927.920</p> <p>812.030 12635953</p> <p>912.510 12613249 4x</p> 
<p>T20SED</p> <p>4 Cyl. 1998 ccm Cyl. 86,0 Ø</p> <p>Leganza 07/2000 → 04/2004</p> <p>Nubira 12/2000 →</p> <p>Rezzo 09/2000 →</p>	<p>CS* 712.480 92061971</p>	<p>467.593 09129040 1,30 mm $\frac{1}{2}$ 87 Ø</p> 	<p>ZKS 803.010 90466480 (10x) M 11x1,25x105</p> 	<p>ZKHS 058.880</p> <p>495.770 90501944</p>  <p>212.610 90411826 10x</p> 
<p>X 20 SE</p> <p>4 Cyl. 1998 ccm Cyl. 86,0 Ø</p> <p>Nubira 09/1998 → 12/2002</p>	<p>ES⊕ 010.350 CS* 164.350</p>  <p>FE</p>	<p>646.370 92060517 1,30 mm $\frac{1}{2}$ 87,5 Ø</p> 	<p>ZKS 820.458 90444861 (10x) M 11x1,25x140</p> 	<p>023.990 90467661</p> 

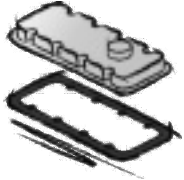
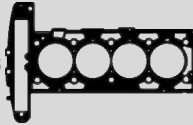

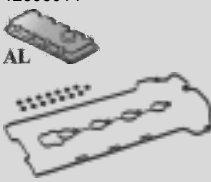

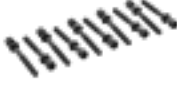
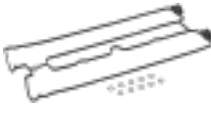

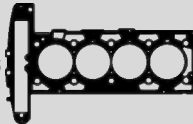

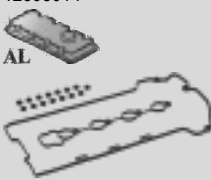





			<p>a) </p> <p>b) </p>	<p>K: </p> <p>N: </p>	
<p>659.440 19207664 FPM E 8x</p> 	<p>941.640 12 657 167</p> 	<p>564.350 12655276</p> 	<p>a) 036.164 Dirko HT / EU</p> <p>a) 510.031 Dirko HT / USA/CDN/MEX</p> <p>a) 527.291 Dirko HT / RU</p> <p>a) 648.661 Dirko HT / BR</p> <p>b) 823.400 55 577 568 +12 616 850 M 12x1,75x17</p> <p>b) 056.130 12 616 850 FPM RD 10,8x20,8x2,6</p>	<p>K:← 562.090 12626923 AW/BS OF RD FPM 44,8x61x9</p> <p>K:→ 441.170 12591866 ASW OF LD FPM 90x104x11</p>	<p>TLS 938.990</p>
<p>VAS 424.800 FPM</p> <p>403.730 90410741 FPM 16x</p>		<p>645.910 90412459</p> 	<p>a) 410.050 90467759</p> <p>↑</p>  <p>b) 774.460 94535699 M 14x1,5x11</p> <p>b) 115.100 94525114 CU A 14x20x1,5</p>	<p>K:← 330.736 92060272 AW/BS RD FPM 31x50x8</p> <p>K:→ 694.770 90354378 ASW LD FPM/ACM 90x104x11</p> <p>N:← 702.269 96183314 AW/BS RD VMQ 35x48x7 2x</p>	
<p>VAS 216.730</p> <p>586.693 94580655 FPM 8x</p>	<p>768.104 90409644</p> 	<p>834.262 92060514 90200921</p> 	<p>a) 164.341 92061327</p>  <p>b) 773.630 90 409 376 M 14x1,5x12</p> <p>b) 115.100 94525114 CU A 14x20x1,5</p>	<p>K:← 330.736 92060272 AW/BS RD FPM 31x50x8</p> <p>K:→ 694.770 90354378 ASW LD FPM/ACM 90x104x11</p> <p>N:← 702.269 96183314 AW/BS RD VMQ 35x48x7</p>	









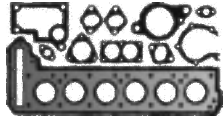
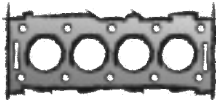

**CHEVROLET/
DAEWOO**

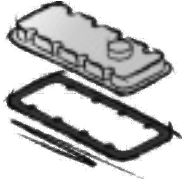
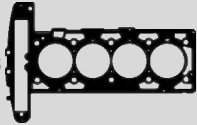

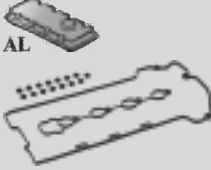
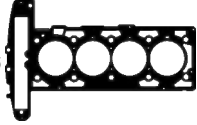

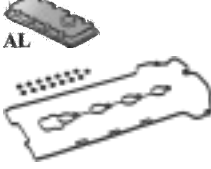
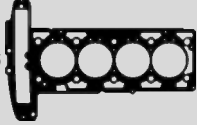

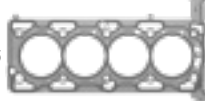











			<p>a) </p> <p>b) </p>	<p>K: </p> <p>N: </p>	
<p>VAS 424.800 FPM 403.730 90410741 FPM 16x</p>	<p>834.793 90411887</p> 	<p>645.910 90412459</p> 	<p>a) 410.050 90467759 ↑ </p> <p>b) 774.460 94535699 M 14x1,5x11</p> <p>b) 115.100 94525114 CU A 14x20x1,5</p>	<p>K:← 330.736 92060272 AW/BS RD FPM 31x50x8</p> <p>K:→ 694.770 90354378 ASW LD FPM/ACM 90x104x11</p> <p>N:← 702.269 96183314 AW/BS RD VMQ 35x48x7 2x</p>	
<p>VAS 538.080 FPM 007.030 90537241 FPM 16x</p> 	<p>493.940 12622668</p>  <p>855.200 12589453</p> 	<p>AAS 483.770 24455111</p>	<p>a) 036.164 Dirko HT / EU</p> <p>a) 510.031 Dirko HT / USA/CDN/MEX</p> <p>a) 527.291 Dirko HT / RU</p> <p>a) 648.661 Dirko HT / BR</p> <p>b) 823.400 55 577 568 +12 616 850 M 12x1,75x17</p> <p>b) 056.130 12 616 850 FPM RD 10,8x20,8x2,6</p>	<p>K:← 127.610 90571925 ASW RD FPM/ACM 42x55x7</p> <p>K:← 595.170 12584041 AW/BS OF RD FPM 42x55x7</p> <p>K:→ 441.170 12591866 ASW OF LD FPM 90x104x11</p> <p>K:→ 694.770 90354378 ASW LD FPM/ACM 90x104x11</p>	
<p>VAS 538.080 FPM 007.030 90537241 FPM 16x</p> 	<p>493.940 12622668</p> 		<p>a) 036.164 Dirko HT / EU</p> <p>a) 510.031 Dirko HT / USA/CDN/MEX</p> <p>a) 527.291 Dirko HT / RU</p> <p>a) 648.661 Dirko HT / BR</p> <p>b) 823.400 55 577 568 +12 616 850 M 12x1,75x17</p> <p>b) 056.130 12 616 850 FPM RD 10,8x20,8x2,6</p>	<p>K:← 127.610 90571925 ASW RD FPM/ACM 42x55x7</p> <p>K:← 595.170 12584041 AW/BS OF RD FPM 42x55x7</p> <p>K:→ 441.170 12591866 ASW OF LD FPM 90x104x11</p>	

<p>CHEVROLET/ DAEWOO</p> 				
<p>LE8(134CUL4)</p> <p>4 Cyl. 2198 ccm Cyl. 86,0 Ø</p> <p>HHR 09/2008 → 12/2011</p>	<p>ES⊕ 558.880</p>	<p>167.911 12 597 769 0,64 mm $\frac{1}{16}$ 89,4 Ø</p> 	<p>ZKS 257.910 90537691 (10x) M 11x1,5x162</p>  <p>ZKS 509.710 90 537 691 (10x) 24407225 (4x) M 11x1,5x162 / M 8</p> 	<p>ZKHS 483.780 12598014</p>  <p>AL</p>
<p>T22SED</p> <p>4 Cyl. 2198 ccm Cyl. 86,0 Ø</p> <p>Leganza 04/1999 → 12/2002</p>	<p>CS* 712.480 92061971</p>	<p>467.593 09129040 1,30 mm $\frac{1}{8}$ 87 Ø</p> 	<p>ZKS 803.010 90466480 (10x) M 11x1,25x105</p> 	<p>ZKHS 058.880</p>  <p>495.770 90501944</p>  <p>212.610 90411826 10x</p> 
<p>LAT</p> <p>4 Cyl. 2384 ccm Cyl. 88,0 Ø</p> <p>Malibu 01/2008 → 12/2010</p>	<p>ES⊕ 558.880 CS* 483.740</p>	<p>167.911 12 597 769 0,64 mm $\frac{1}{16}$ 89,4 Ø</p> 	<p>ZKS 257.910 90537691 (10x) M 11x1,5x162</p>  <p>ZKS 509.710 90 537 691 (10x) 24407225 (4x) M 11x1,5x162 / M 8</p> 	<p>ZKHS 483.780 12598014</p>  <p>AL</p>

			<p>a) </p> <p>b) </p>	<p>K: </p> <p>N: </p>	
<p>VAS 538.080 FPM 007.030 90537241 FPM 16x</p> 	<p>493.940 12622668</p> 		<p>a) 036.164 Dirko HT / EU</p> <p>a) 510.031 Dirko HT / USA/CDN/MEX</p> <p>a) 527.291 Dirko HT / RU</p> <p>a) 648.661 Dirko HT / BR</p> <p>b) 823.400 55 577 568 +12 616 850 M 12x1,75x17</p> <p>b) 056.130 12 616 850 FPM RD 10,8x20,8x2,6</p>	<p>K:← 127.610 90571925 ASW RD FPM/ACM 42x55x7</p> <p>K:← 595.170 12584041 AW/BS OF RD FPM 42x55x7</p> <p>K:→ 441.170 12591866 ASW OF LD FPM 90x104x11</p>	
<p>VAS 424.800 FPM 403.730 90410741 FPM 16x</p>		<p>645.910 90412459</p> 	<p>a) 410.050 90467759</p> <p>↑</p>  <p>b) 115.100 94525114 CU A 14x20x1,5</p>	<p>K:← 330.736 92060272 AW/BS RD FPM 31x50x8</p> <p>K:→ 694.770 90354378 ASW LD FPM/ACM 90x104x11</p> <p>N:← 702.269 96183314 AW/BS RD VMQ 35x48x7 2x</p>	
<p>VAS 538.080 FPM 007.030 90537241 FPM 16x</p> 	<p>493.940 12622668</p>  <p>855.200 12589453</p> 		<p>a) 036.164 Dirko HT / EU</p> <p>a) 510.031 Dirko HT / USA/CDN/MEX</p> <p>a) 527.291 Dirko HT / RU</p> <p>a) 648.661 Dirko HT / BR</p> <p>b) 823.400 55 577 568 +12 616 850 M 12x1,75x17</p> <p>b) 056.130 12 616 850 FPM RD 10,8x20,8x2,6</p>	<p>K:← 127.610 90571925 ASW RD FPM/ACM 42x55x7</p> <p>K:← 595.170 12584041 AW/BS OF RD FPM 42x55x7</p> <p>K:→ 441.170 12591866 ASW OF LD FPM 90x104x11</p>	

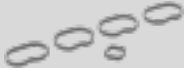
<p>CHEVROLET/ DAEWOO</p> 				
<p>LE5</p> <p>4 Cyl. 2384 ccm Cyl. 88,0 Ø</p> <p>Captiva 12/2009 →</p> <p>Cobalt 07/2004 →</p> <p>HHR 01/2006 → 12/2011</p> <p>Malibu 01/2008 →</p>	<p>ES⊕ 558.880 CS* 483.740 OKS 803.630</p>	<p>167.911 12 597 769 0,64 mm $\frac{3}{8}$ 89,4 Ø</p> 	<p>ZKS 257.910 90537691 (10x) M 11x1,5x162</p>  <p>ZKS 509.710 90 537 691 (10x) 24407225 (4x) M 11x1,5x162 / M 8</p> 	<p>ZKHS 483.780 12598014</p>  <p>AL</p>
<p>LE9(145CUL4)</p> <p>4 Cyl. 2384 ccm Cyl. 88,0 Ø</p> <p>Captiva 12/2009 →</p> <p>HHR 09/2008 → 12/2011</p> <p>Malibu 09/2009 →</p>	<p>ES⊕ 558.880 CS* 483.740</p>	<p>167.911 12 597 769 0,64 mm $\frac{3}{8}$ 89,4 Ø</p> 	<p>ZKS 257.910 90537691 (10x) M 11x1,5x162</p>  <p>ZKS 509.710 90 537 691 (10x) 24407225 (4x) M 11x1,5x162 / M 8</p> 	<p>ZKHS 483.780 12598014</p>  <p>AL</p>
<p>LAF LUK LEA</p> <p>4 Cyl. 2384 ccm Cyl. 88,0 Ø</p> <p>Captiva 09/2011 →</p> <p>Equinox 09/2009 → 12/2017</p> <p>Impala 07/2013 →</p> <p>Malibu 01/2012 →</p> <p>Orlando 09/2011 →</p>	<p>ES⊕ 935.330 CS* 483.740</p>	<p>514.960 12611196 0,64 mm $\frac{3}{8}$ 89 Ø</p> 	<p>ZKS 257.910 90537691 (10x) M 11x1,5x162</p>  <p>ZKS 509.710 90 537 691 (10x) 24407225 (4x) M 11x1,5x162 / M 8</p> 	<p>ZKHS 935.310 12609291</p>
<p>LCV</p> <p>4 Cyl. 2457 ccm Cyl. 88,0 Ø</p> <p>Blazer 06/2018 →</p> <p>Colorado 09/2014 →</p> <p>Impala 06/2015 →</p> <p>Malibu 09/2012 →</p> <p>S10 09/2014 →</p>	<p>ES⊕ 927.910 CS* 927.950</p>	<p>730.792 12648979 0,68 mm $\frac{3}{8}$ 89,3 Ø</p> 	<p>ZKS 821.950 11610687 (10x) M 11x2,0x165</p> 	<p>ZKHS 927.920 812.030 12635953 912.510 12613249 4x</p> 

			<p>a) </p> <p>b) </p>	<p>K: </p> <p>N: </p>	
<p>VAS 538.080 FPM</p> <p>007.030 90537241 FPM 16x</p> 	<p>493.940 12622668</p>  <p>855.200 12589453</p> 		<p>a) 036.164 Dirko HT / EU</p> <p>a) 510.031 Dirko HT / USA/CDN/MEX</p> <p>a) 527.291 Dirko HT / RU</p> <p>a) 648.661 Dirko HT / BR</p> <p>b) 823.400 55 577 568 +12 616 850 M 12x1,75x17</p> <p>b) 056.130 12 616 850 FPM RD 10,8x20,8x2,6</p>	<p>K:← 127.610 90571925 ASW RD FPM/ACM 42x55x7</p> <p>K:← 595.170 12584041 AW/BS OF RD FPM 42x55x7</p> <p>K:→ 441.170 12591866 ASW OF LD FPM 90x104x11</p>	
<p>VAS 538.080 FPM</p> <p>007.030 90537241 FPM 16x</p> 	<p>493.940 12622668</p> 		<p>a) 036.164 Dirko HT / EU</p> <p>a) 510.031 Dirko HT / USA/CDN/MEX</p> <p>a) 527.291 Dirko HT / RU</p> <p>a) 648.661 Dirko HT / BR</p> <p>b) 823.400 55 577 568 +12 616 850 M 12x1,75x17</p> <p>b) 056.130 12 616 850 FPM RD 10,8x20,8x2,6</p>	<p>K:← 127.610 90571925 ASW RD FPM/ACM 42x55x7</p> <p>K:← 595.170 12584041 AW/BS OF RD FPM 42x55x7</p> <p>K:→ 441.170 12591866 ASW OF LD FPM 90x104x11</p>	
<p>VAS 538.080 FPM</p> <p>007.030 90537241 FPM 16x</p> 	<p>493.940 12622668</p> 	<p>AAS 509.570</p> 	<p>a) 036.164 Dirko HT / EU</p> <p>a) 510.031 Dirko HT / USA/CDN/MEX</p> <p>a) 527.291 Dirko HT / RU</p> <p>a) 648.661 Dirko HT / BR</p> <p>b) 823.400 55 577 568 +12 616 850 M 12x1,75x17</p> <p>b) 056.130 12 616 850 FPM RD 10,8x20,8x2,6</p>	<p>K:← 127.610 90571925 ASW RD FPM/ACM 42x55x7</p> <p>K:← 595.170 12584041 AW/BS OF RD FPM 42x55x7</p> <p>K:→ 441.170 12591866 ASW OF LD FPM 90x104x11</p>	
<p>659.440 19207664 FPM 16x</p> 	<p>560.000 12627072</p>	<p>564.350 12655276</p> 	<p>a) 036.164 Dirko HT / EU</p> <p>a) 510.031 Dirko HT / USA/CDN/MEX</p> <p>a) 527.291 Dirko HT / RU</p> <p>a) 648.661 Dirko HT / BR</p> <p>b) 823.400 55 577 568 +12 616 850 M 12x1,75x17</p> <p>b) 056.130 12 616 850 FPM RD 10,8x20,8x2,6</p>	<p>K:← 562.090 12626923 AW/BS OF RD FPM 44,8x61x9</p> <p>K:→ 441.170 12591866 ASW OF LD FPM 90x104x11</p>	

**CHEVROLET/
DAEWOO**

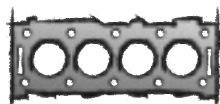
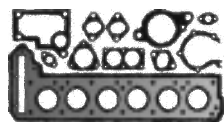

LKW
4 Cyl. **2457 ccm**
Cyl. 88,0 Ø

Impala
07/2013 →
Malibu
07/2013 →

ES⊕ **519.530**
CS* **927.950**

730.792
12648979
0,68 mm $\frac{2}{3}$ 89,3 Ø

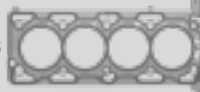



ZKS 821.950
11610687 (10x)
M 11x2,0x165



ZKHS 710.770

LKH
4 Cyl. **2499 ccm**
Cyl. 92,0 Ø

S⊕ **575.250**

ES⊕ **575.260**

CS* **585.620**

279.532
55599222
 0,300 mm
→
0,399 mm
1,10 mm $\frac{2}{3}$ 95 Ø



279.542
55599223
 0,400 mm
→
0,499 mm
1,20 mm $\frac{2}{3}$ 95 Ø
1 ⊗



279.422
55599224
 0,500 mm
→
0,599 mm
1,30 mm $\frac{2}{3}$ 95 Ø
2 ⊗



ZKS 906.110
55595130 (10x)
M 14x1,5x155



ZKHS 767.110

LVN
4 Cyl. **2499 ccm**
Cyl. 92,0 Ø

Trailblazer
08/2012 →

S⊕* **617.820**

ES⊕ **618.280**

CS* **619.090**

279.532
55599222
 0,300 mm
→
0,399 mm
1,10 mm $\frac{2}{3}$ 95 Ø



279.542
55599223
 0,400 mm
→
0,499 mm
1,20 mm $\frac{2}{3}$ 95 Ø
1 ⊗

















279.422
55599224
 0,500 mm
→
0,599 mm
1,30 mm $\frac{2}{3}$ 95 Ø
2 ⊗



ZKS 906.110
55595130 (10x)
M 14x1,5x155



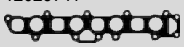





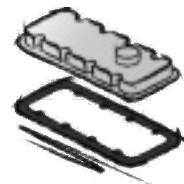
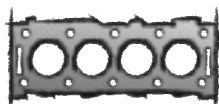
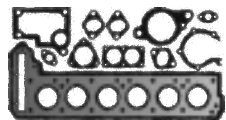









ZKHS 767.110

			<p>a) </p> <p>b) </p>	<p>K: </p> <p>N: </p>	
<p>659.440 19207664 FPM 16x</p> 	<p>560.000 12627072</p>		<p>a) 036.164 Dirko HT / EU</p> <p>a) 510.031 Dirko HT / USA/CDN/MEX</p> <p>a) 527.291 Dirko HT / RU</p> <p>a) 648.661 Dirko HT / BR</p> <p>b) 823.400 55 577 568 +12 616 850 M 12x1,75x17</p> <p>b) 056.130 12 616 850 FPM RD 10,8x20,8x2,6</p>	<p>K:← 562.090 12626923 AW/BS OF RD FPM 44,8x61x9</p> <p>K:→ 441.170 12591866 ASW OF LD FPM 90x104x11</p>	
<p>VAS 424.800 FPM</p> <p>403.730 90410741 FPM 16x</p>	<p>121.590 12642186</p>	<p>575.430 12637739</p> 	<p>a) 364.900 12625698</p>  <p>a) 364.950 12629737 Colorado 12A</p>  <p>b) 823.400 55 577 568 +12 616 850 M 12x1,75x17</p>	<p>K:← 072.850 12625418 AW RD PTFE/ACM 56x70,3x8,3</p> <p>K:← 298.770 AW RD PTFE/ACM 56x70,25x8,2</p> <p>K:← 591.410 12642203 ASW RD PTFE/ACM 56x70,3x8</p> <p>K:→ 298.670 12625417 SP LD PTFE/ACM 100</p> <p>N:← 302.170 12625418 AW RD PTFE/ACM 38x55x6,2</p>	<p>TLS 302.530</p> 
<p>VAS 424.800 FPM</p> <p>403.730 90410741 FPM 16x</p>	<p>121.590 12642186</p>	<p>121.740 12625711</p> <p>305.410 ● 12625711</p> 	<p>a) 364.900 12625698</p>  <p>a) 364.950 12629737</p> 	<p>K:← 072.850 12625418 AW RD PTFE/ACM 56x70,3x8,3</p> <p>K:← 298.770 AW RD PTFE/ACM 56x70,25x8,2</p> <p>K:→ 298.670 12625417 SP LD PTFE/ACM 100</p> <p>N:← 302.170 12625418 AW RD PTFE/ACM 38x55x6,2</p>	









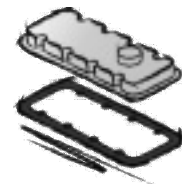
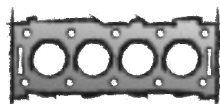
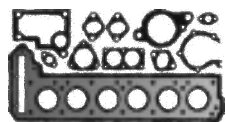







**CHEVROLET/
DAEWOO**

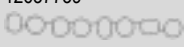









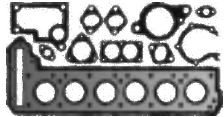
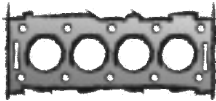

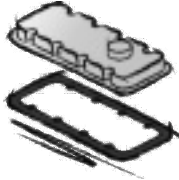
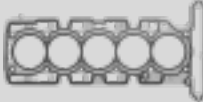
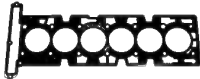



			<p>a) </p> <p>b) </p>	<p>K: </p> <p>N: </p>	
<p>VAS 424.800 FPM 403.730 90410741 FPM 16x</p>	<p>121.590 12642186</p>	<p>121.740 12625711 →08/2013 305.410 ● 12625711 →08/2013  575.430 12637739 08/2013→ </p>	<p>a) 364.900 12625698  a) 364.950 12629737 </p>	<p>K:← 072.850 12625418 AW RD PTFE/ACM 56x70,3x8,3 K:← 298.770 AW RD PTFE/ACM 56x70,25x8,2 K:→ 298.670 12625417 SP LD PTFE/ACM 100 N:← 302.170 12625418 AW RD PTFE/ACM 38x55x6,2</p>	
		<p>AAS 480.410</p>	<p>b) 823.400 55 577 568 +12 616 850 M 12x1,75x17 b) 056.130 12 616 850 FPM RD 10,8x20,8x2,6</p>	<p>K:← 845.550 89017622 AW/BS RD PTFE/FPM 46x59,5x10,4</p>	
<p>VAS 424.800 FPM 403.730 90410741 FPM 16x</p>	<p>121.590 12642186</p>	<p>121.740 12625711 305.410 ● 12625711 </p>	<p>a) 364.900 12625698  a) 364.950 12629737 </p>	<p>K:← 072.850 12625418 AW RD PTFE/ACM 56x70,3x8,3 K:→ 298.670 12625417 SP LD PTFE/ACM 100 N:← 302.170 12625418 AW RD PTFE/ACM 38x55x6,2</p>	<p>TLS 302.530 </p>

**CHEVROLET/
DAEWOO**



			<p>a) </p> <p>b) </p>	<p>K: </p> <p>N: </p>	
<p>VAS 424.800 FPM 403.730 90410741 FPM 16x</p>	<p>121.590 12642186</p>	<p>575.430 12637739</p> 	<p>a) 364.900 12625698</p>  <p>a) 364.950 12629737 Colorado 12A</p>  <p>b) 823.400 55 577 568 +12 616 850 M 12x1,75x17</p>	<p>K:← 072.850 12625418 AW RD PTFE/ACM 56x70,3x8,3</p> <p>K:← 298.770 AW RD PTFE/ACM 56x70,25x8,2</p> <p>K:← 591.410 12642203 ASW RD PTFE/ACM 56x70,3x8</p> <p>K:→ 298.670 12625417 SP LD PTFE/ACM 100</p> <p>N:← 302.170 12625418 AW RD PTFE/ACM 38x55x6,2</p>	<p>TLS 302.530</p> 
<p>472.240 FPM 12x</p>	<p>381.130 4x</p> 	<p>582.850</p> 	<p>a) 582.840</p>  <p>b) 813.133 CU C 22x29x2</p>		
<p>853.310 12596995 FPM 16x</p> 		<p>AAS 480.410</p>	<p>b) 823.400 55 577 568 +12 616 850 M 12x1,75x17</p> <p>b) 056.130 12 616 850 FPM RD 10,8x20,8x2,6</p>	<p>K:← 845.550 89017622 AW/BS RD PTFE/FPM 46x59,5x10,4</p>	
<p>853.310 12596995 FPM 20x</p> 			<p>b) 823.400 55 577 568 +12 616 850 M 12x1,75x17</p> <p>b) 056.130 12 616 850 FPM RD 10,8x20,8x2,6</p>	<p>K:← 845.550 89017622 AW/BS RD PTFE/FPM 46x59,5x10,4</p>	

<p>CHEVROLET/ DAEWOO</p> 				
<p>LLR</p> <p>5 Cyl. 3653 ccm Cyl. 95,5 Ø</p> <p>Colorado 09/2006 → 12/2012</p>		<p>197.690 12 580 905 0,65 mm $\frac{+}{-}$ 96,4 Ø</p> 		
<p>LL8(254CUL6)</p> <p>6 Cyl. 4157 ccm Cyl. 93,0 Ø</p> <p>Trailblazer 09/2001 → 12/2009</p>	<p>ES⊕ 518.250 89060567 CS* 928.420</p>	<p>494.110 12609730 0,65 mm $\frac{+}{-}$ 93,7 Ø 2x</p> 		<p>ZKHS 518.260 89017827</p>

			<p>a) </p> <p>b) </p>	<p>K: </p> <p>N: </p>	
<p>853.310 12596995 FPM 20x</p> 			<p>b) 823.400 55 577 568 +12 616 850 M 12x1,75x17</p> <p>b) 056.130 12 616 850 FPM RD 10,8x20,8x2,6</p>	<p>K:← 845.550 89017622 AW/BS RD PTFE/FPM 46x59,5x10,4</p>	
<p>853.310 12596995 FPM 24x</p> 	<p>167.881 12595010</p>	<p>AAS 823.470 89017871</p> 	<p>b) 823.400 55 577 568 +12 616 850 M 12x1,75x17</p> <p>b) 056.130 12 616 850 FPM RD 10,8x20,8x2,6</p>	<p>K:← 845.550 89017622 AW/BS RD PTFE/FPM 46x59,5x10,4</p> <p>K:→ 846.160 12581717 AW/BS LD PTFE/ACM 100,8x128,2x13,6</p>	

CHRYSLER/DODGE/JEEP



CHRYSLER/DODGE/JEEP

CHRYSLER/ DODGE/JEEP	ccm	kW	→	→		
200	4	2360	129	01/2011		EDG 652 654
200	6	3604	211	09/2010		ERB 664
200	6	3604	208	02/2014	08/2014	ERB 664
200	6	3604	217	06/2014	12/2014	ERB 664
200	6	3604	220	06/2014		ERB 664
300 C	6	2736	130	01/2007	11/2012	EES 658
300 C	6	3604	218	09/2010		ERB 664
300 C	6	3604	215	07/2011		ERB 664
300 C	6	3604	210	09/2011		ERB 664
300 C	6	3604	224	09/2014		ERB 664
300 C	6	3604	216	04/2015		ERB 664
300 C	6	3604	213	01/2017		ERB 664
300 C	8	5654	250	09/2004	12/2010	EZD 664
300 C	8	5654	268	09/2008		EZD 664
300 C CRD	6	2987	160	09/2005	11/2012	EXL 662
300 C CRD	6	2987	155	11/2010	11/2012	EXL 662
Aspen	8	5654	280	04/2008	12/2008	EZD 664
Aspen	8	5654	250	09/2008		EZD 664
Aspen	8	5654	287	09/2008	12/2009	EZD 664
Aspen	8	5654	246	12/2008		EZD 664
Avenger	4	1998	115	06/2007	12/2011	ECN 650
Avenger	6	2736	137	06/2007	12/2011	EER 658
Avenger	6	2736	139	06/2007	12/2009	EER 658
Avenger	6	2736	141	06/2007	12/2010	EER 658
Avenger	6	2736	142	09/2007	12/2009	EER 658
Caliber	4	1798	110	06/2006	12/2009	EBA 642
Caliber	4	1998	115	06/2006		ECN 650
Caliber	4	1998	118	09/2008	12/2012	ECN 650
Caliber	4	2359	217	12/2007		ED4 652
Caliber	4	2360	223	10/2006		ED4 652
Caliber	4	2360	213	09/2007	12/2009	ED4 652
Caravan	6	2972	100	10/1988	09/1990	EFA 660
Caravan	6	2972	105	09/1990	12/1995	EFA 660
Caravan	6	2972	106	09/1990	12/1995	EFA 660
Caravan	6	2972	112	01/1995	06/2000	EFA 660
Caravan TD	4	2499	85	01/1995	03/2001	ENC 656

CHRYSLER/ DODGE/JEEP	ccm	kW	→	→		
Charger	6	2736	141	04/2006	12/2010	EER 658
Charger	6	2736	133	09/2008	12/2010	EER 658
Charger	8	5654	261	09/2008	12/2010	EZD 666
Charger	8	5654	276	09/2008	12/2010	EZD 666
Cherokee CRD	4	1956	103	04/2014	08/2018	EBS 646 EBT
Cherokee CRD	4	1956	125	04/2014	08/2018	EBS 646 EBT
Cherokee CRD	4	2499	105	09/2001	01/2008	R 425 DOHC 654
Cherokee CRD	4	2777	130	05/2008		ENS 660
Cherokee CRD	4	2777	147	01/2010		ENS 660
Cherokee TD	4	2068	64	10/1984	09/2001	J8S 650
Cherokee TD	4	2068	59	10/1986	09/1992	J8S 650 J8S 742
Cirrus	6	2736	149	09/2000	12/2006	EES 658
CJ5 - CJ8	4	1995	63	01/1983	12/1987	J5R-800 650
CJ5 - CJ8 Diesel	4	2068	44	01/1983	12/1987	J8S-800 650
Comanche TD	4	2068	63	01/1986	09/1990	J8S-814 650
Commander CRD	4	1956	125	10/2021		552 63 088 644
Compass	4	1368	103	03/2017		552 63 624 638 EAQ
Compass	4	1368	120	03/2017		EAM 638 EAQ
Compass	4	1368	125	03/2017		552 63 623 638 EAQ
Compass	4	2359	125	08/2006		ED3 652 654
Compass	4	2360	128	08/2006		ED3 652
Compass CRD	4	1598	88	03/2017		552 60 384 640 EJJ
Compass CRD	4	1956	125	12/2016		552 63 088 644 EBS 646
Compass CRD	4	1956	103	03/2017		552 63 087 644 EBS 646 EBT
Compass CRD	4	1968	103	08/2006		ECE 648
Compass CRD	4	2143	100	05/2011		ENE 652
Compass Multijet	4	1956	127	03/2017		552 63 088 644 EBS 646 EBT
Crossfire	6	3199	160	07/2003	12/2008	EGX 662
Crossfire	6	3199	246	09/2004	12/2007	EGZ 662
Dakota	4	2499	85	10/1998	12/2001	HR425 656



CHRYSLER/ DODGE/JEEP	ccm	kW	→	→		
Dart	4	1368	119	04/2012		EAF 638
Daytona	6	2972	105	09/1989	12/1993	EFA 660
Delta	4	1368	88	08/2011		198 A4.000 636
Delta	4	1368	103	08/2011		198 A7.000 636
Delta Multijet	4	1598	88	08/2011		198 A2.000 638
Delta Multijet	4	1956	121	08/2011		198 A5.000 644
Durango	8	5654	250	09/2003	12/2009	EZD 666
Dynasty	6	2972	104	09/1988	12/1993	6G72 (SOHC 12V) 660
Grand Caravan	6	2972	106	09/1986	12/1995	EFA 660
Grand Caravan	6	2972	112	09/1995	12/2000	EFA 660
Grand Cherokee	8	5654	259	01/2009	12/2010	EZD 666
Grand Cherokee	8	5654	265	01/2009	12/2010	EZD 666
Grand Cherokee CRD	5	2685	120	10/2001	09/2005	OM 665.921 658
Grand Cherokee TD	5	3125	103	04/1999	12/2001	EXA 662
Grand Voyager	6	3604	208	02/2011		ERB 664
Grand Voyager	6	3604	211	02/2011		ERB 664
Grand Voyager CRD	4	2499	105	01/2001	02/2008	ENJ 654
Grand Voyager CRD	4	2777	110	04/2004	02/2008	ENR 658
Intrepid	6	2736	149	10/1997	09/2004	EER 658
Journey	6	2736	143	11/2008		EER 658
Journey	6	2736	136	01/2009		EER 658
Journey CRD	4	1956	125	01/2012		EBT 648
Le Baron	6	2972	105	01/1990	12/1996	6G72 660
Magnum	6	2736	142	09/2005	12/2008	EER 658
Mini Ram	6	2972	100	09/1986	12/1988	EFA 660
Neon	4	1368	71	08/2016		EAV 638
Neon	4	1598	85	11/2001	12/2006	EJD 640
Neon	4	1598	82	08/2016		EJM 642
Pacifica	6	3604	214	02/2016		ERB 664
Patriot	4	2359	125	01/2008	12/2017	ED3 652 654
Patriot	4	2360	128	02/2007	12/2017	ED3 652
Patriot CRD	4	1968	103	02/2007	12/2017	ECE 648
Patriot CRD	4	2143	100	01/2011	12/2017	ENE 652
Patriot CRD	4	2143	120	01/2011	12/2017	ENE 652
PT Cruiser	4	1598	85	11/2001	12/2010	EJD 640
PT Cruiser	4	2148	89	10/2002	08/2008	EDJ 652

CHRYSLER/ DODGE/JEEP	ccm	kW	→	→		
PT Cruiser CRD	4	2148	89	03/2002	12/2010	EDJ 652
PT Cruiser CRD	4	2148	110	08/2005	12/2010	EDJ 652
Raider	6	2972	107	09/1988	12/1989	EFA 660
RAM 1500	8	5654	291	09/2008	12/2010	EZD 666
RAM 50	6	2972	105	09/1989	12/1991	6G72 (SOHC 12V) 660
RAM 50	6	2972	106	09/1989	12/1991	6G72 (SOHC 12V) 660
RAM CRD	4	2499	105	01/2006	04/2008	ENJ 654
RAM CRD	4	2777	110	11/2005	07/2009	ENR 658
RAM TD	4	2499	85	06/1995	10/2002	ENC 656
Renegade	4	1368	103	07/2014		552 63 624 EAM 638
Renegade	4	1368	119	07/2014		EAM 638
Renegade	4	1368	125	07/2014		552 63 623 EAM 638
Renegade	4	1368	100	01/2016		552 63 624 638
Renegade	4	1598	81	07/2014		552 63 842 EJJ 640
Renegade	4	1747	97	04/2015		EBF 642
Renegade	4	1747	102	01/2016		EBF 642
Renegade	4	1747	88	02/2016		EBF 642
Renegade CRD	4	1598	88	07/2014		552 63 113 638 552 80 444 640 EJK 642
Renegade CRD	4	1598	70	11/2016		552 60 384 EJJ 640
Renegade CRD	4	1956	88	07/2014		552 63 087 EBT 644 646
Renegade CRD	4	1956	103	07/2014		552 63 087 644 552 63 088 646 552 83 099 552 84 064 EBT
Renegade CRD	4	1956	125	07/2014		552 63 088 644 552 83 099 646 EBT
Renegade CRD	4	1956	126	04/2015		552 63 088 644 EBT 646
Saratoga	6	2972	105	09/1989	12/1995	6G72 660
Sebring	4	2360	128	09/2006	12/2010	EDG 654
Sebring	4	2360	125	07/2007	12/2010	EDG 652 654
Sebring	6	2736	149	04/2001	06/2007	EES 658
Sebring CRD	4	1968	103	07/2007	12/2010	ECD 648

CHRYSLER/DODGE/JEEP



CHRYSLER/
DODGE/JEEP

ccm kW

→ →

Shadow	6	2972	105	09/1991	12/1994	EFA	660
Spirit	6	2972	105	09/1988	12/1995	EFA	660
Sprinter 2500	5	2685	115	09/2003	12/2006	EX8	656
Sprinter 2500	6	2987	115	09/2006	12/2009	EXM	662
Sprinter 2500	6	3498	189	09/2006	12/2007	EG2	664
Sprinter 2500	6	3498	190	09/2006	12/2008	EG2	664
Sprinter 3500	5	2685	115	09/2002	12/2006	EX8	656
Sprinter 3500	6	2987	115	09/2006	12/2009	EXM	662
Sprinter 3500	6	3498	189	09/2006	12/2008	EG2	664
Stealth	6	2972	122	09/1990	12/1996	6G72 (SOHC 12V)	660
Stratus	6	2736	149	09/2000	10/2006	EER	658
Stratus	6	2736	148	10/2000	10/2006	EER	658
Voyager	6	2972	108	01/1991	09/1995	300 6G72	660
Voyager CRD	4	2499	105	02/2000	12/2008	ENJ	654
Voyager CRD	4	2499	88	08/2005	12/2008	EDK	654
Voyager CRD	4	2776	110	06/2004	12/2008	ENR	658
Voyager TD	4	2499	85	01/1992	03/2001	425 CLIRS/X VM HR 425 CLIEE	656
Voyager TD	4	2499	87	01/1992	09/1995	09B	656
Voyager TD	4	2500	87	01/1992	09/1995	09B M00	656
Wagoneer	8	5654	268	01/2022		EZL	666
Wrangler CRD	4	2776	147	11/2010		ENS	660
Wrangler CRD	4	2777	130	04/2007		ENS	660
Wrangler CRD	4	2777	120	07/2010		ENS	660
Ypsilon	2	875	63	05/2011		312 A2.000	636
Ypsilon	4	1242	51	05/2011		169 A4.000	636
Ypsilon Multijet	4	1248	70	05/2011		199 B1.000	636

CHRYSLER/DODGE/JEEP

CHRYSLER/DODGE/JEEP



CHRYSLER/DODGE/JEEP

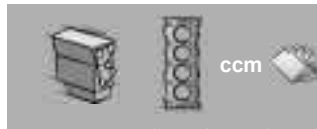

09B	4	2500	656
169 A4.000	4	1242	636
198 A2.000	4	1598	638
198 A4.000	4	1368	636
198 A5.000	4	1956	644
198 A7.000	4	1368	636
199 B1.000	4	1248	636
300	6	2972	660
312 A2.000	2	875	636
425 CLIRS/X	4	2499	656
552 60 384	4	1598	640
552 63 087	4	1956	644
552 63 088	4	1956	644
552 63 113	4	1598	638
552 63 623	4	1368	638
552 63 624	4	1368	638
552 63 842	4	1598	640
552 80 444	4	1598	640
552 83 099	4	1956	646
552 84 064	4	1956	646
6G72	6	2972	660
6G72 (SOHC 12V)	6	2972	660
EAF	4	1368	638
EAM	4	1368	638
EAQ	4	1368	638
EAV	4	1368	638
EBA	4	1798	642
EBF	4	1747	642
EBS	4	1956	646
EBT	4	1956	648
EBT	4	1956	646
ECD	4	1968	648
ECE	4	1968	648
ECN	4	1998	650
ED3	4	2360	652
ED4	4	2360	652











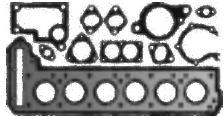
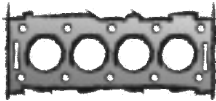

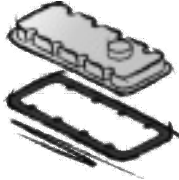



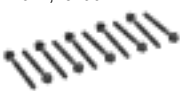
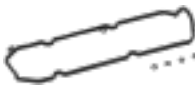

EDG	4	2360	654
EDJ	4	2148	652
EDK	4	2499	654
EER	6	2736	658
EES	6	2736	658
EFA	6	2972	660
EG2	6	3498	664
EGX	6	3199	662
EGZ	6	3199	662
EJD	4	1598	640
EJH	4	1598	640
EJJ	4	1598	640
EJK	4	1598	642
EJM	4	1598	642
ENC	4	2499	656
ENE	4	2143	652
ENJ	4	2499	654
ENR	4	2777	658
ENS	4	2777	660
ERB	6	3604	664
EX8	5	2685	656
EXA	5	3125	662
EXL	6	2987	662
EXM	6	2987	662
EZD	8	5654	666
EZD	8	5654	666
EZD	8	5654	664
EZL	8	5654	666
HR425	4	2499	656
HR 425 CLI	4	2499	656
J5R-800	4	1995	650
J8S	4	2068	650
J8S	4	2068	650
J8S 742	4	2068	650
J8S-800	4	2068	650
J8S-814	4	2068	650
J8S 890	4	2068	650

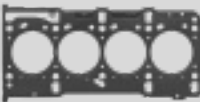



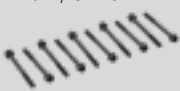
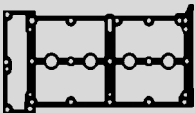

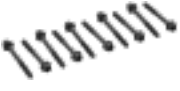

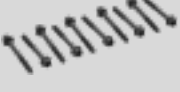
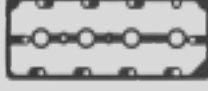







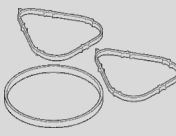

J8S-890	4	2068	650
M00	4	2500	656
M51	4	2499	656
M52	4	2499	656
OM 665.921	5	2685	658
R 425 DOHC	4	2499	654
VM HR 425 CLIEE	4	2499	656











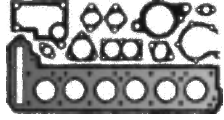
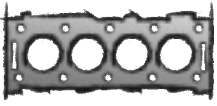



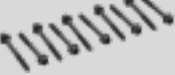
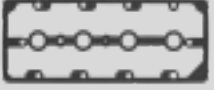

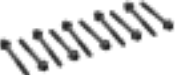

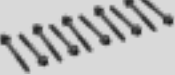
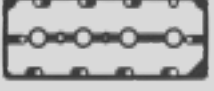

CHRYSLER/DODGE/JEEP



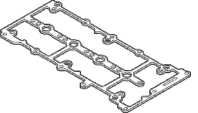





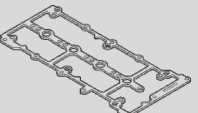







CHRYSLER/DODGE/JEEP









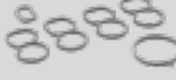

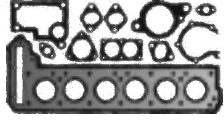
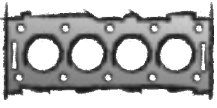

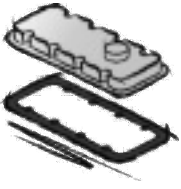



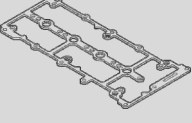



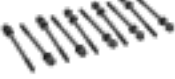







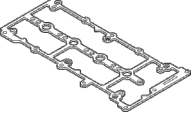









<p>CHRYSLER/ DODGE/JEEP</p> 				
<p>312 A2.000</p> <p>2 Cyl. 875 ccm Cyl. 80,5 Ø</p> <p>Ypsilon 05/2011 →</p>	<p>ES⊕ 047.221 Euro 5 CS* 299.401 OKS 888.410</p>	<p>655.980 0,72 mm $\frac{2}{3}$ 82,7 Ø</p> 	<p>ZKS 949.350 M 9x1,25x120</p>	<p>ZKHS 005.660</p> 
<p>169 A4.000</p> <p>4 Cyl. 1242 ccm Cyl. 70,8 Ø</p> <p>Ypsilon 05/2011 →</p>	<p>ES⊕ 037.461 CS* 431.560</p>	<p>040.554 0,49 mm $\frac{2}{3}$ 72,4 Ø</p> 	<p>ZKS 760.720 M 9x1,25x96</p> 	<p>ZKHS 724.280</p>  <p>505.060</p> 
<p>199 B1.000</p> <p>4 Cyl. 1248 ccm Cyl. 69,6 Ø</p> <p>Ypsilon Multijet 05/2011 →</p>	<p>ES⊕ 789.900  CS* 397.470</p>	<p>076.348  0,028 mm → 0,127 mm 0,72 mm $\frac{2}{3}$ 70,6 Ø</p>  <p>076.358  0,128 mm → 0,227 mm 0,82 mm $\frac{2}{3}$ 70,6 Ø 1 ⊗</p>  <p>076.408  0,228 mm → 0,327 mm 0,92 mm $\frac{2}{3}$ 70,6 Ø 2 ⊗</p> 	<p>ZKS 374.240 M 10x1,25x119</p> 	<p>074.173</p> 
<p>198 A4.000</p> <p>4 Cyl. 1368 ccm Cyl. 72,0 Ø</p> <p>Delta 08/2011 →</p>	<p>ES⊕ 928.770 CS 928.760</p>	<p>344.671 04893239AA 0,72 mm $\frac{2}{3}$ 72,4 Ø</p> 	<p>ZKS 111.590 M 9x1,25x87</p> 	<p>199.010</p> 
<p>198 A7.000</p> <p>4 Cyl. 1368 ccm Cyl. 72,0 Ø</p> <p>Delta 08/2011 →</p>	<p>CS 928.790</p>	<p>344.671 04893239AA 0,72 mm $\frac{2}{3}$ 72,4 Ø</p> 	<p>ZKS 111.590 M 9x1,25x87</p> 	<p>199.010</p> 







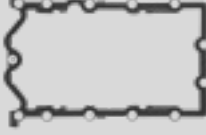



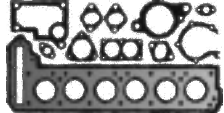
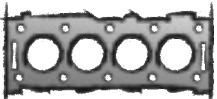

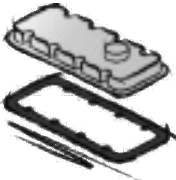
			<p>a) </p> <p>b) </p>	<p>K: </p> <p>N: </p>	
VAS 710.840 FPM	574.630 	AAS 008.170 	<p>a) 030.793 Dirko HT</p> <p>b) 878.110 M 12x1,25x13</p> <p>b) 110.604 CU A 12x16x1,5</p>	<p>K:← 069.590 68096793AA AW/BS RD FPM 31x41x7</p> <p>K:→ 135.110 ASW LD FPM/ACM 85x105x9</p>	TLS 002.360
VAS 688.050 FPM 476.691 FPM 8x	375.070 	AAS 444.760 	<p>a) 030.793 Dirko HT</p> <p>b) 587.100 M 22x1,5x13</p>	<p>K:← 069.540 AW/BS RD FPM 27x37x7</p> <p>K:→ 069.600 AW/BS LD FPM 74x88x8</p> <p>N:← 290.710 AW/BS RD FPM 40x55x7</p>	
VAS 445.100 FPM	431.310 	718.200 4x 	<p>a) 030.793 Dirko HT</p> <p>b) 274.410 M 14x1,5x13,5</p>	<p>K:← 445.060 AW/BS RD FPM 40x52x7</p> <p>K:→ 428.970 ASW LD PTFE/ACM 78x100x9</p>	TLS 007.810 
069.630 04892674AB FPM 16x	514.161 	AAS 334.670 	<p>a) 030.793 Dirko HT</p> <p>b) 878.110 M 12x1,25x13</p> <p>b) 110.604 CU A 12x16x1,5</p>	<p>K:← 069.540 AW/BS RD FPM 27x37x7</p> <p>K:→ 375.320 04892647AC SP LD FPM 74</p> <p>N:← 290.710 AW/BS RD FPM 40x55x7</p>	TLS 796.230 
069.630 04892674AB FPM 16x	718.411 	AAS 334.670 	<p>a) 030.793 Dirko HT</p> <p>b) 878.110 M 12x1,25x13</p> <p>b) 110.604 CU A 12x16x1,5</p>	<p>K:← 069.540 AW/BS RD FPM 27x37x7</p> <p>K:→ 375.320 04892647AC SP LD FPM 74</p> <p>N:← 290.710 AW/BS RD FPM 40x55x7</p>	TLS 002.490





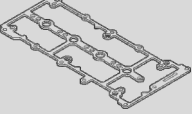













<p>CHRYSLER/ DODGE/JEEP</p> 				
<p>552 63 623/624 EAM EAQ</p> <p>4 Cyl. 1368 ccm Cyl. 72,0 Ø</p> <p>Compass 03/2017 →</p> <p>Renegade 07/2014 →</p>	<p>CS 928.790</p>	<p>344.671 04893239AA 0,72 mm $\frac{\pm}{\pm}$ 72,4 Ø</p> 	<p>ZKS 111.590 M 9x1,25x87</p> 	<p>ZKHS 944.170 199.010</p>  <p>944.000</p>  <p>939.400 68120414AA 4x</p>
<p>EAF</p> <p>4 Cyl. 1368 ccm Cyl. 72,0 Ø</p> <p>Dart 04/2012 →</p>	<p>ES⊕ 928.770 CS 928.760</p>	<p>344.671 04893239AA 0,72 mm $\frac{\pm}{\pm}$ 72,4 Ø</p> 	<p>ZKS 111.590 M 9x1,25x87</p> 	<p>199.010</p> 
<p>EAV</p> <p>4 Cyl. 1368 ccm Cyl. 72,0 Ø</p> <p>Neon 08/2016 →</p>	<p>ES⊕ 431.590 CS* 309.990</p>	<p>344.661 0,49 mm $\frac{\pm}{\pm}$ 72,4 Ø 05/2006 →</p> 	<p>ZKS 111.590 M 9x1,25x87</p> 	<p>199.010</p> 
<p>198 A2.000</p> <p>4 Cyl. 1598 ccm Cyl. 79,5 Ø</p> <p>Delta Multijet 08/2011 →</p>	<p>ES⊕ 399.870 Mot. 6491051 →</p>  <p>CS* 592.910</p>	<p>789.180 0,82 mm $\frac{\pm}{\pm}$ 80,5 Ø</p>  <p>789.190 0,92 mm $\frac{\pm}{\pm}$ 80,5 Ø 1 ⊗</p>  <p>789.200 1,02 mm $\frac{\pm}{\pm}$ 80,5 Ø 2 ⊗</p> 	<p>ZKS 524.160 M 12x1,25x98</p> 	<p>748.591 68219780AA</p> 
<p>552 63 113</p> <p>4 Cyl. 1598 ccm Cyl. 79,5 Ø</p> <p>Renegade CRD 07/2014 →</p>	<p>ES⊕ 644.760</p>  <p>ES⊕ 926.670</p>  <p>CS* 926.680</p>	<p>789.180 0,82 mm $\frac{\pm}{\pm}$ 80,5 Ø</p>  <p>789.190 0,92 mm $\frac{\pm}{\pm}$ 80,5 Ø 1 ⊗</p>  <p>789.200 1,02 mm $\frac{\pm}{\pm}$ 80,5 Ø 2 ⊗</p> 	<p>ZKS 524.160 M 12x1,25x98</p> 	<p>748.591 68219780AA</p> 







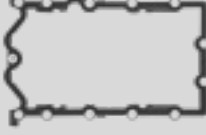



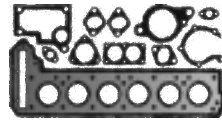
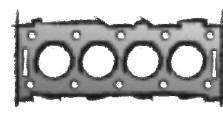

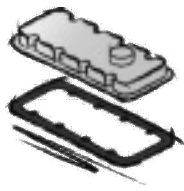







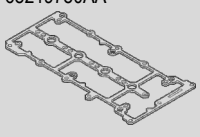

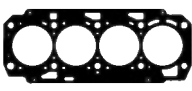

			<p>a) </p> <p>b) </p>	<p>K: </p> <p>N: </p>	
<p>069.630 04892674AB FPM 16x</p>	<p>718.411 </p>	<p>AAS 926.370</p>	<p>a) 030.793 Dirko HT</p> <p>b) 878.110 M 12x1,25x13</p> <p>b) 110.604 CU A 12x16x1,5</p>	<p>K:← 069.540 AW/BS RD FPM 27x37x7</p> <p>K:→ 375.320 04892647AC SP LD FPM 74</p> <p>N:← 688.580 AW/BS RD FPM 31x55x7</p>	<p>TLS 940.450</p>
<p>069.630 04892674AB FPM 16x</p>	<p>514.161 </p>	<p>AAS 334.670 </p>	<p>a) 030.793 Dirko HT</p> <p>b) 878.110 M 12x1,25x13</p> <p>b) 110.604 CU A 12x16x1,5</p>	<p>K:← 069.540 AW/BS RD FPM 27x37x7</p> <p>K:→ 375.320 04892647AC SP LD FPM 74</p> <p>N:← 290.710 AW/BS RD FPM 40x55x7</p>	
<p>069.630 04892674AB FPM 16x</p>	<p>339.260 </p>	<p>AAS 689.940 </p>	<p>a) 030.793 Dirko HT</p> <p>b) 587.100 M 22x1,5x13</p> <p>b) 878.110 M 12x1,25x13</p> <p>b) 110.604 CU A 12x16x1,5</p>	<p>K:← 069.540 AW/BS RD FPM 27x37x7</p> <p>K:→ 375.320 04892647AC SP LD FPM 74</p> <p>N:← 290.710 AW/BS RD FPM 40x55x7</p>	
<p>506.550 68093294AA FPM 16x</p>	<p>748.510 </p>	<p>AAS 340.470 68093452AA </p>	<p>a) 030.793 Dirko HT</p> <p>b) 877.920 incl. 339.580 M 18x1,5x22</p> <p>b) 878.030 incl. 359.300 M 18x1,5x20</p> <p>b) 339.580 68098272AA CU A 18x26x1,5</p> <p>b) 359.300 FPM A 18x26x1,5 FE/FPM</p>	<p>K:← 069.590 68096793AA AW/BS RD FPM 31x41x7</p> <p>K:→ 199.191 68366078AA SP LD FPM 93x12</p> <p>N:← 434.500 68093258AA A/BS RD FPM 30x45x7</p>	
<p>506.550 68093294AA FPM 16x</p>	<p>907.400 68275163AA Euro 6 </p>	<p>AAS 340.470 68093452AA </p>	<p>a) 030.793 Dirko HT</p> <p>b) 877.920 incl. 339.580 M 18x1,5x22</p> <p>b) 878.030 incl. 359.300 M 18x1,5x20</p> <p>b) 339.580 68098272AA CU A 18x26x1,5</p> <p>b) 359.300 FPM A 18x26x1,5 FE/FPM</p>	<p>K:→ 199.191 68366078AA SP LD FPM 93x12</p> <p>N:← 434.500 68093258AA A/BS RD FPM 30x45x7</p>	<p>TLS 647.070 TLS 651.340</p>

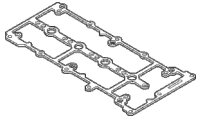







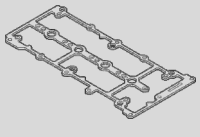







<p>CHRYSLER/ DODGE/JEEP</p> 				
<p>552 60 384 552 80 444</p> <p>4 Cyl. 1598 ccm Cyl. 79,5 Ø</p> <p>Compass CRD 03/2017 →</p> <p>Renegade CRD 07/2014 →</p>		<p>789.180 0,82 mm $\frac{2}{3}$ 80,5 Ø </p> <p>789.190 0,92 mm $\frac{2}{3}$ 80,5 Ø  1 ⊗</p> <p>789.200 1,02 mm $\frac{2}{3}$ 80,5 Ø  2 ⊗</p>	<p>ZKS 524.160 M 12x1,25x98</p> 	<p>748.591 68219780AA</p> 
<p>EJD</p> <p>4 Cyl. 1598 ccm Cyl. 77,0 Ø</p> <p>Neon 11/2001 → 12/2006</p> <p>PT Cruiser 11/2001 → 12/2010</p>	<p>ES⊕ 486.070 </p> <p>ES⊕ 574.310 CS* 903.580 →07/2004</p> <p>CS* 903.590 07/2004→</p>	<p>486.060 04693083AA 0,65 mm $\frac{2}{3}$ </p> <p>512.220 0,95 mm $\frac{2}{3}$ </p>	<p>ZKS 374.230 06505239AA (10x) M 10x1,5x149</p> 	<p>ZKHS 498.990</p>  <p>485.910 04777799AA</p> 
<p>552 63 842 EJH</p> <p>4 Cyl. 1598 ccm Cyl. 77,0 Ø</p> <p>Renegade 07/2014 →</p>	<p>ES⊕ 706.440 CS* 903.590</p>	<p>939.490 0,65 mm $\frac{2}{3}$ 78 Ø </p>	<p>ZKS 949.360 M 10x1,5x148</p>	<p>ZKHS 763.880 518.030</p> 
<p>EJJ</p> <p>4 Cyl. 1598 ccm Cyl. 79,5 Ø</p> <p>Compass CRD 03/2017 →</p> <p>Renegade CRD 11/2016 →</p>		<p>789.180 0,82 mm $\frac{2}{3}$ 80,5 Ø </p> <p>789.190 0,92 mm $\frac{2}{3}$ 80,5 Ø  1 ⊗</p> <p>789.200 1,02 mm $\frac{2}{3}$ 80,5 Ø  2 ⊗</p>	<p>ZKS 524.160 M 12x1,25x98</p> 	<p>748.591 68219780AA</p> 











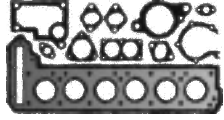
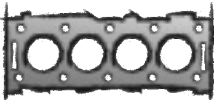

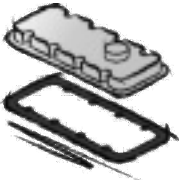

			<p>a) </p> <p>b) </p>	<p>K: </p> <p>N: </p>	
<p>506.550 68093294AA FPM 16x</p>	<p>907.400 68275163AA Euro 6</p> 	<p>AAS 340.470 68093452AA</p> 	<p>a) 030.793 Dirko HT</p> <p>b) 877.920 incl. 339.580 M 18x1,5x22</p> <p>b) 878.030 incl. 359.300 M 18x1,5x20</p> <p>b) 339.580 68098272AA CU A 18x26x1,5</p> <p>b) 359.300 FPM A 18x26x1,5 FE/FPM</p>	<p>K:← 069.590 68096793AA AW/BS RD FPM 31x41x7</p> <p>K:→ 199.191 68366078AA SP LD FPM 93x12</p> <p>N:← 434.500 68093258AA A/BS RD FPM 30x45x7</p>	<p>TLS 651.340</p>
<p>VAS 191.420 04663904 (16x)</p>	<p>012.280 04777852AB</p> 	<p>486.040 04777847AV 4x</p> 	<p>a) 485.960 04777835AA</p> 	<p>K:← 583.050 04667198 AS RD FPM 32x45x6</p> <p>K:→ 902.760 04621939AB A/BS LD FPM 91x111x9</p>	
<p>VAS 708.100 FPM 026.650 FPM 16x</p> 	<p>012.280 04777852AB</p> 	<p>939.340 68317138AA 4x</p> 	<p>a) 485.960 04777835AA</p>  <p>b) 012.001 06507741AA M 14x1,5x20</p> <p>b) 176.090 13x22,4x3</p>	<p>K:← 583.050 04667198 AS RD FPM 32x45x6</p> <p>K:→ 902.760 04621939AB A/BS LD FPM 91x111x9</p>	
<p>506.550 68093294AA FPM 16x</p>	<p>907.400 68275163AA Euro 6</p> 	<p>AAS 340.470 68093452AA</p> 	<p>a) 030.793 Dirko HT</p> <p>b) 877.920 incl. 339.580 M 18x1,5x22</p> <p>b) 878.030 incl. 359.300 M 18x1,5x20</p> <p>b) 339.580 68098272AA CU A 18x26x1,5</p> <p>b) 359.300 FPM A 18x26x1,5 FE/FPM</p>	<p>K:← 069.590 68096793AA AW/BS RD FPM 31x41x7</p> <p>K:→ 199.191 68366078AA SP LD FPM 93x12</p> <p>N:← 434.500 68093258AA A/BS RD FPM 30x45x7</p>	

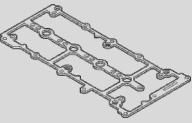



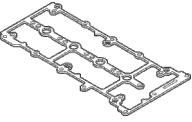



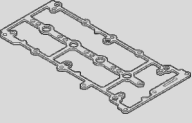







<p>CHRYSLER/ DODGE/JEEP</p> 				
<p>EJK</p> <p>4 Cyl. 1598 ccm Cyl. 79,5 Ø</p> <p>Renegade CRD 07/2014 →</p>	<p>ES⊕ 644.760</p>  <p>ES⊕ 926.670</p>  <p>CS* 926.680</p>	<p>789.180 0,82 mm $\frac{\pm}{\pm}$ 80,5 Ø</p>  <p>789.190 0,92 mm $\frac{\pm}{\pm}$ 80,5 Ø 1 ⊗</p>  <p>789.200 1,02 mm $\frac{\pm}{\pm}$ 80,5 Ø 2 ⊗</p> 	<p>ZKS 524.160 M 12x1,25x98</p> 	<p>748.591 68219780AA</p> 
<p>EJM</p> <p>4 Cyl. 1598 ccm Cyl. 77,0 Ø</p> <p>Neon 08/2016 →</p>	<p>CS* 903.590</p>		<p>ZKS 949.360 M 10x1,5x148</p>	<p>ZKHS 763.880 518.030</p> 
<p>EBF</p> <p>4 Cyl. 1747 ccm Cyl. 80,5 Ø</p> <p>Renegade 04/2015 →</p>	<p>CS* 903.590</p>		<p>ZKS 949.360 M 10x1,5x148</p>	<p>ZKHS 763.880 518.030</p> 
<p>EBA</p> <p>4 Cyl. 1798 ccm Cyl. 86,2 Ø</p> <p>Caliber 06/2006 → 12/2009</p>	<p>ES⊕ 656.370 CS* 528.970 CS* 656.420 05189957AD</p>	<p>783.160 5189975AB 86 Ø</p>	<p>ZKS 657.030 6508858AA (8x) 6508857AA (2x) M 11x1,5x165</p> 	<p>ZKHS 464.280</p>











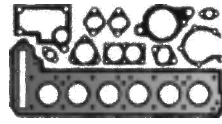
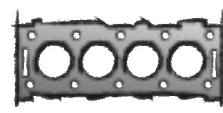

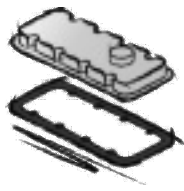

			<p>a) </p> <p>b) </p>	<p>K: </p> <p>N: </p>	
<p>506.550 68093294AA FPM 16x</p>	<p>907.400 68275163AA Euro 6</p> 	<p>AAS 340.470 68093452AA</p> 	<p>a) 030.793 Dirko HT</p> <p>b) 877.920 incl. 339.580 M 18x1,5x22</p> <p>b) 878.030 incl. 359.300 M 18x1,5x20</p> <p>b) 339.580 68098272AA CU A 18x26x1,5</p> <p>b) 359.300 FPM A 18x26x1,5 FE/FPM</p>	<p>K:← 069.590 68096793AA AW/BS RD FPM 31x41x7</p> <p>K:→ 199.191 68366078AA SP LD FPM 93x12</p> <p>N:← 434.500 68093258AA A/BS RD FPM 30x45x7</p>	<p>TLS 647.070 TLS 651.340</p>
<p>VAS 708.100 FPM 026.650 FPM 16x</p> 	<p>012.280 04777852AB</p> 	<p>939.340 68317138AA 4x</p> 	<p>a) 485.960 04777835AA</p>  <p>b) 012.001 06507741AA M 14x1,5x20</p> <p>b) 176.090 13x22,4x3</p>	<p>K:← 583.050 04667198 AS RD FPM 32x45x6</p> <p>K:→ 902.760 04621939AB A/BS LD FPM 91x111x9</p>	
<p>VAS 708.100 FPM 026.650 FPM 16x</p> 	<p>571.770</p>	<p>939.340 68317138AA 4x</p> 	<p>a) 485.960 04777835AA</p>  <p>b) 012.001 06507741AA M 14x1,5x20</p> <p>b) 176.090 13x22,4x3</p>	<p>K:← 583.050 04667198 AS RD FPM 32x45x6</p> <p>K:→ 902.760 04621939AB A/BS LD FPM 91x111x9</p>	
<p>429.320 2222425000 FPM 16x</p>		<p>464.050 4884550AB</p> 	<p>a) 036.164 Dirko HT / EU</p> <p>a) 510.031 Dirko HT / USA/CDN/MEX</p> <p>a) 527.291 Dirko HT / RU</p> <p>a) 648.661 Dirko HT / BR</p> <p>b) 012.001 06507741AA M 14x1,5x20</p> <p>b) 176.090 13x22,4x3</p>	<p>K:← 127.610 ASW RD FPM/ACM 42x55x7</p> <p>K:→ 034.560 AS LD FPM 85x103x8</p>	

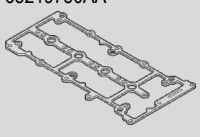

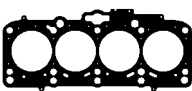
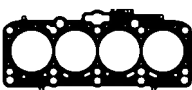
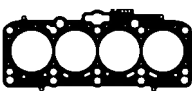

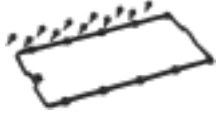
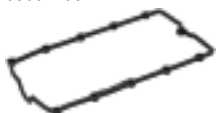

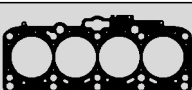
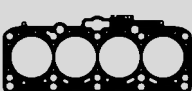
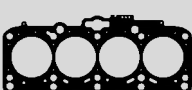

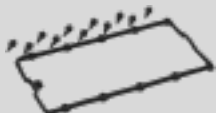
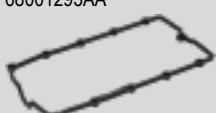







<p>CHRYSLER/ DODGE/JEEP</p> 				
<p>198 A5.000</p> <p>4 Cyl. 1956 ccm Cyl. 83,0 Ø</p> <p>Delta Multijet 08/2011 →</p>	<p>ES⊕ 693.880</p>  <p>CS* 592.910 CS 926.720</p>	<p>758.710 68263263AA  0,110 mm → 0,230 mm 0,95 mm $\frac{\pm}{\pm}$ 84 Ø</p> <p>758.680 68263096AA  0,231 mm → 0,330 mm 1,05 mm $\frac{\pm}{\pm}$ 84 Ø 1 ⊗</p> <p>758.690 68263264AA  0,331 mm → 0,425 mm 1,15 mm $\frac{\pm}{\pm}$ 84 Ø 2 ⊗</p>   	<p>ZKS 687.330 68092998AA (10x) M 12x1,25x219</p>	<p>748.591 68219780AA</p> 
<p>552 63 087</p> <p>4 Cyl. 1956 ccm Cyl. 83,0 Ø</p> <p>Compass CRD 03/2017 → Renegade CRD 07/2014 →</p>	<p>ES⊕ 687.350</p>  <p>CS 926.720</p>	<p>758.710 68263263AA  0,110 mm → 0,230 mm 0,95 mm $\frac{\pm}{\pm}$ 84 Ø</p> <p>758.680 68263096AA  0,231 mm → 0,330 mm 1,05 mm $\frac{\pm}{\pm}$ 84 Ø 1 ⊗</p> <p>758.690 68263264AA  0,331 mm → 0,425 mm 1,15 mm $\frac{\pm}{\pm}$ 84 Ø 2 ⊗</p>   	<p>ZKS 687.330 68092998AA (10x) M 12x1,25x219</p>	<p>748.591 68219780AA</p> 
<p>552 63 088</p> <p>4 Cyl. 1956 ccm Cyl. 83,0 Ø</p> <p>Commander CRD 10/2021 → Compass CRD 12/2016 → Compass Multijet 03/2017 → Renegade CRD 07/2014 →</p>	<p>ES⊕ 687.350</p>  <p>CS 926.720</p>	<p>758.710 68263263AA  0,110 mm → 0,230 mm 0,95 mm $\frac{\pm}{\pm}$ 84 Ø</p> <p>758.680 68263096AA  0,231 mm → 0,330 mm 1,05 mm $\frac{\pm}{\pm}$ 84 Ø 1 ⊗</p> <p>758.690 68263264AA  0,331 mm → 0,425 mm 1,15 mm $\frac{\pm}{\pm}$ 84 Ø 2 ⊗</p>   	<p>ZKS 687.330 68092998AA (10x) M 12x1,25x219</p>	<p>748.591 68219780AA</p> 











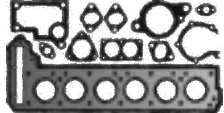
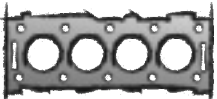

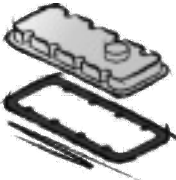

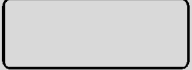









			<p>a) </p> <p>b) </p>	<p>K: </p> <p>N: </p>	
<p>506.550 68093294AA FPM 16x</p>	<p>748.510 </p>	<p>AAS 340.470 68093452AA </p>	<p>a) 030.793 Dirko HT</p> <p>b) 877.920 incl. 339.580 M 18x1,5x22</p> <p>b) 878.030 incl. 359.300 M 18x1,5x20</p> <p>b) 339.580 68098272AA CU A 18x26x1,5</p> <p>b) 359.300 FPM A 18x26x1,5 FE/FPM</p>	<p>K:← 069.590 68096793AA AW/BS RD FPM 31x41x7</p> <p>K:→ 199.191 68366078AA SP LD FPM 93x12</p> <p>N:← 434.500 68093258AA A/BS RD FPM 30x45x7</p>	
<p>506.550 68093294AA FPM 16x</p>	<p>748.530 68093456AA Euro 5 </p> <p>907.400 68275163AA Euro 6 </p>	<p>AAS 340.470 68093452AA </p>	<p>a) 030.793 Dirko HT</p> <p>b) 877.920 incl. 339.580 M 18x1,5x22</p> <p>b) 878.030 incl. 359.300 M 18x1,5x20</p> <p>b) 339.580 68098272AA CU A 18x26x1,5</p> <p>b) 359.300 FPM A 18x26x1,5 FE/FPM</p>	<p>K:← 069.590 68096793AA AW/BS RD FPM 31x41x7</p> <p>K:→ 199.191 68366078AA SP LD FPM 93x12</p> <p>N:← 434.500 68093258AA A/BS RD FPM 30x45x7</p>	<p>TLS 803.330 Renegade BU</p>
<p>506.550 68093294AA FPM 16x</p>	<p>748.530 68093456AA Euro 5 </p> <p>907.400 68275163AA Euro 6 </p>	<p>AAS 340.470 68093452AA </p>	<p>a) 030.793 Dirko HT</p> <p>b) 877.920 incl. 339.580 M 18x1,5x22</p> <p>b) 878.030 incl. 359.300 M 18x1,5x20</p> <p>b) 339.580 68098272AA CU A 18x26x1,5</p> <p>b) 359.300 FPM A 18x26x1,5 FE/FPM</p>	<p>K:← 069.590 68096793AA AW/BS RD FPM 31x41x7</p> <p>K:→ 199.191 68366078AA SP LD FPM 93x12</p> <p>N:← 434.500 68093258AA A/BS RD FPM 30x45x7</p>	<p>TLS 803.330 Commander 671 Renegade BU</p>













<p>CHRYSLER/ DODGE/JEEP</p> 				
<p>552 83 099 552 84 064</p> <p>4 Cyl. 1956 ccm Cyl. 83,0 Ø</p> <p>Renegade CRD 07/2014 →</p>	<p>ES⊕ 687.350</p>  <p>CS 926.720</p>	<p>758.710 68263263AA  0,110 mm → 0,230 mm 0,95 mm $\frac{1}{2}$ 84 Ø</p> <p>758.680 68263096AA  0,231 mm → 0,330 mm 1,05 mm $\frac{1}{2}$ 84 Ø 1 ⊗</p> <p>758.690 68263264AA  0,331 mm → 0,425 mm 1,15 mm $\frac{1}{2}$ 84 Ø 2 ⊗</p>	<p>ZKS 687.330 68092998AA (10x) M 12x1,25x219</p>	<p>748.591 68219780AA</p> 
<p>EBS</p> <p>4 Cyl. 1956 ccm Cyl. 83,0 Ø</p> <p>Cherokee CRD 04/2014 → 08/2018</p> <p>Compass CRD 12/2016 →</p> <p>Compass Multijet 03/2017 →</p>	<p>ES⊕ 687.350</p>  <p>CS 926.720</p>	<p>758.710 68263263AA  0,110 mm → 0,230 mm 0,95 mm $\frac{1}{2}$ 84 Ø</p> <p>758.680 68263096AA  0,231 mm → 0,330 mm 1,05 mm $\frac{1}{2}$ 84 Ø 1 ⊗</p> <p>758.690 68263264AA  0,331 mm → 0,425 mm 1,15 mm $\frac{1}{2}$ 84 Ø 2 ⊗</p>	<p>ZKS 687.330 68092998AA (10x) M 12x1,25x219</p>	<p>748.591 68219780AA</p> 
<p>EBT</p> <p>4 Cyl. 1956 ccm Cyl. 83,0 Ø</p> <p>Cherokee CRD 04/2014 → 08/2018</p> <p>Compass CRD 03/2017 →</p> <p>Compass Multijet 03/2017 →</p> <p>Renegade CRD 07/2014 →</p>	<p>ES⊕ 687.350</p>  <p>CS 926.720</p>	<p>758.710 68263263AA  0,110 mm → 0,230 mm 0,95 mm $\frac{1}{2}$ 84 Ø</p> <p>758.680 68263096AA  0,231 mm → 0,330 mm 1,05 mm $\frac{1}{2}$ 84 Ø 1 ⊗</p> <p>758.690 68263264AA  0,331 mm → 0,425 mm 1,15 mm $\frac{1}{2}$ 84 Ø 2 ⊗</p>	<p>ZKS 687.330 68092998AA (10x) M 12x1,25x219</p>	<p>748.591 68219780AA</p> 







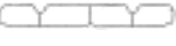



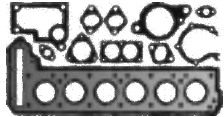
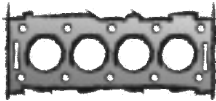

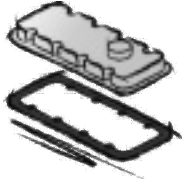





			<p>a) </p> <p>b) </p>	<p>K: </p> <p>N: </p>	
<p>506.550 68093294AA FPM 16x</p>	<p>748.530 68093456AA Euro 5  907.400 68275163AA Euro 6 </p>	<p>AAS 340.470 68093452AA </p>	<p>a) 030.793 Dirko HT</p> <p>b) 877.920 incl. 339.580 M 18x1,5x22</p> <p>b) 878.030 incl. 359.300 M 18x1,5x20</p> <p>b) 339.580 68098272AA CU A 18x26x1,5</p> <p>b) 359.300 FPM A 18x26x1,5 FE/FPM</p>	<p>K:← 069.590 68096793AA AW/BS RD FPM 31x41x7</p> <p>K:→ 199.191 68366078AA SP LD FPM 93x12</p> <p>N:← 434.500 68093258AA A/BS RD FPM 30x45x7</p>	
<p>506.550 68093294AA FPM 16x</p>	<p>748.530 68093456AA Euro 5 </p>	<p>AAS 340.470 68093452AA </p>	<p>a) 030.793 Dirko HT</p> <p>b) 877.920 incl. 339.580 M 18x1,5x22</p> <p>b) 878.030 incl. 359.300 M 18x1,5x20</p> <p>b) 339.580 68098272AA CU A 18x26x1,5</p> <p>b) 359.300 FPM A 18x26x1,5 FE/FPM</p>	<p>K:← 069.590 68096793AA AW/BS RD FPM 31x41x7</p> <p>K:→ 199.191 68366078AA SP LD FPM 93x12</p> <p>N:← 434.500 68093258AA A/BS RD FPM 30x45x7</p>	<p>TLS 940.491 Cherokee KL</p>
<p>506.550 68093294AA FPM 16x</p>	<p>748.530 68093456AA Euro 5  907.400 68275163AA Euro 6 </p>	<p>AAS 340.470 68093452AA </p>	<p>a) 030.793 Dirko HT</p> <p>b) 877.920 incl. 339.580 M 18x1,5x22</p> <p>b) 878.030 incl. 359.300 M 18x1,5x20</p> <p>b) 339.580 68098272AA CU A 18x26x1,5</p> <p>b) 359.300 FPM A 18x26x1,5 FE/FPM</p>	<p>K:← 069.590 68096793AA AW/BS RD FPM 31x41x7</p> <p>K:→ 199.191 68366078AA SP LD FPM 93x12</p> <p>N:← 434.500 68093258AA A/BS RD FPM 30x45x7</p>	<p>TLS 803.330 Renegade BU TLS 940.491 Cherokee KL</p>





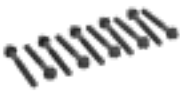











<p>CHRYSLER/ DODGE/JEEP</p> 				
<p>EBT</p> <p>4 Cyl. 1956 ccm Cyl. 83,0 Ø</p> <p>Journey CRD 01/2012 →</p>	<p>ES⊕ 687.350</p>  <p>CS 926.720</p>	<p>758.710 68263263AA  0,110 mm → 0,230 mm 0,95 mm $\frac{\pm}{\pm}$ 84 Ø</p> <p>758.680 68263096AA  0,231 mm → 0,330 mm 1,05 mm $\frac{\pm}{\pm}$ 84 Ø 1 ⊗</p> <p>758.690 68263264AA  0,331 mm → 0,425 mm 1,15 mm $\frac{\pm}{\pm}$ 84 Ø 2 ⊗</p>	<p>ZKS 687.330 68092998AA (10x) M 12x1,25x219</p>	<p>748.591 68219780AA</p> 
<p>ECD</p> <p>4 Cyl. 1968 ccm Cyl. 81,0 Ø</p> <p>Avenger CRD 06/2007 → 12/2011</p> <p>Caliber CRD 06/2006 →</p> <p>Compass CRD 08/2006 →</p> <p>Patriot CRD 02/2007 → 12/2017</p> <p>Sebring CRD 07/2007 → 12/2010</p>	<p>ES⊕ 490.921</p>  <p>CS* 735.690</p>	<p>150.380 68033096AA  0,910 mm → 1,000 mm 1,55 mm $\frac{\pm}{\pm}$ 82 Ø 1 ⊗</p> <p>150.390 68033094AA  1,010 mm → 1,100 mm 1,63 mm $\frac{\pm}{\pm}$ 82 Ø 2 ⊗</p> <p>150.400 68001272AA  1,110 mm → 1,200 mm 1,71 mm $\frac{\pm}{\pm}$ 82 Ø 3 ⊗</p>	<p>ZKS 305.430 M 12x1,75x152</p> 	<p>ZKHS 388.930</p>  <p>005.911 68001293AA</p>  <p>461.682 EL-Liq 74 ↓</p>
<p>ECE</p> <p>4 Cyl. 1968 ccm Cyl. 81,0 Ø</p> <p>Caliber CRD 06/2006 →</p> <p>Compass CRD 08/2006 →</p> <p>Journey CRD 06/2008 →</p> <p>Patriot CRD 02/2007 → 12/2017</p>	<p>ES⊕ 490.921</p>  <p>CS* 735.690</p>	<p>150.380 68033096AA  0,910 mm → 1,000 mm 1,55 mm $\frac{\pm}{\pm}$ 82 Ø 1 ⊗</p> <p>150.390 68033094AA  1,010 mm → 1,100 mm 1,63 mm $\frac{\pm}{\pm}$ 82 Ø 2 ⊗</p> <p>150.400 68001272AA  1,110 mm → 1,200 mm 1,71 mm $\frac{\pm}{\pm}$ 82 Ø 3 ⊗</p>	<p>ZKS 305.430 M 12x1,75x152</p> 	<p>ZKHS 388.930</p>  <p>005.911 68001293AA</p>  <p>461.682 EL-Liq 74 ↓</p>





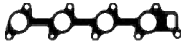

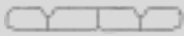

			<p>a) </p> <p>b) </p>	<p>K: </p> <p>N: </p>	
<p>506.550 68093294AA FPM 16x</p>	<p>748.530 68093456AA Euro 5  907.400 68275163AA Euro 6 </p>	<p>AAS 340.470 68093452AA </p>	<p>a) 030.793 Dirko HT</p> <p>b) 877.920 incl. 339.580 M 18x1,5x22</p> <p>b) 878.030 incl. 359.300 M 18x1,5x20</p> <p>b) 339.580 68098272AA CU A 18x26x1,5</p> <p>b) 359.300 FPM A 18x26x1,5 FE/FPM</p>	<p>K:← 069.590 68096793AA AW/BS RD FPM 31x41x7</p> <p>K:→ 199.191 68366078AA SP LD FPM 93x12</p> <p>N:← 434.500 68093258AA A/BS RD FPM 30x45x7</p>	<p>TLS 940.491</p>
<p>VAS 235.610 FPM</p> <p>724.590 68001551AA FPM 16x</p>	<p>477.640 68000634AA </p>	<p>477.630 68001462AB </p>	<p>a) 030.793 Dirko HT</p> <p>b) 567.640 M 14x1,5x22</p>	<p>K:← 155.560 68000666AA ASW RD PTFE/ACM 35x48x10</p> <p>K:→ 430.190 68000669AA IWD LD PTFE 85</p> <p>N:← 129.780 68001164AA ASW RD PTFE/ACM 32x47x10</p>	<p>TLS 740.790 </p>
<p>VAS 235.610 FPM</p> <p>724.590 68001551AA FPM 16x</p>	<p>733.350 68021543AA </p>	<p>477.630 68001462AB </p>	<p>a) 030.793 Dirko HT</p> <p>b) 567.640 M 14x1,5x22</p>	<p>K:← 155.560 68000666AA ASW RD PTFE/ACM 35x48x10</p> <p>K:→ 430.190 68000669AA IWD LD PTFE 85</p> <p>N:← 129.780 68001164AA ASW RD PTFE/ACM 32x47x10</p>	

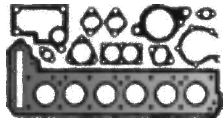
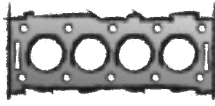

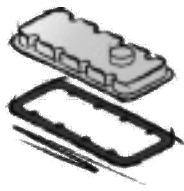







<p>CHRYSLER/ DODGE/JEEP</p> 				
<p>J5R-800 4 Cyl. 1995 ccm Cyl. 88,0 Ø</p> <p>CJ5 - CJ8 01/1983 → 12/1987</p>		<p>984.704 1,27 mm $\frac{1}{2}$ 89 Ø</p> 		<p>144.750</p> 
<p>ECN 4 Cyl. 1998 ccm Cyl. 86,0 Ø</p> <p>Avenger 06/2007 → 12/2011</p> <p>Caliber 06/2006 →</p> <p>Compass 08/2006 →</p> <p>Patriot 02/2007 → 12/2017</p> <p>Sebring 07/2007 → 12/2010</p>	<p>ES⊕ 656.370 CS* 528.970 CS* 656.420 05189957AD</p>	<p>783.160 5189975AB 86 Ø</p>	<p>ZKS 657.030 6508858AA (8x) 6508857AA (2x) M 11x1,5x165</p> 	<p>ZKHS 464.280</p>
<p>J8S J8S 742 4 Cyl. 2068 ccm Cyl. 86,0 Ø</p> <p>Cherokee TD 10/1984 → 09/2001</p>	<p>S⊕* 309.000 </p> <p>ES⊕ 711.730 T1461765 </p> <p>CS* 984.604 T1461334</p>	<p>446.363 ● T0128289  → 0,960 mm 1,59 mm $\frac{1}{2}$ 87 Ø 1 ⊕</p> <p>446.373 T0711666  → 0,960 mm → 1,040 mm 1,69 mm $\frac{1}{2}$ 87 Ø</p> <p>446.383 T1028290  → 1,040 mm → 1,80 mm $\frac{1}{2}$ 87 Ø 2 ⊕</p>   		<p>421.120 T0662455 →09/1990 </p> <p>523.181 J0743953 09/1990 → </p>
<p>J8S J8S 890 J8S-800/814/890 4 Cyl. 2068 ccm Cyl. 86,0 Ø</p> <p>CJ5 - CJ8 Diesel 01/1983 → 12/1987</p> <p>Comanche TD 01/1986 → 09/1990</p>	<p>S⊕* 309.000 </p> <p>ES⊕ 711.730 T1461765 </p> <p>CS* 984.604 T1461334</p>	<p>446.363 ● T0128289  → 0,960 mm 1,59 mm $\frac{1}{2}$ 87 Ø 1 ⊕</p> <p>446.373 T0711666  → 0,960 mm → 1,040 mm 1,69 mm $\frac{1}{2}$ 87 Ø</p> <p>446.383 T1028290  → 1,040 mm → 1,80 mm $\frac{1}{2}$ 87 Ø 2 ⊕</p>   		<p>421.120 T0662455 </p>







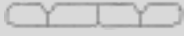



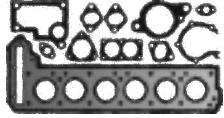
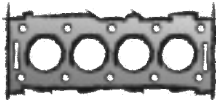

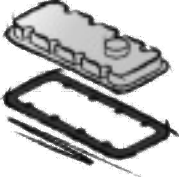









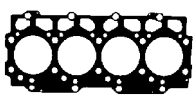

			<p>a) </p> <p>b) </p>	<p>K: </p> <p>N: </p>	
<p>VAS 294.250 FPM 294.110 T1349529 FPM 8x</p>	<p>420.730 </p>		<p>b) 813.052 T7777649 CU C 16x22x2</p>	<p>K:← 508.470 T1349595 ASW RD FPM/ACM 50x68x8 K:→ 511.064 T1349596 ASW LD FPM/ACM 90x110x11 N:← 504.483 T1349626 AW RD FPM/ACM 35x47x7</p>	
<p>429.320 2222425000 FPM 16x</p>	<p>428.210 1555A185 </p>	<p>464.050 4884550AB </p>	<p>a) 036.164 Dirko HT / EU a) 510.031 Dirko HT / USA/CDN/MEX a) 527.291 Dirko HT / RU a) 648.661 Dirko HT / BR b) 298.480 06506214AA M 14x1,5x18</p>	<p>K:← 127.610 ASW RD FPM/ACM 42x55x7 K:→ 034.560 AS LD FPM 85x103x8</p>	
<p>VAS 294.250 FPM 294.110 T1349529 FPM 8x</p>		<p>985.385 T0694729 4x </p>	<p>b) 813.052 T7777649 CU C 16x22x2</p>	<p>K:← 508.470 T1349595 ASW RD FPM/ACM 50x68x8 K:→ 511.064 T1349596 ASW LD FPM/ACM 90x110x11 N:← 504.483 T1349626 AW RD FPM/ACM 35x47x7</p>	
<p>VAS 294.250 FPM 294.110 T1349529 FPM 8x</p>		<p>985.385 T0694729 4x </p>	<p>b) 813.052 T7777649 CU C 16x22x2</p>	<p>K:← 508.470 T1349595 ASW RD FPM/ACM 50x68x8 K:→ 511.064 T1349596 ASW LD FPM/ACM 90x110x11 N:← 504.483 T1349626 AW RD FPM/ACM 35x47x7</p>	









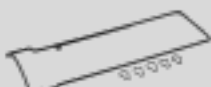







CHRYSLER/ DODGE/JEEP  Das Original				
ENE 4 Cyl. 2143 ccm Cyl. 83,0 Ø Caliber CRD 07/2010 → 11/2011 Compass CRD 05/2011 → Patriot CRD 01/2011 → 12/2017	ES⊕ 906.380 CS* 006.600 OKS 867.720 	732.640 1,35 mm $\frac{\pm}{\pm}$ 84 Ø  529.530 1,55 mm $\frac{\pm}{\pm}$ 84 Ø 	ZKS 584.500 M 12x1,5x226 	719.800 68089272AA 
EDJ 4 Cyl. 2148 ccm Cyl. 88,0 Ø PT Cruiser 10/2002 → 08/2008 PT Cruiser CRD 03/2002 → 12/2010	ES⊕ 948.510  CS* 267.000	762.811 05080162AA  0,380 mm → 0,620 mm 1,20 mm $\frac{\pm}{\pm}$ 88,8 Ø  374.880  0,380 mm → 0,620 mm 1,20 mm $\frac{\pm}{\pm}$ 89,3 Ø  612.282 1,40 mm $\frac{\pm}{\pm}$ 88,8 Ø 1 ▽  374.891 1,40 mm $\frac{\pm}{\pm}$ 89,3 Ø 	ZKS 760.090 05073921AA (10x) M 12x1,75x102 	ZKHS 940.520 890.800 5080170AA 
ED3 4 Cyl. 2360 ccm Cyl. 88,0 Ø 200 01/2011 → 12/2014 Avenger 06/2007 → 12/2014 Caliber 10/2006 → Cirrus 09/2006 → 12/2010 Compass 08/2006 → Journey 09/2008 → Patriot 02/2007 → 12/2017 Sebring 07/2007 → 12/2010	ES⊕ 448.390 5189956AB CS* 528.970 CS* 656.420 05189957AD	448.440 5189976AB 0,50 mm $\frac{\pm}{\pm}$ 89 Ø	ZKS 657.030 6508858AA (8x) 6508857AA (2x) M 11x1,5x165 	ZKHS 464.280
ED4 4 Cyl. 2360 ccm Cyl. 88,0 Ø Caliber 10/2006 →	CS* 528.970 CS* 656.420 05189957AD		ZKS 657.030 6508858AA (8x) 6508857AA (2x) M 11x1,5x165 	ZKHS 464.280





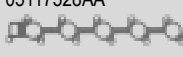





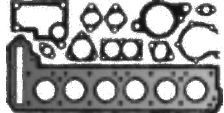
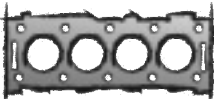

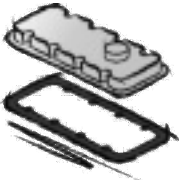

			<p>a) </p> <p>b) </p>	<p>K: </p> <p>N: </p>	
<p>VAS 424.800 FPM 403.730 68001551AA FPM 16x</p>	<p>387.662 0,71 mm $\frac{1}{16}$</p>  <p>690.721 68091839AA 0,91 mm $\frac{1}{16}$</p> 	<p>719.790 68089608AA</p> 	<p>a) 719.780 68091842AA</p>  <p>b) 877.840 incl. 115.100 M 14x1,5x33</p> <p>b) 115.100 05073946AA CU A 14x20x1,5</p>	<p>K:← 742.950 68089211AA ASW OF RD FPM 60x75x8</p> <p>K:→ 588.620 ASW OF LD FPM 96x114x8,5</p> <p>K:→ 742.960 68089220AA AW/BS OF LD FPM 96x114x9</p>	<p>TLS 455.220</p> 
<p>VAS 413.470 830.489 05080056AA FPM 16x</p>	<p>432.894 5080393AB</p> 	<p>907.560 5080385AA</p>	<p>a) 175.143 05073947AA</p>  <p>b) 115.100 05073946AA CU A 14x20x1,5</p>	<p>K:← 424.841 05073675AB ASW RD PTFE/ACM 45x67x8</p> <p>K:→ 746.400 05073887AB SP LD PTFE 93</p>	
<p>429.320 2222425000 FPM 16x</p>	<p>428.210 1555A185</p> 	<p>464.050 4884550AB</p> 	<p>a) 036.164 Dirko HT / EU</p> <p>a) 510.031 Dirko HT / USA/CDN/MEX</p> <p>a) 527.291 Dirko HT / RU</p> <p>a) 648.661 Dirko HT / BR</p> <p>b) 298.480 06506214AA M 14x1,5x18</p>	<p>K:← 127.610 ASW RD FPM/ACM 42x55x7</p> <p>K:→ 034.560 AS LD FPM 85x103x8</p>	
<p>429.320 2222425000 FPM 16x</p>		<p>464.050 4884550AB</p> 	<p>a) 036.164 Dirko HT / EU</p> <p>a) 510.031 Dirko HT / USA/CDN/MEX</p> <p>a) 527.291 Dirko HT / RU</p> <p>a) 648.661 Dirko HT / BR</p> <p>b) 298.480 06506214AA M 14x1,5x18</p>	<p>K:← 127.610 ASW RD FPM/ACM 42x55x7</p> <p>K:→ 034.560 AS LD FPM 85x103x8</p>	









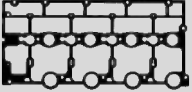



<p>CHRYSLER/ DODGE/JEEP</p> 				
<p>EDG</p> <p>4 Cyl. 2360 ccm Cyl. 88,0 Ø</p> <p>200 01/2011 →</p> <p>Avenger 06/2007 → 12/2014</p> <p>Caliber 09/2007 → 12/2012</p> <p>Compass 08/2006 →</p> <p>Journey 06/2008 →</p> <p>Patriot 01/2008 → 12/2017</p> <p>Sebring 09/2006 → 12/2010</p>	<p>CS* 528.970 CS* 656.420 05189957AD</p>	<p>448.440 5189976AB 0,50 mm $\frac{1}{32}$ 89 Ø</p>	<p>ZKS 657.030 6508858AA (8x) 6508857AA (2x) M 11x1,5x165</p> 	<p>ZKHS 464.280</p>
<p>EDK ENJ R 425 DOHC</p> <p>4 Cyl. 2499 ccm Cyl. 92,0 Ø</p> <p>Cherokee CRD 09/2001 → 01/2008</p> <p>Grand Voyager CRD 01/2001 → 02/2008</p> <p>RAM CRD 03/2002 → 04/2008</p> <p>Voyager CRD 02/2000 → 12/2008</p>		<p>689.726 05072675AA  0,460 mm → 0,609 mm 1,32 mm $\frac{1}{16}$</p> <p>690.396 05072676AA  0,610 mm → 0,709 mm 1,42 mm $\frac{1}{8}$ 1 ⊗</p> <p>690.426 05072677AA  0,710 mm → 0,810 mm 1,52 mm $\frac{1}{8}$ 2 ⊗</p>		<p>753.130 05066786AA</p> 









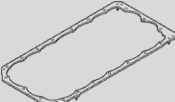

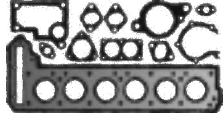
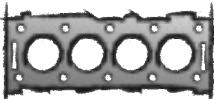
			<p>a) </p> <p>b) </p>	<p>K: </p> <p>N: </p>	
<p>429.320 2222425000 FPM 16x</p>		<p>464.050 4884550AB</p> 	<p>a) 036.164 Dirko HT / EU</p> <p>a) 510.031 Dirko HT / USA/CDN/MEX</p> <p>a) 527.291 Dirko HT / RU</p> <p>a) 648.661 Dirko HT / BR</p> <p>b) 298.480 06506214AA M 14x1,5x18</p>	<p>K:← 127.610 ASW RD FPM/ACM 42x55x7</p> <p>K:→ 034.560 AS LD FPM 85x103x8</p>	
	<p>788.850 05093904AA</p> 		<p>a) 690.531 05066901AA</p>  <p>b) 057.370 3/8"x10</p> <p>b) 108.540 3/8"x10</p> <p>b) 120.782 04720353 CU A 17x21x1,5</p>	<p>K:← 298.770 AW RD PTFE/ACM 56x70,25x8,2</p>	

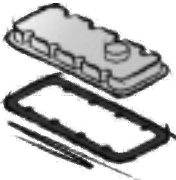











<p>CHRYSLER/ DODGE/JEEP</p>  <p>Das Original</p>				
<p>425 CLIRS/X ENC HR 425 CLI HR425 M51 M52 VM HR 425 CLIEE</p> <p>4 Cyl. 2499 ccm Cyl. 92,0 Ø</p> <p>Caravan TD 01/1995 → 03/2001</p> <p>Cherokee TD 01/1988 → 09/2001</p> <p>Dakota 10/1998 → 12/2001</p> <p>Grand Caravan 02/2006 → 05/2007</p> <p>Grand Cherokee TD 10/1995 → 04/1999</p> <p>Grand Voyager 01/1995 → 03/2001</p> <p>RAM TD 06/1995 → 10/2002</p> <p>Voyager TD 01/1992 → 03/2001</p> <p>Voyager TDiC 10/1995 → 03/2001</p>	<p>ES⊕ 504.080</p> 	<p>521.339 1,48 mm $\frac{\pm}{\pm}$ 4x</p>  <p>521.347 1,59 mm $\frac{\pm}{\pm}$ 2 ▽ 4x</p>  <p>521.355 1,69 mm $\frac{\pm}{\pm}$ 1 ▽ 4x</p>  <p>164.861 ● 04863782 1,52 mm $\frac{\pm}{\pm}$ 98 Ø</p>  <p>164.841 04863783 1,62 mm $\frac{\pm}{\pm}$ 98 Ø</p> 		<p>446.111 04863789AC</p> 
<p>09B M00</p> <p>4 Cyl. 2500 ccm Cyl. 92,0 Ø</p> <p>Voyager TD 01/1992 → 09/1995</p>	<p>ES 418.130</p> 	<p>521.339 1,48 mm $\frac{\pm}{\pm}$ 4x</p>  <p>521.347 1,59 mm $\frac{\pm}{\pm}$ 2 ▽ 4x</p>  <p>521.355 1,69 mm $\frac{\pm}{\pm}$ 1 ▽ 4x</p>  <p>164.861 ● 04863782 1,52 mm $\frac{\pm}{\pm}$ 98 Ø</p>  <p>164.841 04863783 1,62 mm $\frac{\pm}{\pm}$ 98 Ø</p> 		<p>200.941</p> 
<p>EX8</p> <p>5 Cyl. 2685 ccm Cyl. 88,0 Ø</p> <p>Sprinter 2500 09/2003 → 12/2006</p> <p>Sprinter 3500 09/2002 → 12/2006</p>	<p>S⊕* 531.381 → Mot. 50 813930</p>  <p>S⊕ 381.150 Mot. 50 813931→</p>  <p>ES 375.550</p>  <p>CS* 633.330</p>	<p>612.332 1,40 mm $\frac{\pm}{\pm}$ 88,8 Ø</p>  <p>376.400 1,40 mm $\frac{\pm}{\pm}$ 89,3 Ø</p>  <p>762.821 05134783AA → 0,380 mm → 0,620 mm 1,20 mm $\frac{\pm}{\pm}$ 88,8 Ø</p> 	<p>ZKS 760.120 05073921AA (12x) M 12x1,75x102</p> 	<p>ZKHS 330.370 → Mot. 50 813930</p>  <p>ZKHS 685.330 Mot. 50 813931→</p> 











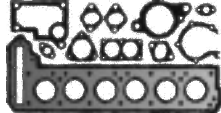
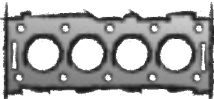

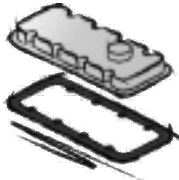

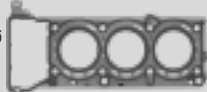

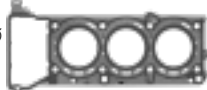

			<p>a) </p> <p>b) </p>	<p>K: </p> <p>N: </p>	
<p>104.380 FPM 8x</p>	<p>435.830 4x</p> 	<p>435.810 4x</p> 	<p>a) 036.164 Dirko HT / EU</p> <p>a) 510.031 Dirko HT / USA/CDN/MEX</p> <p>a) 527.291 Dirko HT / RU</p> <p>a) 648.661 Dirko HT / BR</p> <p>b) 057.370 3/8"x10</p> <p>b) 108.540 3/8"x10</p> <p>b) 120.782 04720353 CU A 17x21x1,5</p>	<p>K:← 501.123 ASW RD ACM 52x68x8</p> <p>K:→ 298.247 05010817AA ASW LD FPM/ACM 110x130x13</p>	
	<p>435.830 4x</p> 	<p>435.810 4x</p> 	<p>b) 057.370 3/8"x10</p> <p>b) 108.540 3/8"x10</p> <p>b) 120.782 04720353 CU A 17x21x1,5</p>	<p>K:← 501.123 ASW RD ACM 52x68x8</p> <p>K:→ 298.247 05010817AA ASW LD FPM/ACM 110x130x13</p>	
<p>VAS 687.510 830.489 05080056AA FPM 20x</p>	<p>432.924 05117528AA</p> 	<p>433.113</p> 	<p>a) 490.654 05175310AA</p>  <p>b) 877.840 incl. 115.100 M 14x1,5x33</p> <p>b) 115.100 05073946AA CU A 14x20x1,5</p>	<p>K:← 424.841 05073675AB ASW RD PTFE/ACM 45x67x8</p> <p>K:→ 746.400 05073887AB SP LD PTFE 93</p>	<p>TLS 715.740</p> 







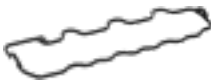











<p>CHRYSLER/ DODGE/JEEP</p> 				
<p>OM 665.921</p> <p>5 Cyl. 2685 ccm Cyl. 88,0 Ø</p> <p>Grand Cherokee CRD 10/2001 → 09/2005</p>	<p>ES 024.081</p>  <p>ES⊕ 554.931</p>  <p>CS* 633.330</p>	<p>612.332 1,40 mm $\frac{\pm}{\pm}$ 88,8 Ø </p> <p>376.400 1,40 mm $\frac{\pm}{\pm}$ 89,3 Ø </p> <p>762.821 05134783AA  → 0,380 mm → 0,620 mm 1,20 mm $\frac{\pm}{\pm}$ 88,8 Ø</p>	<p>ZKS 760.120 05073921AA (12x) M 12x1,75x102</p> 	<p>ZKHS 330.370</p> 
<p>EER EES</p> <p>6 Cyl. 2736 ccm Cyl. 86,0 Ø</p> <p>300 C 09/2004 → 11/2012</p> <p>300 M 11/1998 → 09/2004</p> <p>Avenger 06/2007 → 12/2011</p> <p>Charger 04/2006 → 12/2010</p> <p>Cirrus 09/2000 → 12/2006</p> <p>Concorde 10/1997 → 09/2003</p> <p>Intrepid 09/1997 → 09/2004</p> <p>Journey 11/2008 →</p> <p>Magnum 09/2005 → 12/2008</p> <p>Sebring 01/2001 → 12/2010</p> <p>Stratus 09/2000 → 10/2006</p>		<p>512.850 4792931AC L </p> <p>512.930 4792932AC R</p>		
<p>ENR</p> <p>4 Cyl. 2777 ccm Cyl. 94,0 Ø</p> <p>Cherokee CRD 11/2002 → 01/2008</p> <p>Grand Voyager CRD 04/2004 → 02/2008</p> <p>Nitro CRD 10/2006 → 12/2012</p> <p>RAM CRD 06/2004 → 07/2009</p> <p>Voyager CRD 06/2004 → 12/2008</p>		<p>689.726 05072675AA  0,460 mm → 0,609 mm 1,32 mm $\frac{\pm}{\pm}$</p> <p>690.396 05072676AA  0,610 mm → 0,709 mm 1,42 mm $\frac{\pm}{\pm}$ 1 ⊗</p> <p>690.426 05072677AA  0,710 mm → 0,810 mm 1,52 mm $\frac{\pm}{\pm}$ 2 ⊗</p>		<p>753.130 05066786AA</p> 









			<p>a) </p> <p>b) </p>	<p>K: </p> <p>N: </p>	
<p>VAS 687.510 830.489 05080056AA FPM 20x</p>	<p>432.924 05117528AA </p>		<p>a) 490.654 05175310AA </p> <p>b) 115.100 05073946AA CU A 14x20x1,5</p>	<p>K:← 424.841 05073675AB ASW RD PTFE/ACM 45x67x8</p> <p>K:→ 746.400 05073887AB SP LD PTFE 93</p>	<p>TLS 715.740 </p>
			<p>b) 012.001 06507741AA M 14x1,5x20</p> <p>b) 298.480 06506214AA M 14x1,5x18</p> <p>b) 176.090 13x22,4x3</p>		
	<p>788.850 05093904AA </p>		<p>a) 690.531 05066901AA </p> <p>b) 057.370 3/8"x10</p> <p>b) 108.540 3/8"x10</p> <p>b) 120.782 04720353 CU A 17x21x1,5</p>	<p>K:← 298.770 AW RD PTFE/ACM 56x70,25x8,2</p>	

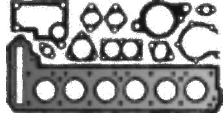
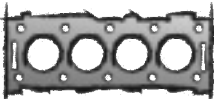

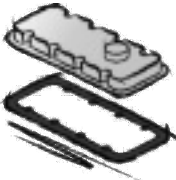
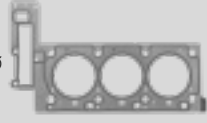
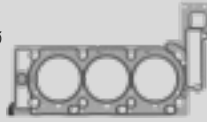

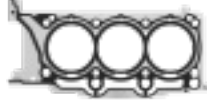
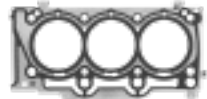









<p>CHRYSLER/ DODGE/JEEP</p> 				
<p>ENS</p> <p>4 Cyl. 2777 ccm Cyl. 94,0 Ø</p> <p>Cherokee CRD 05/2008 →</p> <p>Grand Voyager CRD 10/2007 →</p> <p>Nitro CRD 10/2006 → 12/2012</p> <p>Wrangler CRD 04/2007 →</p>	<p>ES⊕ 306.081 →07/2011</p>  <p>CS 335.600</p>	<p>137.681 68031476AA</p>  <p>→ 0,400 mm → 0,499 mm</p> <p>1,20 mm $\frac{+}{-}$ 95 Ø 1 ⊗</p> <p>137.761 68031477AA</p>  <p>→ 0,500 mm → 0,599 mm</p> <p>1,30 mm $\frac{+}{-}$ 95 Ø 2 ⊗</p>	<p>ZKS 906.110 68027567 (10x) M 14x1,5x155</p> 	
<p>300 6G72 6G72 (SOHC 12V) EFA</p> <p>6 Cyl. 2972 ccm Cyl. 91,1 Ø</p> <p>Acclaim 09/1988 → 09/1995</p> <p>Caravan 10/1988 → 06/2000</p> <p>Daytona 09/1989 → 12/1993</p> <p>Dynasty 09/1988 → 12/1993</p> <p>Grand Caravan 09/1986 → 12/2000</p> <p>Le Baron 01/1990 → 12/1996</p> <p>Mini Ram 09/1986 → 12/1988</p> <p>New Yorker 09/1988 → 12/1989</p> <p>Raider 09/1988 → 12/1989</p> <p>RAM 50 09/1989 → 12/1991</p> <p>Saratoga 09/1989 → 12/1995</p> <p>Shadow 09/1991 → 12/1994</p> <p>Spirit 09/1988 → 12/1995</p> <p>Stealth 09/1990 → 12/1996</p> <p>Sundance 10/1991 → 09/1994</p> <p>Voyager 09/1986 → 03/2001</p>		<p>540.470 MD301566 MD143540</p>  <p>1,30 mm $\frac{+}{-}$ 93 Ø 2x</p>		<p>ZKHS 339.250 2x</p>  <p>575.510 MD133671 2x</p> 









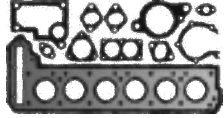
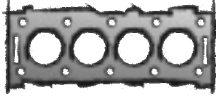

			<p>a) </p> <p>b) </p>	<p>K: </p> <p>N: </p>	
<p>VAS 424.800 FPM 403.730 68001551AA FPM 16x</p>	<p>121.590 68027585AA</p>	<p>121.740 68027586AA →07/2011 305.410 ● 68027586AA →07/2011 </p>	<p>a) 137.771 68027583AA </p> <p>a) 328.572 68027587AA </p> <p>b) 057.370 3/8"x10 b) 108.540 3/8"x10 b) 120.782 04720353 CU A 17x21x1,5</p>	<p>K:← 298.770 AW RD PTFE/ACM 56x70,25x8,2 K:→ 298.670 68024410AB SP LD PTFE/ACM 100 N:← 302.170 05179633AA AW RD PTFE/ACM 38x55x6,2</p>	<p>TLS 302.530 </p>
<p>010.270 ACM 12x</p>			<p>a) 036.164 Dirko HT / EU a) 510.031 Dirko HT / USA/CDN/MEX a) 527.291 Dirko HT / RU a) 648.661 Dirko HT / BR b) 774.460 M 14x1,5x11 b) 394.030 AL C 14x19x2</p>	<p>K:← 034.540 AS RD VMQ 37x50x6 K:→ 902.760 04621939AB A/BS LD FPM 91x111x9 N:← 302.589 A WD FPM 35x50x8 2x</p>	

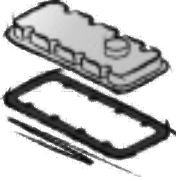













<p>CHRYSLER/ DODGE/JEEP</p>  <p>Das Original</p>				
<p>EXL</p> <p>6 Cyl. 2987 ccm Cyl. 83,0 Ø</p> <p>300 C CRD 09/2005 → 11/2012</p> <p>Commander CRD 09/2005 → 12/2010</p> <p>Grand Cherokee CRD 03/2005 → 10/2011</p>	<p>ES⊕ 542.020 CS* 542.041 incl. 685.340 (FE) CS* 717.570 incl. 686.870 (AL) CS 790.220 OKS 524.281</p> 	<p>475.490 1,20 mm \pm 83,8 Ø L</p>  <p>475.480 1,20 mm \pm 83,8 Ø R</p> 	<p>ZKS 372.940 M 12x1,75x205 2x</p> 	<p>461.682 EL-Liq 74</p>
<p>EXM</p> <p>6 Cyl. 2987 ccm Cyl. 83,0 Ø</p> <p>Sprinter 2500 09/2006 → 12/2009</p> <p>Sprinter 3500 09/2006 → 12/2009</p>	<p>ES⊕ 542.020 CS* 717.570 incl. 686.870 (AL) CS 790.220 OKS 524.281</p> 	<p>475.490 1,20 mm \pm 83,8 Ø L</p>  <p>475.480 1,20 mm \pm 83,8 Ø R</p> 	<p>ZKS 372.940 M 12x1,75x205 2x</p> 	<p>461.682 EL-Liq 74</p>
<p>EXA</p> <p>5 Cyl. 3125 ccm Cyl. 92,0 Ø</p> <p>Grand Cherokee TD 04/1999 → 12/2001</p>		<p>521.339 1,48 mm \pm 5x</p>  <p>521.347 1,59 mm \pm 2 ▽ 5x</p>  <p>521.355 1,69 mm \pm 1 ▽ 5x</p> 		
<p>EGX EGZ</p> <p>6 Cyl. 3199 ccm Cyl. 89,9 Ø</p> <p>Crossfire 07/2003 → 12/2008</p>	<p>ES⊕ 130.360 L ES⊕ 130.370 R CS* 137.130</p>	<p>104.580 05096482AA 0,65 mm \pm 92 Ø L 1 ▽</p>  <p>104.600 05096483AA 0,65 mm \pm 92 Ø R 1 ▽</p> 	<p>ZKS 759.970 05097834AA (8x) M 11x1,5x141 2x</p> 	<p>130.270 05097104AA L</p>  <p>130.280 05097105AA R</p> 

			<p>a) </p> <p>b) </p>	<p>K: </p> <p>N: </p>	
<p>VAS 424.820 FPM 403.730 68001551AA FPM 24x</p>	<p>540.840 2x </p>	<p>540.792 2x </p>	<p>a) 036.164 Dirko HT / EU a) 510.031 Dirko HT / USA/CDN/MEX a) 527.291 Dirko HT / RU a) 648.661 Dirko HT / BR b) 110.604 CU A 12x16x1,5</p>	<p>K:← 424.841 05073675AB ASW RD PTFE/ACM 45x67x8 K:→ 685.340 68006028AA SP LD PTFE/ACM 93 →Mot. 40214378 K:→ 686.870 68006029AA SP LD PTFE/ACM 93 Mot. 40214379→</p>	<p>TLS 309.980 </p>
<p>VAS 424.820 FPM 403.730 68001551AA FPM 24x</p>	<p>540.840 2x </p>	<p>540.792 2x </p>	<p>a) 036.164 Dirko HT / EU a) 510.031 Dirko HT / USA/CDN/MEX a) 527.291 Dirko HT / RU a) 648.661 Dirko HT / BR b) 878.020 M 12x1,5x12 b) 110.604 CU A 12x16x1,5</p>	<p>K:← 424.841 05073675AB ASW RD PTFE/ACM 45x67x8 K:→ 686.870 68006029AA SP LD PTFE/ACM 93</p>	<p>TLS 309.980 </p>
<p>104.380 FPM 10x</p>	<p>435.830 5x </p>	<p>435.810 5x </p>	<p>b) 057.370 3/8"x10 b) 108.540 3/8"x10 b) 120.782 04720353 CU A 17x21x1,5</p>	<p>K:← 501.123 ASW RD ACM 52x68x8 K:→ 298.247 05010817AA ASW LD FPM/ACM 110x130x13</p>	
<p>VAS 712.170 3x 830.489 05080056AA FPM 18x</p>	<p>104.630 05096516AA 6x </p>	<p>104.610 05096513AA 2x </p>	<p>b) 115.100 05073946AA CU A 14x20x1,5</p>	<p>K:← 424.841 05073675AB ASW RD PTFE/ACM 45x67x8 K:→ 524.215 05099347AA ASW LD PTFE/ACM 93x114x11,5</p>	

<p>CHRYSLER/ DODGE/JEEP</p> 				
<p>EG2</p> <p>6 Cyl. 3498 ccm Cyl. 92,9 Ø</p> <p>Sprinter 2500 09/2006 → 12/2008</p> <p>Sprinter 3500 09/2006 → 12/2008</p>	<p>ES⊕ 497.490 CS* 655.540</p>	<p>497.420 ● 68038924AA 0,75 mm $\frac{\pm}{\pm}$ 93,5 Ø L</p>  <p>497.401 0,75 mm $\frac{\pm}{\pm}$ 93,5 Ø R</p> 	<p>ZKS 258.920 M 11x1,5x170 2x</p> 	<p>461.682 EL-Liq 74</p>
<p>ERB</p> <p>6 Cyl. 3604 ccm Cyl. 96,0 Ø</p> <p>200 09/2010 →</p> <p>300 C 09/2010 →</p> <p>Avenger 09/2010 → 12/2014</p> <p>Challenger 09/2010 →</p> <p>Charger 01/2011 →</p> <p>Durango 12/2010 →</p> <p>Grand Caravan 09/2010 →</p> <p>Grand Cherokee 09/2010 →</p> <p>Grand Voyager 02/2011 →</p> <p>Journey 09/2010 →</p> <p>Pacifica 02/2016 →</p> <p>Wrangler 10/2011 →</p>	<p>ES⊕ 694.360 CS 854.010 →08/2012</p> <p>OKS 512.820 68191356AA</p> <p>OKS 854.020 68166067AA →08/2012</p> 	<p>586.270 05184455AH L</p>  <p>586.280 05184456AH R</p> 	<p>ZKS 949.390 06509564AA (8x) M 12x1,5x128 2x</p>	<p>527.780 05184596AE L</p>  <p>527.800 05184595AE R</p> <p>523.950 5184772AB ↑ 2x</p>
<p>EZD</p> <p>8 Cyl. 5654 ccm Cyl. 99,5 Ø</p> <p>300 C 09/2004 →</p> <p>Aspen 04/2008 →</p>	<p>ES⊕ 940.530 68196239AC</p> <p>ES 083.350 300 C LX/LE</p>  <p>CS* 706.870 Aspen (HG)</p>	<p>458.222 53022307AB L</p>  <p>314.350 68240109AA 1,22 mm $\frac{\pm}{\pm}$ 100,6 Ø L</p> <p>458.112 53022306AB R</p>  <p>314.430 68240108AA 1,22 mm $\frac{\pm}{\pm}$ 100,6 Ø R</p>		<p>ZKHS 927.100 5114179AB 2x</p>

			<p>a) </p> <p>b) </p>	<p>K: </p> <p>N: </p>	
<p>VAS 424.820 FPM 403.730 68001551AA FPM 24x</p>	<p>737.250 68021682AA 2x</p> 	<p>479.030 68011721AA L </p> <p>479.040 68011723AA R </p>	<p>a) 036.164 Dirko HT / EU</p> <p>a) 510.031 Dirko HT / USA/CDN/MEX</p> <p>a) 527.291 Dirko HT / RU</p> <p>a) 648.661 Dirko HT / BR</p> <p>b) 877.840 incl. 115.100 M 14x1,5x33</p> <p>b) 115.100 05073946AA CU A 14x20x1,5</p>	<p>K:← 424.841 05073675AB ASW RD PTFE/ACM 45x67x8</p> <p>K:→ 362.691 68013857AA IWD OF LD FPM 93</p>	
<p>VAS 424.820 FPM 403.730 68001551AA FPM 24x</p>	<p>692.760 68093232AA 2x</p> 	<p>524.330 05184331AC 6x↓</p>	<p>a) 036.164 Dirko HT / EU</p> <p>a) 510.031 Dirko HT / USA/CDN/MEX</p> <p>a) 527.291 Dirko HT / RU</p> <p>a) 648.661 Dirko HT / BR</p> <p>b) 298.480 06506214AA M 14x1,5x18</p>	<p>K:← 424.841 05073675AB ASW RD PTFE/ACM 45x67x8</p> <p>K:← 520.690 ● 68079589AA ASW RD FPM 45x67x8,2</p>	
<p>574.190 53022090AB FPM 16x</p>	<p>940.040 53032965AF </p> <p>940.060 53032966AF </p>	<p>907.570 53022143AB 8x</p>	<p>a) 945.730 53021568AE Aspen (HG)</p> <p>a) 945.740 04792874AA 300 C LX/LE</p> <p>b) 298.480 06506214AA M 14x1,5x18</p>	<p>K:← 942.990 53021585AD ASW RD PTFE/ACM 48x76,2x10,3</p> <p>K:→ 488.030 53021338AB AW/BS LD PTFE/ACM 100x120,4x11</p>	

<p>CHRYSLER/ DODGE/JEEP</p> 				
<p>EZD</p> <p>8 Cyl. 5654 ccm Cyl. 99,5 Ø</p> <p>Grand Cherokee 01/2009 → 12/2010</p>	<p>ES 083.350</p>  <p>ES⊕ 940.530 68196239AC</p>	<p>458.222 53022307AB L</p>  <p>314.350 68240109AA 1,22 mm $\frac{+}{-}$ 100,6 Ø L</p> <p>458.112 53022306AB R</p>  <p>314.430 68240108AA 1,22 mm $\frac{+}{-}$ 100,6 Ø R</p>		<p>ZKHS 927.100 5114179AB 2x</p>
<p>EZD</p> <p>8 Cyl. 5654 ccm Cyl. 99,5 Ø</p> <p>Charger 09/2008 → 12/2010</p> <p>Durango 09/2003 → 12/2009</p> <p>RAM 1500 09/2008 → 12/2010</p>	<p>ES 083.350 Charger (LD)</p>  <p>ES⊕ 940.530 68196239AC</p> <p>CS* 706.870 RAM Durango (HB)</p>	<p>458.222 53022307AB L</p>  <p>314.350 68240109AA 1,22 mm $\frac{+}{-}$ 100,6 Ø L</p> <p>458.112 53022306AB R</p>  <p>314.430 68240108AA 1,22 mm $\frac{+}{-}$ 100,6 Ø R</p>		<p>ZKHS 927.100 5114179AB 2x</p>
<p>EZL</p> <p>8 Cyl. 5654 ccm Cyl. 99,5 Ø</p> <p>Wagoneer 01/2022 →</p>	<p>ES⊕ 940.530 68196239AC</p> <p>CS* 706.870</p>	<p>458.222 53022307AB L</p>  <p>458.112 53022306AB R</p> 		<p>ZKHS 927.100 5114179AB 2x</p>

			<p>a) </p> <p>b) </p>	<p>K: </p> <p>N: </p>	
<p>574.190 53022090AB FPM 16x</p>	<p>940.040 53032965AF </p> <p>940.060 53032966AF </p>	<p>907.570 53022143AB 8x</p>	<p>b) 298.480 06506214AA M 14x1,5x18</p>	<p>K:← 942.990 53021585AD ASW RD PTFE/ACM 48x76,2x10,3</p> <p>K:→ 488.030 53021338AB AW/BS LD PTFE/ACM 100x120,4x11</p>	
<p>574.190 53022090AB FPM 16x</p>	<p>940.040 53032965AF </p> <p>940.060 53032966AF </p>	<p>907.570 53022143AB 8x</p>	<p>a) 945.730 53021568AE RAM Durango (HB)</p> <p>a) 945.740 04792874AA Charger (LD)</p> <p>b) 298.480 06506214AA M 14x1,5x18</p>	<p>K:← 942.990 53021585AD ASW RD PTFE/ACM 48x76,2x10,3</p> <p>K:→ 488.030 53021338AB AW/BS LD PTFE/ACM 100x120,4x11</p>	
<p>574.190 53022090AB FPM 16x</p>	<p>940.040 53032965AF </p> <p>940.060 53032966AF </p>	<p>907.570 53022143AB 8x</p>	<p>a) 945.730 53021568AE</p> <p>b) 298.480 06506214AA M 14x1,5x18</p>	<p>K:← 942.990 53021585AD ASW RD PTFE/ACM 48x76,2x10,3</p> <p>K:→ 488.030 53021338AB AW/BS LD PTFE/ACM 100x120,4x11</p>	

CITROËN



CITROËN	ccm	kW	→	→			
AX	4	954	33	07/1986	12/1998	CDY (TU9M)	684
AX	4	954	32	09/1986	06/1992	C1A	684
AX	4	954	30	12/1986	12/1988	C3A	684
AX	4	954	37	02/1987	12/1998	CDZ (TU9M)	684
AX	4	1124	44	09/1986	12/1997	H1B HDZ (TU1M)	686
AX	4	1124	40	12/1986	04/1994	H1A H1B HAZ (TU1CP)	686
AX	4	1294	70	04/1987	12/1988	M4A	692
AX	4	1360	62	09/1986	12/1992	K2A K2B	692
AX	4	1360	44	12/1986	12/1988	KAY (TU3CP)	692
AX	4	1360	55	04/1987	04/1997	KDX (TU3M/Z) KDY (TU3FM) KDY (TU3M) KDZ (TU3M/Z)	692 694
AX	4	1360	61	01/1988	12/1992	K2A	692
AX	4	1360	49	06/1988	12/1989	K1F	692
AX	4	1360	38	09/1988	06/1992	K9A (TUD3)	692
AX	4	1360	51	01/1989	12/1991	K1G	692
AX	4	1360	59	01/1989	12/1991	KDZ (TU3M/Z)	692
AX	4	1360	39	06/1991	07/1992	K9A (TUD3)	692
AX	4	1360	69	06/1991	12/1996	KFZ (TU3FJ2/Z)	696
AX	4	1360	74	06/1991	12/1992	KFZ (TU3FJ2/Z)	696
AX	4	1360	37	08/1991	12/1997	K9Y (TUD3Y)	692
AX	4	1360	66	08/1991	12/1996	KFY (TU3FJ2)	696
AX	4	1360	48	08/1992	04/1994	K1F	692
AX	4	1527	40	08/1994	12/1997	VJY (TUD5)	704
AX	4	1527	43	08/1994	12/1997	VJY (TUD5) VJZ (TUD5)	704
Berlingo	4	1124	44	07/1996	05/2008	HDZ (TU1M) HFX (TU1JP)	686
Berlingo	3	1199	81	02/2016		HNP (EB2ADT) HNZ (EB2DT)	688 690
Berlingo	3	1199	96	07/2019		HNS (EB2ADTS)	688
Berlingo	4	1360	55	07/1996		KFW (TU3A) KFW (TU3JP) KFX (TU3A) KFX (TU3JP)	696
Berlingo	4	1360	57	08/1999	05/2008	KFW (TU3JP) KFX (TU3JP)	696
Berlingo	4	1360	48	11/2002	12/2011	KFW (TU3JP)	696

CITROËN	ccm	kW	→	→			
Berlingo	4	1360	53	11/2002	10/2005	KFW (TU3JP)	696
Berlingo	4	1587	80	10/2000		NFU (TU5JP4)	716
Berlingo	4	1587	81	11/2002		NFU (TU5JP4)	716
Berlingo	4	1587	66	04/2008		NFR (TU5JP4B)	716
Berlingo	4	1587	90	10/2018		NFP (EC5)	714
Berlingo	4	1598	88	11/2009		5FS (EP6C)	722
Berlingo	4	1598	72	07/2010		5FK (EP6CB)	722
Berlingo	4	1761	66	04/1997	10/2002	LFX (XU7JB)	726
Berlingo	4	1761	58	07/2003	04/2004	LFX (XU7JB)	726
Berlingo D	4	1769	43	07/1996	10/2002	A9A (XUD7)	730
Berlingo D	4	1769	44	11/1996	10/1999	A9A (XUD7)	730
Berlingo D	4	1868	51	07/1998	12/2011	WJY (DW8B) WJZ (DW8)	732
Berlingo D	4	1905	50	07/1996	12/2003	D9B (XUD9A/L) DJY (XUD9A)	736
Berlingo D	4	1905	51	07/1996	12/2003	DJY (XUD9A)	736
Berlingo HDI	4	1499	56	06/2018		YHW (DV5RE)	704
Berlingo HDI	4	1499	75	06/2018		YHY (DV5RD)	704
Berlingo HDI	4	1499	96	06/2018		YHZ (DV5RC)	702
Berlingo HDI	4	1499	55	10/2019		YHW (DV5RE)	704
Berlingo HDI	4	1560	55	07/2005		9HN (DV6ETED) 9HT (DV6BTED4) 9HT (DV6BUTED4) 9HW (DV6BTED4) BHW (DV6FE) DV6B	706 710 712
Berlingo HDI	4	1560	66	07/2005		9HE (DV6DBM) 9HF (DV6DTE) 9HS (DV6TED4BU) 9HV (DV6TED4B) 9HX (DV6ATED4) 9HX (DV6AUTED4)	706 710
Berlingo HDI	4	1560	80	04/2008		9HZ (DV6TED4)	710
Berlingo HDI	4	1560	68	11/2009		9HJ (DV6DTEDM) 9HP (DV6DTE)	706 708
Berlingo HDI	4	1560	82	07/2010		9HL (DV6C) 9HR (DV6C)	706 708
Berlingo HDI	4	1560	84	07/2010		9HL (DV6C) 9HR (DV6C) DV6CTED	706 708
Berlingo HDI	4	1560	73	12/2014		BHY (DV6FD)	712



CITROËN



CITROËN	ccm	kW	→	→		
Berlingo HDI	4	1560	88	12/2014	BHZ (DV6FC)	712
Berlingo HDI	4	1997	66	12/1999	12/2011 RHY (DW10TD)	756
BX	4	1124	42	10/1986	06/1992	H1A 686
BX	4	1124	40	10/1988	06/1992	HDZ (TU1M) 686
BX	4	1360	40	10/1982	01/1992	KAZ 692
BX	4	1360	52	04/1983	07/1989	K1G 692
BX	4	1360	44	01/1987	01/1992	K1F 692
BX	4	1360	47	01/1989	12/1989	K1H (TU3A) 692
BX	4	1360	55	01/1989	02/1993	KDY (TU3M) 692 KDZ (TU3M/Z)
BX	4	1580	66	10/1982	06/1988	171A 712 171B 171C
BX	4	1580	68	10/1982	12/1992	171C 712 XU52C
BX	4	1580	64	07/1985	12/1994	171D 712
BX	4	1580	76	03/1986	12/1994	180Z 712
BX	4	1580	53	01/1987	12/1994	B1E (XU51C) 712
BX	4	1580	58	01/1987	02/1993	B1A (XU51C/K) 712 B1E (XU51C)
BX	4	1580	85	01/1987	01/1992	B6D 712 B6E
BX	4	1580	59	10/1987	05/1992	B1E (XU51C) 712
BX	4	1580	55	09/1988	12/1994	BAY (XU5CP) 712 BAZ (XU5CP)
BX	4	1580	65	05/1989	12/1994	BDY (XU5M) 712 BDZ (XU5M)
BX	4	1580	70	02/1992	06/1994	171B 712 182A
BX	4	1769	44	10/1985	09/1993	161 (XUD7) 728 161A (XUD7)
BX	4	1769	66	03/1988	12/1994	A8A (XUD7TE) 728 AJZ (XUD7TE)
BX	4	1905	47	09/1983	11/1994	162 (XUD9) 734 D9A (XUD9) 736 DJZ (XUD9A)
BX	4	1905	78	09/1984	01/1992	D2E 734
BX	4	1905	90	10/1984	06/1994	D6A (XU9J2) 734
BX	4	1905	92	10/1985	12/1994	D6A (XU9J2) 734 D6U
BX	4	1905	75	07/1986	12/1994	159A 734 D2A (XU92C) DFZ (XU9J1)
BX	4	1905	77	07/1986	05/1989	D2A (XU92C) 734
BX	4	1905	70	09/1986	12/1989	D2C (XU92C) 734

CITROËN	ccm	kW	→	→		
BX	4	1905	52	01/1987	01/1992	D9B 736 D9B (XUD9A/L)
BX	4	1905	76	01/1987	01/1992	D2A (XU92C) 734
BX	4	1905	51	03/1987	12/1994	D9B (XUD9A/U) 736
BX	4	1905	116	09/1987	12/1988	D6C (XU9J4) 734
BX	4	1905	108	03/1988	02/1993	DFW (XU9J4) 734
BX	4	1905	80	06/1988	12/1994	D2F 734 DDZ (XU9M)
BX	4	1905	88	06/1988	12/1994	DKZ (XU9JA) 734
BX	4	1905	117	01/1990	01/1992	D6C 734
BX	4	1905	118	01/1992	12/1993	D6C (XU9J4) 734
BX	4	1905	107	02/1992	12/1994	159K 734
BX	4	1905	53	03/1992	10/1993	D9B (XUD9A/U) 736
C1	3	998	50	06/2005	09/2014	CFA (384F) 684 CFB (1KR)
C1	3	998	51	04/2014		CFB (1KR) 684
C1	3	998	53	06/2018		CFB (1KR) 684
C1	3	1199	60	04/2014		HMT (EB2D) 688 HMZ (EB2) HMZ (EB2F)
C 15	4	954	33	10/1984	12/1997	C1A (TU9/K) 684 C1B (TU9/W) TU9
C 15	4	954	37	11/1992	07/1996	TU9K 684
C 15	4	1124	44	07/1988	12/1996	HDZ (TU1M) 686
C 15	4	1124	40	10/1988	07/1996	H1A 686 HDZ (TU1M)
C 15	4	1360	49	05/1987	12/1996	K1H (TU3A) 692 KAZ
C 15	4	1360	40	07/1987	12/1996	K3A 692
C 15	4	1360	55	05/1991	12/1996	KDY (TU3FM) 692 KDY (TU3M) 694
C 15	4	1769	44	07/1986	12/2000	161A (XUD7) 728
C 15	4	1868	51	01/2000	07/2005	WJY (DW8B) 732
C 15	4	1868	44	12/2000	12/2005	WJX (DW8B) 732
C1 HDI	4	1398	40	06/2005	09/2014	8HT (DV4TD) 700
C2	4	1124	44	09/2003	09/2012	HFX (TU1A) 686 HFX (TU1JP)
C2	4	1360	54	09/2003	12/2009	KFV (TU3A) 694 KFV (TU3JP) 696
C2	4	1360	65	04/2005	12/2009	KFU (ET3J4) 694
C2	4	1360	55	10/2006	12/2009	KFV (TU3JP) 694
C2	4	1587	80	07/2003	10/2010	NFU (TU5JP4) 716

CITROËN

CITROËN



CITROËN	ccm	kW	→	→	→	→	→
C2	4	1587	90	10/2004	12/2009	NFS (TU5JP4S)	716
C2	4	1587	81	01/2008	09/2017	NFU (TU5JP4)	716
C 25	4	1905	51	07/1987	02/1994	D9B (XUD9A/U) DJY (XUD9A)	736
C2 HDI	4	1398	50	07/2003	12/2009	8HX (DV4TD) 8HZ (DV4TD)	700
C2 HDI	4	1398	51	09/2003	04/2005	8HX (DV4TD) 8HZ (DV4TD)	700
C2 HDI	4	1560	80	09/2005	12/2009	9HZ (DV6TED4)	710
C3	3	999	50	08/2012		ZMZ (EB0)	684
C3	4	1124	44	02/2002		HFV (TU1A) HFX (TU1A) HFX (TU1JP)	686
C3	3	1199	60	06/2012		HMZ (EB2) HMZ (EB2F)	688
C3	3	1199	81	10/2014		HNP (EB2ADT) HNV (EB2DTM) HNZ (EB2DT)	688 690 690
C3	3	1199	50	07/2016		HMM (EB2FAD) HMP (EB2FB)	688
C3	3	1199	66	10/2016		HMZ (EB2F)	688
C3	3	1199	61	05/2018		HMR (EB2FA)	688
C3	4	1360	54	02/2002		KFT (TU3A) KFT (TU3AE5) KFV (TU3A) KFV (TU3JP)	694 696 696 696
C3	4	1360	65	12/2003		KFU (ET3J4)	694
C3	4	1360	58	12/2005	07/2012	KFV (TU3A)	696
C3	4	1360	59	12/2005	07/2012	KFV (TU3JP)	694
C3	4	1397	70	11/2009		8FN (EP3) 8FP (EP3C)	698
C3	4	1397	72	11/2009		8FR (EP3)	698
C3	4	1587	80	02/2002	08/2010	NFU (TU5JP4)	716
C3	4	1587	81	05/2003	09/2005	NFU (TU5JP4)	716
C3	4	1587	83	06/2005	12/2013	NFU (TU5JP4)	716
C3	4	1587	90	01/2012	09/2016	EC5	714
C3	4	1587	87	10/2016		EC5 NFU (TU5JP4)	714 716
C3	4	1587	85	02/2017		NFP (EC5)	714
C3	4	1598	88	11/2009		5FS (EP6C)	722
C3 Aircross	3	1199	60	06/2017		HMR (EB2FA) HMZ (EB2F)	688
C3 Aircross	3	1199	81	06/2017		HNP (EB2ADT) HNV (EB2DTM) HNZ (EB2DT)	688 690 690

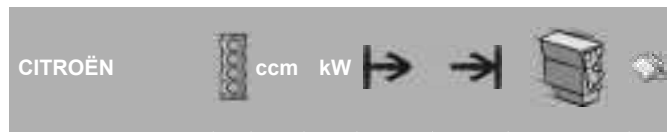

C3 Aircross	3	1199	96	07/2017		HNS (EB2ADTS) HNY (EB2DTS)	688 690
C3 Aircross	4	1587	81	08/2010		NFU (TU5JP4)	716
C3 Aircross	4	1587	90	07/2012		EC5 NFU (TU5JP4)	714 716
C3 Aircross	4	1587	85	06/2013		NFU (TU5JP4)	716
C3 Aircross	4	1587	83	12/2014		NFU (TU5JP4)	716
C3 Aircross HDI	4	1499	73	08/2018		YHY (DV5RD)	704
C3 Aircross HDI	4	1499	75	08/2018		YHY (DV5RD)	704
C3 Aircross HDI	4	1499	88	08/2018		YHX (DV5RC)	702
C3 Aircross HDI	4	1499	81	10/2020		YHS (DV5RCE)	702
C3 Aircross HDI	4	1560	85	06/2017		BHX (DV6FC)	712
C3 Aircross HDI	4	1560	73	07/2017		BHY (DV6FD)	712
C3 Aircross HDI	4	1560	88	07/2017		BHZ (DV6FC)	712
C3 Aircross HDI	4	1560	68	10/2017		9HP (DV6D) 9HP (DV6DTED)	708
C3 HDI	4	1398	50	02/2002		8HR (DV4C) 8HX (DV4TD) 8HZ (DV4TD)	698 700 700
C3 HDI	4	1398	66	02/2002		8HY (DV4TED4)	702
C3 HDI	4	1398	52	07/2003	02/2011	8HZ (DV4TD)	700
C3 HDI	4	1398	55	05/2005		8HX (DV4TD)	700
C3 HDI	4	1499	75	05/2018		YHY (DV5RD)	704
C3 HDI	4	1560	80	09/2005		9HZ (DV6TED4)	710
C3 HDI	4	1560	66	10/2005		9HJ (DV6DM) 9HX (DV6ATED4)	706 710
C3 HDI	4	1560	68	11/2009		9HJ (DV6DTEDM) 9HP (DV6DTED)	706 708
C3 HDI	4	1560	82	11/2009		9HR (DV6C)	708
C3 HDI	4	1560	84	09/2012		9HD (DV6C)	706
C3 HDI	4	1560	73	07/2014		BHY (DV6FD)	712
C3 HDI	4	1560	55	03/2015		9HK (DV6ETEDM) BHW (DV6FE)	706 712
C3 Picasso	3	1199	81	01/2015		HNZ (EB2DT)	690
C3 Picasso	4	1397	70	02/2009		8FN (EP3) 8FP (EP3C) 8FS (EP3)	698
C3 Picasso	4	1587	81	04/2011	06/2013	NFU (TU5JP4) NFX (TU5JP4)	716 718
C3 Picasso	4	1587	83	05/2011	06/2012	NFX (TU5JP4)	718



CITROËN



CITROËN	ccm	kW	→	→			
C3 Picasso	4	1587	85	06/2013		NFP (EC5)	714
C3 Picasso	4	1590	90	07/2011	12/2016	EC5 NFU (TU5JP4)	714 716
C3 Picasso	4	1598	88	02/2009		5FS (EP6C) 5FW (EP6)	722
C3 Picasso	4	1598	84	07/2009		5FP (EP6)	722
C3 Picasso HDI	4	1560	66	02/2009		9HX (DV6ATED4)	710
C3 Picasso HDI	4	1560	80	02/2009		9HZ (DV6TED4)	710
C3 Picasso HDI	4	1560	82	05/2010		9HR (DV6C)	708
C3 Picasso HDI	4	1560	68	07/2010		9HP (DV6DTE)	708
C3 Picasso HDI	4	1560	84	01/2013		9HD (DV6C)	706
C3 Picasso HDI	4	1560	73	01/2015		BHY (DV6FD)	712
C3 Pluriel	4	1360	54	05/2003		KFV (TU3A) KFV (TU3JP)	694 696
C3 Pluriel	4	1360	55	07/2003		KFV (TU3A)	696
C3 Pluriel	4	1587	80	05/2003		NFU (TU5JP4)	716
C3 Pluriel HDI	4	1398	50	04/2004		8HX (DV4TD)	700
C4	3	1199	96	04/2014		HNS (EB2ADTS) HNY (EB2DTS)	688 690
C4	3	1199	81	02/2015	12/2017	HNV (EB2DTM) HNZ (EB2DT)	690
C4	3	1199	114	01/2021		HNJ (EB2ADTXM) HNN (EB2ADTX)	688
C4	3	1199	75	04/2021		HNE (EB2ADTD) HNK (EB2ADTD)	688
C4	4	1360	65	11/2004	07/2011	KFU (ET3J4)	694
C4	4	1397	70	11/2009		8FP (EP3C)	698
C4	4	1587	80	11/2004	07/2011	NFU (TU5JP4)	716
C4	4	1587	83	09/2007	12/2015	N6A (TU5JP4)	716
C4	4	1587	81	03/2011		NFU (TU5JP4)	716
C4	4	1587	85	01/2013		NFP (EC5)	714
C4	4	1598	103	06/2008	07/2011	5FT (EP6DT)	720
C4	4	1598	88	07/2008		5FS (EP6C) 5FW (EP6)	722
C4	4	1598	110	07/2008		5FE (EP6CDTMD) 5FX (EP6DT)	720
C4	4	1598	115	11/2009	12/2016	5FV (EP6CDT)	720

CITROËN	ccm	kW	→	→			
C4	4	1598	121	08/2013		5FM (EP6CDTM) 5GY (EP6FDTM)	720 724
C4	4	1598	127	12/2014	03/2021	5FM (EP6CDTM) 5GY (EP6FDTM)	720 724
C4	4	1997	100	11/2004	07/2007	RFN (EW10J4)	746
C4	4	1997	103	11/2004	07/2011	RFJ (EW10A)	744
C4	4	1997	130	11/2004	12/2010	RFK (EW10J4S)	746
C4	4	1997	111	07/2006	12/2016	RFJ (EW10A)	744
C4	4	1997	105	09/2006		RFJ (EW10A)	744
C4	4	1997	101	01/2007	11/2014	RFN (EW10J4)	746
C4	4	1997	109	10/2008	07/2013	RFJ (EW10A)	744
C4 Aircross	4	1587	83	08/2010	06/2012	NFX (TU5JP4)	718
C4 Aircross	4	1587	87	06/2017	03/2021	EC5	714
C4 Aircross	4	1590	86	04/2012		4A92 NKZ (4A92)	720
C4 Aircross	4	1590	90	07/2012	03/2021	NFU (TU5JP4)	716
C4 Aircross	4	1998	110	04/2012		4B11	762
C4 Aircross HDI	4	1560	84	04/2012		9HD (DV6C) 9HL (DV6C)	706
C4 Aircross HDI	4	1798	103	04/2012		4N13	730
C4 Aircross HDI	4	1798	110	04/2012		4N13	730
C4 Cactus	3	1199	55	09/2014		HMU (EB2D) HMU (EB2FD)	688
C4 Cactus	3	1199	60	09/2014		HMZ (EB2) HMZ (EB2F)	688
C4 Cactus	3	1199	81	09/2014		HNP (EB2ADT) HNH (EB2DTM) HNZ (EB2DT)	688 690
C4 Cactus	3	1199	96	11/2017		HNS (EB2ADTS) HNY (EB2DTS)	688 690
C4 Cactus	4	1587	85	01/2019		EC5	714
C4 Cactus	4	1587	87	01/2019		EC5	714
C4 Cactus	4	1587	90	01/2019		EC5	714
C4 Cactus	4	1598	121	01/2019		5GY (EP6FDTM)	724
C4 Cactus	4	1598	127	01/2019		5GY (EP6FDTM)	724
C4 Cactus HDI	4	1499	73	06/2018		YHY (DV5RD)	704
C4 Cactus HDI	4	1499	75	06/2018		YHY (DV5RD)	704
C4 Cactus HDI	4	1499	88	09/2018		YHX (DV5RC)	702

CITROËN

CITROËN



CITROËN	ccm	kW	→	→	→	→
C4 Cactus HDI	4	1560	68	09/2014		9HJ (DV6DTE) 706 9HP (DV6D) 708 9HP (DV6DTE)
C4 Cactus HDI	4	1560	73	09/2014		BHY (DV6FD) 712
C4 HDI	4	1499	96	10/2020		YHZ (DV5RC) 702
C4 HDI	4	1499	81	12/2020		YHS (DV5RCE) 702
C4 HDI	4	1560	66	11/2004	07/2011	9HV (DV6TED4B) 710 9HV (DV6TED4BU) 710 9HX (DV6ATED4)
C4 HDI	4	1560	80	11/2004	11/2012	9HG (DV6C M) 706 9HY (DV6TED4) 710 9HZ (DV6TED4)
C4 HDI	4	1560	85	07/2006		9HY (DV6TED4) 710 BHX (DV6FC) 712
C4 HDI	4	1560	68	11/2009		9HJ (DV6DTE) 706 9HP (DV6DTE)
C4 HDI	4	1560	82	11/2009		9HR (DV6C) 708
C4 HDI	4	1560	84	04/2010		9HD (DV6C) 706 9HG (DV6C M) 708 9HR (DV6C)
C4 HDI	4	1560	73	07/2014		BHY (DV6FD) 712
C4 HDI	4	1560	88	02/2015		BHZ (DV6FC) 712
C4 HDI	4	1997	100	11/2004	07/2011	RHR (DW10BTE) 748
C4 HDI	4	1997	81	04/2007	12/2011	RHZ (DW10ATE) 758
C4 HDI	4	1997	103	06/2007	07/2011	RHF (DW10BTE) 748
C4 HDI	4	1997	110	11/2009		AHR (DW10FD) 744 RHE (DW10CTE) 746
C4 HDI	4	1997	120	10/2010		RHH (DW10CTE) 746
C4 Picasso	3	1199	96	04/2014		HNY (EB2DTS) 690
C4 Picasso	3	1199	81	04/2016		HNZ (EB2DT) 690
C4 Picasso	4	1598	88	07/2008		5FS (EP6C) 722 5FW (EP6)
C4 Picasso	4	1598	103	07/2008	08/2013	5FT (EP6DT) 720
C4 Picasso	4	1598	110	07/2008		5FX (EP6DT) 720
C4 Picasso	4	1598	115	09/2010		5FV (EP6CDT) 720
C4 Picasso	4	1598	121	07/2014		5GZ (EP6FDT) 724
C4 Picasso	4	1749	92	10/2006	10/2012	6FY (EW7A) 724
C4 Picasso	4	1749	86	06/2009	01/2013	6FY (EW7A) 724

CITROËN	ccm	kW	→	→	→	→
C4 Picasso	4	1997	103	10/2006	08/2013	RFJ (EW10A) 744
C4 Picasso	4	1997	105	05/2008	08/2013	RFJ (EW10A) 744 RFN (EW10J4) 746
C4 Picasso HDI	4	1560	80	10/2006	08/2013	9HY (DV6TED4) 710 9HZ (DV6TED4)
C4 Picasso HDI	4	1560	82	09/2010	08/2013	9HL (DV6C) 706 9HR (DV6C) 708
C4 Picasso HDI	4	1560	68	02/2013		9HP (DV6DTE) 708
C4 Picasso HDI	4	1560	85	02/2013		9HC (DV6C) 706 BHX (DV6FC) 712
C4 Picasso HDI	4	1560	88	07/2014		BHZ (DV6FC) 712
C4 Picasso HDI	4	1560	73	12/2014		BHY (DV6FD) 712
C4 Picasso HDI	4	1997	100	10/2006		AHV (DW10FD) 744 RHD (DW10CB) 746 RHJ (DW10BTE) 748 RHR (DW10BTE)
C4 Picasso HDI	4	1997	110	07/2009		AHE (DW10FD) 744 AHR (DW10FD) 746 AHX (DW10FD) 746 RHE (DW10CTE)
C4 Picasso HDI	4	1997	120	09/2010	08/2013	RHH (DW10CTE) 746
C4 Spacetourer	3	1199	81	04/2018		HNY (EB2DTS) 690
C4 Spacetourer	3	1199	96	04/2018		HNY (EB2DTS) 690
C4 Spacetourer	4	1598	121	04/2018		5GZ (EP6FDT) 724
C4 Spacetourer HDI	4	1499	96	05/2018		YHZ (DV5RC) 702
C4 Spacetourer HDI	4	1560	73	04/2018		BHY (DV6FD) 712
C4 Spacetourer HDI	4	1560	85	04/2018		9HC (DV6C) 706
C4 Spacetourer HDI	4	1560	88	04/2018		BHZ (DV6FC) 712
C4 Spacetourer HDI	4	1997	110	04/2018		AHX (DW10FD) 744
C4 Spacetourer HDI	4	1997	120	04/2018		EHY (DW10FCC) 744
C5	3	1199	96	09/2021		HNS (EB2ADTS) 688
C5	4	1598	110	04/2009		5FN (EP6CDT) 720
C5	4	1598	115	04/2009		5FV (EP6CDT) 720
C5	4	1598	88	07/2010		5FS (EP6C) 722
C5	4	1598	120	03/2011		5FM (EP6DT) 720
C5	4	1749	85	03/2001		6FZ (EW7J4) 724
C5	4	1749	92	09/2005		6FY (EW7A) 724
C5	4	1997	100	03/2001	08/2004	RFN (EW10J4) 746



CITROËN	ccm	kW	→	→		
C5	4	1997	103	03/2001		RFJ (EW10A) 744 RLZ (EW10D) 760
C5	4	1997	105	03/2005	11/2007	RFJ (EW10A) 744
C5	6	2946	152	03/2001		XFU (ES9A) 784 XFX (ES9J4S) 786
C5	6	2946	157	05/2001	08/2004	XFX (ES9J4S) 784
C5	6	2946	173	08/2001		ES9J4SHP 784 XFX (ES9J4S)
C5	6	2946	154	08/2002	03/2005	XFX (ES9J4S) 784
C5	6	2946	155	10/2004		XFU (ES9A) 786 XFX (ES9A)
C5 Aircross	3	1199	96	11/2018		HNS (EB2ADTS) 688
C5 Aircross	4	1598	133	11/2018		5GF (EP6FADTXD) 722
C5 Aircross	4	1598	121	05/2019		5GY (EP6FDTM) 724
C5 Aircross	4	1598	110	09/2019		5GX (EP6FDTMD) 724
C5 Aircross HDI	4	1499	96	11/2018		YHZ (DV5RC) 702
C5 Aircross HDI	4	1997	130	11/2018		EHZ (DW10FC) 744
C5 HDI	4	1560	80	09/2004		9HY (DV6TED4) 710 9HZ (DV6TED4)
C5 HDI	4	1560	82	07/2010		9HL (DV6C) 706 9HR (DV6C) 708
C5 HDI	4	1560	84	01/2012		9HL (DV6C) 706 9HR (DV6C) 708
C5 HDI	4	1997	66	03/2001	08/2004	RHY (DW10TD) 756
C5 HDI	4	1997	79	03/2001	08/2004	RHS (DW10ATED) 756 RHZ (DW10ATED) 758
C5 HDI	4	1997	80	03/2001	08/2004	RHZ (DW10ATED) 758
C5 HDI	4	1997	100	09/2004		RHD (DW10CTED4) 746 RHF (DW10BTED4) 748 RHR (DW10BTED4)
C5 HDI	4	1997	103	11/2008		RHA (DW10CTED4) 746 RHF (DW10BTED4) 748
C5 HDI	4	1997	110	04/2009		AHR (DW10FD) 744 RHE (DW10CTED4) 746
C5 HDI	4	1997	120	04/2009		RHH (DW10CTED4) 746

CITROËN	ccm	kW	→	→		
C5 HDI	4	1997	101	10/2014		RHR (DW10BTED4) 748
C5 HDI	4	1997	133	03/2015		AHW (DW10FC) 744
C5 HDI	4	2179	98	03/2001		4HX (DW12TED4) 774
C5 HDI	4	2179	125	04/2006		4HT (DW12BTED4) 772
C5 HDI	4	2179	120	05/2006		4HP (DW12BTED4) 772 4HR (DW12BTED4)
C5 HDI	4	2179	150	07/2010		4HL (DW12C) 770
C5 HDI	6	2720	150	02/2008		DT17ED4 780 UHZ (DT17TED4)
C5 HDI	6	2992	177	04/2009	10/2014	DT20C 786
C6	6	2946	155	09/2005	12/2012	XFV (ES9A) 784 XFX (ES9J4S) 786
C6 HDI	4	2179	120	06/2006	12/2010	4HP (DW12BTED4) 772
C6 HDI	4	2179	125	06/2006	12/2012	4HT (DW12BTED4) 772
C6 HDI	6	2720	150	09/2005	12/2011	DT17ED4 780 UHZ (DT17TED4)
C6 HDI	6	2992	177	04/2009	12/2012	DT20C 786
C6 HDI	6	2993	155	06/2009	12/2010	DT20C 786
C8	4	1997	100	07/2002		RFN (EW10J4) 746
C8	4	1997	103	06/2004		RFJ (EW10A) 744
C8	4	2230	116	07/2002		3FZ (EW12J4) 778
C8	6	2946	150	07/2002		XFX (ES9J4S) 784
C8 HDI	4	1997	79	07/2002		RHM (DW10ATED4) 752 RHT (DW10ATED4)
C8 HDI	4	1997	80	07/2002		RHW (DW10ATED4) 752
C8 HDI	4	1997	81	07/2002		RHT (DW10ATED4) 752
C8 HDI	4	1997	100	03/2006		RHD (DW10CB) 746 RHD (DW10CTED4) 748 RHR (DW10BTED4)
C8 HDI	4	1997	120	03/2006		RHH (DW10CTED4) 746
C8 HDI	4	1997	88	07/2006		RHK (DW10UTED4) 748

CITROËN

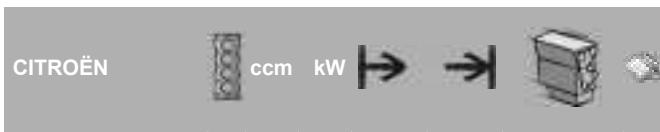

C8 HDI	4	2179	94	07/2002		4HW (DW12TED4)	772
C8 HDI	4	2179	125	06/2006	12/2012	4HS (DW12BTED4) 4HT (DW12BTED4)	772
C8 HDI	4	2179	120	06/2007		4HP (DW12BTED4) 4HR (DW12BTED4)	772
C-Crosser	4	1998	108	11/2010		4B11	762
C-Crosser	4	2360	125	08/2008		4B12 SFZ (4B12 MMC)	778
C-Crosser HDI	4	2179	115	02/2007		4HK (DW12ME5) 4HN (DW12MTED4)	772
C-Elysee	3	1199	53	11/2012		HMY (EB2M)	688
C-Elysee	3	1199	60	12/2014		HMZ (EB2) HMZ (EB2F)	688
C-Elysee	3	1199	61	02/2018		HMR (EB2FA)	688
C-Elysee	4	1587	85	11/2012		NFP (EC5)	714
C-Elysee HDI	4	1499	75	05/2018		YHY (DV5RD)	704
C-Elysee HDI	4	1560	68	11/2012		9HJ (DV6DTEDEM) 9HP (DV6DTEDEM)	706 708
C-Elysee HDI	4	1560	73	11/2014		BHY (DV6FD)	712
DS 3	3	1199	60	01/2013	07/2015	HMZ (EB2) HMZ (EB2F)	688
DS 3	3	1199	81	10/2014	07/2015	HNZ (EB2DT)	690
DS 3	4	1397	72	11/2009	07/2015	8FR (EP3) 8FR (EP3C)	698
DS 3	4	1397	70	04/2010	07/2015	8FN (EP3) 8FP (EP3C) 8FR (EP3C)	698
DS 3	4	1598	110	01/2010	07/2015	5FN (EP6CDT) 5FX (EP6DT)	720
DS 3	4	1598	88	04/2010	07/2015	5FS (EP6C)	722
DS 3	4	1598	115	04/2010	07/2015	5FR (EP6DT) 5FV (EP6CDT)	720
DS 3	4	1598	149	02/2011	07/2015	5FF (EP6DTS)	720
DS 3	4	1598	152	02/2011	07/2015	5FD (EP6DTS)	720
DS 3	4	1598	120	01/2012	07/2015	5FM (EP6DT)	720
DS 3	4	1598	121	10/2014	07/2015	5GZ (EP6FDT)	724
DS 3 HDI	4	1398	50	04/2010	07/2015	8HP (DV4C) 8HR (DV4C)	698
DS 3 HDI	4	1560	68	11/2009	07/2015	9HP (DV6DTEDEM)	708



DS 3 HDI	4	1560	82	11/2009	07/2015	9HR (DV6C)	708
DS 3 HDI	4	1560	84	08/2012	07/2015	9HD (DV6C) 9HL (DV6C)	706
DS 3 HDI	4	1560	85	10/2013	07/2015	BHX (DV6FC)	712
DS 3 HDI	4	1560	88	10/2013	07/2015	BHZ (DV6FC)	712
DS 3 HDI	4	1560	73	07/2014	07/2015	BHY (DV6FD)	712
DS 3 HDI	4	1560	75	07/2014	07/2015	BHY (DV6FD)	712
DS 3 HDI	4	1560	55	03/2015	07/2015	BHW (DV6FE)	712
DS 4	3	1199	96	07/2014	07/2015	HNY (EB2DTS)	690
DS 4	4	1598	88	04/2011	07/2015	5FS (EP6C)	722
DS 4	4	1598	110	04/2011	07/2015	5FE (EP6CDTMD)	720
DS 4	4	1598	115	04/2011	07/2015	5FV (EP6CDT)	720
DS 4	4	1598	147	04/2011	07/2015	5FU (EP6DTX)	722
DS 4	4	1598	121	01/2012	07/2015	5FM (EP6CDTM) 5GZ (EP6FDT)	720 724
DS 4	4	1598	120	04/2012	07/2015	5FM (EP6CDTM)	720
DS 4 HDI	4	1560	82	04/2011	07/2015	9HR (DV6C)	708
DS 4 HDI	4	1560	68	05/2011	07/2015	9HP (DV6DTEDEM)	708
DS 4 HDI	4	1560	84	08/2012	07/2015	9HD (DV6C) 9HL (DV6C)	706
DS 4 HDI	4	1560	85	07/2014	07/2015	BHX (DV6FC)	712
DS 4 HDI	4	1560	88	07/2014	07/2015	BHZ (DV6FC)	712
DS 4 HDI	4	1997	120	04/2011	07/2015	RHH (DW10CTED4)	746
DS 4 HDI	4	1997	100	09/2011	07/2015	AHS (DW10FD) AHV (DW10FD) RHD (DW10CB) RHD (DW10CTED4)	744 746
DS 4 HDI	4	1997	110	07/2014	07/2015	AHX (DW10FD)	744
DS 4 HDI	4	1997	133	07/2014	07/2015	AHV (DW10FC)	744
DS 5	4	1598	110	11/2011	07/2015	5FE (EP6CDTMD)	720
DS 5	4	1598	115	11/2011	07/2015	5FV (EP6CDT)	720
DS 5	4	1598	147	11/2011	07/2015	5FU (EP6DTX)	722
DS 5	4	1598	121	01/2012	07/2015	5FM (EP6CDTM) 5FM (EP6DT) 5GZ (EP6FDT)	720 724
DS 5 HDI	4	1560	82	11/2011	07/2015	9HR (DV6C)	708
DS 5 HDI	4	1560	84	06/2012	07/2015	9HD (DV6C)	706



CITROËN



CITROËN	ccm	kW	→	→			
DS 5 HDI	4	1560	85	11/2013	07/2015	BHX (DV6FC)	712
DS 5 HDI	4	1560	88	07/2014	07/2015	BHZ (DV6FC)	712
DS 5 HDI	4	1997	100	11/2011	07/2015	RHD (DW10CB)	746
DS 5 HDI	4	1997	120	11/2011	07/2015	RHC (DW10CTED4) RHH (DW10CTED4)	746
DS 5 HDI	4	1997	133	08/2013	07/2015	AHW (DW10FC)	744
DS 5 HDI	4	1997	110	07/2014	07/2015	AHX (DW10FD)	744
Evasion	4	1761	76	02/1996	12/1996	LFZ (XU7JP)	726
Evasion	4	1761	73	05/1997	07/2002	LFZ (XU7JP)	726
Evasion	4	1997	100	05/2000	07/2002	RFN (EW10J4)	746
Evasion	4	1998	89	06/1994	07/2002	RFU (XU10J2/C)	764
Evasion	4	1998	108	06/1994	07/2002	RGX (XU10J2TE)	764
Evasion	4	1998	97	05/1998	04/2000	RFV (XU10J4R)	764
Evasion HDI	4	1997	80	08/1999	10/2002	RHW (DW10ATED4) RHZ (DW10ATED)	752 758
Evasion TD	4	1905	66	11/1994	07/2002	D8B (XUD9TE) D8B (XUD9TF) DHX (XUD9TF/ BTF)	740
Evasion TD	4	1905	68	10/1995	12/1998	D8B (XUD9TE) D8B (XUD9TF)	740
Evasion TD	4	2088	80	05/1996	07/2002	P8C (XUD11BTE)	768
Grand C4	3	1199	96	04/2018		HNS (EB2ADTS) HNY (EB2DTS)	688 690
Grand C4	4	1598	110	04/2018		5GX (EP6FDTMD)	724
Grand C4	4	1598	121	04/2018		5GZ (EP6FDT)	724
Grand C4	4	1598	133	04/2018		5GF (EP6FADTXD)	722
Grand C4 HDI	4	1499	96	05/2018		YHZ (DV5RC)	702
Grand C4 HDI	4	1560	73	04/2018		BHY (DV6FD)	712
Grand C4 HDI	4	1560	85	04/2018		9HC (DV6C)	706
Grand C4 HDI	4	1560	88	04/2018		BHZ (DV6FC)	712
Grand C4 HDI	4	1997	110	04/2018		AHR (DW10FD) AHX (DW10FD)	744
Grand C4 HDI	4	1997	120	04/2018		EHY (DW10FCC)	744
Jumper	4	1998	80	02/1994	04/2002	RFW (XU10J2U)	766
Jumper	4	1998	81	04/2002		XU10J2	766

CITROËN	ccm	kW	→	→			
Jumper D	4	1905	51	02/1994	04/2002	D9B (XUD9AU)	736
Jumper D	4	1905	50	07/1999	04/2002	DJY (XUD9A)	736
Jumper D	4	2446	63	03/1994	04/2002	T9A (DJ5)	778
Jumper D	4	2798	64	01/1999	02/2002	8140.63 (F28D)	784
Jumper HDI	4	1997	62	11/2001		RHV (DW10TD) RHW (DW10UTD)	750
Jumper HDI	4	1997	81	07/2015	09/2019	AHM (DW10FUE)	742
Jumper HDI	4	1997	96	07/2015	09/2019	AHN (DW10FUD)	742
Jumper HDI	4	1997	120	07/2015	09/2019	AHP (DW10FUC)	742
Jumper HDI	4	2179	74	02/2002		4HY (DW12UTED)	774
Jumper HDI	4	2179	88	08/2019		4HK (DW12RUE)	770
Jumper HDI	4	2179	103	08/2019		4HB (DW12RUD)	770
Jumper HDI	4	2179	121	08/2019		4HH (DW12RUC)	770
Jumper HDI	4	2198	74	04/2006		4HV (P22DTE)	776
Jumper HDI	4	2198	88	04/2006		4HU (P22DTE)	776
Jumper HDI	4	2198	81	07/2011		4HG (P22DTE)	776
Jumper HDI	4	2198	96	07/2011		4HH (P22DTE)	776
Jumper HDI	4	2198	110	07/2011		4HJ (P22DTE)	776
Jumper HDI	4	2287	93	08/2008		F1AE0481T	778
Jumper HDI	4	2798	94	09/2000		8140.43S F28TDCR	784
Jumper HDI	4	2798	77	06/2003	06/2006	8140.43C	782
Jumper HDI	4	2798	107	05/2004		8140.43N	782
Jumper HDI	4	2798	89	07/2005	10/2010	8140.43S	784
Jumper HDI	4	2800	107	05/2004		8140.43N	782
Jumper HDI	4	2999	116	09/2006		F1CE0481D (F30DT)	786
Jumper HDI	4	2999	107	07/2010		F30DTE (F1CE3481N)	788
Jumper HDI	4	2999	115	07/2010		F1CE0481D (F30DT)	786
Jumper HDI	4	2999	130	07/2011		F1CE3481E (F30DTE)	788
Jumper TD	4	1905	68	02/1994	04/2002	D8C (XUD9UTF)	740
Jumper TD	4	1905	66	03/1994	04/2002	D8C (XUD9UTF) DHX (XUD9TF/ BTF)	740

CITROËN

CITROËN



CITROËN	ccm	kW	→	→	→	→	→
Jumper TD	4	2446	76	03/1994	04/2002	T8A (DJ5T) THZ (DJ5T)	778
Jumper TD	4	2446	79	12/1996	04/2002	THX (DJ5TED)	780
Jumpy	4	1581	58	10/1995	08/2000	1580 SPI 220 A2.000	714
Jumpy	4	1997	102	03/2000	10/2006	RFN (EW10J4)	746
Jumpy	4	1997	100	04/2000	12/2006	RFN (EW10J4)	746
Jumpy	4	1997	103	01/2007	03/2016	RFH (EW10A) RFJ (EW10A)	744
Jumpy D	4	1868	51	04/1998	10/2006	WJY (DW8B) WJZ (DW8)	732
Jumpy D	4	1905	51	10/1995	08/1998	D9B (XUD9A/U)	736
Jumpy HDI	4	1499	75	06/2018		YHR (DV5RUCd)	704
Jumpy HDI	4	1499	88	06/2018		YHV (DV5RUC)	704
Jumpy HDI	4	1560	66	01/2007		9HF (DV6DU) 9HH (DV6DUM) 9HM (DV6UC) 9HU (DV6UTED4)	706 710
Jumpy HDI	4	1560	70	04/2016		BHS (DV6FDU) BHV (DV6FDU)	712
Jumpy HDI	4	1560	85	04/2016		BHX (DV6FCU)	712
Jumpy HDI	4	1997	69	10/1999	10/2006	RHX (DW10BTED)	754
Jumpy HDI	4	1997	80	03/2000	10/2006	RHW (DW10ATED4) RHZ (DW10ATED) RHZ (DW10BTED) RHZ (DW10BTED+) RHZ (DW10CTED) RHZ (DW10CTED+)	752 758 760
Jumpy HDI	4	1997	88	01/2007	03/2016	RHK (DW10UTED4)	748
Jumpy HDI	4	1997	100	01/2007	03/2016	RHR (DW10BTED4)	748
Jumpy HDI	4	1997	120	07/2010	03/2016	RHH (DW10CTED4)	746
Jumpy HDI	4	1997	72	07/2011	03/2016	AHY (DW10CE)	746
Jumpy HDI	4	1997	94	07/2011		AHZ (DW10CD)	746
Jumpy HDI	4	1997	90	04/2016		AHK (DW10FE)	744
Jumpy HDI	4	1997	110	04/2016		AHX (DW10FD)	744
Jumpy HDI	4	1997	130	04/2016		AHH (DW10FC) EHZ (DW10FDCU)	744

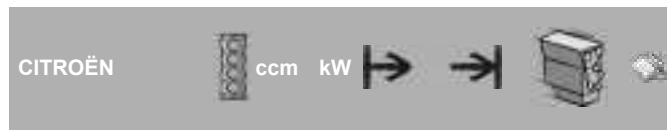

Jumpy HDI	4	1997	106	08/2021		EHS (DW10FDDU370)) EHT (DW10FDDU340))	744
Jumpy TD	4	1868	51	11/2000	10/2006	WJY (DW8B)	732
Jumpy TD	4	1905	66	10/1995	08/2000	DHX (XUD9TF/ BTF)	740
Jumpy TD	4	1905	68	10/1995	10/2006	D8B (XUD9TE) D8B (XUD9TF)	740
Nemo	4	1360	54	02/2008		KFT (TU3A) KFV (TU3A)	696
Nemo HDI	4	1248	55	10/2010		FHZ (F13DTE5)	690
Nemo HDI	4	1248	59	10/2015		FHY (F13DTE6)	690
Nemo HDI	4	1398	50	02/2008		8HS (DV4TED)	700
Nemo HDI	4	1399	50	04/2009		8HS (DV4TED)	700
Saxo	4	954	33	05/1996	06/2003	CDY (TU9M) CDZ (TU9M)	684
Saxo	4	954	37	05/1998	06/2003	CDZ (TU9M)	684
Saxo	4	1124	40	05/1996	09/2003	HDZ (TU1M)	686
Saxo	4	1124	44	05/1996	09/2003	HDZ (TU1M) HFV (TU1JP)	686
Saxo	4	1360	55	05/1996	06/2003	KFW (TU3JP) KFX (TU3JP)	696
Saxo	4	1587	66	02/1996	06/2003	NFZ (TU5JP)	718
Saxo	4	1587	88	02/1996	04/2004	NFX (TU5JP4)	718
Saxo	4	1587	65	05/1996	06/2003	NFZ (TU5JP)	718
Saxo	4	1587	80	05/1996	07/1999	NFX (TU5JP4)	718
Saxo	4	1587	87	06/1996	09/2003	NFX (TU5JP4)	718
Saxo	4	1587	72	09/2000	09/2003	NFT (TU5JP)	718
Saxo	4	1587	74	02/2001	04/2004	NFT (TU5JP)	718
Saxo D	4	1527	40	09/1996	09/2003	VJY (TUD5)	704
Saxo D	4	1527	42	09/1996	06/2001	VJZ (TUD5)	704
Saxo D	4	1527	43	07/2001	04/2004	VJZ (TUD5)	704
Spacetourer HDI	4	1499	75	06/2018		YHR (DV5RUCd)	704
Spacetourer HDI	4	1499	88	06/2018		YHV (DV5RUC)	704
Spacetourer HDI	4	1560	70	04/2016		BHS (DV6FDU) BHV (DV6FDU)	712
Spacetourer HDI	4	1560	85	04/2016		BHX (DV6FCU)	712
Spacetourer HDI	4	1560	66	07/2018		9HF (DV6DU)	706
Spacetourer HDI	4	1997	110	04/2016		AHX (DW10FD)	744



CITROËN	ccm	kW	→	→		
Spacetourer HDI	4	1997	130	04/2016	AHH (DW10FC) EHZ (DW10FDCU)	744
Spacetourer HDI	4	1997	90	12/2019	AHK (DW10FE)	744
Spacetourer HDI	4	1997	106	09/2020	EHS (DW10FDDU370)) EHT (DW10FDDU340))	744
Visa	4	1580	76	01/1985	06/1986	180A (XU5J) 712
Visa	4	1580	83	06/1986	03/1991	B6D 712
Visa	4	1769	44	04/1984	03/1991	161A (XUD7) 728
Xantia	4	1580	65	03/1993	03/2001	BFZ (XU5JP) 714
Xantia	4	1761	74	03/1993	01/1998	LFZ (XU7JP) 726
Xantia	4	1761	81	06/1995	04/2003	LFY (XU7JP4) 726
Xantia	4	1761	66	04/1997	04/2003	LFX (XU7JB) 726
Xantia	4	1998	89	03/1993	04/2003	RFX (XU10J2C) 764
Xantia	4	1998	95	03/1993	05/1995	RFX XU10J2C/Z L3 764
Xantia	4	1998	112	03/1993	01/1998	RFY (XU10J4Z) 762
Xantia	4	1998	90	01/1994	12/1998	RFX (XU10J2C) 764
Xantia	4	1998	110	06/1994	01/1998	RFT (XU10J4Z) 762
Xantia	4	1998	97	06/1995	04/2003	RFV (XU10J4R) 764
Xantia	4	1998	108	06/1995	04/2003	RGX (XU10J2TE) 764
Xantia	4	1998	99	06/1998	11/2000	RFV (XU10J4R) 764
Xantia	6	2946	140	01/1997	04/2003	XFZ (ES9J4) 786
Xantia	6	2946	142	01/1998	04/2003	XFZ (ES9J4) 786
Xantia D	4	1905	50	06/1994	01/1998	DJZ (XUD9A) 736
Xantia D	4	1905	51	06/1994	01/1998	D9B (XUD9A/L) 736
Xantia HDI	4	1997	80	02/1999	04/2003	RHZ (DW10ATED) 758
Xantia HDI	4	1997	66	03/1999	04/2003	RHY (DW10TD) 756
Xantia SD	4	1905	55	02/1996	04/2003	DHW (XUD9SD) 738
Xantia TD	4	1905	66	05/1993	04/2003	D8B (XUD9TF) DHX (XUD9TF/ BTF) DHY (XUD9TE/Y) 740
Xantia TD	4	2088	80	06/1995	02/1999	P8C (XUD11BTE) 768
XM	4	1998	79	05/1989	04/1994	RDZ (XU10MZ) XU102C 762
XM	4	1998	84	05/1989	04/1994	XU10J 766

CITROËN	ccm	kW	→	→		
XM	4	1998	89	05/1989	07/1999	RFZ (XU10J2) XU10J2 762 766
XM	4	1998	94	05/1989	06/1994	R6A 762
XM	4	1998	99	05/1989	06/1994	RFV (XU10J4R) 764
XM	4	1998	85	10/1991	07/1994	XU10J 766
XM	4	1998	104	09/1992	06/1994	RGY (XU10J2TE/Z) 764
XM	4	1998	97	05/1994	10/2000	RFV (XU10J4R) 764
XM	4	1998	108	05/1994	10/2000	RGX (XU10J2TE) RGY (XU10J2TE/Z) 764
XM	6	2946	140	04/1997	10/2000	XFZ (ES9J4) 786
XM D	4	2138	60	05/1989	08/1996	P9A (XUD11A) 768
XM TD	4	2088	80	05/1989	10/2000	P8A (XUD11ATE) P8C (XUD11BTE) PHZ (XUD11ATE) PJZ (XUD11ATE) 768
XM TD	4	2446	95	05/1994	10/2000	THY (DK5ATE) 778
Xsara	4	1360	55	04/1997	08/2005	KFW (TU3JP) KFX (TU3JP) 696
Xsara	4	1587	65	04/1997	09/2000	NFZ (TU5JP) 718
Xsara	4	1587	80	09/2000	08/2005	NFU (TU5JP4) 716
Xsara	4	1749	85	08/1998	10/2004	6FZ (EW7J4) 724
Xsara	4	1761	66	04/1997	09/2000	LFX (XU7JB) 726
Xsara	4	1761	74	04/1997	09/2000	LFZ (XU7JP) 726
Xsara	4	1761	81	04/1997	09/2000	LFY (XU7JP4) 726
Xsara	4	1761	82	07/1997	08/2000	LFY (XU7JP4) 726
Xsara	4	1997	100	09/2000	08/2005	RFN (EW10J4) 746
Xsara	4	1998	123	01/1998	12/2002	RFS (XU10J4RS) 762
Xsara	4	1998	120	02/1998	03/2005	RFS (XU10J4RS) 762
Xsara	4	1998	97	07/1998	09/2000	RFV (XU10J4R) 764
Xsara	4	1998	122	05/2001	03/2004	RFS (XU10J4RS) 762
Xsara D	4	1527	42	04/1997	09/2000	VJZ (TUD5) 704
Xsara D	4	1769	43	04/1997	09/2000	161A (XUD7) A9A (XUD7) 728 730
Xsara D	4	1868	51	07/1998	08/2005	WJY (DW8B) WJZ (DW8) 732
Xsara D	4	1868	52	04/2000	04/2005	WJY (DW8B) 732

CITROËN



CITROËN	ccm	kW	→	→			
Xsara D	4	1905	50	04/1997	09/2000	DJY (XUD9A)	736
Xsara D	4	1905	55	02/1998	05/1999	DHV (XUD9BSD)	738
Xsara HDI	4	1398	50	01/2003	08/2005	8HX (DV4TD)	700
Xsara HDI	4	1997	66	02/1999	08/2005	RHY (DW10TD)	756
Xsara HDI	4	1997	80	05/2001	08/2005	RHZ (DW10ATED)	758
Xsara Picasso	4	1587	65	12/1999	09/2001	NFZ (TU5JP)	718
Xsara Picasso	4	1587	70	12/1999	12/2010	NFV (TU5JP)	718
Xsara Picasso	4	1587	74	04/2001	10/2004	NFV (TU5JP)	718
Xsara Picasso	4	1587	67	06/2002	08/2005	NFZ (TU5JP)	718
Xsara Picasso	4	1587	81	06/2005	06/2012	NFU (TU5JP4)	716
Xsara Picasso	4	1587	80	09/2005	12/2011	NFU (TU5JP4)	716
Xsara Picasso	4	1587	83	10/2006	06/2012	NFU (TU5JP4)	716
Xsara Picasso	4	1749	85	02/2000	08/2005	6FZ (EW7J4)	724
Xsara Picasso	4	1761	76	06/2000	08/2005	LFY (XU7JP4)	726
Xsara Picasso	4	1997	101	12/1999	11/2011	RFN (EW10J4)	746
Xsara Picasso	4	1997	100	01/2003	06/2012	RFN (EW10J4)	746
Xsara Picasso	4	1997	88	02/2004	10/2004	RFN (EW10J4)	746
Xsara Picasso HDI	4	1560	80	05/2004	12/2011	9HY (DV6TED4) 9HZ (DV6TED4)	710
Xsara Picasso HDI	4	1560	66	09/2005	12/2011	9HX (DV6ATED4)	710
Xsara Picasso HDI	4	1997	66	12/1999	12/2011	RHY (DW10TD)	756
Xsara Picasso HDI	4	1997	76	10/2005	12/2011	RHM (DW10ATED4)	752
Xsara SD	4	1905	55	01/1998	09/2000	DHV (XUD9BSD)	738
Xsara TD	4	1905	66	04/1997	09/2000	DHY (XUD9TE/Y)	740
Xsara TD	4	1905	65	05/1998	08/2000	DHY (XUD9TE/Y)	740
ZX	4	1124	40	03/1991	08/1993	H1A H1B	686
ZX	4	1124	44	03/1991	06/1997	HDZ (TU1M)	686
ZX	4	1360	55	03/1991	10/1997	KDX (TU3M/Z) KDY (TU3M) KDZ (TU3M/Z) KFX (TU3JP) TU32	692 696
ZX	4	1360	37	07/1994	10/1997	K9Y (TUD3Y)	692
ZX	4	1527	42	06/1996	02/1998	VJY (TUD5) VJZ (TUD5)	704

CITROËN	ccm	kW	→	→			
ZX	4	1580	65	03/1991	10/1997	BDY (XU5M) BFZ (XU5JP)	712 714
ZX	4	1580	66	07/1994	10/1997	BDY (XU5M) BFZ (XU5JP)	712 714
ZX	4	1761	76	03/1991	10/1997	LFZ (XU7JP)	726
ZX	4	1761	74	07/1992	10/1997	LFZ (XU7JP)	726
ZX	4	1761	81	01/1996	02/1998	LFY (XU7JP4)	726
ZX	4	1761	82	04/1996	10/1997	LFY (XU7JP4)	726
ZX	4	1905	88	03/1991	06/1997	DKZ (XU9JA)	734
ZX	4	1905	93	03/1991	06/1997	D6E (XU9JA)	734
ZX	4	1905	96	03/1991	09/1993	D6E (XU9JA)	734
ZX	4	1998	89	07/1992	06/1997	RFX XU10J2C/Z L3 RFX (XU10J2C)	764
ZX	4	1998	112	07/1992	10/1994	RFT (XU10J4/Z) RFY (XU10J4/Z)	762
ZX	4	1998	114	07/1992	10/1997	RFT (XU10J4/Z) RFY (XU10J4/Z)	762
ZX	4	1998	110	06/1994	06/1997	RFT (XU10J4/Z)	762
ZX	4	1998	90	07/1994	10/1997	RFX (XU10J2C)	764
ZX	4	1998	120	05/1996	06/1997	RFS (XU10J4RS)	762
ZX	4	1998	122	09/1996	10/1997	RFS (XU10J4RS)	762
ZX D	4	1769	44	06/1993	10/1997	161A (XUD7)	728
ZX D	4	1769	43	06/1996	10/1997	XUD7A	728
ZX D	4	1905	47	03/1991	10/1997	DJZ (XUD9A)	736
ZX D	4	1905	50	07/1993	10/1997	D9B (XUD9A/U) DJY (XUD9A)	736
ZX D	4	1905	52	10/1993	07/1999	D9B (XUD9A/L)	736
ZX TD	4	1905	68	06/1992	06/1994	DHY (XUD9TE/Y)	740
ZX TD	4	1905	66	07/1992	10/1997	DHY (XUD9TE/Y)	740
ZX TD	4	1905	65	07/1994	10/1997	DHY (XUD9TE/Y)	740

CITROËN



CITROËN



1580 SPI	4	1581	714
159A	4	1905	734
159B	4	1905	734
159K	4	1905	734
161 (XUD7)	4	1769	728
161A (XUD7)	4	1769	728
162 (XUD9)	4	1905	734
171A	4	1580	712
171B	4	1580	712
171C	4	1580	712
171D	4	1580	712
180A (XU5J)	4	1580	712
180Z	4	1580	712
182A	4	1580	712
220 A2.000	4	1581	714
3FY (EW12J4)	4	2230	778
3FZ (EW12J4)	4	2230	778
4A92	4	1590	720
4B11	4	1998	762
4B12	4	2360	778
4HB (DW12RUD)	4	2179	770
4HG (P22DTE)	4	2198	776
4HG (PUMA C)	4	2198	776
4HH (DW12RUC)	4	2179	770
4HH (P22DTE)	4	2198	776
4HH (PUMA C)	4	2198	776
4HJ (P22DTE)	4	2198	776
4HJ (PUMA C)	4	2198	776
4HK (DW12ME5)	4	2179	772
4HK (DW12RUE)	4	2179	770
4HL (DW12C)	4	2179	770
4HN (DW12MTED4)	4	2179	772
4HP (DW12BTED4)	4	2179	772

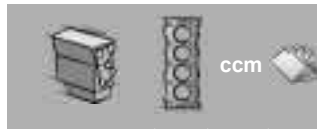

4HR (DW12BTED4)	4	2179	772
4HS (DW12BTED4)	4	2179	772
4HT (DW12BTED4)	4	2179	772
4HU (P22DTE)	4	2198	776
4HV (P22DTE)	4	2198	776
4HW (DW12TED4)	4	2179	772
4HX (DW12TED4)	4	2179	774
4HY (DW12UTED)	4	2179	774
4N13	4	1798	730
5F4 (EP6DT)	4	1598	720
5FA (EP6CDT)	4	1598	720
5FA (EP6CDTD)	4	1598	720
5FC (EP6CDTM)	4	1598	720
5FD (EP6DTS)	4	1598	720
5FE (EP6CDTMD)	4	1598	720
5FF (EP6DTS)	4	1598	720
5FK (EP6CB)	4	1598	722
5FM (EP6CDTM)	4	1598	720
5FM (EP6DT)	4	1598	720
5FN (EP6CDT)	4	1598	720
5FN (EP6DT)	4	1598	720
5FP (EP6)	4	1598	722
5FR (EP6DT)	4	1598	720
5FS (EP6C)	4	1598	722
5FT (EP6DT)	4	1598	720
5FU (EP6CDTX)	4	1598	722
5FU (EP6DTX)	4	1598	722
5FV (EP6CDT)	4	1598	720
5FW (EP6)	4	1598	722
5FX (EP6DT)	4	1598	720
5FY (EP6CDTX)	4	1598	720
5FY (EP6DT)	4	1598	720
5FY (EP6DTS)	4	1598	720



5GF (EP6FADTXD)	4	1598	722
5GX (EP6FDTMD)	4	1598	724
5GY (EP6FDTM)	4	1598	724
5GZ (EP6FDT)	4	1598	724
6FY (EW7A)	4	1749	724
6FZ (EW7J4)	4	1749	724
8140.43C	4	2798	782
8140.43N	4	2798	782
8140.43S	4	2798	784
8140.63 (F28D)	4	2798	784
8FN (EP3)	4	1397	698
8FP (EP3C)	4	1397	698
8FR (EP3)	4	1397	698
8FR (EP3C)	4	1397	698
8FS (EP3)	4	1397	698
8HP (DV4C)	4	1398	698
8HR (DV4C)	4	1398	698
8HS (DV4TED)	4	1398	700
8HT (DV4TD)	4	1398	700
8HX (DV4TD)	4	1398	700
8HY (DV4TED4)	4	1398	702
8HZ (DV4TD)	4	1398	700
9HC (DV6C)	4	1560	706
9HD (DV6C)	4	1560	706
9HE (DV6DBM)	4	1560	706
9HF (DV6DTE)	4	1560	706
9HF (DV6DU)	4	1560	706
9HF (DV6FDU)	4	1560	706
9HG (DV6C M)	4	1560	706
9HH (DV6DUM)	4	1560	706
9HJ (DV6DM)	4	1560	706
9HJ (DV6DTE)	4	1560	706
9HK (DV6ETEDM)	4	1560	706
9HL (DV6C)	4	1560	706
9HM (DV6UC)	4	1560	706

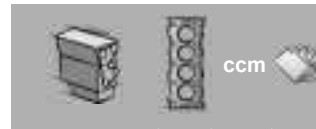

9HN (DV6ETED)	4	1560	706
9HP (DV6D)	4	1560	708
9HP (DV6DTE)	4	1560	708
9HR (DV6C)	4	1560	708
9HS (DV6TED4BU)	4	1560	710
9HT (DV6BTED4)	4	1560	710
9HT (DV6BUTED4)	4	1560	710
9HU (DV6UTED4)	4	1560	710
9HV (DV6TED4B)	4	1560	710
9HV (DV6TED4BU)	4	1560	710
9HW (DV6BTED4)	4	1560	710
9HX (DV6ATED4)	4	1560	710
9HX (DV6AUTED4)	4	1560	710
9HY (DV6TED4)	4	1560	710
9HZ (DV6TED4)	4	1560	710
A8A (XUD7TE)	4	1769	728
A9A (XUD7)	4	1769	730
AHE (DW10FD)	4	1997	744
AHF (DW10FD)	4	1997	744
AHG (DW10FD)	4	1997	744
AHH (DW10FC)	4	1997	744
AHJ (DW10FE)	4	1997	744
AHK (DW10FE)	4	1997	744
AHM (DW10FUE)	4	1997	742
AHN (DW10FUD)	4	1997	742
AHP (DW10FUC)	4	1997	742
AHR (DW10FD)	4	1997	744
AHS (DW10FD)	4	1997	744
AHT (DW10FC)	4	1997	744
AHU (DW10FCD)	4	1997	744



CITROËN



AHU (DW10FD)	4	1997	744
AHV (DW10FCD)	4	1997	744
AHV (DW10FD)	4	1997	744
AHW (DW10FC)	4	1997	744
AHX (DW10FCD)	4	1997	744
AHX (DW10FD)	4	1997	744
AHY (DW10CE)	4	1997	746
AHZ (DW10CD)	4	1997	746
AJZ (XUD7TE)	4	1769	728
B1A (XU51C/K)	4	1580	712
B1E (XU51C)	4	1580	712
B6D	4	1580	712
B6E	4	1580	712
BAY (XU5CP)	4	1580	712
BAZ (XU5CP)	4	1580	712
BDY (XU5M)	4	1580	712
BDZ (XU5M)	4	1580	712
BFZ (XU5JP)	4	1580	714
BHS (DV6FDU)	4	1560	712
BHT (DV6FC)	4	1560	712
BHU (DV6FC)	4	1560	712
BHV (DV6FDU)	4	1560	712
BHW (DV6FE)	4	1560	712
BHX (DV6FC)	4	1560	712
BHX (DV6FCU)	4	1560	712
BHY (DV6FD)	4	1560	712
BHZ (DV6FC)	4	1560	712
C1A	4	954	684
C1A (TU9/K)	4	954	684
C1B (TU9/W)	4	954	684
C3A	4	954	684
CDY (TU9M)	4	954	684
CDZ (TU9M)	4	954	684
CFA (384F)	3	998	684
CFB (1KR)	3	998	684
D2A (XU92C)	4	1905	734



D2C (XU92C)	4	1905	734
D2E	4	1905	734
D2F	4	1905	734
D6A (XU9J2)	4	1905	734
D6C	4	1905	734
D6C (XU9J4)	4	1905	734
D6E (XU9JA)	4	1905	734
D6U	4	1905	734
D8B (XUD9TE)	4	1905	740
D8B (XUD9TF)	4	1905	740
D8C (XUD9UTF)	4	1905	740
D9A (XUD9)	4	1905	734
D9B	4	1905	736
D9B (XUD9A/L)	4	1905	736
D9B (XUD9A/U)	4	1905	736
DDZ (XU9M)	4	1905	734
DFW (XU9J4)	4	1905	734
DFZ (XU9J1)	4	1905	734
DHV (XUD9BSD)	4	1905	738
DHW (XUD9SD)	4	1905	738
DHX (XUD9TF/BTF)	4	1905	740
DHY (XUD9TE/Y)	4	1905	740
DJY (XUD9A)	4	1905	736
DJZ (XUD9A)	4	1905	736
DKZ (XU9JA)	4	1905	734
DT17ED4	6	2720	780
DT20C	6	2993	786
DV4D	4	1398	700
DV6B	4	1560	710
DV6CTED	4	1560	706
EC5	4	1587	714
EHS (DW10FDDU370)	4	1997	744
EHT (DW10FDDU340)	4	1997	744



EHW (DW10FCD)	4	1997	744
EHY (DW10FCC)	4	1997	744
EHZ (DW10FC)	4	1997	744
EHZ (DW10FDCU)	4	1997	744
ES9J4SHP	6	2946	784
F1AE0481T	4	2287	778
F1CE0481 (30DT)	4	2999	786
F1CE0481D (F30DT)	4	2999	786
F1CE3481E (F30DTE)	4	2999	788
F28TDCR	4	2798	784
F30DTE (F1CE3481N)	4	2999	788
FHY (F13DTE6)	4	1248	690
FHZ (F13DTE5)	4	1248	690
H1A	4	1124	686
H1B	4	1124	686
HAZ (TU1CP)	4	1124	686
HDZ (TU1M)	4	1124	686
HFV (TU1A)	4	1124	686
HFX (TU1A)	4	1124	686
HFX (TU1JP)	4	1124	686
HMM (EB2FAD)	3	1199	688
HMP (EB2FB)	3	1199	688
HMR (EB2FA)	3	1199	688
HMT (EB2D)	3	1199	688
HMU (EB2D)	3	1199	688
HMU (EB2FD)	3	1199	688
HMV (EB2M)	3	1199	688
HMX (EB2)	3	1199	688
HMY (EB2M)	3	1199	688
HMZ (EB2)	3	1199	688
HMZ (EB2F)	3	1199	688
HNE (EB2ADTD)	3	1199	688



HNJ (EB2ADTXM)	3	1199	688
HNK (EB2ADTD)	3	1199	688
HNN (EB2ADTX)	3	1199	688
HNP (EB2ADT)	3	1199	688
HNS (EB2ADTS)	3	1199	688
HNV (EB2DTM)	3	1199	690
HNX (EB2DTS)	3	1199	690
HNY (EB2DTS)	3	1199	690
HNZ (EB2DT)	3	1199	690
K1B	4	1360	692
K1F	4	1360	692
K1G	4	1360	692
K1H (TU3A)	4	1360	692
K2A	4	1360	692
K2B	4	1360	692
K3A	4	1360	692
K9A (TUD3)	4	1360	692
K9Y (TUD3Y)	4	1360	692
KAY (TU3CP)	4	1360	692
KAZ	4	1360	692
KDX (TU3M/Z)	4	1360	692
KDY (TU3FM)	4	1360	694
KDY (TU3M)	4	1360	692
KDZ (TU3M/Z)	4	1360	692
KFT (TU3A)	4	1360	696
KFT (TU3AE5)	4	1360	696
KFU (ET3J4)	4	1360	694
KFV (TU3A)	4	1360	696
KFV (TU3JP)	4	1360	694
KFW (TU3A)	4	1360	696
KFW (TU3JP)	4	1360	696
KFX (TU3A)	4	1360	696
KFX (TU3JP)	4	1360	696
KFY (TU3FJ2)	4	1360	696

CITROËN

CITROËN



KFZ (TU3FJ2/Z)	4	1360	696
KFZ (TU3FJ2)	4	1360	696
LFX (XU7JB)	4	1761	726
LFY (XU7JP4)	4	1761	726
LFZ (XU7JP)	4	1761	726
M4A	4	1294	692
N6A (TU5JP4)	4	1587	716
NFP (EC5)	4	1587	714
NFR (TU5JP4B)	4	1587	716
NFS (TU5JP4S)	4	1587	716
NFT (TU5JP)	4	1587	718
NFU (TU5JP4)	4	1587	716
NFV (TU5JP)	4	1587	718
NFX (TU5JP4)	4	1587	718
NFZ (TU5JP)	4	1587	718
NKZ (4A92)	4	1590	720
P8A (XUD11ATE)	4	2088	768
P8C (XUD11BTE)	4	2088	768
P9A (XUD11A)	4	2138	768
PHZ (XUD11ATE)	4	2088	768
PJZ (XUD11ATE)	4	2088	768
R6A	4	1998	762
RDZ (XU10MZ)	4	1998	762
RFH (EW10A)	4	1997	744
RFJ (EW10A)	4	1997	744
RFK (EW10J4S)	4	1997	746
RFN (EW10J4)	4	1997	746
RFS (XU10J4RS)	4	1998	762
RFT (XU10J4/Z)	4	1998	762
RFU (XU10J2/C)	4	1998	764
RFV (XU10J4R)	4	1998	764
RFW (XU10J2U)	4	1998	766
RFX (XU10J2C)	4	1998	764
RFX XU10J2C/Z L3	4	1998	764

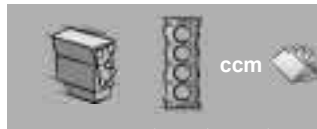

RFY (XU10J4/Z)	4	1998	762
RFZ (XU10J2)	4	1998	762
RGX (XU10J2TE)	4	1998	764
RGY (XU10J2TE/Z)	4	1998	764
RHA (DW10CTED4)	4	1997	746
RHC (DW10CTED4)	4	1997	746
RHD (DW10CB)	4	1997	746
RHD (DW10CTED4)	4	1997	746
RHE (DW10CDTR)	4	1997	746
RHE (DW10CTED4)	4	1997	746
RHF (DW10BTED4)	4	1997	748
RHH (DW10CTED4)	4	1997	746
RHJ (DW10BTED4)	4	1997	748
RHK (DW10UTED4)	4	1997	748
RHM (DW10ATED4)	4	1997	752
RHR (DW10BTED4)	4	1997	748
RHS (DW10ATED)	4	1997	756
RHT (DW10ATED4)	4	1997	752
RHV (DW10TD)	4	1997	750
RHV (DW10UTD)	4	1997	750
RHW (DW10ATED4)	4	1997	752
RHX (DW10BTED)	4	1997	754
RHY (DW10TD)	4	1997	756
RHZ (DW10ATED)	4	1997	758
RHZ (DW10BTED)	4	1997	760
RHZ (DW10BTED+)	4	1997	760



RHZ (DW10CTED)	4	1997	760
RHZ (DW10CTED+)	4	1997	760
RLZ (EW10D)	4	1997	760
SFZ (4B12 MMC)	4	2360	778
T8A (DJ5T)	4	2446	778
T9A (DJ5)	4	2446	778
THX (DJ5TED)	4	2446	780
THY (DK5ATE)	4	2446	778
THZ (DJ5T)	4	2446	778
TU32	4	1360	692
TU9	4	954	684
TU9K	4	954	684
UHZ (DT17BTED4)	6	2720	780
UHZ (DT17TED4)	6	2720	780
VJY (TUD5)	4	1527	704
VJZ (TUD5)	4	1527	704
WJX (DW8B)	4	1868	732
WJY (DW8B)	4	1868	732
WJZ (DW8)	4	1868	732
X8C (DT20C)	6	2993	786
XFU (ES9A)	6	2946	786
XFV (ES9A)	6	2946	786
AFX (ES9J4S)	6	2946	784
AFX (ES9J4)	6	2946	786
XU102C	4	1998	762
XU10J	4	1998	766
XU10J2	4	1998	766
XU52C	4	1580	712
XUD7A	4	1769	728
YHR (DV5RUCd)	4	1499	704
YHS (DV5RCE)	4	1499	702
YHT (DV5RCF)	4	1499	702
YHV (DV5RUC)	4	1499	704
YHW (DV5RE)	4	1499	704



YHX (DV5RC)	4	1499	702
YHY (DV5RD)	4	1499	704
YHZ (DV5RC)	4	1499	702
ZMZ (EB0)	3	999	684
ZMZ (EB0F)	3	999	684











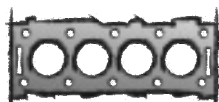
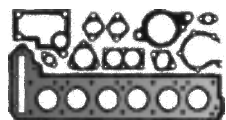









CITROËN

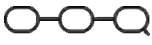

Das Original

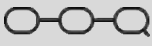
CITROËN

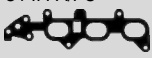

			<p>a) </p> <p>b) </p>	<p>K: </p> <p>N: </p>	
<p>VAS 825.042 FPM 701.289 0956.28 FPM 8x</p>	<p>388.151 0349.A6 2x </p>	<p>984.826 2x </p>	<p>a) 984.451  0164.30 CU C 16x22x2</p> <p>b) 813.052 0164.30 CU C 16x22x2</p>	<p>K:← 369.530 0514.A3 ASW RD PTFE/ACM 42x66x7 K:← 505.740 0514.72 ASW RD FPM/ACM 42x66x6 K:→ 135.110 0514.74 ASW LD FPM/ACM 85x105x9 K:→ 315.494 0514.40 ASW LD FPM/ACM 85x105x12 K:→ 369.470 0514.A2 ASW LD PTFE/ACM 85x105x8 N:← 505.366 0236.44 ASW RD FPM/ACM 36x50x7</p>	
<p>VAS 338.870</p>	<p>291.540 0349.L1 </p>	<p>290.930 0348.S4 </p>	<p>a) 036.164 Dirko HT / EU a) 510.031 Dirko HT / USA/CDN/MEX a) 527.291 Dirko HT / RU a) 648.661 Dirko HT / BR b) 877.960 incl. 473.500 6822.ER M 12x1,25x22 b) 473.500 6822.AG FI A 12x24x2</p>	<p>K:← 694.300 0321.97 AS RD FPM 38x50x6 K:→ 458.620 6822.X0 AS LD FPM 73x89x8,5 K:→ 848.390 16 128 780 80 AS LD FPM 73x89x8,5</p>	
<p>VAS 338.870</p>	<p>291.540 0349.L1 C1 PM </p>	<p>290.930 0348.S4 C1 PM  586.480 16 115 508 80 C1 II PA/PS  642.680 16 115 509 80 C1 II PA/PS </p>	<p>a) 036.164 Dirko HT / EU a) 510.031 Dirko HT / USA/CDN/MEX a) 527.291 Dirko HT / RU a) 648.661 Dirko HT / BR b) 877.960 incl. 473.500 6822.ER M 12x1,25x22 b) 473.500 6822.AG FI A 12x24x2</p>	<p>K:← 694.300 0321.97 AS RD FPM 38x50x6 K:→ 458.620 6822.X0 AS LD FPM 73x89x8,5 K:→ 848.390 16 128 780 80 AS LD FPM 73x89x8,5</p>	
<p>582.530 16 115 102 80 FPM 12x</p>	<p>598.610 96 880 312 80 </p>	<p>577.630 16 087 337 80 3x</p>	<p>a) 036.164 Dirko HT / EU a) 510.031 Dirko HT / USA/CDN/MEX a) 527.291 Dirko HT / RU a) 648.661 Dirko HT / BR b) 813.052 0164.30 CU C 16x22x2</p>	<p>K:← 004.450 0514.C8 ASW RD PTFE/ACM 61x75x8 K:→ 707.350 16 111 874 80 SP LD</p>	

CITROËN

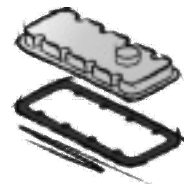
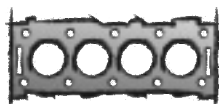
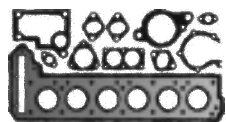

H1A
H1B
HAZ (TU1CP)

4 Cyl. **1124 ccm**
Cyl. 72,0 Ø

AX 09/1986 → 12/1997
BX 10/1986 → 06/1992
C 15 11/1988 → 07/1996
ZX 03/1991 → 08/1993

ES⊕ **529.060**
0197.H8
+0209.W6
ES⊕ **986.748**
0197.H8

CS* **984.125**

984.136
0209.CJ
1,27 mm $\frac{\pm}{\pm}$ 76 Ø
117.831
0209.W7
1,47 mm $\frac{\pm}{\pm}$ 76 Ø



ZKS 758.300
0204.83 (10x)
M 10x1,5x175



776.416
0249.54



HDZ (TU1M)

4 Cyl. **1124 ccm**
Cyl. 72,0 Ø

AX 09/1986 → 12/1997
Berlingo 07/1996 → 05/2008
BX 10/1988 → 06/1992
C 15 07/1988 → 12/1996
Saxo 05/1996 → 09/2003
ZX 03/1991 → 06/1997

ES⊕ **986.748**
0197.H8

ES⊕ **529.060**
0197.H8
+0209.W6
→09/1996
CS* **984.125**

984.136
0209.CJ
1,27 mm $\frac{\pm}{\pm}$ 76 Ø
→09/1996
117.831
0209.W7
1,47 mm $\frac{\pm}{\pm}$ 76 Ø
→09/1996



ZKS 758.300
0204.83 (10x)
M 10x1,5x175



776.416
0249.54



HFV (TU1A)
HFX (TU1A)/(TU1JP)

4 Cyl. **1124 ccm**
Cyl. 72,0 Ø

Berlingo 07/1996 → 05/2008
C2 09/2003 → 09/2012
C3 02/2002 →
Saxo 05/1996 → 09/2003

S⊕* **867.540**

ES⊕ **332.230**
L4 / Euro 3
ES⊕ **713.070**
Euro 4
CS* **984.125**

074.391
0209.Y0
1,26 mm $\frac{\pm}{\pm}$ 73,8 Ø
135.291
0209.Y1
1,47 mm $\frac{\pm}{\pm}$ 73,8 Ø

























ZKS 758.300
0204.83 (10x)
M 10x1,5x175





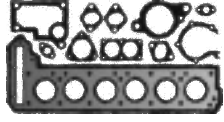
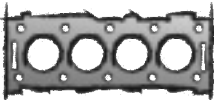

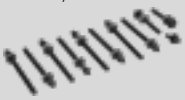
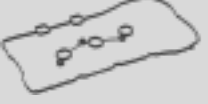
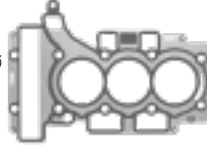
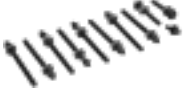

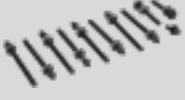















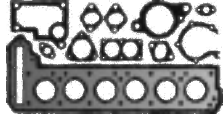
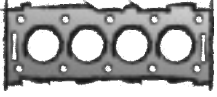



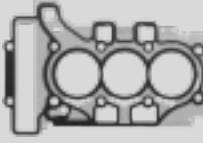





776.416
0249.54

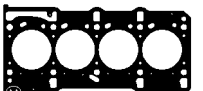
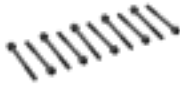
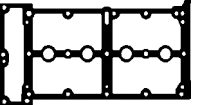







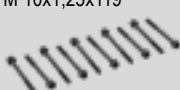
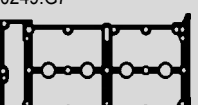







			<p>a) </p> <p>b) </p>	<p>K: </p> <p>N: </p>	
<p>VAS 825.042 FPM 701.289 0956.28 FPM 8x</p>	<p>388.151 0349.A6 2x </p>	<p>984.826 2x </p>	<p>a) 984.451 </p> <p>b) 813.052 0164.30 CU C 16x22x2</p>	<p>K:← 369.530 0514.A3 ASW RD PTFE/ACM 42x66x7 K:← 505.740 0514.72 ASW RD FPM/ACM 42x66x6 K:→ 135.110 0514.74 ASW LD FPM/ACM 85x105x9 K:→ 315.494 0514.40 ASW LD FPM/ACM 85x105x12 K:→ 369.470 0514.A2 ASW LD PTFE/ACM 85x105x8 N:← 505.366 0236.44 ASW RD FPM/ACM 36x50x7</p>	
<p>VAS 825.042 FPM 701.289 0956.28 FPM 8x</p>	<p>388.151 0349.A6 2x </p>	<p>984.826 2x </p>	<p>a) 984.451 </p> <p>b) 434.941 M 16x1,5x12 incl. 813.052 b) 813.052 0164.30 CU C 16x22x2 b) 834.823 0164.88 NBR A 16,7x24x1,5 FE/NBR</p>	<p>K:← 369.530 0514.A3 ASW RD PTFE/ACM 42x66x7 K:← 505.740 0514.72 ASW RD FPM/ACM 42x66x6 K:→ 135.110 0514.74 ASW LD FPM/ACM 85x105x9 K:→ 315.494 0514.40 ASW LD FPM/ACM 85x105x12 K:→ 369.470 0514.A2 ASW LD PTFE/ACM 85x105x8 N:← 505.366 0236.44 ASW RD FPM/ACM 36x50x7</p>	
<p>VAS 825.042 FPM 701.289 0956.28 FPM 8x</p>	<p>258.311 0349.K1 L4 Euro 3 (D3)  515.450 0349.J6 Euro 4 / FL5/L5 </p>	<p>258.620 0342.E0 4x </p>	<p>a) 984.451 </p> <p>b) 434.941 M 16x1,5x12 incl. 813.052 b) 813.052 0164.30 CU C 16x22x2 b) 834.823 0164.88 NBR A 16,7x24x1,5 FE/NBR</p>	<p>K:← 369.530 0514.A3 ASW RD PTFE/ACM 42x66x7 K:← 505.740 0514.72 ASW RD FPM/ACM 42x66x6 K:→ 135.110 0514.74 ASW LD FPM/ACM 85x105x9 K:→ 315.494 0514.40 ASW LD FPM/ACM 85x105x12 K:→ 369.470 0514.A2 ASW LD PTFE/ACM 85x105x8 N:← 505.366 0236.44 ASW RD FPM/ACM 36x50x7</p>	

<p>CITROËN</p> 				
<p>HMM (EB2FAD) HMR (EB2FA)</p> <p>3 Cyl. 1199 ccm Cyl. 75,0 Ø</p> <p>C3 07/2016 →</p> <p>C3 Aircross 06/2017 →</p> <p>C-Elysee 02/2018 →</p>			<p>ZKS 592.640 16 083 781 80 M 10x1,5x126</p> 	<p>ZKHS 634.660 96 778 553 80</p> 
<p>HMP (EB2FB) HMT (EB2D) HMU (EB2D)/(EB2FD) HMV (EB2M) HMX (EB2) HMY (EB2M) HMZ (EB2)/(EB2F)</p> <p>3 Cyl. 1199 ccm Cyl. 75,0 Ø</p> <p>C1 04/2014 →</p> <p>C3 06/2012 →</p> <p>C3 Aircross 06/2017 →</p> <p>C4 Cactus 09/2014 →</p> <p>C-Elysee 11/2012 →</p> <p>DS 3 01/2013 → 07/2015</p>	<p>S⊕* 928.990 ES⊕ 642.540 CS* 779.190</p>	<p>592.550 96 761 486 80 0,70 mm ± 76,3 Ø</p> 	<p>ZKS 592.640 16 083 781 80 M 10x1,5x126</p> 	<p>ZKHS 634.660 96 778 553 80</p> 
<p>HNE (EB2ADTD) HNJ (EB2ADTXM) HNK (EB2ADTD) HNN (EB2ADTX) HNP (EB2ADT) HNS (EB2ADTS)</p> <p>3 Cyl. 1199 ccm Cyl. 75,0 Ø</p> <p>Berlingo 06/2018 →</p> <p>C3 07/2016 →</p> <p>C3 Aircross 06/2017 →</p> <p>C4 10/2020 →</p> <p>C4 Cactus 09/2014 →</p> <p>C5 09/2021 →</p> <p>C5 Aircross 11/2018 →</p> <p>Grand C4 04/2018 →</p>	<p>CS* 968.160</p>		<p>ZKS 592.640 16 083 781 80 M 10x1,5x126</p> 	<p>461.682 EL-Liq 74</p> <p>534.720 98 176 433 80 ↑</p>

			<p>a) </p> <p>b) </p>	<p>K: </p> <p>N: </p>	
<p>582.530 16 115 102 80 FPM 12x</p>	<p>598.610 96 880 312 80</p> 	<p>577.630 16 087 337 80 3x</p>	<p>a) 036.164 Dirko HT / EU</p> <p>a) 510.031 Dirko HT / USA/CDN/MEX</p> <p>a) 527.291 Dirko HT / RU</p> <p>a) 648.661 Dirko HT / BR</p> <p>b) 813.052 0164.30 CU C 16x22x2</p>	<p>K:← 004.450 0514.C8 ASW RD PTFE/ACM 61x75x8</p> <p>K:→ 707.350 16 111 874 80 SP LD</p>	
<p>582.530 16 115 102 80 FPM 12x</p>	<p>598.610 96 880 312 80</p> 	<p>577.630 16 087 337 80 3x</p>	<p>a) 036.164 Dirko HT / EU</p> <p>a) 510.031 Dirko HT / USA/CDN/MEX</p> <p>a) 527.291 Dirko HT / RU</p> <p>a) 648.661 Dirko HT / BR</p> <p>b) 813.052 0164.30 CU C 16x22x2</p>	<p>K:← 004.450 0514.C8 ASW RD PTFE/ACM 61x75x8</p> <p>K:→ 707.350 16 111 874 80 SP LD</p>	
<p>582.530 16 115 102 80 FPM 12x</p>	<p>797.800 98 177 924 80</p> 	<p>577.540 98 039 185 80</p>	<p>a) 036.164 Dirko HT / EU</p> <p>a) 510.031 Dirko HT / USA/CDN/MEX</p> <p>a) 527.291 Dirko HT / RU</p> <p>a) 589.080 98 224 736 80</p> <p>a) 648.661 Dirko HT / BR</p> <p>b) 813.052 0164.30 CU C 16x22x2</p>	<p>K:← 004.450 0514.C8 ASW RD PTFE/ACM 61x75x8</p> <p>K:→ 707.350 16 111 874 80 SP LD</p>	<p>TLS 503.400</p>

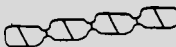
<p>CITROËN</p> 				
<p>HNV (EB2DTM) HNX (EB2DTSD) HNZ (EB2DTS) HNZ (EB2DT)</p> <p>3 Cyl. 1199 ccm Cyl. 75,0 Ø</p> <p>Berlingo 02/2016 →</p> <p>C3 10/2014 →</p> <p>C3 Aircross 06/2017 →</p> <p>C3 Picasso 01/2015 →</p> <p>C4 04/2014 →</p> <p>C4 Cactus 09/2014 →</p> <p>C4 Picasso 04/2014 →</p> <p>C4 Spacetourer 04/2018 →</p> <p>DS 3 10/2014 → 07/2015</p> <p>DS 4 07/2014 → 07/2015</p> <p>Grand C4 04/2018 →</p>	<p>ES⊕ 911.360</p>  <p>CS* 779.200</p>	<p>650.050 98 046 173 80 0,82 mm $\frac{2}{3}$ 76,3 Ø</p> 	<p>ZKS 592.640 16 083 781 80 M 10x1,5x126</p> 	<p>461.682 EL-Liq 74 582.580 98 025 959 80 ↑</p> 
<p>FHY (F13DTE6)</p> <p>4 Cyl. 1248 ccm Cyl. 69,6 Ø</p> <p>Nemo HDI 10/2015 →</p>	<p>ES⊕ 431.401</p>  <p>CS* 397.470</p>	<p>076.348  0,028 mm → 0,127 mm 0,72 mm $\frac{2}{3}$ 70,6 Ø</p> <p>076.358  0,128 mm → 0,227 mm 0,82 mm $\frac{2}{3}$ 70,6 Ø 1 ⊗</p> <p>076.408  0,228 mm → 0,327 mm 0,92 mm $\frac{2}{3}$ 70,6 Ø 2 ⊗</p>   	<p>ZKS 374.240 0250.C6 (10x) M 10x1,25x119</p> 	<p>074.173 0249.G7</p> 
<p>FHZ (F13DTE5)</p> <p>4 Cyl. 1248 ccm Cyl. 69,6 Ø</p> <p>Nemo HDI 10/2010 →</p>	<p>ES⊕ 431.401</p>  <p>CS* 397.470</p>	<p>076.348  0,028 mm → 0,127 mm 0,72 mm $\frac{2}{3}$ 70,6 Ø</p> <p>076.358  0,128 mm → 0,227 mm 0,82 mm $\frac{2}{3}$ 70,6 Ø 1 ⊗</p> <p>076.408  0,228 mm → 0,327 mm 0,92 mm $\frac{2}{3}$ 70,6 Ø 2 ⊗</p>   	<p>ZKS 374.240 0250.C6 (10x) M 10x1,25x119</p> 	<p>074.173 0249.G7</p> 

			<p>a) </p> <p>b) </p>	<p>K: </p> <p>N: </p>	
<p>582.530 16 115 102 80 FPM 12x</p>	<p>790.323 98 087 728 80</p> 	<p>577.540 98 039 185 80</p>	<p>a) 036.164 Dirko HT / EU</p> <p>a) 510.031 Dirko HT / USA/CDN/MEX</p> <p>a) 527.291 Dirko HT / RU</p> <p>a) 589.080 98 224 736 80</p> <p>a) 648.661 Dirko HT / BR</p> <p>b) 813.052 0164.30 CU C 16x22x2</p>	<p>K:← 004.450 0514.C8 ASW RD PTFE/ACM 61x75x8</p> <p>K:→ 707.350 16 111 874 80 SP LD</p>	<p>TLS 642.550</p>
<p>VAS 445.100 FPM</p>	<p>431.310 0349.P2</p> 	<p>718.200 4x</p> 	<p>a) 030.793 Dirko HT</p>	<p>K:← 445.060 0321.A1 AW/BS RD FPM 40x52x7</p> <p>K:→ 428.970 0127.55 ASW LD PTFE/ACM 78x100x9</p>	
<p>VAS 445.100 FPM</p>	<p>431.310 0349.P2</p> 	<p>431.180 0348.W2</p> 	<p>a) 030.793 Dirko HT</p>	<p>K:← 445.060 0321.A1 AW/BS RD FPM 40x52x7</p> <p>K:→ 428.970 0127.55 ASW LD PTFE/ACM 78x100x9</p>	<p>TLS 007.810</p> 

CITROËN

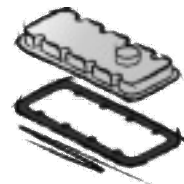
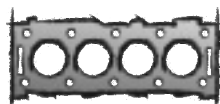
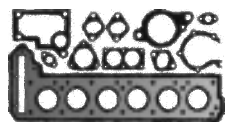



M4A
4 Cyl. **1294 ccm**
Cyl. 75,0 Ø

AX
04/1987 → 12/1988

ES⊕ **986.748**
0197.H8

CS* **984.125**

984.136
0209.CJ
1,27 mm $\frac{\pm}{\text{mm}}$ 76 Ø 

117.831
0209.W7
1,47 mm $\frac{\pm}{\text{mm}}$ 76 Ø 

ZKS 758.300
0204.83 (10x)
M 10x1,5x175



776.416
0249.54

K9A (TUD3)
K9Y (TUD3Y)
4 Cyl. **1360 ccm**
Cyl. 75,0 Ø

AX
09/1988 → 12/1997

ZX
07/1994 → 10/1997

S⊕* **828.425** ●
0197.K2

ES⊕ **984.118**
0197.K3

CS* **984.125**

900.001 ●
0209.N4
1,95 mm $\frac{\pm}{\text{mm}}$ 76 Ø 

ZKS 758.370
0204.84 (10x)
M 10x1,5x185

504.505
0249.76

K1B
K1F
K1G
K1H (TU3A)
K2A
K2B
K3A
KAY (TU3CP)
KAZ
KDX (TU3M/Z)
KDY (TU3M)
KDZ (TU3M/Z)
TU32
4 Cyl. **1360 ccm**
Cyl. 75,0 Ø

AX
09/1986 → 04/1997

BX
10/1982 → 02/1993

C 15
05/1987 → 12/1996

ZX
03/1991 → 10/1997

ES⊕ **529.060**
0197.H8
+0209.W6

ES⊕ **986.748**
0197.H8

CS* **984.125**















984.136
0209.CJ
1,27 mm $\frac{\pm}{\text{mm}}$ 76 Ø 

117.831
0209.W7
1,47 mm $\frac{\pm}{\text{mm}}$ 76 Ø 

ZKS 758.300
0204.83 (10x)
M 10x1,5x175

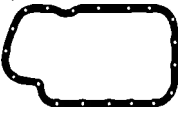
776.416
0249.54

CITROËN

			<p>a) </p> <p>b) </p>	<p>K: </p> <p>N: </p>	
<p>VAS 294.250 FPM 294.110 0956.22 FPM 8x</p>	<p>388.151 0349.A6 2x </p>		<p>a) 984.451 </p> <p>b) 813.052 0164.30 CU C 16x22x2</p>	<p>K:← 369.530 0514.A3 ASW RD PTFE/ACM 42x66x7 K:← 505.740 0514.72 ASW RD FPM/ACM 42x66x6 K:→ 135.110 0514.74 ASW LD FPM/ACM 85x105x9 K:→ 315.494 0514.40 ASW LD FPM/ACM 85x105x12 K:→ 369.470 0514.A2 ASW LD PTFE/ACM 85x105x8 N:← 505.366 0236.44 ASW RD FPM/ACM 36x50x7</p>	
<p>VAS 825.042 FPM 701.289 0956.28 FPM 8x</p>	<p>828.434 0349.E4 </p>		<p>a) 984.451 </p> <p>b) 813.052 0164.30 CU C 16x22x2</p>	<p>K:← 369.530 0514.A3 ASW RD PTFE/ACM 42x66x7 K:← 505.740 0514.72 ASW RD FPM/ACM 42x66x6 K:→ 135.110 0514.74 ASW LD FPM/ACM 85x105x9 K:→ 315.494 0514.40 ASW LD FPM/ACM 85x105x12 K:→ 369.470 0514.A2 ASW LD PTFE/ACM 85x105x8 N:← 505.366 0236.44 ASW RD FPM/ACM 36x50x7</p>	
<p>VAS 825.042 FPM 701.289 0956.28 FPM 8x</p>	<p>388.151 0349.A6 2x </p>	<p>984.826 2x </p>	<p>a) 984.451 </p> <p>b) 813.052 0164.30 CU C 16x22x2</p>	<p>K:← 369.530 0514.A3 ASW RD PTFE/ACM 42x66x7 K:← 505.740 0514.72 ASW RD FPM/ACM 42x66x6 K:→ 135.110 0514.74 ASW LD FPM/ACM 85x105x9 K:→ 315.494 0514.40 ASW LD FPM/ACM 85x105x12 K:→ 369.470 0514.A2 ASW LD PTFE/ACM 85x105x8 N:← 505.366 0236.44 ASW RD FPM/ACM 36x50x7</p>	

CITROËN

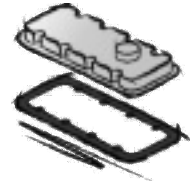
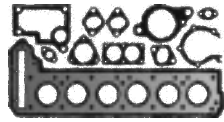

KDY (TU3FM)

4 Cyl. **1360 ccm**
Cyl. 75,0 Ø

AX

04/1987 → 04/1997

C 15

05/1991 → 12/1996

ES⊕ **141.931**
0197.J0



ES⊕ **218.841**
0197.J0

+0209.A9

CS* **218.850**

018.352

0209.A9

1,27 mm $\frac{1}{2}$ 76 Ø



193.222

0209.C1

1,47 mm $\frac{1}{2}$ 76 Ø



ZKS **758.300**

0204.83 (10x)

M 10x1,5x175



776.416

0249.54



KFU (ET3J4)

4 Cyl. **1360 ccm**
Cyl. 75,0 Ø

C2

04/2005 → 12/2009

C3

12/2003 →

C4

11/2004 → 07/2011

ES⊕ **505.300**

431.381

0209.FL

1,40 mm $\frac{1}{2}$ 76 Ø



ZKS **353.770**

0204.A5 (10x)

M 10x1,5x117

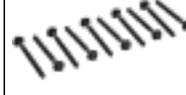

431.460

0249.E2

L

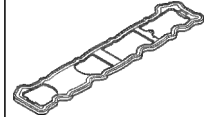

431.450

0249.C5

R

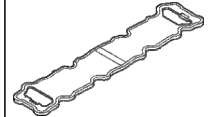

KFV (TU3JP)

4 Cyl. **1360 ccm**
Cyl. 75,0 Ø

C2

09/2003 → 12/2009

C3

02/2002 →

C3 Pluriel

05/2003 →

ES⊕ **505.250**
FL5/L5 / Euro 4 (D4)

CS* **984.125**

984.136

0209.CJ

1,27 mm $\frac{1}{2}$ 76 Ø

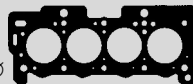

117.831

0209.W7

1,47 mm $\frac{1}{2}$ 76 Ø



ZKS **758.300**

0204.83 (10x)

















M 10x1,5x175



776.416









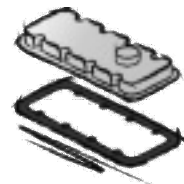
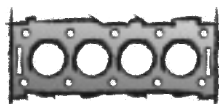
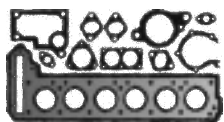









0249.54



			<p>a) </p> <p>b) </p>	<p>K: </p> <p>N: </p>	
<p>VAS 825.042 FPM 701.289 0956.28 FPM 8x</p>	<p>388.151 0349.A6 2x </p>	<p>984.826 2x </p>	<p>a) 773.740 </p> <p>b) 434.941 M 16x1,5x12 incl. 813.052</p> <p>b) 813.052 0164.30 CU C 16x22x2</p> <p>b) 834.823 0164.88 NBR A 16,7x24x1,5 FE/NBR</p>	<p>K:← 369.530 0514.A3 ASW RD PTFE/ACM 42x66x7</p> <p>K:← 505.740 0514.72 ASW RD FPM/ACM 42x66x6</p> <p>K:→ 135.110 0514.74 ASW LD FPM/ACM 85x105x9</p> <p>K:→ 315.494 0514.40 ASW LD FPM/ACM 85x105x12</p> <p>K:→ 369.470 0514.A2 ASW LD PTFE/ACM 85x105x8</p> <p>N:← 505.366 0236.44 ASW RD FPM/ACM 36x50x7</p>	
	<p>215.451 0349.L3 </p>	<p>497.360 0348.S1 4x </p>	<p>a) 036.164 Dirko HT / EU</p> <p>a) 510.031 Dirko HT / USA/CDN/MEX</p> <p>a) 527.291 Dirko HT / RU</p> <p>a) 648.661 Dirko HT / BR</p> <p>b) 813.052 0164.30 CU C 16x22x2</p>	<p>K:← 369.530 0514.A3 ASW RD PTFE/ACM 42x66x7</p> <p>K:← 505.740 0514.72 ASW RD FPM/ACM 42x66x6</p> <p>K:→ 369.470 0514.A2 ASW LD PTFE/ACM 85x105x8</p> <p>N:← 505.100 0807.32 ASW RD PTFE/ACM 36x50x8</p> <p>N:← 505.600 0807.33 ASW RD PTFE/ACM 24x50x8</p>	
<p>VAS 825.042 FPM 701.289 0956.28 FPM 8x</p>	<p>515.450 0349.J6 Euro 4 / FL5/L5 </p>	<p>258.620 0342.E0 4x </p>	<p>a) 984.451 </p> <p>b) 434.941 M 16x1,5x12 incl. 813.052</p> <p>b) 834.823 0164.88 NBR A 16,7x24x1,5 FE/NBR</p>	<p>K:← 369.530 0514.A3 ASW RD PTFE/ACM 42x66x7</p> <p>K:← 505.740 0514.72 ASW RD FPM/ACM 42x66x6</p> <p>K:→ 135.110 0514.74 ASW LD FPM/ACM 85x105x9</p> <p>K:→ 315.494 0514.40 ASW LD FPM/ACM 85x105x12</p> <p>K:→ 369.470 0514.A2 ASW LD PTFE/ACM 85x105x8</p> <p>N:← 505.100 0807.32 ASW RD PTFE/ACM 36x50x8</p> <p>N:← 505.366 0236.44 ASW RD FPM/ACM 36x50x7</p>	

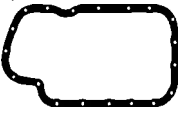







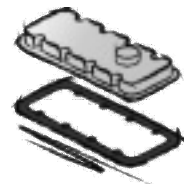
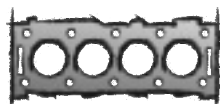
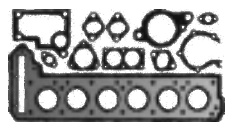







CITROËN



			<p>a) </p> <p>b) </p>	<p>K: </p> <p>N: </p>	
<p>VAS 825.042 FPM 701.289 0956.28 FPM 8x</p>	<p>258.311 0349.K1 L4 Euro 3 (D3)</p>  <p>388.151 0349.A6 D3 L3 2x</p>  <p>515.450 0349.J6 Euro 4 / FL5/L5</p> 	<p>258.620 0342.E0 4x</p> 	<p>a) 984.451</p>  <p>b) 434.941 M 16x1,5x12 incl. 813.052</p> <p>b) 834.823 0164.88 NBR A 16,7x24x1,5 FE/NBR</p>	<p>K:← 369.530 0514.A3 ASW RD PTFE/ACM 42x66x7</p> <p>K:← 505.740 0514.72 ASW RD FPM/ACM 42x66x6</p> <p>K:→ 135.110 0514.74 ASW LD FPM/ACM 85x105x9</p> <p>K:→ 315.494 0514.40 ASW LD FPM/ACM 85x105x12</p> <p>K:→ 369.470 0514.A2 ASW LD PTFE/ACM 85x105x8</p> <p>N:← 505.366 0236.44 ASW RD FPM/ACM 36x50x7</p>	
<p>VAS 825.042 FPM 701.289 0956.28 FPM 8x</p>	<p>258.311 0349.K1</p> 	<p>258.620 0342.E0 4x</p> 	<p>a) 984.451</p>  <p>b) 434.941 M 16x1,5x12 incl. 813.052</p> <p>b) 834.823 0164.88 NBR A 16,7x24x1,5 FE/NBR</p>	<p>K:← 369.530 0514.A3 ASW RD PTFE/ACM 42x66x7</p> <p>K:← 505.740 0514.72 ASW RD FPM/ACM 42x66x6</p> <p>K:→ 135.110 0514.74 ASW LD FPM/ACM 85x105x9</p> <p>K:→ 315.494 0514.40 ASW LD FPM/ACM 85x105x12</p> <p>K:→ 369.470 0514.A2 ASW LD PTFE/ACM 85x105x8</p> <p>N:← 505.100 0807.32 ASW RD PTFE/ACM 36x50x8</p> <p>N:← 505.366 0236.44 ASW RD FPM/ACM 36x50x7</p>	
<p>VAS 825.042 FPM 701.289 0956.28 FPM 8x</p>	<p>388.151 0349.A6 2x</p> 	<p>258.620 0342.E0 4x</p> 	<p>a) 773.740</p>  <p>b) 434.941 M 16x1,5x12 incl. 813.052</p> <p>b) 813.052 0164.30 CU C 16x22x2</p> <p>b) 834.823 0164.88 NBR A 16,7x24x1,5 FE/NBR</p>	<p>K:← 369.530 0514.A3 ASW RD PTFE/ACM 42x66x7</p> <p>K:← 505.740 0514.72 ASW RD FPM/ACM 42x66x6</p> <p>K:→ 135.110 0514.74 ASW LD FPM/ACM 85x105x9</p> <p>K:→ 315.494 0514.40 ASW LD FPM/ACM 85x105x12</p> <p>K:→ 369.470 0514.A2 ASW LD PTFE/ACM 85x105x8</p> <p>N:← 505.366 0236.44 ASW RD FPM/ACM 36x50x7</p>	

CITROËN



			<p>a) </p> <p>b) </p>	<p>K: </p> <p>N: </p>	
<p>VAS 747.210 0956.60 FPM</p>	<p>174.981 1723.CH</p> 	<p>895.440 0348.T4 4x</p> 	<p>a) 036.164 Dirko HT / EU</p> <p>a) 510.031 Dirko HT / USA/CDN/MEX</p> <p>a) 527.291 Dirko HT / RU</p> <p>a) 648.661 Dirko HT / BR</p> <p>b) 523.470 incl. 813.052 0311.39 M 16x1,5x16</p> <p>b) 813.052 0164.30 CU C 16x22x2</p>	<p>K:← 004.450 0514.C8 ASW RD PTFE/ACM 61x75x8</p> <p>K:→ 369.470 0514.A2 ASW LD PTFE/ACM 85x105x8</p>	
<p>VAS 261.330 FPM</p> <p>027.750 0956.50 FPM 8x</p>	<p>374.940 0349.N9</p> 	<p>341.080 0382.QW</p> 	<p>a) 036.164 Dirko HT / EU</p> <p>a) 510.031 Dirko HT / USA/CDN/MEX</p> <p>a) 527.291 Dirko HT / RU</p> <p>a) 648.661 Dirko HT / BR</p> <p>b) 877.930 incl. 108.502 M 10x1,25x13</p> <p>b) 108.502 0313.40 CU A 10x21x2,1</p>	<p>K:← 026.750 0127.42 ASW RD PTFE/FPM 40x55x6,4</p> <p>K:→ 026.790 0127.43 ASW LD PTFE/FPM 85x105x8,8</p> <p>N:← 026.740 0807.30 ASW RD PTFE/ACM 27x47x7</p>	<p>TLS 430.160</p> 
<p>VAS 261.330 FPM</p> <p>027.750 0956.50 FPM 8x</p>	<p>284.680 0349.N5 →05/2010</p>  <p>374.940 0349.N9 05/2010→</p> 	<p>341.080 0382.QW</p> 	<p>a) 036.164 Dirko HT / EU</p> <p>a) 510.031 Dirko HT / USA/CDN/MEX</p> <p>a) 527.291 Dirko HT / RU</p> <p>a) 648.661 Dirko HT / BR</p> <p>b) 877.930 incl. 108.502 M 10x1,25x13</p> <p>b) 108.502 0313.40 CU A 10x21x2,1</p>	<p>K:← 026.750 0127.42 ASW RD PTFE/FPM 40x55x6,4</p> <p>K:→ 026.790 0127.43 ASW LD PTFE/FPM 85x105x8,8</p> <p>N:← 026.740 0807.30 ASW RD PTFE/ACM 27x47x7</p>	<p>TLS 430.160</p> 

CITROËN

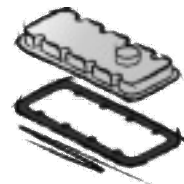
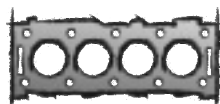
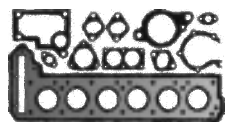

8HS (DV4TED)
8HT (DV4TD)
8HX (DV4TD)
8HZ (DV4TD)
DV4D

4 Cyl. **1398 ccm**
 Cyl. 73,7 Ø

C1 HDI
 06/2005 → 09/2014

C2 HDI
 07/2003 → 12/2009

C3 HDI
 02/2002 →

C3 Pluriel HDI
 04/2004 →

Nemo HDI
 02/2008 →

Xsara HDI
 01/2003 → 08/2005

S⊕* **726.090**



ES⊕ **030.760**



CS* **030.780**

OKS **027.170**

1104.36

OKS **747.080**



100.400

0209.AC

0,618 mm

→ 0,725 mm

1,25 mm $\frac{\pm}{\pm}$ 75 Ø

2 ▽

100.410

0209.AE

0,726 mm

→ 0,775 mm

1,30 mm $\frac{\pm}{\pm}$ 75 Ø

3 ▽

100.420

0209.AF

0,776 mm

→ 0,825 mm

1,35 mm $\frac{\pm}{\pm}$ 75 Ø

1 ▽

100.430

0209.AG

0,826 mm

→ 0,875 mm

1,40 mm $\frac{\pm}{\pm}$ 75 Ø

4 ▽

100.440

0209.AH

0,876 mm

→ 0,983 mm

1,45 mm $\frac{\pm}{\pm}$ 75 Ø

5 ▽

ZKS 330.390

0204.A4 (10x)

M 11x1,5x147











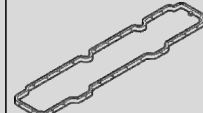

ZKHS 428.960







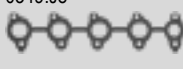



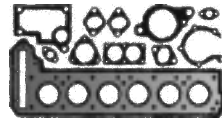
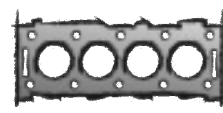

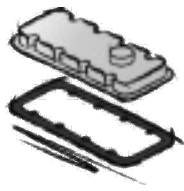











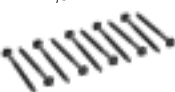







027.730

0249.C1

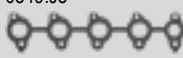









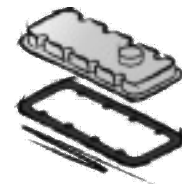
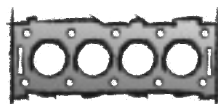
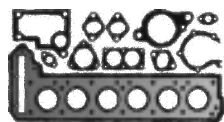



			<p>a) </p> <p>b) </p>	<p>K: </p> <p>N: </p>	
<p>VAS 261.330 FPM 027.750 0956.50 FPM 8x</p>	<p>761.041 0349.J8 </p>	<p>AAS 428.960  027.160 0348.R2 4x</p>	<p>a) 036.164 Dirko HT / EU a) 510.031 Dirko HT / USA/CDN/MEX a) 527.291 Dirko HT / RU a) 648.661 Dirko HT / BR b) 877.930 incl. 108.502 M 10x1,25x13 b) 108.502 0313.40 CU A 10x21x2,1</p>	<p>K:← 026.750 0127.42 ASW RD PTFE/FPM 40x55x6,4 K:→ 026.790 0127.43 ASW LD PTFE/FPM 85x105x8,8 N:← 026.740 0807.30 ASW RD PTFE/ACM 27x47x7</p>	<p>TLS 714.590 </p>

CITROËN 				
8HY (DV4TED4) 4 Cyl. 1398 ccm Cyl. 73,7 Ø C3 HDI 02/2002 →	ES⊕ 522.220  CS* 967.070  ES⊕ 967.050  CS* 967.060 OKS 907.240 98 142 946 80	862.602 0209.AJ  0,671 mm → 0,720 mm 1,25 mm $\frac{\pm}{\pm}$ 74,7 Ø 2 ▽ 862.612 0209.AK  0,721 mm → 0,770 mm 1,30 mm $\frac{\pm}{\pm}$ 74,7 Ø 3 ▽ 862.622 0209.AL  0,771 mm → 0,820 mm 1,35 mm $\frac{\pm}{\pm}$ 74,7 Ø 1 ▽ 862.632 0209.AN  0,821 mm → 0,870 mm 1,40 mm $\frac{\pm}{\pm}$ 74,7 Ø 4 ▽ 862.642 0209.AP  0,871 mm → 0,977 mm 1,45 mm $\frac{\pm}{\pm}$ 74,7 Ø 5 ▽	ZKS 330.390 0204.A4 (10x) M 11x1,5x147 	375.510 0249.C2 
YHS (DV5RCE) YHT (DV5RCF) YHX (DV5RC) YHZ (DV5RC) 4 Cyl. 1499 ccm Cyl. 75,0 Ø Berlingo HDI 06/2018 → C3 Aircross HDI 08/2018 → C4 Cactus HDI 09/2018 → C4 HDI 10/2020 → C4 Spacetourer HDI 05/2018 → C5 Aircross HDI 11/2018 → Grand C4 HDI 05/2018 →	CS* 967.070  ES⊕ 967.050  CS* 967.060 OKS 907.240 98 142 946 80	330.971 98 244 936 80 1,25 mm $\frac{\pm}{\pm}$ 76,3 Ø 2 ▽ 330.981 98 244 937 80 1,30 mm $\frac{\pm}{\pm}$ 76,3 Ø 3 ▽ 330.991 98 244 938 80 1,35 mm $\frac{\pm}{\pm}$ 76,3 Ø 1 ▽ 331.001 98 244 939 80 1,40 mm $\frac{\pm}{\pm}$ 76,3 Ø 4 ▽ 331.011 98 244 940 80 1,45 mm $\frac{\pm}{\pm}$ 76,3 Ø 5 ▽	ZKS 330.390 0204.A4 (10x) M 11x1,5x147 	ZKHS 907.170 16 235 002 80 929.060 98 173 808 80 4x 

			<p>a) </p> <p>b) </p>	<p>K: </p> <p>N: </p>	
<p>262.650 0956.51 FPM 16x</p>	<p>761.041 0349.J8</p> 	<p>AAS 429.040</p>  <p>389.041 0348.R5 4x</p>  <p>389.121 0348.R4 4x</p> 	<p>a) 036.164 Dirko HT / EU</p> <p>a) 510.031 Dirko HT / USA/CDN/MEX</p> <p>a) 527.291 Dirko HT / RU</p> <p>a) 648.661 Dirko HT / BR</p> <p>b) 877.930 incl. 108.502 M 10x1,25x13</p> <p>b) 108.502 0313.40 CU A 10x21x2,1</p>	<p>K:← 026.750 0127.42 ASW RD PTFE/FPM 40x55x6,4</p> <p>K:→ 026.790 0127.43 ASW LD PTFE/FPM 85x105x8,8</p> <p>N:← 026.740 0807.30 ASW RD PTFE/ACM 27x47x7</p>	<p>TLS 714.520</p> 
<p>910.610 98 100 557 80 FPM 16x</p> 			<p>a) 036.164 Dirko HT / EU</p> <p>a) 510.031 Dirko HT / USA/CDN/MEX</p> <p>a) 527.291 Dirko HT / RU</p> <p>a) 648.661 Dirko HT / BR</p>	<p>K:← 964.160 98 209 610 80 ASW RD PTFE/ACM 38x55x5,9</p> <p>K:→ 369.470 0514.A2 ASW LD PTFE/ACM 85x105x8</p> <p>N:← 966.950 98 239 200 80 ASW RD PTFE/ACM 24,7x42x6</p>	<p>TLS 929.580</p>

CITROËN



			<p>a) </p> <p>b) </p>	<p>K: </p> <p>N: </p>	
<p>910.610 98 100 557 80 FPM 16x</p> 			<p>a) 036.164 Dirko HT / EU</p> <p>a) 510.031 Dirko HT / USA/CDN/MEX</p> <p>a) 527.291 Dirko HT / RU</p> <p>a) 648.661 Dirko HT / BR</p>	<p>K:← 964.160 98 209 610 80 ASW RD PTFE/ACM 38x55x5,9</p> <p>K:→ 369.470 0514.A2 ASW LD PTFE/ACM 85x105x8</p> <p>N:← 966.950 98 239 200 80 ASW RD PTFE/ACM 24,7x42x6</p>	<p>TLS 929.580</p>
<p>910.610 98 100 557 80 FPM 16x</p> 			<p>a) 036.164 Dirko HT / EU</p> <p>a) 510.031 Dirko HT / USA/CDN/MEX</p> <p>a) 527.291 Dirko HT / RU</p> <p>a) 648.661 Dirko HT / BR</p>	<p>K:← 964.160 98 209 610 80 ASW RD PTFE/ACM 38x55x5,9</p> <p>K:→ 369.470 0514.A2 ASW LD PTFE/ACM 85x105x8</p> <p>N:← 966.950 98 239 200 80 ASW RD PTFE/ACM 24,7x42x6</p>	
<p>VAS 825.042 FPM</p> <p>701.289 0956.28 FPM 8x</p>	<p>828.434 0349.E4</p> 		<p>a) 773.740</p>  <p>b) 877.950 incl. 813.036 M 14x1,25x13</p> <p>b) 813.036 0313.27 CU C 14x20x2</p>	<p>K:← 369.530 0514.A3 ASW RD PTFE/ACM 42x66x7</p> <p>K:← 505.740 0514.72 ASW RD FPM/ACM 42x66x6</p> <p>K:→ 135.110 0514.74 ASW LD FPM/ACM 85x105x9</p> <p>K:→ 315.494 0514.40 ASW LD FPM/ACM 85x105x12</p> <p>K:→ 369.470 0514.A2 ASW LD PTFE/ACM 85x105x8</p> <p>N:← 505.366 0236.44 ASW RD FPM/ACM 36x50x7</p>	

CITROËN

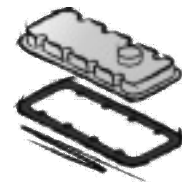
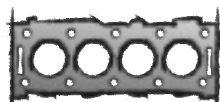
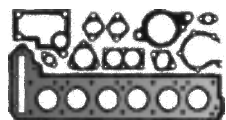

9HC (DV6C)
9HD (DV6C)
9HE (DV6DBM)
9HF (DV6DTEJ)/(DV6DUJ)
(DV6FDU)
9HG (DV6C M)
9HH (DV6DUM)
9HJ (DV6DM)/(DV6DTEJ)
9HK (DV6ETEDM)
9HL (DV6C)
9HM (DV6UC)
9HN (DV6ETED)
DV6CTED

4 Cyl. 1560 ccm
 Cyl. 75,0 Ø

Berlingo HDI

04/2008 →

C3 HDI

11/2009 →

C3 Picasso HDI

01/2013 →

C4 Aircross HDI

04/2012 →

C4 Cactus HDI

09/2014 →

C4 HDI

11/2009 →

C4 Picasso HDI

09/2010 →

C4 Spacetourer HDI

04/2018 →

C5 HDI

07/2010 →

C-Elysee HDI

11/2012 →

DS 3 HDI

08/2012 → 07/2015

DS 4 HDI

08/2012 → 07/2015

DS 5 HDI

06/2012 → 07/2015

Grand C4 HDI

04/2018 →

Jumpy HDI

01/2007 →

Spacetourer HDI

07/2018 →

S⊕* **726.090**



ES⊕ **570.910**
incl. 374.940



ES⊕ **995.620**



CS* **449.590**

OKS **027.170**

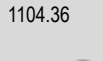

OKS **747.080**

718.311

0209.JN

1,25 mm \pm 76,3 Ø
2 ▽



718.321

0209.JP

1,30 mm \pm 76,3 Ø
3 ▽

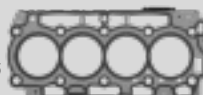

718.331

0209.JQ

1,35 mm \pm 76,3 Ø
1 ▽



718.341

0209.JR

1,40 mm \pm 76,3 Ø
4 ▽



718.351

0209.JS

1,45 mm \pm 76,3 Ø
5 ▽

ZKS **330.390**

0204.A4 (10x)











M 11x1,5x147



453.420

0249.G2

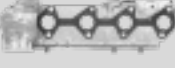

			<p>a) </p> <p>b) </p>	<p>K: </p> <p>N: </p>	
<p>VAS 261.330 FPM</p> <p>027.750 0956.50 FPM 8x</p>	<p>374.940 0349.N9</p> 	<p>341.080 0382.QW</p> 	<p>a) 036.164 Dirko HT / EU</p> <p>a) 510.031 Dirko HT / USA/CDN/MEX</p> <p>a) 527.291 Dirko HT / RU</p> <p>a) 648.661 Dirko HT / BR</p> <p>b) 877.930 incl. 108.502 M 10x1,25x13</p> <p>b) 108.502 0313.40 CU A 10x21x2,1</p>	<p>K:← 026.750 0127.42 ASW RD PTFE/FPM 40x55x6,4</p> <p>K:→ 026.790 0127.43 ASW LD PTFE/FPM 85x105x8,8</p> <p>N:← 026.740 0807.30 ASW RD PTFE/ACM 27x47x7</p>	<p>TLS 430.160</p> 

CITROËN

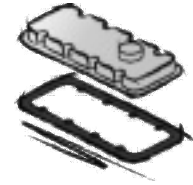
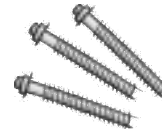
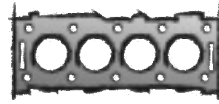
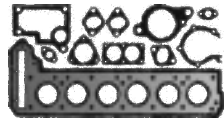

9HP (DV6D)/(DV6DTEd)
9HR (DV6C)

4 Cyl. 1560 ccm
Cyl. 75,0 Ø

Berlingo HDI

11/2009 →

C3 Aircross HDI

10/2017 →

C3 HDI

11/2009 →

C3 Picasso HDI

05/2010 →

C4 Cactus HDI

09/2014 →

C4 HDI

11/2009 →

C4 Picasso HDI

09/2010 →

C5 HDI

07/2010 →

C-Elysee HDI

11/2012 →

DS 3 HDI

11/2009 → 07/2015

DS 4 HDI

04/2011 → 07/2015

DS 5 HDI

11/2011 → 07/2015

S⊕* **726.090**



ES⊕ **995.620**



ES⊕ **570.920**

incl. 284.680
→04/2010



ES⊕ **570.910**

incl. 374.940
04/2010 →



CS* **449.590**

OKS **027.170**

1104.36



OKS **747.080**

718.311

0209.JN

1,25 mm $\frac{\pm}{\mp}$ 76,3 Ø
2 ▽

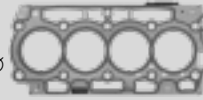

718.321

0209.JP

1,30 mm $\frac{\pm}{\mp}$ 76,3 Ø
3 ▽

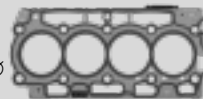

718.331

0209.JQ

1,35 mm $\frac{\pm}{\mp}$ 76,3 Ø
1 ▽



718.341

0209.JR

1,40 mm $\frac{\pm}{\mp}$ 76,3 Ø
4 ▽



718.351

0209.JS

1,45 mm $\frac{\pm}{\mp}$ 76,3 Ø
5 ▽

ZKS 330.390

0204.A4 (10x)













M 11x1,5x147



453.420

0249.G2



			<p>a) </p> <p>b) </p>	<p>K: </p> <p>N: </p>	
<p>VAS 261.330 FPM 027.750 0956.50 FPM 8x</p>	<p>284.680 0349.N5 →04/2010</p>  <p>374.940 0349.N9 04/2010→</p> 	<p>341.080 0382.QW</p> 	<p>a) 036.164 Dirko HT / EU</p> <p>a) 510.031 Dirko HT / USA/CDN/MEX</p> <p>a) 527.291 Dirko HT / RU</p> <p>a) 648.661 Dirko HT / BR</p> <p>b) 877.930 incl. 108.502 M 10x1,25x13</p> <p>b) 108.502 0313.40 CU A 10x21x2,1</p>	<p>K:← 026.750 0127.42 ASW RD PTFE/FPM 40x55x6,4</p> <p>K:→ 026.790 0127.43 ASW LD PTFE/FPM 85x105x8,8</p> <p>N:← 026.740 0807.30 ASW RD PTFE/ACM 27x47x7</p>	<p>TLS 430.160</p> 

CITROËN

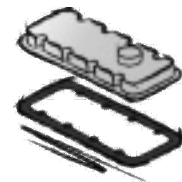
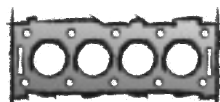
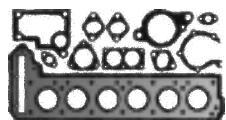

9HS (DV6TED4BU)
9HT (DV6BTED4)/
(DV6BUTED4)
9HU (DV6UTED4)
9HV (DV6TED4B)/
(DV6TED4BU)
9HW (DV6BTED4)
9HX (DV6ATED4)/
(DV6AUTED4)
9HY (DV6TED4)
9HZ (DV6TED4)
DV6B

4 Cyl. **1560 ccm**
Cyl. 75,0 Ø

Berlingo HDI
07/2005 →

C2 HDI
09/2005 → 12/2009

C3 HDI
09/2005 →

C3 Picasso HDI
02/2009 →

C4 HDI
11/2004 → 07/2011

C4 Picasso HDI
10/2006 → 08/2013

C5 HDI
09/2004 →

Jumpy HDI
01/2007 → 03/2016

Xsara Picasso HDI
05/2004 → 12/2011

S⊕* **456.780**



S⊕* **726.090**



ES⊕ **569.410**



CS* **030.780**

OKS **027.170**

1104.36

OKS **747.080**



569.812

0209.CA

0,533 mm



→ 0,634 mm

1,25 mm $\frac{1}{16}$ 76 Ø

2 ⊗

2 ∇

569.822

0209.CC

0,635 mm



→ 0,684 mm

1,30 mm $\frac{1}{16}$ 76 Ø

3 ⊗

3 ∇

569.802

0209.CE

0,685 mm



→ 0,734 mm

1,35 mm $\frac{1}{16}$ 76 Ø

1 ⊗

1 ∇

569.832

0209.CF

0,735 mm



→ 0,784 mm

1,40 mm $\frac{1}{16}$ 76 Ø

4 ⊗

4 ∇

569.842

0209.CG

0,785 mm



→ 0,886 mm

1,45 mm $\frac{1}{16}$ 76 Ø

5 ⊗

5 ∇

ZKS 330.390

0204.A4 (10x)









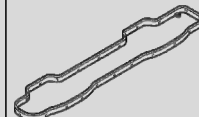



M 11x1,5x147

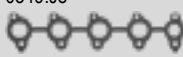

375.510

0249.C2



			<p>a) </p> <p>b) </p>	<p>K: </p> <p>N: </p>	
<p>262.650 0956.51 FPM 16x</p>	<p>761.041 0349.J8</p> 	<p>AAS 429.040</p>  <p>389.041 0348.R5 4x</p>  <p>389.121 0348.R4 4x</p> 	<p>a) 036.164 Dirko HT / EU</p> <p>a) 510.031 Dirko HT / USA/CDN/MEX</p> <p>a) 527.291 Dirko HT / RU</p> <p>a) 648.661 Dirko HT / BR</p> <p>b) 877.930 incl. 108.502 M 10x1,25x13</p> <p>b) 108.502 0313.40 CU A 10x21x2,1</p>	<p>K:← 026.750 0127.42 ASW RD PTFE/FPM 40x55x6,4</p> <p>K:→ 026.790 0127.43 ASW LD PTFE/FPM 85x105x8,8</p> <p>N:← 026.740 0807.30 ASW RD PTFE/ACM 27x47x7</p>	<p>TLS 714.600</p> 

CITROËN

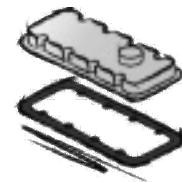
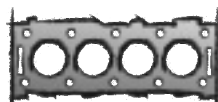
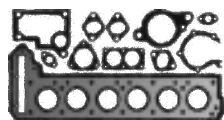

BHS (DV6FDU)
BHT (DV6FC)
BHU (DV6FC)
BHV (DV6FDU)
BHW (DV6FE)
BHX (DV6FC)/(DV6FCU)
BHY (DV6FD)
BHZ (DV6FC)

4 Cyl. **1560 ccm**
 Cyl. 75,0 Ø

Berlingo HDI

04/2008 →

C3 Aircross HDI

06/2017 →

C3 HDI

07/2014 →

C3 Picasso HDI

01/2015 →

C4 Cactus HDI

09/2014 →

C4 HDI

07/2014 →

C4 Picasso HDI

02/2013 →

C4 Spacetourer HDI

04/2018 →

C-Elysee HDI

11/2014 →

DS 3 HDI

10/2013 → 07/2015

DS 4 HDI

07/2014 → 07/2015

DS 5 HDI

11/2013 → 07/2015

Grand C4 HDI



04/2018 →

Jumpy HDI

04/2016 →

Spacetourer HDI

04/2016 →

S⊕* **928.950**

 ES⊕ **795.100**

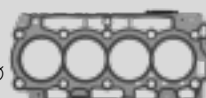
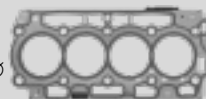
 CS* **632.450**
 OKS **632.430**
 98 043 384 80

718.311
 0209.JN
 1,25 mm $\frac{1}{2}$ 76,3 Ø
 2 ▽
718.321
 0209.JP
 1,30 mm $\frac{1}{2}$ 76,3 Ø
 3 ▽
718.331
 0209.JQ
 1,35 mm $\frac{1}{2}$ 76,3 Ø
 1 ▽
718.341
 0209.JR
 1,40 mm $\frac{1}{2}$ 76,3 Ø
 4 ▽
718.351
 0209.JS
 1,45 mm $\frac{1}{2}$ 76,3 Ø
 5 ▽

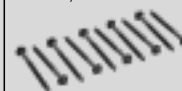

ZKS 330.390
 0204.A4 (10x)
 M 11x1,5x147



453.420
 0249.G2



171A-D
180Z
180A (XU5J)
182A
B1A (XU51C/K)
B1E (XU51C)
B6D
B6E
BAY (XU5CP)
BAZ (XU5CP)
BDY (XU5M)
BDZ (XU5M)
XU52C

4 Cyl. **1580 ccm**
 Cyl. 83,0 Ø

BX

10/1982 → 12/1994

Visa

01/1985 → 03/1991

ZX

03/1991 → 10/1997

S⊕* **590.917**
 0197.H7
 +0209.E1
 S⊕* **945.470**
 497391P
 ES⊕ **529.250**

 CS* **984.427**

563.147
 0209.E1
 1,27 mm $\frac{1}{2}$ 84,5 Ø
436.651
 0209.L3
 1,48 mm $\frac{1}{2}$ 84,5 Ø



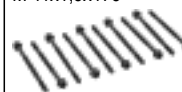























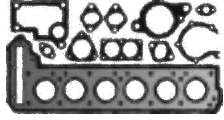
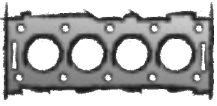







ZKS 758.280
 0204.57 (10x)
 M 11x1,5x175

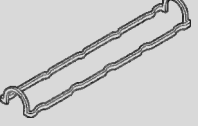

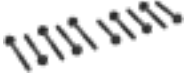













590.932
 0249.48

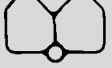

			<p>a) </p> <p>b) </p>	<p>K: </p> <p>N: </p>	
<p>VAS 261.330 FPM 027.750 0956.50 FPM 8x</p>	<p>374.940 0349.N9</p> 	<p>341.080 0382.QW</p> 	<p>a) 036.164 Dirko HT / EU</p> <p>a) 510.031 Dirko HT / USA/CDN/MEX</p> <p>a) 527.291 Dirko HT / RU</p> <p>a) 648.661 Dirko HT / BR</p> <p>b) 877.930 incl. 108.502 M 10x1,25x13</p> <p>b) 108.502 0313.40 CU A 10x21x2,1</p>	<p>K:← 026.750 0127.42 ASW RD PTFE/FPM 40x55x6,4</p> <p>K:→ 026.790 0127.43 ASW LD PTFE/FPM 85x105x8,8</p> <p>N:← 026.740 0807.30 ASW RD PTFE/ACM 27x47x7</p>	<p>TLS 634.760</p>
<p>VAS 294.250 FPM 294.110 0956.22 FPM 8x</p>	<p>590.959 0349.70 4x</p> 	<p>693.660 0348.91</p> 	<p>a) 590.984 0304.34</p>  <p>b) 813.052 0164.30 CU C 16x22x2</p>	<p>K:← 508.233 0326.22 ASW RD FPM/ACM 42x62x7</p> <p>K:→ 508.209 0127.28 ASW LD FPM/ACM 90x110x7</p> <p>N:← 505.366 0236.44 ASW RD FPM/ACM 36x50x7</p>	

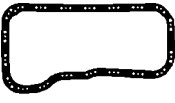
CITROËN  Das Original				
BFZ (XU5JP) 4 Cyl. 1580 ccm Cyl. 83,0 Ø Xantia 03/1993 → 03/2001 ZX 03/1991 → 10/1997	ES⊕ 023.401 0197.G4 +209.E1  PLASTIC ES⊕ 745.631  PLASTIC  CS* 984.427	563.147 0209.E1 1,27 mm $\frac{1}{2}$ 84,5 Ø  436.651 0209.L3 1,48 mm $\frac{1}{2}$ 84,5 Ø 	ZKS 758.280 0204.57 (10x) M 11x1,5x175 →03/1997  ZKS 758.290 0204.89 (10x) M 11x1,5x168 04/1997→ 	023.711 0249.71  PLASTIC 
1580 SPI 220 A2.000 4 Cyl. 1581 ccm Cyl. 86,4 Ø Jumpy 10/1995 → 08/2000		144.150 0209.P9 1,65 mm $\frac{1}{2}$ 87 Ø 	ZKS 760.870 M 10x1,25x84/99 	462.713 0249.83 ↑  435.361 0249.84 ↓ 
EC5 NFP (EC5) 4 Cyl. 1587 ccm Cyl. 78,5 Ø Berlingo 10/2018 → C3 01/2012 → C3 Aircross 07/2012 → C3 Picasso 07/2011 → C4 01/2013 → C4 Aircross 06/2017 → 03/2021 C4 Cactus 01/2019 → C-Elysee 11/2012 →	ES⊕ 699.310 CS* 699.320	384.420 0209.1E 0,62 mm $\frac{1}{2}$ 79,9 Ø 	ZKS 431.440 0204.C4 (10x) M 10x1,5x117 	240.810 0249.C6 2x 

			<p>a) </p> <p>b) </p>	<p>K: </p> <p>N: </p>	
<p>VAS 294.250 FPM</p> <p>294.110 0956.22 FPM 8x</p>	<p>160.720 1723.63</p> 	<p>023.540 0348.E6 2x</p>  <p>023.680 0348.F6 2x</p> 	<p>a) 590.984 0304.34</p>  <p>b) 813.052 0164.30 CU C 16x22x2</p>	<p>K:← 508.233 0326.22 ASW RD FPM/ACM 42x62x7</p> <p>K:→ 508.209 0127.28 ASW LD FPM/ACM 90x110x7</p> <p>N:← 505.366 0236.44 ASW RD FPM/ACM 36x50x7</p>	
<p>VAS 294.250 FPM</p> <p>294.110 0956.22 FPM 8x</p>		<p>435.372</p> 	<p>a) 435.410 0304.49</p>  <p>b) 587.100 M 22x1,5x13</p>	<p>K:← 440.760 0514.79 AW/B RD FPM 40x56x7</p> <p>K:→ 440.780 0514.78 AW/BS LD ACM 64x80x8</p> <p>N:← 440.750 0803.09 AW/BS RD FPM 30x52x7</p>	
<p>VAS 424.800 FPM</p> <p>403.730 0956.40 0956.38 FPM 16x</p>	<p>215.451 0349.L3</p> 	<p>258.780 0348.Q5 4x</p> 	<p>a) 036.164 Dirko HT / EU</p> <p>a) 510.031 Dirko HT / USA/CDN/MEX</p> <p>a) 527.291 Dirko HT / RU</p> <p>a) 648.661 Dirko HT / BR</p> <p>b) 434.941 M 16x1,5x12 incl. 813.052</p> <p>b) 834.823 0164.88 NBR A 16,7x24x1,5 FE/NBR</p>	<p>K:← 369.530 0514.A3 ASW RD PTFE/ACM 42x66x7</p> <p>K:→ 369.470 0514.A2 ASW LD PTFE/ACM 85x105x8</p> <p>N:← 135.140 0807.24 ASW RD FPM 38x50x6</p> <p>N:← 332.670 0236.65 ASW RD FPM 39x50x7</p>	

CITROËN

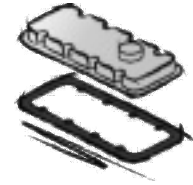
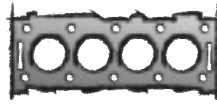
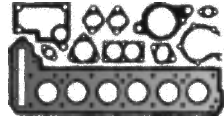

N6A (TU5JP4)
NFU (TU5JP4)
 4 Cyl. **1587 ccm**
 Cyl. 78,5 Ø

- Berlingo**
10/2000 →
- C2**
07/2003 → 09/2017
- C3**
02/2002 →
- C3 Aircross**
08/2010 →
- C3 Picasso**
04/2011 → 12/2016
- C3 Pluriel**
05/2003 →
- C4**
11/2004 →
- C4 Aircross**
07/2012 → 03/2021
- Xsara**
09/2000 → 08/2005
- Xsara Picasso**
06/2005 → 06/2012

ES⊕ **261.420**
→Mot. 2336722
 ES⊕ **430.830**
Mot. 2336723→
 C4
→10/2007
 ES⊕ **430.840**
C4
10/2007→

 CS* **431.610**

384.420
0209.1E
0,62 mm $\frac{1}{16}$ 79,9 Ø



ZKS 431.440
0204.C4 (10x)
M 10x1,5x117



177.110
0249.A9
→Mot. 2336722
2x



240.810
0249.C6
Mot. 2336723→
2x

C4
→10/2007



240.820
0249.G0
C4
10/2007→
2x

NFR (TU5JP4B)
 4 Cyl. **1587 ccm**
 Cyl. 78,5 Ø

- Berlingo**
04/2008 →

ES⊕ **430.830**
CS* **431.610**

384.420
0209.1E
0,62 mm $\frac{1}{16}$ 79,9 Ø

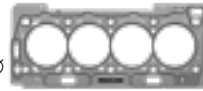

ZKS 431.440
0204.C4 (10x)
M 10x1,5x117



240.810
0249.C6
2x



NFS (TU5JP4S)
 4 Cyl. **1587 ccm**
 Cyl. 78,5 Ø

- C2**
10/2004 → 12/2009















CS* **431.610**

384.420
0209.1E
0,62 mm $\frac{1}{16}$ 79,9 Ø

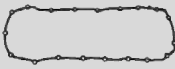

ZKS 431.440
0204.C4 (10x)
M 10x1,5x117



			<p>a) </p> <p>b) </p>	<p>K: </p> <p>N: </p>	
<p>VAS 424.800 FPM 403.730 0956.40 0956.38 FPM 16x</p>	<p>215.451 0349.L3 </p>	<p>258.780 0348.Q5 4x </p>	<p>a) 331.690 0304.55 →02/2004 </p> <p>a) 036.164 Dirko HT / EU 02/2004→</p> <p>a) 510.031 Dirko HT / USA/CDN/MEX 02/2004→</p> <p>a) 527.291 Dirko HT / RU 02/2004→</p> <p>a) 648.661 Dirko HT / BR 02/2004→</p> <p>b) 434.941 M 16x1,5x12 incl. 813.052</p> <p>b) 834.823 0164.88 NBR A 16,7x24x1,5 FE/NBR</p>	<p>K:← 369.530 0514.A3 ASW RD PTFE/ACM 42x66x7</p> <p>K:← 505.740 0514.72 ASW RD FPM/ACM 42x66x6</p> <p>K:→ 135.110 0514.74 ASW LD FPM/ACM 85x105x9</p> <p>K:→ 369.470 0514.A2 ASW LD PTFE/ACM 85x105x8</p> <p>N:← 135.140 0807.24 ASW RD FPM 38x50x6 2x</p>	
<p>VAS 424.800 FPM 403.730 0956.40 0956.38 FPM 16x</p>	<p>215.451 0349.L3 </p>	<p>258.780 0348.Q5 4x </p>	<p>a) 036.164 Dirko HT / EU</p> <p>a) 510.031 Dirko HT / USA/CDN/MEX</p> <p>a) 527.291 Dirko HT / RU</p> <p>a) 648.661 Dirko HT / BR</p> <p>b) 434.941 M 16x1,5x12 incl. 813.052</p> <p>b) 834.823 0164.88 NBR A 16,7x24x1,5 FE/NBR</p>	<p>K:← 369.530 0514.A3 ASW RD PTFE/ACM 42x66x7</p> <p>K:← 505.740 0514.72 ASW RD FPM/ACM 42x66x6</p> <p>K:→ 135.110 0514.74 ASW LD FPM/ACM 85x105x9</p> <p>K:→ 369.470 0514.A2 ASW LD PTFE/ACM 85x105x8</p> <p>N:← 135.140 0807.24 ASW RD FPM 38x50x6 2x</p>	
<p>VAS 424.800 FPM 403.730 0956.40 0956.38 FPM 16x</p>	<p>215.451 0349.L3 </p>		<p>a) 036.164 Dirko HT / EU</p> <p>a) 510.031 Dirko HT / USA/CDN/MEX</p> <p>a) 527.291 Dirko HT / RU</p> <p>a) 648.661 Dirko HT / BR</p> <p>b) 434.941 M 16x1,5x12 incl. 813.052</p> <p>b) 834.823 0164.88 NBR A 16,7x24x1,5 FE/NBR</p>	<p>K:← 369.530 0514.A3 ASW RD PTFE/ACM 42x66x7</p> <p>K:← 505.740 0514.72 ASW RD FPM/ACM 42x66x6</p> <p>K:→ 135.110 0514.74 ASW LD FPM/ACM 85x105x9</p> <p>K:→ 369.470 0514.A2 ASW LD PTFE/ACM 85x105x8</p> <p>N:← 135.140 0807.24 ASW RD FPM 38x50x6 2x</p>	

CITROËN

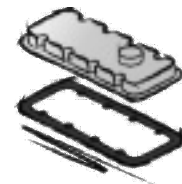
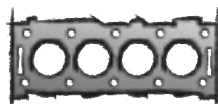
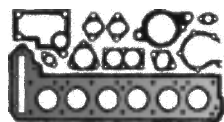

NFT (TU5JP)
NFV (TU5JP)

4 Cyl. **1587 ccm**
Cyl. 78,5 Ø

Saxo

09/2000 → 04/2004

Xsara Picasso

12/1999 → 12/2010

ES⊕ **505.210**
CS* **218.850**

218.890
0209.W8
1,37 mm $\frac{1}{2}$ 79,7 Ø



135.280
0209.W9
1,57 mm $\frac{1}{2}$ 79,7 Ø



ZKS 758.300
0204.83 (10x)
M 10x1,5x175



776.416
0249.54



NFX (TU5JP4)

4 Cyl. **1587 ccm**
Cyl. 78,5 Ø

C3 Picasso

04/2011 → 06/2013

C4 Aircross

08/2010 → 06/2012

Saxo

02/1996 → 04/2004

ES⊕ **505.120**
ES⊕ **730.830**



505.341
0209.Z0
1,37 mm $\frac{1}{2}$ 79,7 Ø
2 ▽



505.371
0209.W3
1,57 mm $\frac{1}{2}$ 79,7 Ø
3 ▽



505.391
0209.Z1
1,77 mm $\frac{1}{2}$ 79,7 Ø
4 ▽

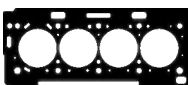

ZKS 431.440
0204.C4 (10x)
M 10x1,5x117

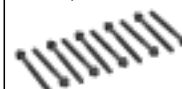

036.164

Dirko HT / EU

510.031

Dirko HT / USA/CDN/MEX

527.291

Dirko HT / RU

648.661

Dirko HT / BR

NFZ (TU5JP)

4 Cyl. **1587 ccm**
Cyl. 78,5 Ø

Saxo

02/1996 → 06/2003

Xsara

04/1997 → 09/2000

Xsara Picasso

12/1999 → 08/2005

ES⊕ **375.200**
→05/1998

ES⊕ **375.300**
D3 / L3
06/1998→

CS* **218.850**

218.890
0209.W8
1,37 mm $\frac{1}{2}$ 79,7 Ø



135.280
0209.W9
1,57 mm $\frac{1}{2}$ 79,7 Ø











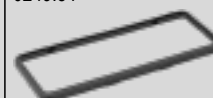







ZKS 758.300
0204.83 (10x)
M 10x1,5x175











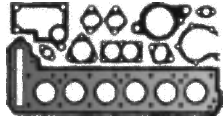
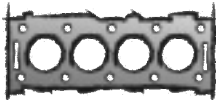

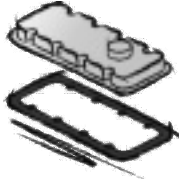
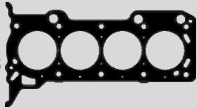



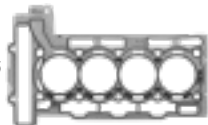
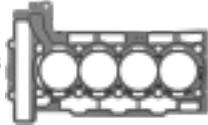





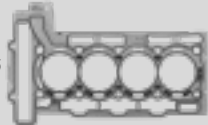
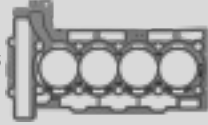











776.416

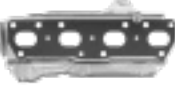









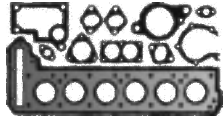
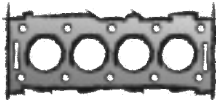

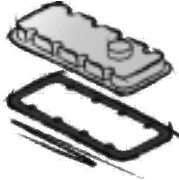

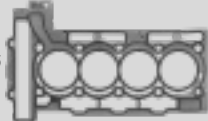
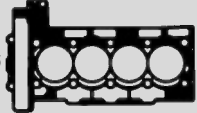
0249.54

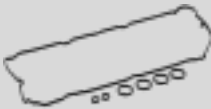

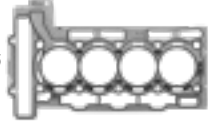
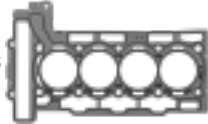



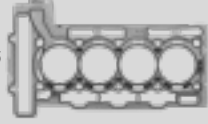
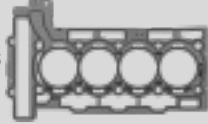

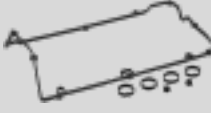





















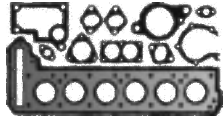
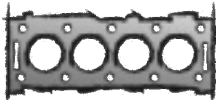

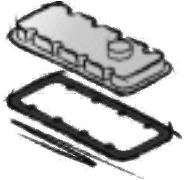
			<p>a) </p> <p>b) </p>	<p>K: </p> <p>N: </p>	
<p>VAS 825.042 FPM 701.289 0956.28 FPM 8x</p>	<p>258.311 0349.K1 </p>	<p>331.810 0348.P3 4x </p>	<p>a) 773.740 </p> <p>b) 434.941 M 16x1,5x12 incl. 813.052 b) 834.823 0164.88 NBR A 16,7x24x1,5 FE/NBR</p>	<p>K:← 369.530 0514.A3 ASW RD PTFE/ACM 42x66x7 K:← 505.740 0514.72 ASW RD FPM/ACM 42x66x6 K:→ 135.110 0514.74 ASW LD FPM/ACM 85x105x9 K:→ 315.494 0514.40 ASW LD FPM/ACM 85x105x12 K:→ 369.470 0514.A2 ASW LD PTFE/ACM 85x105x8 N:← 505.366 0236.44 ASW RD FPM/ACM 36x50x7</p>	
<p>VAS 424.800 FPM 403.730 0956.40 0956.38 FPM 16x</p>		<p>545.930 0348.L0 4x </p>	<p>a) 036.164 Dirko HT / EU a) 510.031 Dirko HT / USA/CDN/MEX a) 527.291 Dirko HT / RU a) 648.661 Dirko HT / BR b) 434.941 M 16x1,5x12 incl. 813.052 b) 834.823 0164.88 NBR A 16,7x24x1,5 FE/NBR</p>	<p>K:← 369.530 0514.A3 ASW RD PTFE/ACM 42x66x7 K:← 505.740 0514.72 ASW RD FPM/ACM 42x66x6 K:→ 135.110 0514.74 ASW LD FPM/ACM 85x105x9 K:→ 315.494 0514.40 ASW LD FPM/ACM 85x105x12 K:→ 369.470 0514.A2 ASW LD PTFE/ACM 85x105x8 N:← 135.140 0807.24 ASW RD FPM 38x50x6 2x</p>	
<p>VAS 825.042 FPM 701.289 0956.28 FPM 8x</p>	<p>388.151 0349.A6 2x </p>	<p>331.640 0348.E5 4x →05/1998 331.810 0348.P3 4x 06/1998→ </p>	<p>a) 773.740 </p> <p>b) 434.941 M 16x1,5x12 incl. 813.052 b) 834.823 0164.88 NBR A 16,7x24x1,5 FE/NBR</p>	<p>K:← 369.530 0514.A3 ASW RD PTFE/ACM 42x66x7 K:← 505.740 0514.72 ASW RD FPM/ACM 42x66x6 K:→ 135.110 0514.74 ASW LD FPM/ACM 85x105x9 K:→ 315.494 0514.40 ASW LD FPM/ACM 85x105x12 K:→ 369.470 0514.A2 ASW LD PTFE/ACM 85x105x8 N:← 505.366 0236.44 ASW RD FPM/ACM 36x50x7</p>	

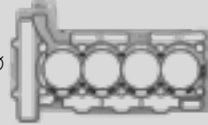
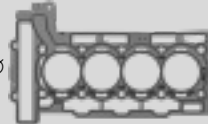

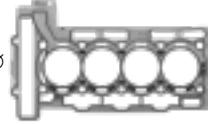
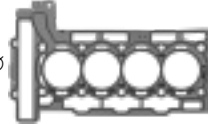





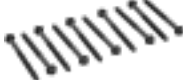
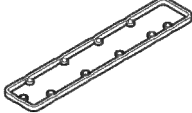
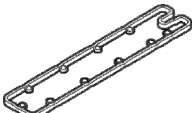











<p>CITROËN</p> 				
<p>4A92 NKZ (4A92)</p> <p>4 Cyl. 1590 ccm Cyl. 75,0 Ø</p> <p>C4 Aircross 04/2012 →</p>	<p>S⊕* 455.270</p>	<p>457.160 16 075 925 80 76 Ø</p> 	<p>ZKS 728.130 16 075 990 80 M 9x1,25x145</p> 	<p>172.440 16 075 921 80</p> 
<p>5FA (EP6CDT)/(EP6CDTD)</p> <p>4 Cyl. 1598 ccm Cyl. 77,0 Ø</p>	<p>CS* 376.330 OKS 375.640</p> 	<p>729.040 ● 0209.ER 0,90 mm $\frac{\pm}{\pm}$ 78 Ø</p>  <p>729.041 0,90 mm $\frac{\pm}{\pm}$ 78 Ø</p> <p>295.750 ● 0209.HP 1,20 mm $\frac{\pm}{\pm}$ 78 Ø</p>  <p>295.751 1,20 mm $\frac{\pm}{\pm}$ 78 Ø</p>	<p>ZKS 426.830 0204.C1 (10x) M 10x1,5x150,5 M8x1,25/35/95,3</p> 	<p>ZKHS 384.680 0249.E7 +0249.E6 (2x)</p> 
<p>5F4 (EP6DT) 5FC (EP6CDTM) 5FD (EP6DTS) 5FE (EP6CDTMD) 5FF (EP6DTS) 5FM (EP6CDTM)/(EP6DT) 5FN (EP6CDT)/(EP6DT) 5FR (EP6DT) 5FT (EP6DT) 5FV (EP6CDT) 5FX (EP6DT) 5FY (EP6CDTX)/(EP6DT)/(EP6DTS)</p> <p>4 Cyl. 1598 ccm Cyl. 77,0 Ø</p> <p>C4 06/2008 →</p> <p>C4 Picasso 07/2008 →</p> <p>C5 04/2009 →</p> <p>DS 3 01/2010 → 07/2015</p> <p>DS 4 04/2011 → 07/2015</p> <p>DS 5 11/2011 → 07/2015</p>	<p>ES⊕ 335.300</p>  <p>ES⊕ 794.920</p>  <p>CS* 376.330 OKS 375.640</p> 	<p>729.040 ● 0209.ER 0,90 mm $\frac{\pm}{\pm}$ 78 Ø</p>  <p>729.041 0,90 mm $\frac{\pm}{\pm}$ 78 Ø</p> <p>295.750 ● 0209.HP 1,20 mm $\frac{\pm}{\pm}$ 78 Ø</p>  <p>295.751 1,20 mm $\frac{\pm}{\pm}$ 78 Ø</p>	<p>ZKS 426.830 0204.C1 (10x) M 10x1,5x150,5 M8x1,25/35/95,3</p> 	<p>ZKHS 384.680 0249.E7 +0249.E6 (2x)</p> 

			<p>a) </p> <p>b) </p>	<p>K: </p> <p>N: </p>	
<p>904.900 16 081 662 80 FPM 16x</p>	<p>455.230 16 075 911 80</p> 	<p>AAS 386.430</p>	<p>a) 036.164 Dirko HT / EU</p> <p>a) 510.031 Dirko HT / USA/CDN/MEX</p> <p>a) 527.291 Dirko HT / RU</p> <p>a) 648.661 Dirko HT / BR</p>	<p>K:← 901.630 16 075 932 80 AS RD FPM 29x48x7</p> <p>K:→ 232.480 16 078 540 80 SP LD FPM 84,5</p>	
<p>VAS 747.210 0956.60 FPM</p>	<p>743.560 96 781 882 80</p> 	<p>AAS 893.650 0348.S9</p>  <p>893.600 4x</p> 	<p>a) 036.164 Dirko HT / EU</p> <p>a) 510.031 Dirko HT / USA/CDN/MEX</p> <p>a) 527.291 Dirko HT / RU</p> <p>a) 648.661 Dirko HT / BR</p> <p>b) 523.470 incl. 813.052 0311.39 M 16x1,5x16</p> <p>b) 813.052 0164.30 CU C 16x22x2</p>	<p>K:← 004.450 0514.C8 ASW RD PTFE/ACM 61x75x8</p> <p>K:→ 369.470 0514.A2 ASW LD PTFE/ACM 85x105x8</p>	<p>TLS 376.340</p> 
<p>VAS 747.210 0956.60 FPM</p>	<p>354.802 1723.AZ</p> 	<p>AAS 893.650 0348.S9</p>  <p>893.600 4x</p> 	<p>a) 036.164 Dirko HT / EU</p> <p>a) 510.031 Dirko HT / USA/CDN/MEX</p> <p>a) 527.291 Dirko HT / RU</p> <p>a) 648.661 Dirko HT / BR</p> <p>b) 523.470 incl. 813.052 0311.39 M 16x1,5x16</p> <p>b) 813.052 0164.30 CU C 16x22x2</p>	<p>K:← 004.450 0514.C8 ASW RD PTFE/ACM 61x75x8</p> <p>K:→ 369.470 0514.A2 ASW LD PTFE/ACM 85x105x8</p>	<p>TLS 376.340</p> 

<p>CITROËN</p> 				
<p>5FK (EP6CB) 5FP (EP6) 5FS (EP6C) 5FW (EP6)</p> <p>4 Cyl. 1598 ccm Cyl. 77,0 Ø</p> <p>Berlingo 11/2009 →</p> <p>C3 11/2009 →</p> <p>C3 Picasso 02/2009 →</p> <p>C4 07/2008 →</p> <p>C4 Picasso 07/2008 →</p> <p>C5 07/2010 →</p> <p>DS 3 04/2010 → 07/2015</p> <p>DS 4 04/2011 → 07/2015</p>	<p>ES⊕ 898.110</p>  <p>CS* 390.440</p>	<p>729.050 0209.EW 0,90 mm $\frac{\pm}{\text{mm}}$ 78 Ø</p>  <p>295.930 0209.JA 1,20 mm $\frac{\pm}{\text{mm}}$ 78 Ø</p> 	<p>ZKS 426.830 0204.C1 (10x) M 10x1,5x150,5 M8x1,25/35/95,3</p> 	<p>ZKHS 898.100 0249.F4</p> 
<p>5FU (EP6CDTX)/(EP6DTX)</p> <p>4 Cyl. 1598 ccm Cyl. 77,0 Ø</p> <p>DS 4 04/2011 → 07/2015</p> <p>DS 5 11/2011 → 07/2015</p>	<p>CS* 376.330 OKS 375.640</p> 	<p>729.040 ● 0209.ER 0,90 mm $\frac{\pm}{\text{mm}}$ 78 Ø</p>  <p>729.041 0,90 mm $\frac{\pm}{\text{mm}}$ 78 Ø</p> <p>295.750 ● 0209.HP 1,20 mm $\frac{\pm}{\text{mm}}$ 78 Ø</p>  <p>295.751 1,20 mm $\frac{\pm}{\text{mm}}$ 78 Ø</p>	<p>ZKS 426.830 0204.C1 (10x) M 10x1,5x150,5 M8x1,25/35/95,3</p> 	<p>ZKHS 298.220 0249.G9</p> 
<p>5GF (EP6FADTXD)</p> <p>4 Cyl. 1598 ccm Cyl. 77,0 Ø</p> <p>C5 Aircross 11/2018 →</p> <p>Grand C4 04/2018 →</p>	<p>CS* 376.330 OKS 375.640</p> 	<p>729.040 ● 0209.ER 0,90 mm $\frac{\pm}{\text{mm}}$ 78 Ø</p>  <p>729.041 0,90 mm $\frac{\pm}{\text{mm}}$ 78 Ø</p> <p>295.750 ● 0209.HP 1,20 mm $\frac{\pm}{\text{mm}}$ 78 Ø</p>  <p>295.751 1,20 mm $\frac{\pm}{\text{mm}}$ 78 Ø</p>	<p>ZKS 426.830 0204.C1 (10x) M 10x1,5x150,5 M8x1,25/35/95,3</p> 	<p>ZKHS 298.220 0249.G9</p> 









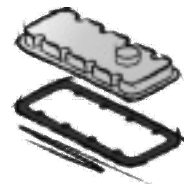
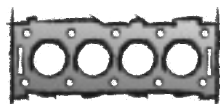
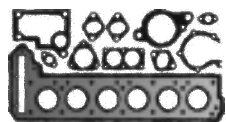







			<p>a) </p> <p>b) </p>	<p>K: </p> <p>N: </p>	
<p>VAS 747.210 0956.60 FPM</p>	<p>174.981 1723.CH</p> 	<p>895.440 0348.T4 4x</p> 	<p>a) 036.164 Dirko HT / EU</p> <p>a) 510.031 Dirko HT / USA/CDN/MEX</p> <p>a) 527.291 Dirko HT / RU</p> <p>a) 648.661 Dirko HT / BR</p> <p>b) 523.470 incl. 813.052 0311.39 M 16x1,5x16</p> <p>b) 813.052 0164.30 CU C 16x22x2</p>	<p>K:← 004.450 0514.C8 ASW RD PTFE/ACM 61x75x8</p> <p>K:→ 369.470 0514.A2 ASW LD PTFE/ACM 85x105x8</p>	
<p>VAS 747.210 0956.60 FPM</p>	<p>354.802 1723.AZ</p> 	<p>AAS 893.650 0348.S9</p>  <p>893.600 4x</p> 	<p>a) 036.164 Dirko HT / EU</p> <p>a) 510.031 Dirko HT / USA/CDN/MEX</p> <p>a) 527.291 Dirko HT / RU</p> <p>a) 648.661 Dirko HT / BR</p> <p>b) 523.470 incl. 813.052 0311.39 M 16x1,5x16</p> <p>b) 813.052 0164.30 CU C 16x22x2</p>	<p>K:← 004.450 0514.C8 ASW RD PTFE/ACM 61x75x8</p> <p>K:→ 369.470 0514.A2 ASW LD PTFE/ACM 85x105x8</p>	<p>TLS 376.340</p> 
<p>VAS 747.210 0956.60 FPM</p>		<p>AAS 893.650 0348.S9</p>  <p>893.600 4x</p> 	<p>a) 036.164 Dirko HT / EU</p> <p>a) 510.031 Dirko HT / USA/CDN/MEX</p> <p>a) 527.291 Dirko HT / RU</p> <p>a) 648.661 Dirko HT / BR</p> <p>b) 523.470 incl. 813.052 0311.39 M 16x1,5x16</p> <p>b) 813.052 0164.30 CU C 16x22x2</p>	<p>K:← 004.450 0514.C8 ASW RD PTFE/ACM 61x75x8</p> <p>K:→ 369.470 0514.A2 ASW LD PTFE/ACM 85x105x8</p>	<p>TLS 376.340</p> 

<p>CITROËN</p> 				
<p>5GX (EP6FDTMD) 5GY (EP6FDTM)</p> <p>4 Cyl. 1598 ccm Cyl. 77,0 Ø</p> <p>C4 08/2013 →</p> <p>C4 Cactus 01/2019 →</p> <p>C5 Aircross 05/2019 →</p> <p>Grand C4 04/2018 →</p>	<p>CS* 376.330 OKS 375.640</p> 	<p>729.040 ● 0209.ER 0,90 mm $\frac{\pm}{\pm}$ 78 Ø</p>  <p>729.041 0,90 mm $\frac{\pm}{\pm}$ 78 Ø</p> <p>295.750 ● 0209.HP 1,20 mm $\frac{\pm}{\pm}$ 78 Ø</p>  <p>295.751 1,20 mm $\frac{\pm}{\pm}$ 78 Ø</p>	<p>ZKS 426.830 0204.C1 (10x) M 10x1,5x150,5 M8x1,25/35/95,3</p> 	<p>ZKHS 491.370 98 052 642 80</p>
<p>5GZ (EP6FDT)</p> <p>4 Cyl. 1598 ccm Cyl. 77,0 Ø</p> <p>C4 Picasso 07/2014 →</p> <p>C4 Spacetourer 04/2018 →</p> <p>DS 3 10/2014 → 07/2015</p> <p>DS 4 01/2012 → 07/2015</p> <p>DS 5 01/2012 → 07/2015</p> <p>Grand C4 04/2018 →</p>	<p>CS* 376.330 OKS 375.640</p> 	<p>729.040 ● 0209.ER 0,90 mm $\frac{\pm}{\pm}$ 78 Ø</p>  <p>729.041 0,90 mm $\frac{\pm}{\pm}$ 78 Ø</p> <p>295.750 ● 0209.HP 1,20 mm $\frac{\pm}{\pm}$ 78 Ø</p>  <p>295.751 1,20 mm $\frac{\pm}{\pm}$ 78 Ø</p>	<p>ZKS 426.830 0204.C1 (10x) M 10x1,5x150,5 M8x1,25/35/95,3</p> 	<p>ZKHS 491.370 98 052 642 80</p>
<p>6FY (EW7A)</p> <p>4 Cyl. 1749 ccm Cyl. 82,7 Ø</p> <p>C4 Picasso 10/2006 → 01/2013</p> <p>C5 09/2005 →</p>	<p>ES⊕ 687.860</p>  <p>CS* 688.000</p>	<p>655.450 0209.FR 0,70 mm $\frac{\pm}{\pm}$ 83 Ø 2 ⊗</p> 	<p>ZKS 453.490 0204.A3 (10x) M 11x1,5x127</p> 	
<p>6FZ (EW7J4)</p> <p>4 Cyl. 1749 ccm Cyl. 82,7 Ø</p> <p>C5 03/2001 →</p> <p>Xsara 08/1998 → 10/2004</p> <p>Xsara Picasso 02/2000 → 08/2005</p>	<p>ES⊕ 271.160 0197.Y1</p> <p>CS* 458.810</p>	<p>153.200 0209.QG 83 Ø</p> 	<p>ZKS 262.820 0204.A7 (10x) M 11x1,5x141</p> 	<p>331.540 0249.A4 E</p>  <p>331.550 0249.A5 A</p> 

			<p>a) </p> <p>b) </p>	<p>K: </p> <p>N: </p>	
<p>VAS 747.210 0956.60 FPM</p>	<p>743.560 96 781 882 80</p> 	<p>AAS 893.650 0348.S9</p>  <p>893.600 4x</p> 	<p>a) 036.164 Dirko HT / EU</p> <p>a) 510.031 Dirko HT / USA/CDN/MEX</p> <p>a) 527.291 Dirko HT / RU</p> <p>a) 648.661 Dirko HT / BR</p> <p>b) 523.470 incl. 813.052 0311.39 M 16x1,5x16</p> <p>b) 813.052 0164.30 CU C 16x22x2</p>	<p>K:← 004.450 0514.C8 ASW RD PTFE/ACM 61x75x8</p> <p>K:→ 369.470 0514.A2 ASW LD PTFE/ACM 85x105x8</p>	<p>TLS 376.340</p> 
<p>VAS 747.210 0956.60 FPM</p>	<p>354.802 1723.AZ</p> 	<p>AAS 893.650 0348.S9</p>  <p>893.600 4x</p> 	<p>a) 036.164 Dirko HT / EU</p> <p>a) 510.031 Dirko HT / USA/CDN/MEX</p> <p>a) 527.291 Dirko HT / RU</p> <p>a) 648.661 Dirko HT / BR</p> <p>b) 523.470 incl. 813.052 0311.39 M 16x1,5x16</p> <p>b) 813.052 0164.30 CU C 16x22x2</p>	<p>K:← 004.450 0514.C8 ASW RD PTFE/ACM 61x75x8</p> <p>K:→ 369.470 0514.A2 ASW LD PTFE/ACM 85x105x8</p>	<p>TLS 376.340</p> 
<p>VAS 155.750 FPM</p> <p>149.360 0956.45 FPM 16x</p>	<p>339.490 0349.L0</p> 	<p>365.030 0348.S4 4x</p> 	<p>a) 036.164 Dirko HT / EU</p> <p>a) 510.031 Dirko HT / USA/CDN/MEX</p> <p>a) 527.291 Dirko HT / RU</p> <p>a) 648.661 Dirko HT / BR</p> <p>b) 813.036 0313.27 CU C 14x20x2</p>	<p>K:← 026.750 0127.42 ASW RD PTFE/FPM 40x55x6,4</p> <p>K:→ 508.209 0127.28 ASW LD FPM/ACM 90x110x7</p> <p>N:← 505.366 0236.44 ASW RD FPM/ACM 36x50x7</p> <p>N: 655.190 0236.74 ASW RD PTFE/ACM 39x50x7 E</p>	
<p>VAS 155.750 FPM</p> <p>149.360 0956.45 FPM 16x</p>	<p>136.690 0349.H8</p> 	<p>216.500 0348.P1 4x</p> 	<p>a) 036.164 Dirko HT / EU</p> <p>a) 510.031 Dirko HT / USA/CDN/MEX</p> <p>a) 527.291 Dirko HT / RU</p> <p>a) 648.661 Dirko HT / BR</p> <p>b) 813.036 0313.27 CU C 14x20x2</p>	<p>K:← 076.220 0326.27 AS RD FPM 40x55x6,5</p> <p>K:→ 508.209 0127.28 ASW LD FPM/ACM 90x110x7</p> <p>N:← 505.366 0236.44 ASW RD FPM/ACM 36x50x7 2x</p>	

CITROËN







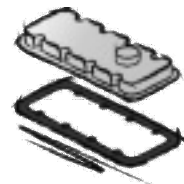
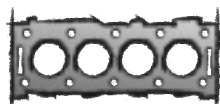
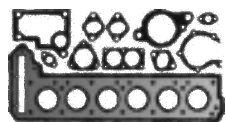





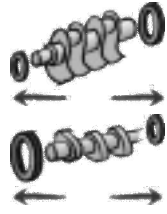

			<p>a) </p> <p>b) </p>	<p>K: </p> <p>N: </p>	
<p>VAS 294.250 FPM 294.110 0956.22 FPM 8x</p>	<p>160.720 1723.63 </p>	<p>718.240 0348.L7 4x </p>	<p>a) 036.164 Dirko HT / EU a) 510.031 Dirko HT / USA/CDN/MEX a) 527.291 Dirko HT / RU a) 648.661 Dirko HT / BR b) 813.036 0313.27 CU C 14x20x2</p>	<p>K:← 508.233 0326.22 ASW RD FPM/ACM 42x62x7 K:→ 508.209 0127.28 ASW LD FPM/ACM 90x110x7 N:← 505.366 0236.44 ASW RD FPM/ACM 36x50x7</p>	
<p>VAS 155.710 FPM →12/1996 VAS 155.720 FPM 01/1997→ →08/1998 VAS 155.750 FPM 09/1998→ 138.310 0956.34 FPM →12/1996 16x 090.970 0956.42 FPM 01/1997→ →08/1998 16x 149.360 0956.45 FPM 09/1998→ 16x</p>	<p>076.040 0349.H0 </p>	<p>176.930 0348.C8 →02/1996  181.380 0348.K6 02/1996→ 4x </p>	<p>a) 036.164 Dirko HT / EU a) 510.031 Dirko HT / USA/CDN/MEX a) 527.291 Dirko HT / RU a) 648.661 Dirko HT / BR b) 813.036 0313.27 CU C 14x20x2</p>	<p>K:← 508.233 0326.22 ASW RD FPM/ACM 42x62x7 K:→ 508.209 0127.28 ASW LD FPM/ACM 90x110x7 N:← 505.366 0236.44 ASW RD FPM/ACM 36x50x7 2x</p>	
<p>VAS 294.250 FPM 294.110 0956.22 FPM 8x</p>	<p>160.720 1723.63 </p>	<p>023.540 0348.E6 2x  023.680 0348.F6 2x </p>	<p>a) 590.984 0304.34  b) 813.036 0313.27 CU C 14x20x2</p>	<p>K:← 508.233 0326.22 ASW RD FPM/ACM 42x62x7 K:→ 508.209 0127.28 ASW LD FPM/ACM 90x110x7 N:← 505.366 0236.44 ASW RD FPM/ACM 36x50x7</p>	

CITROËN



CITROËN

			<p>a) </p> <p>b) </p>	<p>K: </p> <p>N: </p>	
<p>VAS 294.250 FPM 294.110 0956.22 FPM 8x</p>	<p>420.451 0349.78 2x</p> 	<p>AAS 734.370 0348.98 +0348.99 (2x)</p> 	<p>a) 590.984 0304.34</p>  <p>b) 813.036 0313.27 CU C 14x20x2</p> <p>b) 813.052 0164.30 CU C 16x22x2</p>	<p>K:← 508.233 0326.22 ASW RD FPM/ACM 42x62x7</p> <p>K:→ 508.209 0127.28 ASW LD FPM/ACM 90x110x7</p> <p>N:← 302.589 0236.15 A WD FPM 35x50x8</p>	
<p>VAS 294.250 FPM 294.110 0956.22 FPM 8x</p>	<p>⇒</p>	<p>919.829 0348.J0</p> 	<p>a) 590.984 0304.34</p>  <p>b) 813.052 0164.30 CU C 16x22x2</p>	<p>K:← 508.233 0326.22 ASW RD FPM/ACM 42x62x7</p> <p>K:→ 508.209 0127.28 ASW LD FPM/ACM 90x110x7</p> <p>N:← 302.589 0236.15 A WD FPM 35x50x8</p>	

CITROËN

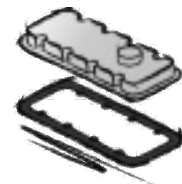
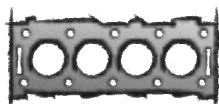
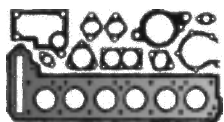

A9A (XUD7)

4 Cyl. **1769 ccm**
Cyl. 80,0 Ø

Berlingo D

07/1996 → 10/2002

Xsara D

04/1997 → 09/2000

S⊕* **581.128**
0197.H5



ES⊕ **850.271**
0197.H4



CS* **984.817**

058.671
0209.S1



0,670 mm



0,710 mm

1,40 mm $\frac{+}{-}$ 82 Ø

2 ▽

058.701



0,710 mm



0,750 mm

1,45 mm $\frac{+}{-}$ 82 Ø

3 ▽

058.841



0,750 mm



0,790 mm

1,50 mm $\frac{+}{-}$ 82 Ø

4 ▽

058.981



0,790 mm



0,830 mm

1,55 mm $\frac{+}{-}$ 82 Ø

5 ▽

ZKS **152.550**

0204.97 (10x)

M 12x1,5x123



581.305

0249.91



4N13

4 Cyl. **1798 ccm**
Cyl. 83,0 Ø











C4 Aircross HDI

04/2012 →

226.600

16 075 920 80



			<p>a) </p> <p>b) </p>	<p>K: </p> <p>N: </p>	
<p>VAS 294.250 FPM</p> <p>294.110 0956.22 FPM 8x</p>	<p>420.451 0349.78 2x</p> 		<p>a) 590.984 0304.34</p>  <p>b) 813.036 0313.27 CU C 14x20x2</p>	<p>K:← 508.233 0326.22 ASW RD FPM/ACM 42x62x7</p> <p>K:→ 508.209 0127.28 ASW LD FPM/ACM 90x110x7</p> <p>N:← 302.589 0236.15 A WD FPM 35x50x8</p>	
<p>019.140 16 081 663 80 FPM E 8x</p> <p>469.350 16 081 661 80 FPM A 8x</p>	<p>477.260 16 075 910 80</p> 	<p>474.140 16 075 917 80</p>	<p>a) 036.164 Dirko HT / EU</p> <p>a) 510.031 Dirko HT / USA/CDN/MEX</p> <p>a) 527.291 Dirko HT / RU</p> <p>a) 648.661 Dirko HT / BR</p> <p>b) 774.460 0311.37 M 14x1,5x11</p> <p>b) 394.030 0313.41 AL C 14x19x2</p>		

CITROËN

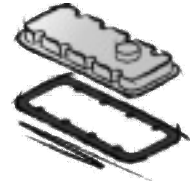
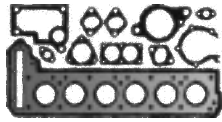

WJX (DW8B)
WJY (DW8B)
WJZ (DW8)

4 Cyl. 1868 ccm
 Cyl. 82,2 Ø

Berlingo D
 07/1998 → 12/2011

C 15
 01/2000 → 12/2005

Jumpy D
 04/1998 → 10/2006

Jumpy TD
 11/2000 → 10/2006

Xsara D
 07/1998 → 08/2005

S⊕* **718.610**
 S⊕* **896.710**



ES⊕ **219.230**
 0197.X5



CS* **851.292**

130.642
 0209.X0

0,510 mm
 →
 0,550 mm

1,26 mm $\frac{+}{-}$ 84 Ø
 1 ⊗

130.652
 0209.X1

0,550 mm
 →
 0,590 mm

1,30 mm $\frac{+}{-}$ 84 Ø
 2 ⊗

130.662
 0209.X2

0,590 mm
 →
 0,630 mm

1,34 mm $\frac{+}{-}$ 84 Ø
 3 ⊗

130.672
 0209.X3

0,630 mm
 →
 0,670 mm

1,38 mm $\frac{+}{-}$ 84 Ø
 4 ⊗

130.682
 0209.X4

0,670 mm
 →
 0,710 mm

1,42 mm $\frac{+}{-}$ 84 Ø
 5 ⊗

130.692
 0209.1C

1,46 mm $\frac{+}{-}$ 84 Ø
 2 ⊗

130.712
 0209.1F

1,50 mm $\frac{+}{-}$ 84 Ø
 1 ⊗

130.722
 0209.1G

1,54 mm $\frac{+}{-}$ 84 Ø
 2 ⊗

130.732
 0209.1H

1,58 mm $\frac{+}{-}$ 84 Ø
 3 ⊗

130.742
 0209.1J

1,62 mm $\frac{+}{-}$ 84 Ø
 4 ⊗

ZKS 152.550
 0204.97 (10x)
 M 12x1,5x123



773.650
 0249.95

↑









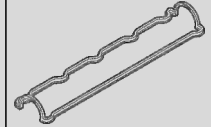





773.660
 0249.97

↓









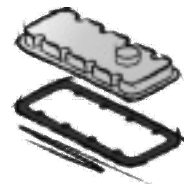
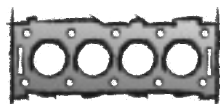
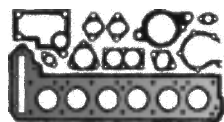





→11/1999



			<p>a) </p> <p>b) </p>	<p>K: </p> <p>N: </p>	
<p>VAS 294.250 FPM 294.110 0956.22 FPM 8x</p>	<p>773.730 0349.H7 2x</p> 	<p>773.800 0348.N2 2x</p>  <p>773.810 0348.N1</p> 	<p>a) 590.984 0304.34</p>  <p>b) 877.930 incl. 108.502 M 10x1,25x13</p> <p>b) 877.950 incl. 813.036 M 14x1,25x13</p> <p>b) 108.502 0313.40 CU A 10x21x2,1</p> <p>b) 813.036 0313.27 CU C 14x20x2</p>	<p>K:← 508.233 0326.22 ASW RD FPM/ACM 42x62x7</p> <p>K:→ 508.209 0127.28 ASW LD FPM/ACM 90x110x7</p> <p>N:← 302.589 0236.15 A WD FPM 35x50x8</p>	

CITROËN



			<p>a) </p> <p>b) </p>	<p>K: </p> <p>N: </p>	
<p>VAS 294.250 FPM 294.110 0956.22 FPM 8x</p>	<p>590.959 0349.70 4x</p> 	<p>693.660 0348.91</p> 	<p>a) 590.984 0304.34</p>  <p>b) 813.052 0164.30 CU C 16x22x2</p>	<p>K:← 508.233 0326.22 ASW RD FPM/ACM 42x62x7</p> <p>K:→ 508.209 0127.28 ASW LD FPM/ACM 90x110x7</p> <p>N:← 505.366 0236.44 ASW RD FPM/ACM 36x50x7</p>	
<p>VAS 294.250 FPM 294.110 0956.22 FPM 8x</p>	<p>420.451 0349.78 2x</p> 	<p>AAS 734.370 0348.98 +0348.99 (2x)</p> 	<p>a) 590.984 0304.34</p>  <p>b) 813.052 0164.30 CU C 16x22x2</p>	<p>K:← 508.233 0326.22 ASW RD FPM/ACM 42x62x7</p> <p>K:→ 508.209 0127.28 ASW LD FPM/ACM 90x110x7</p> <p>N:← 302.589 0236.15 A WD FPM 35x50x8</p>	
<p>VAS 825.042 FPM 2x 701.289 0956.28 FPM 16x</p>	<p>902.380 0349.E8</p>		<p>a) 590.984 0304.34</p>  <p>b) 813.052 0164.30 CU C 16x22x2</p>	<p>K:← 508.233 0326.22 ASW RD FPM/ACM 42x62x7</p> <p>K:→ 508.209 0127.28 ASW LD FPM/ACM 90x110x7</p> <p>N:← 505.366 0236.44 ASW RD FPM/ACM 36x50x7 2x</p>	

CITROËN

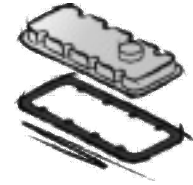
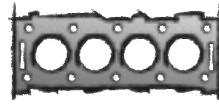
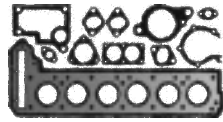

D9B
D9B (XUD9A/L)/U)
DJY (XUD9A)
DJZ (XUD9A)

4 Cyl. **1905 ccm**
 Cyl. 83,0 Ø

Berlingo D
 07/1996 → 12/2003

BX
 09/1983 → 12/1994

C 25
 07/1987 → 02/1994

Jumper D
 02/1994 → 04/2002

Jumpy D
 10/1995 → 08/1998

Xantia D
 06/1994 → 01/1998

Xsara D
 04/1997 → 09/2000

ZX D
 03/1991 → 07/1999

S⊕* **581.128**
 0197.H5



ES⊕ **850.271**
 0197.H4
 →01/1994



ES⊕ **116.580**
 01/1994→



CS* **984.817**

059.031
 0209.S5



→
 0,670 mm

1,36 mm $\frac{\pm}{\pm}$ 84 Ø
 1 ▽

059.041
 0209.S6

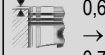

→
 0,710 mm

1,40 mm $\frac{\pm}{\pm}$ 84 Ø
 2 ▽

059.171
 0209.S7



→
 0,750 mm

1,44 mm $\frac{\pm}{\pm}$ 84 Ø
 3 ▽

059.201
 0209.S8



→
 0,790 mm

1,48 mm $\frac{\pm}{\pm}$ 84 Ø
 4 ▽

059.341
 0209.S9

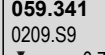

→
 0,830 mm











1,52 mm $\frac{\pm}{\pm}$ 84 Ø
 5 ▽

ZKS 152.550
 0204.97 (10x)
 M 12x1,5x123



581.305
 0249.91



			<p>a) </p> <p>b) </p>	<p>K: </p> <p>N: </p>	
<p>VAS 294.250 FPM 294.110 0956.22 FPM 8x</p>	<p>420.451 0349.78 →06/1994 2x </p> <p>773.730 0349.H7 06/1994→ 2x </p>		<p>a) 590.984 0304.34 </p> <p>b) 877.950 incl. 813.036 M 14x1,25x13</p> <p>b) 813.036 0313.27 CU C 14x20x2</p> <p>b) 813.052 0164.30 CU C 16x22x2</p>	<p>K:← 508.233 0326.22 ASW RD FPM/ACM 42x62x7</p> <p>K:→ 508.209 0127.28 ASW LD FPM/ACM 90x110x7</p> <p>N:← 302.589 0236.15 A WD FPM 35x50x8</p>	

CITROËN

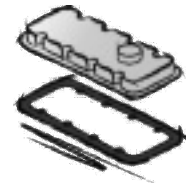
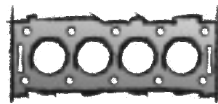
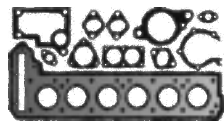

DHV (XUD9BSD)
DHW (XUD9SD)

4 Cyl. 1905 ccm
Cyl. 83,0 Ø

Xantia SD

02/1996 → 04/2003

Xsara D

02/1998 → 05/1999

Xsara SD

01/1998 → 09/2000

S⊕* **581.128**
0197.H5



ES⊕ **116.580**



CS* **984.817**

147.522
0209.Y5



→ 0,670 mm

1,34 mm $\frac{\pm}{\pm}$ 84 Ø
1 ▽

147.532
0209.Y6



→ 0,710 mm

1,39 mm $\frac{\pm}{\pm}$ 84 Ø
2 ▽

147.542
0209.Y7

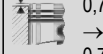

→ 0,750 mm

1,44 mm $\frac{\pm}{\pm}$ 84 Ø
3 ▽

147.552
0209.Y8



→ 0,790 mm

1,49 mm $\frac{\pm}{\pm}$ 84 Ø
4 ▽

147.562
0209.Y9



→ 0,830 mm

1,54 mm $\frac{\pm}{\pm}$ 84 Ø
5 ▽

422.511
0209.T7

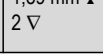

→ 1,59 mm $\frac{\pm}{\pm}$ 84 Ø











2 ▽

ZKS 758.230
0204.66 (10x)
M 12x1,5x123



581.305
0249.91



			<p>a) </p> <p>b) </p>	<p>K: </p> <p>N: </p>	
<p>VAS 294.250 FPM</p> <p>294.110 0956.22 FPM 8x</p>	<p>⇒</p>	<p>919.829 0348.J0</p> 	<p>a) 590.984 0304.34</p>  <p>b) 877.950 incl. 813.036 M 14x1,25x13</p> <p>b) 813.036 0313.27 CU C 14x20x2</p>	<p>K:← 508.233 0326.22 ASW RD FPM/ACM 42x62x7</p> <p>K:→ 508.209 0127.28 ASW LD FPM/ACM 90x110x7</p> <p>N:← 302.589 0236.15 A WD FPM 35x50x8</p>	<p>TLS 453.800</p> 

CITROËN

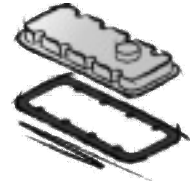
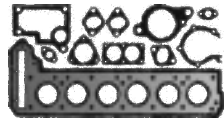

D8B (XUD9TE)/(XUD9TF)
D8C (XUD9UTF)
DHX (XUD9TF/BTF)
DHY (XUD9TE/Y)

4 Cyl. **1905 ccm**
 Cyl. 83,0 Ø

Evasion TD
 11/1994 → 07/2002

Jumper TD
 02/1994 → 04/2002

Jumpy TD
 10/1995 → 10/2006

Xantia TD
 05/1993 → 04/2003

Xsara TD
 04/1997 → 09/2000

ZX TD
 06/1992 → 10/1997

S⊕* **581.128**
 0197.H5



ES⊕ **116.580**



CS* **984.817**

147.522
 0209.Y5



→ 0,670 mm

1,34 mm $\frac{\pm}{\pm}$ 84 Ø
 1 ▽

147.532
 0209.Y6

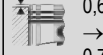

→ 0,670 mm

→ 0,710 mm

1,39 mm $\frac{\pm}{\pm}$ 84 Ø
 2 ▽

147.542
 0209.Y7

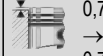

→ 0,710 mm

→ 0,750 mm

1,44 mm $\frac{\pm}{\pm}$ 84 Ø
 3 ▽

147.552
 0209.Y8

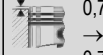

→ 0,750 mm

→ 0,790 mm

1,49 mm $\frac{\pm}{\pm}$ 84 Ø
 4 ▽

147.562
 0209.Y9



→ 0,790 mm

→ 0,830 mm

1,54 mm $\frac{\pm}{\pm}$ 84 Ø
 5 ▽

422.511
 0209.T7

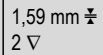

→ 1,59 mm $\frac{\pm}{\pm}$ 84 Ø











2 ▽

ZKS 582.630
 0204.98 (10x)
 M 12x1,5x148



581.305
 0249.91



			<p>a) </p> <p>b) </p>	<p>K: </p> <p>N: </p>	
<p>VAS 294.250 FPM</p> <p>294.110 0956.22 FPM 8x</p>	<p>⇒</p>	<p>919.829 0348.J0</p> 	<p>a) 590.984 0304.34</p>  <p>b) 877.950 incl. 813.036 M 14x1,25x13</p> <p>b) 813.036 0313.27 CU C 14x20x2</p>	<p>K:← 508.233 0326.22 ASW RD FPM/ACM 42x62x7</p> <p>K:→ 508.209 0127.28 ASW LD FPM/ACM 90x110x7</p> <p>N:← 302.589 0236.15 A WD FPM 35x50x8</p>	<p>TLS 453.800</p> 

CITROËN

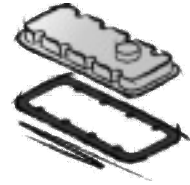
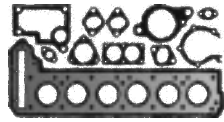

AHM (DW10FUE)
AHN (DW10FUD)
AHP (DW10FUC)

4 Cyl. 1997 ccm
 Cyl. 85,0 Ø

Jumper HDI
 07/2015 → 09/2019

S⊕* **928.970**



ES⊕ **884.220**



OKS **868.220**

228.512

98 070 922 80

 0,450 mm

→

0,500 mm

1,25 mm $\frac{+}{-}$ 86,5 Ø

1 ⊗

228.522

98 418 237 80

 0,500 mm

→

0,550 mm

1,30 mm $\frac{+}{-}$ 86,5 Ø

2 ⊗

228.532

98 418 253 80

 0,550 mm

→

0,600 mm

1,35 mm $\frac{+}{-}$ 86,5 Ø

3 ⊗

228.542

98 418 128 80

 0,600 mm

→

0,650 mm

1,40 mm $\frac{+}{-}$ 86,5 Ø

4 ⊗

964.581

98 418 270 80

 0,650 mm

→

0,700 mm

1,45 mm $\frac{+}{-}$ 86,5 Ø

2 ⊗

ZKS **267.551**

0204.A6 (10x)

M 12x1,5x121











793.570

98 012 929 80

656.350

98 019 077 80



			<p>a) </p> <p>b) </p>	<p>K: </p> <p>N: </p>	
<p>VAS 453.750 FPM</p>	<p>750.931 98 180 699 80</p>		<p>a) 036.164 Dirko HT / EU</p> <p>a) 510.031 Dirko HT / USA/CDN/MEX</p> <p>a) 527.291 Dirko HT / RU</p> <p>a) 648.661 Dirko HT / BR</p> <p>b) 813.052 0164.30 CU C 16x22x2</p>	<p>K:← 393.990 0127.47 ASW RD PTFE/ACM 42x62x7</p> <p>K:→ 394.012 0127.45 ASW LD PTFE/ACM 90x110x8</p> <p>N:← 153.740 0807.28 ASW RD FPM 27x47x7</p>	

CITROËN

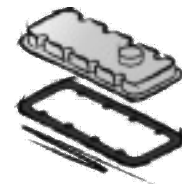
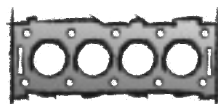
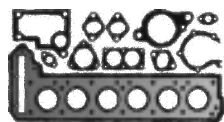

AHE (DW10FD)
 AHF (DW10FD)
 AHG (DW10FD)
 AHH (DW10FC)
 AHJ (DW10FE)
 AHK (DW10FE)
 AHR (DW10FD)
 AHS (DW10FD)
 AHT (DW10FC)
 AHU (DW10FCD)/(DW10FD)
 AHV (DW10FCD)/(DW10FD)
 AHW (DW10FC)
 AHX (DW10FCD)/(DW10FD)
 EHS (DW10FDDU370)
 EHT (DW10FDDU340)
 EHW (DW10FCD)
 EHY (DW10FCC)
 EHZ (DW10FC)/
 (DW10FDCU)

4 Cyl. 1997 ccm
 Cyl. 85,0 Ø

C4 HDI

11/2009 →

C4 Picasso HDI

06/2013 →

C4 Spacetourer HDI

04/2018 →

C5 Aircross HDI

11/2018 →

C5 HDI

04/2009 →

DS 4 HDI

09/2011 → 07/2015

DS 5 HDI

08/2013 → 07/2015

Grand C4 HDI

04/2018 →

Jumpy HDI

04/2016 →

Spacetourer HDI

04/2016 →

S⊕* **928.970**



ES⊕ **884.220**



CS* **868.260**

OKS **868.220**

228.512

98 070 922 80

0,450 mm



→ 0,500 mm

1,25 mm $\frac{\pm}{\pm}$ 86,5 Ø

1 ⊗

228.522

98 418 237 80

0,500 mm



→ 0,550 mm

1,30 mm $\frac{\pm}{\pm}$ 86,5 Ø

2 ⊗

228.532

98 418 253 80

0,550 mm



→ 0,600 mm

1,35 mm $\frac{\pm}{\pm}$ 86,5 Ø

3 ⊗

228.542

98 418 128 80

0,600 mm



→ 0,650 mm

1,40 mm $\frac{\pm}{\pm}$ 86,5 Ø

4 ⊗

964.581

98 418 270 80

0,650 mm



→ 0,700 mm

1,45 mm $\frac{\pm}{\pm}$ 86,5 Ø

2 ⊗

ZKS **267.551**

0204.A6 (10x)

M 12x1,5x121

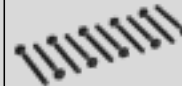

793.570

98 012 929 80

656.350

98 019 077 80



RFH (EW10A)

RFJ (EW10A)

4 Cyl. 1997 ccm
 Cyl. 85,0 Ø

C4

11/2004 →

C4 Picasso

10/2006 → 08/2013

C5

09/2004 →

C8

06/2004 →

Jumpy

01/2007 → 03/2016

ES⊕ **687.820**



CS* **688.000**

165.980

0209.FS

0,70 mm $\frac{\pm}{\pm}$ 86 Ø

2 ∇

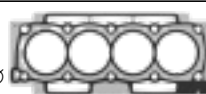























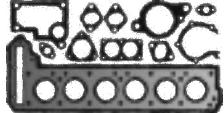
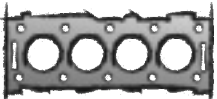

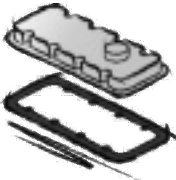





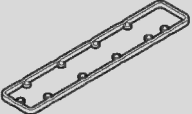
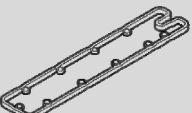

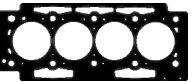
ZKS **453.490**

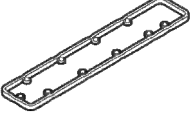
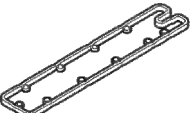













0204.A3 (10x)

M 11x1,5x127



			<p>a) </p> <p>b) </p>	<p>K: </p> <p>N: </p>	
<p>VAS 453.750 FPM</p>	<p>750.931 98 180 699 80</p>		<p>a) 036.164 Dirko HT / EU</p> <p>a) 510.031 Dirko HT / USA/CDN/MEX</p> <p>a) 527.291 Dirko HT / RU</p> <p>a) 648.661 Dirko HT / BR</p> <p>a) 792.230 98 014 448 80</p>  <p>b) 821.290 9801444780</p> <p>b) 163.480 16 168 541 80 ACM RD 30x37</p>	<p>K:← 393.990 0127.47 ASW RD PTFE/ACM 42x62x7</p> <p>K:→ 394.012 0127.45 ASW LD PTFE/ACM 90x110x8</p> <p>N:← 153.740 0807.28 ASW RD FPM 27x47x7</p>	<p>TLS 884.230</p> 
<p>VAS 155.750 FPM</p> <p>149.360 0956.45 FPM 16x</p>	<p>339.490 0349.L0</p> 	<p>365.030 0348.S4 4x</p> 	<p>a) 036.164 Dirko HT / EU</p> <p>a) 510.031 Dirko HT / USA/CDN/MEX</p> <p>a) 527.291 Dirko HT / RU</p> <p>a) 648.661 Dirko HT / BR</p> <p>b) 813.036 0313.27 CU C 14x20x2</p>	<p>K:← 026.750 0127.42 ASW RD PTFE/FPM 40x55x6,4</p> <p>K:→ 508.209 0127.28 ASW LD FPM/ACM 90x110x7</p> <p>N:← 505.366 0236.44 ASW RD FPM/ACM 36x50x7</p> <p>N: 655.190 0236.74 ASW RD PTFE/ACM 39x50x7 E</p>	

CITROËN 				
RFK (EW10J4S) 4 Cyl. 1997 ccm Cyl. 85,0 Ø C4 11/2004 → 12/2010	ES⊕ 878.160  CS* 458.810	125.911 0209.Z3 85,5 Ø  724.500 0209.EP 1,10 mm ± 85,5 Ø  724.510 0209.EQ 1,40 mm ± 85,5 Ø 	ZKS 453.490 0204.A3 (10x) M 11x1,5x127 	331.540 0249.A4 E  331.550 0249.A5 A 
RFN (EW10J4) 4 Cyl. 1997 ccm Cyl. 85,0 Ø C4 11/2004 → 11/2014 C4 Picasso 05/2008 → 05/2013 C5 03/2001 → 08/2004 C8 07/2002 → Evasion 05/2000 → 07/2002 Jumpy 03/2000 → 12/2006 Xsara 09/2000 → 08/2005 Xsara Picasso 12/1999 → 06/2012	ES⊕ 331.600 CS* 458.810	125.911 0209.Z3 85,5 Ø  724.500 0209.EP 1,10 mm ± 85,5 Ø  724.510 0209.EQ 1,40 mm ± 85,5 Ø 	ZKS 262.820 0204.A7 (10x) M 11x1,5x141 	331.540 0249.A4 E  331.550 0249.A5 A 
AHY (DW10CE) AHZ (DW10CD) RHA (DW10CTED4) RHC (DW10CTED4) RHD (DW10CB)/ (DW10CTED4) RHE (DW10CDTR)/ (DW10CTED4) RHH (DW10CTED4) 4 Cyl. 1997 ccm Cyl. 85,0 Ø C4 HDI 11/2009 → C4 Picasso HDI 07/2009 → C5 HDI 02/2008 → C8 HDI 03/2006 → DS 4 HDI 04/2011 → 07/2015 DS 5 HDI 11/2011 → 07/2015 Jumpy HDI 07/2010 →	S⊕* 587.250  ES⊕ 587.150  CS* 572.860	442.802 0209.GL 1,25 mm ± 85,8 Ø  1 ⊗ 442.812 0209.GN 1,30 mm ± 85,8 Ø  2 ⊗ 442.822 0209.GP 1,35 mm ± 85,8 Ø  3 ⊗ 442.832 0209.GQ 1,40 mm ± 85,8 Ø  2 ⊗	ZKS 267.551 0204.A6 (10x) M 12x1,5x121 	453.500 0348.V7 

			<p>a) </p> <p>b) </p>	<p>K: </p> <p>N: </p>	
<p>VAS 155.750 FPM 149.360 0956.45 FPM 16x</p>	<p>136.690 0349.H8 </p>	<p>075.400 0348.R8 </p>	<p>a) 036.164 Dirko HT / EU a) 510.031 Dirko HT / USA/CDN/MEX a) 527.291 Dirko HT / RU a) 648.661 Dirko HT / BR b) 813.036 0313.27 CU C 14x20x2</p>	<p>K:← 076.220 0326.27 AS RD FPM 40x55x6,5 K:→ 508.209 0127.28 ASW LD FPM/ACM 90x110x7 N:← 505.366 0236.44 ASW RD FPM/ACM 36x50x7 2x</p>	
<p>VAS 155.750 FPM 149.360 0956.45 FPM 16x</p>	<p>136.690 0349.H8 </p>	<p>216.500 0348.P1 4x </p>	<p>a) 036.164 Dirko HT / EU a) 510.031 Dirko HT / USA/CDN/MEX a) 527.291 Dirko HT / RU a) 648.661 Dirko HT / BR b) 813.036 0313.27 CU C 14x20x2</p>	<p>K:← 076.220 0326.27 AS RD FPM 40x55x6,5 K:→ 508.209 0127.28 ASW LD FPM/ACM 90x110x7 N:← 505.366 0236.44 ASW RD FPM/ACM 36x50x7 2x</p>	
<p>VAS 453.750 FPM</p>	<p>521.960 0349.N2 </p>		<p>a) 036.164 Dirko HT / EU a) 510.031 Dirko HT / USA/CDN/MEX a) 527.291 Dirko HT / RU a) 648.661 Dirko HT / BR b) 877.930 incl. 108.502 M 10x1,25x13 b) 108.502 0313.40 CU A 10x21x2,1</p>	<p>K:← 393.990 0127.47 ASW RD PTFE/ACM 42x62x7 K:→ 394.012 0127.45 ASW LD PTFE/ACM 90x110x8 N:← 153.740 0807.28 ASW RD FPM 27x47x7</p>	<p>TLS 587.210 </p>

CITROËN

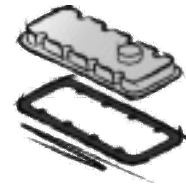
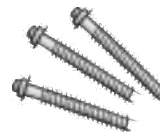
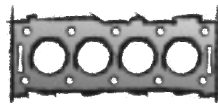
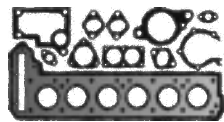

RHF (DW10BTED4)
RHJ (DW10BTED4)
RHK (DW10UTED4)
RHR (DW10BTED4)

4 Cyl. 1997 ccm
Cyl. 85,0 Ø

C4 HDI

11/2004 → 07/2011

C4 Picasso HDI

10/2006 → 12/2013

C5 HDI

09/2004 →

C8 HDI

03/2006 →

Jumpy HDI

01/2007 → 03/2016

S⊕* **527.660**
0197.AE



ES⊕ **527.550**



135.052
0209.AV

0,550 mm
→
0,600 mm
1,25 mm $\frac{\pm}{\pm}$ 86 Ø
1 ⊗



153.002
0209.AW

0,610 mm
→
0,650 mm
1,30 mm $\frac{\pm}{\pm}$ 86 Ø
2 ⊗



153.142
0209.AX

0,660 mm
→
0,710 mm
1,35 mm $\frac{\pm}{\pm}$ 86 Ø
3 ⊗



135.072
0209.AY

0,710 mm
→
0,750 mm
1,40 mm $\frac{\pm}{\pm}$ 86 Ø
4 ⊗













ZKS **267.551**
0204.A6 (10x)
M 12x1,5x121



ZKHS **540.540**
0348.S3



			<p>a) </p> <p>b) </p>	<p>K: </p> <p>N: </p>	
<p>VAS 155.740 FPM 2x</p> <p>136.940 0956.48 FPM 16x</p>	<p>156.770 0349.J2</p> 	<p>AAS 540.540 0348.S3</p> 	<p>a) 036.164 Dirko HT / EU</p> <p>a) 510.031 Dirko HT / USA/CDN/MEX</p> <p>a) 527.291 Dirko HT / RU</p> <p>a) 648.661 Dirko HT / BR</p> <p>b) 877.950 incl. 813.036 M 14x1,25x13</p> <p>b) 813.036 0313.27 CU C 14x20x2</p>	<p>K:← 393.990 0127.47 ASW RD PTFE/ACM 42x62x7</p> <p>K:→ 394.012 0127.45 ASW LD PTFE/ACM 90x110x8</p> <p>N:← 153.740 0807.28 ASW RD FPM 27x47x7</p>	<p>TLS 714.640</p> 

CITROËN

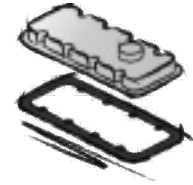
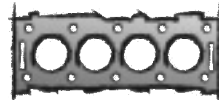
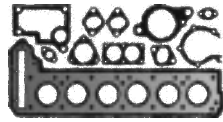

RHV (DW10TD)/(DW10UTD)

4 Cyl. **1997 ccm**
Cyl. 85,0 Ø

Jumper HDI
11/2001 →

S⊕* **449.471**
09/1999→



ES⊕ **262.790**
→08/1999



ES⊕ **851.361**
09/1999→



CS* **851.292**

075.820
0209.X5



0,470 mm
→
0,605 mm
1,30 mm $\frac{\pm}{\pm}$ 86 Ø
1 ▽



075.830
0209.X6



0,605 mm
→
0,655 mm
1,35 mm $\frac{\pm}{\pm}$ 86 Ø
2 ▽



075.840
0209.X7



0,655 mm
→
0,705 mm
1,40 mm $\frac{\pm}{\pm}$ 86 Ø
3 ▽



075.850
0209.X8



0,705 mm
→
0,755 mm
1,45 mm $\frac{\pm}{\pm}$ 86 Ø
4 ▽



075.860
0209.X9



0,755 mm
→
0,830 mm
1,50 mm $\frac{\pm}{\pm}$ 86 Ø
5 ▽



075.870
0209.0J



1,55 mm $\frac{\pm}{\pm}$ 86 Ø
▽▽▽



075.880
0209.0K



1,60 mm $\frac{\pm}{\pm}$ 86 Ø
▽▽▽▽



075.890
0209.0L



1,65 mm $\frac{\pm}{\pm}$ 86 Ø
▽▽▽▽▽





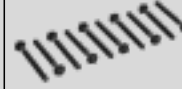







ZKS 267.551
0204.A6 (10x)
M 12x1,5x121



851.560
0249.99

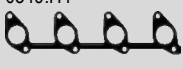
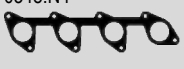

			<p>a) </p> <p>b) </p>	<p>K: </p> <p>N: </p>	
<p>VAS 155.740 FPM 09/1999→</p> <p>403.730 0956.40 0956.38 FPM →08/1999 8x</p> <p>136.940 0956.48 FPM 09/1999→ 8x</p>	<p>044.611 0349.H4</p> 	<p>851.550 0348.N4</p> 	<p>a) 036.164 Dirko HT / EU</p> <p>a) 510.031 Dirko HT / USA/CDN/MEX</p> <p>a) 527.291 Dirko HT / RU</p> <p>a) 648.661 Dirko HT / BR</p> <p>b) 877.950 incl. 813.036 M 14x1,25x13</p> <p>b) 813.036 0313.27 CU C 14x20x2</p>	<p>K:← 508.233 0326.22 ASW RD FPM/ACM 42x62x7</p> <p>K:→ 508.209 0127.28 ASW LD FPM/ACM 90x110x7</p> <p>N:← 153.740 0807.28 ASW RD FPM 27x47x7</p>	<p>TLS 714.620</p> 

CITROËN

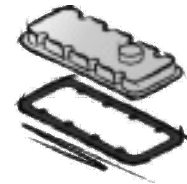
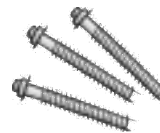
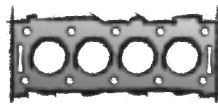
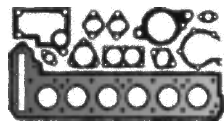

RHM (DW10ATED4)
RHT (DW10ATED4)
RHW (DW10ATED4)

4 Cyl. 1997 ccm
 Cyl. 85,0 Ø

C8 HDI

07/2002 →

Evasion HDI

09/1999 → 10/2002

Jumpy HDI

03/2000 → 10/2006

Xsara Picasso HDI

10/2005 → 12/2011

ES⊕ **216.470**
 0197.Y7
 +0380.20
 +0249.A6



135.052
 0209.AV

 0,550 mm
 →
 0,600 mm
 1,25 mm $\frac{\pm}{\pm}$ 86 Ø
 1 ⊗



153.002
 0209.AW

 0,610 mm
 →
 0,650 mm
 1,30 mm $\frac{\pm}{\pm}$ 86 Ø
 2 ⊗



153.142
 0209.AX

 0,660 mm
 →
 0,710 mm
 1,35 mm $\frac{\pm}{\pm}$ 86 Ø
 3 ⊗



135.072
 0209.AY

 0,710 mm
 →
 0,750 mm
 1,40 mm $\frac{\pm}{\pm}$ 86 Ø
 4 ⊗





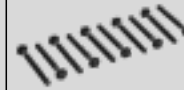



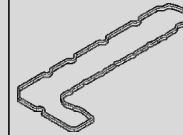



ZKS 267.551
 0204.A6 (10x)
 M 12x1,5x121



154.170
 0249.A6



			<p>a) </p> <p>b) </p>	<p>K: </p> <p>N: </p>	
<p>VAS 155.740 FPM 2x</p> <p>136.940 0956.48 FPM 16x</p>	<p>156.770 0349.J2</p> 		<p>a) 036.164 Dirko HT / EU</p> <p>a) 510.031 Dirko HT / USA/CDN/MEX</p> <p>a) 527.291 Dirko HT / RU</p> <p>a) 648.661 Dirko HT / BR</p> <p>b) 877.950 incl. 813.036 M 14x1,25x13</p> <p>b) 813.036 0313.27 CU C 14x20x2</p>	<p>K:← 508.233 0326.22 ASW RD FPM/ACM 42x62x7</p> <p>K:→ 508.209 0127.28 ASW LD FPM/ACM 90x110x7</p> <p>N:← 153.740 0807.28 ASW RD FPM 27x47x7</p>	<p>TLS 714.610</p> 

CITROËN

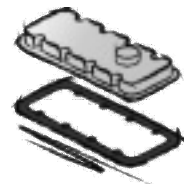
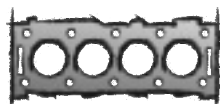
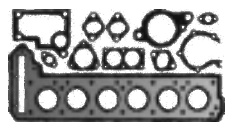

RHX (DW10BTED)

4 Cyl. 1997 ccm
Cyl. 85,0 Ø

Jumpy HDI

10/1999 → 10/2006

S⊕* **449.471**
09/1999 →



ES⊕ **851.361**



CS* **851.292**

075.820
0209.X5



0,470 mm



0,605 mm

1,30 mm $\frac{\pm}{\pm}$ 86 Ø

1 ▽

075.830
0209.X6



0,605 mm



0,655 mm

1,35 mm $\frac{\pm}{\pm}$ 86 Ø

2 ▽

075.840
0209.X7



0,655 mm



0,705 mm

1,40 mm $\frac{\pm}{\pm}$ 86 Ø

3 ▽

075.850
0209.X8



0,705 mm



0,755 mm

1,45 mm $\frac{\pm}{\pm}$ 86 Ø

4 ▽

075.860
0209.X9



0,755 mm



0,830 mm

1,50 mm $\frac{\pm}{\pm}$ 86 Ø

5 ▽

075.870
0209.0J



1,55 mm $\frac{\pm}{\pm}$ 86 Ø

▽▽▽

075.880
0209.0K



1,60 mm $\frac{\pm}{\pm}$ 86 Ø

▽▽▽▽

075.890
0209.0L



1,65 mm $\frac{\pm}{\pm}$ 86 Ø

▽▽▽▽▽

ZKS **267.551**

0204.A6 (10x)



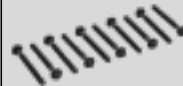







M 12x1,5x121



851.560

0249.99

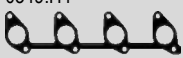
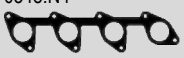

			<p>a) </p> <p>b) </p>	<p>K: </p> <p>N: </p>	
<p>VAS 155.740 FPM 136.940 0956.48 FPM 8x</p>	<p>044.611 0349.H4 </p>	<p>851.550 0348.N4 </p>	<p>a) 036.164 Dirko HT / EU</p> <p>a) 510.031 Dirko HT / USA/CDN/MEX</p> <p>a) 527.291 Dirko HT / RU</p> <p>a) 648.661 Dirko HT / BR</p> <p>b) 877.930 incl. 108.502 M 10x1,25x13</p> <p>b) 877.950 incl. 813.036 M 14x1,25x13</p> <p>b) 108.502 0313.40 CU A 10x21x2,1</p> <p>b) 813.036 0313.27 CU C 14x20x2</p>	<p>K:← 508.233 0326.22 ASW RD FPM/ACM 42x62x7</p> <p>K:→ 508.209 0127.28 ASW LD FPM/ACM 90x110x7</p> <p>N:← 153.740 0807.28 ASW RD FPM 27x47x7</p>	<p>TLS 714.610 </p>

CITROËN

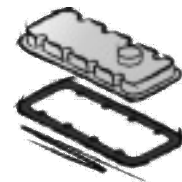
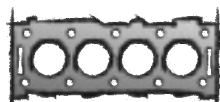
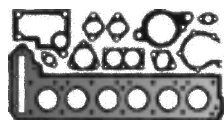

RHS (DW10ATED)
RHY (DW10TD)

4 Cyl. 1997 ccm
Cyl. 85,0 Ø

Berlingo HDI

12/1999 → 12/2011

C5 HDI

03/2001 → 08/2004

Xantia HDI

03/1999 → 04/2003

Xsara HDI

02/1999 → 08/2005

Xsara Picasso HDI

12/1999 → 12/2011

S⊕* **449.471**

09/1999 →



ES⊕ **262.790**

→08/1999



ES⊕ **851.361**

09/1999 →



CS* **851.292**

075.820

0209.X5

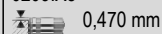

0,470 mm

→

0,605 mm

1,30 mm $\frac{\pm}{\pm}$ 86 Ø

1 ▽

075.830

0209.X6



0,605 mm

→

0,655 mm

1,35 mm $\frac{\pm}{\pm}$ 86 Ø

2 ▽

075.840

0209.X7



0,655 mm

→

0,705 mm

1,40 mm $\frac{\pm}{\pm}$ 86 Ø

3 ▽

075.850

0209.X8

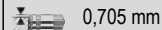

0,705 mm

→

0,755 mm

1,45 mm $\frac{\pm}{\pm}$ 86 Ø

4 ▽

075.860

0209.X9

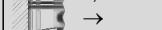

0,755 mm

→

0,830 mm

1,50 mm $\frac{\pm}{\pm}$ 86 Ø

5 ▽

075.870

0209.OJ

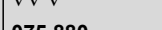

1,55 mm $\frac{\pm}{\pm}$ 86 Ø

▽▽▽

075.880

0209.OK

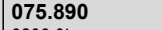

1,60 mm $\frac{\pm}{\pm}$ 86 Ø

▽▽▽▽

075.890

0209.OL



1,65 mm $\frac{\pm}{\pm}$ 86 Ø

▽▽▽▽▽

ZKS 267.551

0204.A6 (10x)







M 12x1,5x121

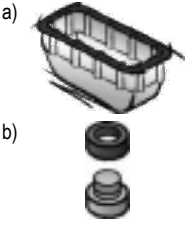
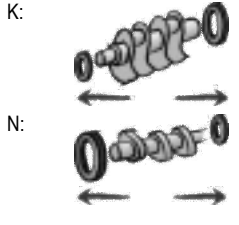

851.560

0249.99

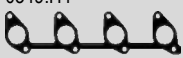
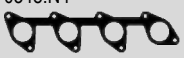

					
<p>VAS 155.740 FPM 09/1999→ 403.730 0956.40 0956.38 FPM →08/1999 8x 136.940 0956.48 FPM 09/1999→ 8x</p>	<p>044.611 0349.H4 </p>	<p>851.550 0348.N4 </p>	<p>a) 036.164 Dirko HT / EU a) 510.031 Dirko HT / USA/CDN/MEX a) 527.291 Dirko HT / RU a) 648.661 Dirko HT / BR b) 877.930 incl. 108.502 M 10x1,25x13 b) 877.950 incl. 813.036 M 14x1,25x13 b) 108.502 0313.40 CU A 10x21x2,1 b) 813.036 0313.27 CU C 14x20x2</p>	<p>K:← 508.233 0326.22 ASW RD FPM/ACM 42x62x7 K:→ 508.209 0127.28 ASW LD FPM/ACM 90x110x7 N:← 153.740 0807.28 ASW RD FPM 27x47x7</p>	<p>TLS 714.630 </p>

CITROËN

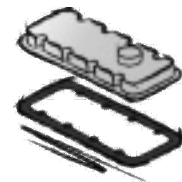
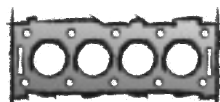
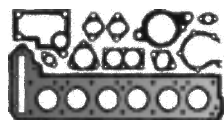

RHZ (DW10ATED)

4 Cyl. 1997 ccm
Cyl. 85,0 Ø

C4 HDI

04/2007 → 12/2011

C5 HDI

03/2001 → 08/2004

Evasion HDI

08/1999 → 10/2002

Jumpy HDI

03/2000 → 10/2006

Xantia HDI

02/1999 → 04/2003

Xsara HDI

05/2001 → 08/2005

S⊕* **449.471**
09/1999→



ES⊕ **262.790**
→08/1999



ES⊕ **851.361**
09/1999→



CS* **851.292**

075.820
0209.X5



0,470 mm



0,605 mm

1,30 mm $\frac{\pm}{\pm}$ 86 Ø

1 ▽

075.830
0209.X6



0,605 mm



0,655 mm

1,35 mm $\frac{\pm}{\pm}$ 86 Ø

2 ▽

075.840
0209.X7



0,655 mm



0,705 mm

1,40 mm $\frac{\pm}{\pm}$ 86 Ø

3 ▽

075.850
0209.X8



0,705 mm



0,755 mm

1,45 mm $\frac{\pm}{\pm}$ 86 Ø

4 ▽

075.860
0209.X9



0,755 mm



0,830 mm

1,50 mm $\frac{\pm}{\pm}$ 86 Ø

5 ▽

075.870
0209.0J



1,55 mm $\frac{\pm}{\pm}$ 86 Ø

▽▽▽

075.880
0209.0K



1,60 mm $\frac{\pm}{\pm}$ 86 Ø

▽▽▽▽

075.890
0209.0L



1,65 mm $\frac{\pm}{\pm}$ 86 Ø

▽▽▽▽▽

ZKS **267.551**

0204.A6 (10x)



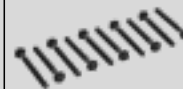









M 12x1,5x121

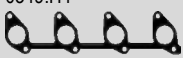
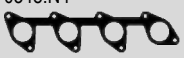

851.560

0249.99



			<p>a) </p> <p>b) </p>	<p>K: </p> <p>N: </p>	
<p>VAS 155.740 FPM 09/1999→ 403.730 0956.40 0956.38 FPM →08/1999 8x 136.940 0956.48 FPM 09/1999→ 8x</p>	<p>044.611 0349.H4 </p>	<p>851.550 0348.N4 </p>	<p>a) 036.164 Dirko HT / EU</p> <p>a) 510.031 Dirko HT / USA/CDN/MEX</p> <p>a) 527.291 Dirko HT / RU</p> <p>a) 648.661 Dirko HT / BR</p> <p>b) 877.930 incl. 108.502 M 10x1,25x13</p> <p>b) 877.950 incl. 813.036 M 14x1,25x13</p> <p>b) 108.502 0313.40 CU A 10x21x2,1</p> <p>b) 813.036 0313.27 CU C 14x20x2</p>	<p>K:← 508.233 0326.22 ASW RD FPM/ACM 42x62x7</p> <p>K:→ 508.209 0127.28 ASW LD FPM/ACM 90x110x7</p> <p>N:← 153.740 0807.28 ASW RD FPM 27x47x7</p>	<p>TLS 714.610 Evasion U6 Jumpy U6 </p> <p>TLS 714.620 Xantia X1/X2 </p> <p>TLS 714.630 C5 C4 Xsara N0/N1/N2 </p>

CITROËN

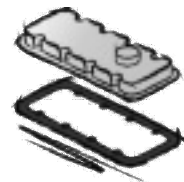
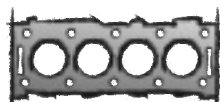
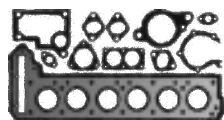

**RHZ (DW10BTED)/
(DW10BTED+)/
(DW10CTED)/(DW10CTED+)**

4 Cyl. 1997 ccm
Cyl. 85,0 Ø

Jumpy HDI
10/2001 → 10/2006

S⊕* **449.471**

09/1999→



ES⊕ **262.790**

→08/1999



ES⊕ **851.361**

09/1999→



CS* **851.292**

075.820

0209.X5

0,470 mm



→

0,605 mm

1,30 mm ± 86 Ø

1 ▽

075.830

0209.X6

0,605 mm



→

0,655 mm

1,35 mm ± 86 Ø

2 ▽

075.840

0209.X7

0,655 mm



→

0,705 mm

1,40 mm ± 86 Ø

3 ▽

075.850

0209.X8

0,705 mm



→

0,755 mm

1,45 mm ± 86 Ø

4 ▽

075.860

0209.X9

0,755 mm



→

0,830 mm

1,50 mm ± 86 Ø

5 ▽

075.870

0209.OJ

1,55 mm ± 86 Ø

▽▽

075.880

0209.OK

1,60 mm ± 86 Ø

▽▽▽

075.890

0209.OL

1,65 mm ± 86 Ø

▽▽▽▽

ZKS 267.551

0204.A6 (10x)

M 12x1,5x121

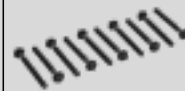

851.560

0249.99



RLZ (EW10D)

4 Cyl. 1997 ccm
Cyl. 85,0 Ø

C5

03/2001 → 08/2004

CS* **458.810**

125.911

0209.Z3

85,5 Ø

724.500

0209.EP

1,10 mm ± 85,5 Ø

724.510

0209.EQ

1,40 mm ± 85,5 Ø

ZKS 262.820

0204.A7 (10x)













M 11x1,5x141





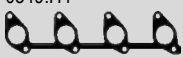
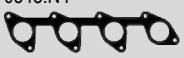





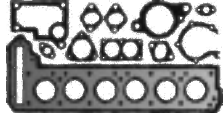
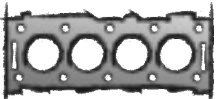

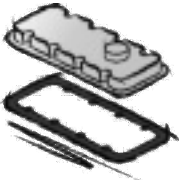





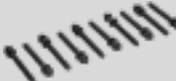

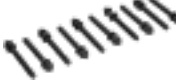
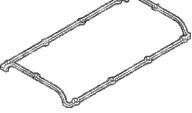







505.180











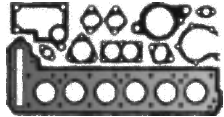
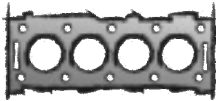

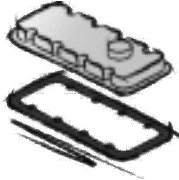







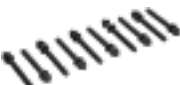

0249.A8



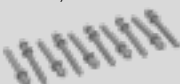

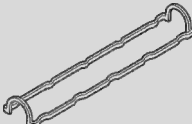













			<p>a) </p> <p>b) </p>	<p>K: </p> <p>N: </p>	
<p>VAS 155.740 FPM 09/1999→ 403.730 0956.40 0956.38 FPM →08/1999 8x 136.940 0956.48 FPM 09/1999→ 8x</p>	<p>044.611 0349.H4 </p>	<p>851.550 0348.N4 </p>	<p>a) 036.164 Dirko HT / EU a) 510.031 Dirko HT / USA/CDN/MEX a) 527.291 Dirko HT / RU a) 648.661 Dirko HT / BR b) 877.930 incl. 108.502 M 10x1,25x13 b) 877.950 incl. 813.036 M 14x1,25x13 b) 108.502 0313.40 CU A 10x21x2,1 b) 813.036 0313.27 CU C 14x20x2</p>	<p>K:← 508.233 0326.22 ASW RD FPM/ACM 42x62x7 K:→ 508.209 0127.28 ASW LD FPM/ACM 90x110x7 N:← 153.740 0807.28 ASW RD FPM 27x47x7</p>	<p>TLS 714.610 </p> <p>TLS 714.620 </p> <p>TLS 714.630 </p>
<p>VAS 155.750 FPM 149.360 0956.45 FPM 16x</p>			<p>a) 036.164 Dirko HT / EU a) 510.031 Dirko HT / USA/CDN/MEX a) 527.291 Dirko HT / RU a) 648.661 Dirko HT / BR b) 813.036 0313.27 CU C 14x20x2</p>	<p>K:← 076.220 0326.27 AS RD FPM 40x55x6,5 K:→ 508.209 0127.28 ASW LD FPM/ACM 90x110x7 N:← 332.670 0236.65 ASW RD FPM 39x50x7 N:← 505.366 0236.44 ASW RD FPM/ACM 36x50x7</p>	

CITROËN 				
4B11 4 Cyl. 1998 ccm Cyl. 86,0 Ø C4 Aircross 04/2012 → C-Crosser 11/2010 →	S⊕* 459.760	415.690 16 062 325 80 0,50 mm $\frac{1}{32}$ 87 Ø 	ZKS 657.030 0204.E3 (8x) 0204.E2 (2x) M 11x1,5x165 	434.840 0249.F9 
R6A RDZ (XU10MZ) RFZ (XU10J2) XU102C 4 Cyl. 1998 ccm Cyl. 86,0 Ø XM 05/1989 → 06/1994	ES⊕ 436.530 0197.C9 CS* 436.540	436.521 0209.N1 1,27 mm $\frac{1}{16}$ 87 Ø 	ZKS 152.550 0204.97 (10x) M 12x1,5x123 	590.932 0249.48 AL 
RFS (XU10J4RS) 4 Cyl. 1998 ccm Cyl. 86,0 Ø Xsara 01/1998 → 03/2005 ZX 05/1996 → 10/1997			ZKS 129.900 0204.A0 (10x) M 12x1,5x110 	
RFT (XU10J4/Z) RFY (XU10J4/Z) 4 Cyl. 1998 ccm Cyl. 86,0 Ø Xantia 03/1993 → 01/1998 ZX 07/1992 → 10/1997		436.521 0209.N1 1,27 mm $\frac{1}{16}$ 87 Ø →06/1993 851.101 0209.N0 1,15 mm $\frac{1}{16}$ 87 Ø 06/1993→  	ZKS 129.900 0204.A0 (10x) M 12x1,5x110 	156.680 0249.74 



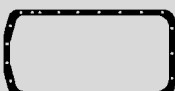





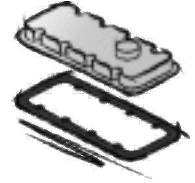
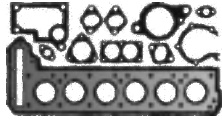



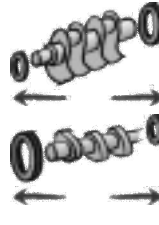

			<p>a) </p> <p>b) </p>	<p>K: </p> <p>N: </p>	
<p>429.320 0956.61 FPM 16x</p>	<p>428.210 0349.N1</p> 	<p>453.060 4x</p> 	<p>a) 036.164 Dirko HT / EU</p> <p>a) 510.031 Dirko HT / USA/CDN/MEX</p> <p>a) 527.291 Dirko HT / RU</p> <p>a) 648.661 Dirko HT / BR</p>	<p>K:← 127.610 0127.57 ASW RD FPM/ACM 42x55x7</p> <p>K:→ 034.560 0127.51 AS LD FPM 85x103x8</p> <p>K:→ 449.290 0127.51 ASW LD FPM 85x103x8</p>	
<p>VAS 294.250 FPM</p> <p>294.110 0956.22 FPM 8x</p>	<p>590.959 0349.70 4x</p> 		<p>a) 590.984 0304.34</p>  <p>b) 877.950 incl. 813.036 M 14x1,25x13</p> <p>b) 813.036 0313.27 CU C 14x20x2</p> <p>b) 813.052 0164.30 CU C 16x22x2</p>	<p>K:← 508.233 0326.22 ASW RD FPM/ACM 42x62x7</p> <p>K:→ 508.209 0127.28 ASW LD FPM/ACM 90x110x7</p> <p>N:← 505.366 0236.44 ASW RD FPM/ACM 36x50x7</p>	
<p>VAS 424.800 FPM</p> <p>403.730 0956.40 0956.38 FPM 16x</p>	<p>076.040 0349.H0</p> 	<p>176.930 0348.C8</p> 	<p>a) 036.164 Dirko HT / EU</p> <p>a) 510.031 Dirko HT / USA/CDN/MEX</p> <p>a) 527.291 Dirko HT / RU</p> <p>a) 648.661 Dirko HT / BR</p> <p>b) 877.950 incl. 813.036 M 14x1,25x13</p> <p>b) 813.036 0313.27 CU C 14x20x2</p>	<p>K:← 508.233 0326.22 ASW RD FPM/ACM 42x62x7</p> <p>K:→ 508.209 0127.28 ASW LD FPM/ACM 90x110x7</p> <p>N:← 505.366 0236.44 ASW RD FPM/ACM 36x50x7 2x</p>	
<p>VAS 825.042 FPM 2x</p> <p>701.289 0956.28 FPM 16x</p>		<p>176.930 0348.C8</p> 	<p>a) 036.164 Dirko HT / EU</p> <p>a) 510.031 Dirko HT / USA/CDN/MEX</p> <p>a) 527.291 Dirko HT / RU</p> <p>a) 648.661 Dirko HT / BR</p> <p>b) 877.950 incl. 813.036 M 14x1,25x13</p> <p>b) 813.036 0313.27 CU C 14x20x2</p>	<p>K:← 508.233 0326.22 ASW RD FPM/ACM 42x62x7</p> <p>K:→ 508.209 0127.28 ASW LD FPM/ACM 90x110x7</p> <p>N:← 505.366 0236.44 ASW RD FPM/ACM 36x50x7 2x</p>	

CITROËN 				
RFU (XU10J2/C) 4 Cyl. 1998 ccm Cyl. 86,0 Ø Evasion 06/1994 → 07/2002	ES⊕ 219.170 0197.T8 CS* 436.540	219.071 0209.J8 1,25 mm $\frac{1}{8}$ 87 Ø 	ZKS 152.550 0204.97 (10x) M 12x1,5x123 	590.932 0249.48 AL  
RFV (XU10J4R) 4 Cyl. 1998 ccm Cyl. 86,0 Ø Evasion 05/1998 → 04/2000 Xantia 06/1995 → 04/2003 XM 05/1989 → 10/2000 Xsara 07/1998 → 09/2000	S⊕* 872.250 09/1998→  ES⊕ 182.010 →12/1996  ES⊕ 182.050 09/1998→  CS* 258.760	851.091 0209.N6 1,15 mm $\frac{1}{8}$ 87 Ø  183.411 0209.T9 1,35 mm $\frac{1}{4}$ 87 Ø 	ZKS 129.900 0204.A0 (10x) M 12x1,5x110 05/2000→ 	152.307 0249.A2 E  152.317 0249.A3 A 
RFX (XU10J2C) RFX XU10J2C/Z L3 4 Cyl. 1998 ccm Cyl. 86,0 Ø Xantia 03/1993 → 04/2003 ZX 07/1992 → 10/1997	ES⊕ 218.970 0197.G6 CS* 436.540	219.071 0209.J8 1,25 mm $\frac{1}{8}$ 87 Ø 	ZKS 152.550 0204.97 (10x) M 12x1,5x123 	023.711 0249.71 PLASTIC  
RGX (XU10J2TE) RGY (XU10J2TE/Z) 4 Cyl. 1998 ccm Cyl. 86,0 Ø Evasion 06/1994 → 07/2002 Xantia 06/1995 → 04/2003 XM 09/1992 → 10/2000	CS* 436.540	331.740 0209.L9 1,20 mm $\frac{1}{4}$ 87 Ø 	ZKS 152.550 0204.97 (10x) M 12x1,5x123 	590.932 0249.48 AL  

			<p>a) </p> <p>b) </p>	<p>K: </p> <p>N: </p>	
<p>VAS 294.250 FPM 294.110 0956.22 FPM 8x</p>	<p>590.959 0349.70 4x</p> 	<p>505.020 0348.N0 2x</p> 	<p>a) 590.984 0304.34</p>  <p>b) 877.950 incl. 813.036 M 14x1,25x13 b) 813.036 0313.27 CU C 14x20x2</p>	<p>K:← 508.233 0326.22 ASW RD FPM/ACM 42x62x7 K:→ 508.209 0127.28 ASW LD FPM/ACM 90x110x7 N:← 505.366 0236.44 ASW RD FPM/ACM 36x50x7</p>	
<p>VAS 155.710 FPM →12/1996 VAS 155.720 FPM 01/1997→ →08/1998 VAS 155.750 FPM 09/1998→ 138.310 0956.34 FPM →12/1996 16x 090.970 0956.42 FPM 01/1997→ →08/1998 16x 149.360 0956.45 FPM 09/1998→ 16x</p>	<p>076.040 0349.H0</p> 	<p>176.930 0348.C8 →11/1996</p>  <p>181.340 0348.L3 12/1996→ 4x</p>	<p>a) 036.164 Dirko HT / EU a) 510.031 Dirko HT / USA/CDN/MEX a) 527.291 Dirko HT / RU a) 648.661 Dirko HT / BR b) 877.950 incl. 813.036 M 14x1,25x13 b) 813.036 0313.27 CU C 14x20x2</p>	<p>K:← 508.233 0326.22 ASW RD FPM/ACM 42x62x7 K:→ 508.209 0127.28 ASW LD FPM/ACM 90x110x7 N:← 505.366 0236.44 ASW RD FPM/ACM 36x50x7 2x</p>	
<p>VAS 294.250 FPM 294.110 0956.22 FPM 8x</p>		<p>505.020 0348.N0 2x</p> 	<p>a) 590.984 0304.34</p>  <p>b) 877.950 incl. 813.036 M 14x1,25x13 b) 813.036 0313.27 CU C 14x20x2</p>	<p>K:← 508.233 0326.22 ASW RD FPM/ACM 42x62x7 K:→ 508.209 0127.28 ASW LD FPM/ACM 90x110x7 N:← 505.366 0236.44 ASW RD FPM/ACM 36x50x7</p>	
<p>VAS 294.250 FPM 294.110 0956.22 FPM 8x</p>		<p>505.020 0348.N0 2x 11/1997→</p> 	<p>a) 590.984 0304.34</p>  <p>b) 877.950 incl. 813.036 M 14x1,25x13 b) 813.036 0313.27 CU C 14x20x2</p>	<p>K:← 508.233 0326.22 ASW RD FPM/ACM 42x62x7 K:→ 508.209 0127.28 ASW LD FPM/ACM 90x110x7 N:← 505.366 0236.44 ASW RD FPM/ACM 36x50x7</p>	

CITROËN



			<p>a) </p> <p>b) </p>	<p>K: </p> <p>N: </p>	
<p>VAS 294.250 FPM 294.110 0956.22 FPM 8x</p>	<p>590.959 0349.70 4x</p> 	<p>023.540 0348.E6 2x</p>  <p>023.680 0348.F6 2x</p> 	<p>a) 590.984 0304.34</p>  <p>b) 877.950 incl. 813.036 M 14x1,25x13</p> <p>b) 813.036 0313.27 CU C 14x20x2</p> <p>b) 813.052 0164.30 CU C 16x22x2</p>	<p>K:← 508.233 0326.22 ASW RD FPM/ACM 42x62x7</p> <p>K:→ 508.209 0127.28 ASW LD FPM/ACM 90x110x7</p> <p>N:← 505.366 0236.44 ASW RD FPM/ACM 36x50x7</p>	
<p>VAS 294.250 FPM 294.110 0956.22 FPM 8x</p>	<p>590.959 0349.70 4x</p> 	<p>023.540 0348.E6 2x</p>  <p>023.680 0348.F6 2x</p> 	<p>a) 590.984 0304.34</p>  <p>b) 877.950 incl. 813.036 M 14x1,25x13</p> <p>b) 813.036 0313.27 CU C 14x20x2</p>	<p>K:← 508.233 0326.22 ASW RD FPM/ACM 42x62x7</p> <p>K:→ 508.209 0127.28 ASW LD FPM/ACM 90x110x7</p> <p>N:← 505.366 0236.44 ASW RD FPM/ACM 36x50x7</p>	

CITROËN

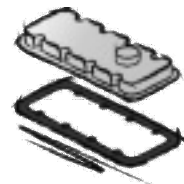
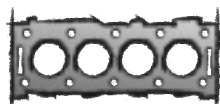
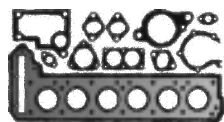

P8A (XUD11ATE)
P8C (XUD11BTE)
PHZ (XUD11ATE)
PJZ (XUD11ATE)

4 Cyl. **2088 ccm**
 Cyl. 85,0 Ø

Evasion TD
 05/1996 → 07/2002

Xantia TD
 06/1995 → 02/1999

XM TD
 05/1989 → 10/2000

ES⊕ **436.581**
 0197.H1



422.531
 0209.T6

0,540 mm
 →
 0,640 mm
 1,35 mm $\frac{+}{-}$ 86 Ø

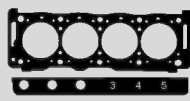

147.001
 0209.R4

0,640 mm
 →
 0,760 mm
 1,52 mm $\frac{+}{-}$ 86 Ø

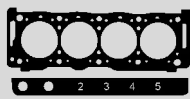

147.011
 0209.R5

0,760 mm
 →
 0,810 mm
 1,57 mm $\frac{+}{-}$ 86 Ø

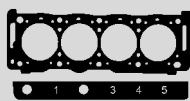

147.021
 0209.R6

0,810 mm
 →
 0,860 mm
 1,62 mm $\frac{+}{-}$ 86 Ø

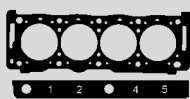

147.031
 0209.R7

0,860 mm
 →
 0,910 mm
 1,67 mm $\frac{+}{-}$ 86 Ø

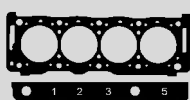

147.041
 0209.R8

0,910 mm
 →
 0,960 mm
 1,72 mm $\frac{+}{-}$ 86 Ø

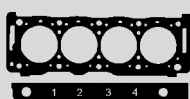

422.551
 0209.T4

1,77 mm $\frac{+}{-}$ 86 Ø



ZKS 758.240
 0204.67 (10x)
 M 12x1,5x148
 →02/1992



ZKS 758.260
 0204.68 (10x)
 M 12x1,5x150
 02/1992→



773.950
 0249.70



P9A (XUD11A)

4 Cyl. **2138 ccm**
 Cyl. 86,0 Ø

XM D
 05/1989 → 08/1996

ES⊕ **436.581**
 0197.H1



436.550 ●
 0209.H1

0,540 mm
 →
 0,640 mm
 1,59 mm $\frac{+}{-}$ 87,5 Ø

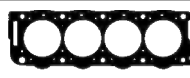

436.570 ●
 0209.99

0,640 mm
 →
 0,760 mm
 1,69 mm $\frac{+}{-}$ 87,5 Ø

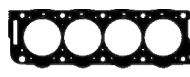















ZKS 758.240
 0204.67 (10x)
 M 12x1,5x148



773.950
 0249.70



			<p>a) </p> <p>b) </p>	<p>K: </p> <p>N: </p>	
<p>VAS 734.240 294.110 0956.22 FPM 12x</p>	<p>439.760 0349.76</p> 	<p>439.770 0348.96</p> 	<p>a) 590.984 0304.34</p>  <p>b) 877.950 incl. 813.036 M 14x1,25x13</p> <p>b) 813.036 0313.27 CU C 14x20x2</p>	<p>K:← 508.233 0326.22 ASW RD FPM/ACM 42x62x7</p> <p>K:→ 508.209 0127.28 ASW LD FPM/ACM 90x110x7</p> <p>N:← 302.589 0236.15 A WD FPM 35x50x8</p>	
<p>VAS 734.240 294.110 0956.22 FPM 12x</p>	<p>439.760 0349.76</p> 	<p>439.770 0348.96</p> 	<p>a) 590.984 0304.34</p>  <p>b) 877.950 incl. 813.036 M 14x1,25x13</p> <p>b) 813.036 0313.27 CU C 14x20x2</p>	<p>K:← 508.233 0326.22 ASW RD FPM/ACM 42x62x7</p> <p>K:→ 508.209 0127.28 ASW LD FPM/ACM 90x110x7</p> <p>N:← 302.589 0236.15 A WD FPM 35x50x8</p>	

CITROËN

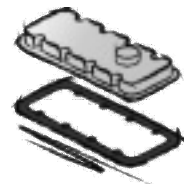
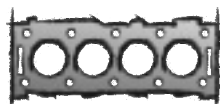
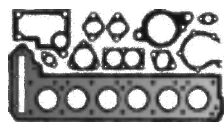

4HB (DW12RUD)
4HH (DW12RUC)
4HK (DW12RUE)

4 Cyl. **2179 ccm**
 Cyl. 85,0 Ø

Jumper HDI
 08/2019 →

S⊕* **928.970**



ES⊕ **884.220**



CS* **868.260**

OKS **868.220**

228.512

98 070 922 80

0,450 mm



→ 0,500 mm

1,25 mm $\frac{+}{-}$ 86,5 Ø

1 ⊗

228.522

98 418 237 80

0,500 mm



→ 0,550 mm

1,30 mm $\frac{+}{-}$ 86,5 Ø

2 ⊗

228.532

98 418 253 80

0,550 mm



→ 0,600 mm

1,35 mm $\frac{+}{-}$ 86,5 Ø

3 ⊗

228.542

98 418 128 80

0,600 mm



→ 0,650 mm

1,40 mm $\frac{+}{-}$ 86,5 Ø

4 ⊗

964.581

98 418 270 80

0,650 mm



→ 0,700 mm

1,45 mm $\frac{+}{-}$ 86,5 Ø

2 ⊗

ZKS 267.551

0204.A6 (10x)

M 12x1,5x121



793.570

98 012 929 80

656.350

98 019 077 80



4HL (DW12C)

4 Cyl. **2179 ccm**
 Cyl. 85,0 Ø

C5 HDI
 07/2010 →

ES⊕ **472.060**



CS* **729.880**

732.160

0209.FT

0,550 mm



→ 0,600 mm

1,25 mm $\frac{+}{-}$ 86 Ø

1 ⊗

732.170

0209.FV

0,610 mm



→ 0,650 mm

1,30 mm $\frac{+}{-}$ 86 Ø

2 ⊗

732.180

0209.FW

0,660 mm



→ 0,700 mm

1,35 mm $\frac{+}{-}$ 86 Ø

3 ⊗

732.190

0209.FX

0,710 mm



→ 0,750 mm

1,40 mm $\frac{+}{-}$ 86 Ø

4 ⊗

ZKS 267.551

0204.A6 (10x)

M 12x1,5x121

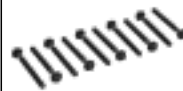













ZKHS 469.070



790.690

0249.E3



			<p>a) </p> <p>b) </p>	<p>K: </p> <p>N: </p>	
<p>VAS 453.750 FPM</p>	<p>750.931 98 180 699 80</p>		<p>a) 036.164 Dirko HT / EU</p> <p>a) 510.031 Dirko HT / USA/CDN/MEX</p> <p>a) 527.291 Dirko HT / RU</p> <p>a) 648.661 Dirko HT / BR</p> <p>a) 792.230 98 014 448 80</p>  <p>b) 523.470 incl. 813.052 0311.39 M 16x1,5x16</p> <p>b) 163.480 16 168 541 80 ACM RD 30x37</p> <p>b) 813.052 0164.30 CU C 16x22x2</p>	<p>K:← 393.990 0127.47 ASW RD PTFE/ACM 42x62x7</p> <p>K:→ 394.012 0127.45 ASW LD PTFE/ACM 90x110x8</p> <p>N:← 153.740 0807.28 ASW RD FPM 27x47x7</p>	<p>TLS 884.230</p> 
<p>VAS 453.750 FPM</p>	<p>456.840 0349.N8</p>	<p>AAS 469.080 0348.T2</p> 	<p>a) 036.164 Dirko HT / EU</p> <p>a) 510.031 Dirko HT / USA/CDN/MEX</p> <p>a) 527.291 Dirko HT / RU</p> <p>a) 648.661 Dirko HT / BR</p> <p>b) 877.930 incl. 108.502 M 10x1,25x13</p> <p>b) 108.502 0313.40 CU A 10x21x2,1</p>	<p>K:← 393.990 0127.47 ASW RD PTFE/ACM 42x62x7</p> <p>K:→ 394.012 0127.45 ASW LD PTFE/ACM 90x110x8</p> <p>N:← 153.740 0807.28 ASW RD FPM 27x47x7</p>	<p>TLS 426.850</p> 

CITROËN

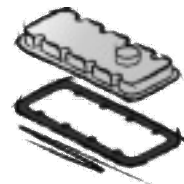
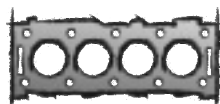
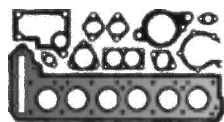

4HK (DW12ME5)
4HN (DW12MTED4)
4HP (DW12BTED4)
4HR (DW12BTED4)
4HS (DW12BTED4)
4HT (DW12BTED4)

4 Cyl. **2179 ccm**
 Cyl. 85,0 Ø

C5 HDI
 04/2006 →
C6 HDI
 06/2006 → 12/2012
C8 HDI
 06/2006 →
C-Crosser HDI
 02/2007 →

ES⊕ **449.600**

 CS* **729.880**

732.160
 0209.FT
 0,550 mm
 →
 0,600 mm
 1,25 mm $\frac{\pm}{\pm}$ 86 Ø
 1 ⊗

732.170
 0209.FV
 0,610 mm
 →
 0,650 mm
 1,30 mm $\frac{\pm}{\pm}$ 86 Ø
 2 ⊗

732.180
 0209.FW
 0,660 mm
 →
 0,700 mm
 1,35 mm $\frac{\pm}{\pm}$ 86 Ø
 3 ⊗

732.190
 0209.FX
 0,710 mm
 →
 0,750 mm
 1,40 mm $\frac{\pm}{\pm}$ 86 Ø
 4 ⊗

ZKS 267.551
 0204.A6 (10x)
 M 12x1,5x121

ZKHS 469.070

790.690
 0249.E3

4HW (DW12TED4)
 4 Cyl. **2179 ccm**
 Cyl. 85,0 Ø

C8 HDI
 07/2002 →

ES⊕ **216.470**
 0197.Y7
 +0380.20
 +0249.A6

 CS* **449.680**

135.052
 0209.AV
 0,550 mm
 →
 0,600 mm
 1,25 mm $\frac{\pm}{\pm}$ 86 Ø
 1 ⊗













153.002
 0209.AW
 0,610 mm
 →
 0,650 mm
 1,30 mm $\frac{\pm}{\pm}$ 86 Ø
 2 ⊗

153.142
 0209.AX
 0,660 mm
 →
 0,710 mm
 1,35 mm $\frac{\pm}{\pm}$ 86 Ø
 3 ⊗

135.072
 0209.AY
 0,710 mm
 →
 0,750 mm
 1,40 mm $\frac{\pm}{\pm}$ 86 Ø
 4 ⊗

ZKS 267.551
 0204.A6 (10x)
 M 12x1,5x121

154.170
 0249.A6

			<p>a) </p> <p>b) </p>	<p>K: </p> <p>N: </p>	
<p>VAS 453.750 FPM</p>	<p>901.840 0349.P1</p> 	<p>AAS 469.080 0348.T2</p> 	<p>a) 036.164 Dirko HT / EU</p> <p>a) 510.031 Dirko HT / USA/CDN/MEX</p> <p>a) 527.291 Dirko HT / RU</p> <p>a) 648.661 Dirko HT / BR</p> <p>b) 877.930 incl. 108.502 M 10x1,25x13</p> <p>b) 108.502 0313.40 CU A 10x21x2,1</p>	<p>K:← 393.990 0127.47 ASW RD PTFE/ACM 42x62x7</p> <p>K:→ 394.012 0127.45 ASW LD PTFE/ACM 90x110x8</p> <p>N:← 153.740 0807.28 ASW RD FPM 27x47x7</p>	
<p>VAS 155.740 FPM 2x</p> <p>136.940 0956.48 FPM 16x</p>	<p>156.770 0349.J2</p> 		<p>a) 036.164 Dirko HT / EU</p> <p>a) 510.031 Dirko HT / USA/CDN/MEX</p> <p>a) 527.291 Dirko HT / RU</p> <p>a) 648.661 Dirko HT / BR</p> <p>b) 877.950 incl. 813.036 M 14x1,25x13</p> <p>b) 813.036 0313.27 CU C 14x20x2</p>	<p>K:← 508.233 0326.22 ASW RD FPM/ACM 42x62x7</p> <p>K:→ 508.209 0127.28 ASW LD FPM/ACM 90x110x7</p> <p>N:← 153.740 0807.28 ASW RD FPM 27x47x7</p>	<p>TLS 745.120</p> 

CITROËN

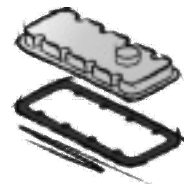
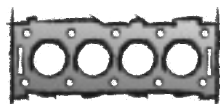
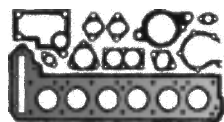

4HX (DW12TED4)
4 Cyl. **2179 ccm**
Cyl. 85,0 Ø

C5 HDI
03/2001 →

ES⊕ **216.470**
0197.Y7
+0380.20
+0249.A6



CS* **449.680**

135.052
0209.AV
 0,550 mm
→
0,600 mm
1,25 mm $\frac{\pm}{\pm}$ 86 Ø
1 ⊗

153.002
0209.AW
 0,610 mm
→
0,650 mm
1,30 mm $\frac{\pm}{\pm}$ 86 Ø
2 ⊗

153.142
0209.AX
 0,660 mm
→
0,710 mm
1,35 mm $\frac{\pm}{\pm}$ 86 Ø
3 ⊗

135.072
0209.AY
 0,710 mm
→
0,750 mm
1,40 mm $\frac{\pm}{\pm}$ 86 Ø
4 ⊗

ZKS **267.551**
0204.A6 (10x)
M 12x1,5x121



154.170
0249.A6

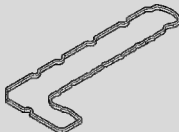

4HY (DW12UTED)
4 Cyl. **2179 ccm**
Cyl. 85,0 Ø

Jumper HDI
02/2002 →

S⊕* **449.471**





ES⊕ **851.361**



CS* **851.292**

431.321
0209.AQ
 0,550 mm
→
0,600 mm
1,25 mm $\frac{\pm}{\pm}$ 86 Ø
1 ⊗

431.331
0209.AR
 0,610 mm
→
0,650 mm
1,30 mm $\frac{\pm}{\pm}$ 86 Ø
2 ⊗

431.341
0209.AS
 0,660 mm
→
0,700 mm
1,35 mm $\frac{\pm}{\pm}$ 86 Ø
3 ⊗













431.351
0209.AT
 0,700 mm
→
0,750 mm
1,40 mm $\frac{\pm}{\pm}$ 86 Ø
4 ⊗

ZKS **267.551**
0204.A6 (10x)
M 12x1,5x121











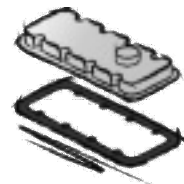
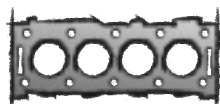
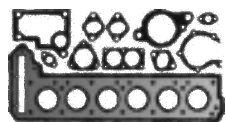











851.560
0249.99

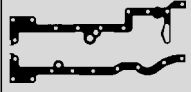









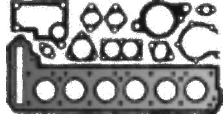
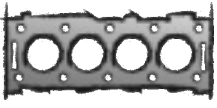

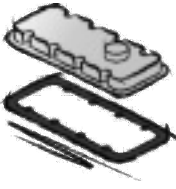

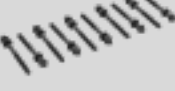
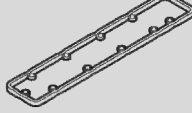
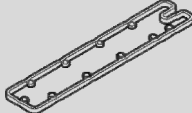

























			<p>a) </p> <p>b) </p>	<p>K: </p> <p>N: </p>	
<p>VAS 155.740 FPM 2x</p> <p>136.940 0956.48 FPM 16x</p>	<p>156.770 0349.J2</p> 		<p>a) 036.164 Dirko HT / EU</p> <p>a) 510.031 Dirko HT / USA/CDN/MEX</p> <p>a) 527.291 Dirko HT / RU</p> <p>a) 648.661 Dirko HT / BR</p> <p>b) 877.950 incl. 813.036 M 14x1,25x13</p> <p>b) 813.036 0313.27 CU C 14x20x2</p>	<p>K:← 508.233 0326.22 ASW RD FPM/ACM 42x62x7</p> <p>K:→ 508.209 0127.28 ASW LD FPM/ACM 90x110x7</p> <p>N:← 153.740 0807.28 ASW RD FPM 27x47x7</p>	<p>TLS 745.110</p> 
<p>VAS 155.740 FPM</p> <p>136.940 0956.48 FPM 8x</p>	<p>044.611 0349.H4</p> 	<p>851.550 0348.N4</p> 	<p>a) 036.164 Dirko HT / EU</p> <p>a) 510.031 Dirko HT / USA/CDN/MEX</p> <p>a) 527.291 Dirko HT / RU</p> <p>a) 648.661 Dirko HT / BR</p> <p>b) 877.950 incl. 813.036 M 14x1,25x13</p> <p>b) 813.036 0313.27 CU C 14x20x2</p>	<p>K:← 508.233 0326.22 ASW RD FPM/ACM 42x62x7</p> <p>K:→ 508.209 0127.28 ASW LD FPM/ACM 90x110x7</p> <p>N:← 153.740 0807.28 ASW RD FPM 27x47x7</p>	<p>TLS 714.620</p> 

CITROËN



			<p>a) </p> <p>b) </p>	<p>K: </p> <p>N: </p>	
<p>027.740 0956.59 FPM 16x</p> 	<p>392.440 0349.L5</p> 	<p>027.150 0348.T1 8x</p> 	<p>a) OWS 027.371 0304.58</p>  <p>a) 036.164 Dirko HT / EU ↓ a) 510.031 Dirko HT / USA/CDN/MEX ↓ a) 527.291 Dirko HT / RU ↓ a) 648.661 Dirko HT / BR ↓ b) 012.001 0311.32 M 14x1,5x20 b) 176.090 13x22,4x3</p>	<p>K:← 026.782 0514.C6 ASW RD PTFE 50x90x14 K:→ 026.812 0514.C4 IWD LD PTFE/ACM 106x215</p>	<p>TLS 577.730</p> 
<p>027.740 0956.59 FPM 16x</p> 	<p>392.440 0349.L5</p> 	<p>AAS 280.350</p>  <p>027.150 0348.T1 8x</p> 	<p>a) OWS 027.371 0304.58</p>  <p>a) 036.164 Dirko HT / EU ↓ a) 510.031 Dirko HT / USA/CDN/MEX ↓ a) 527.291 Dirko HT / RU ↓ a) 648.661 Dirko HT / BR ↓ b) 012.001 0311.32 M 14x1,5x20 b) 176.090 13x22,4x3</p>	<p>K:← 026.782 0514.C6 ASW RD PTFE 50x90x14 K:→ 026.812 0514.C4 IWD LD PTFE/ACM 106x215</p>	<p>TLS 430.140</p> 

CITROËN 				
3FY (EW12J4) 3FZ (EW12J4) 4 Cyl. 2230 ccm Cyl. 86,0 Ø C8 07/2002 →	ES⊕ 375.000 CS* 458.810	170.051 0209.0H 	ZKS 330.060 0204.95 (10x) M 11x1,5x128 	331.540 0249.A4 E  331.550 0249.A5 A 
F1AE0481T 4 Cyl. 2287 ccm Cyl. 88,0 Ø Jumper HDI 08/2008 →	ES⊕ 452.700 ES⊕ 651.930  ES⊕ 733.530 ● 	389.430 0209.HQ  0,300 mm → 0,400 mm 1,10 mm ± 88,5 Ø 389.440 0209.HR  0,400 mm → 0,500 mm 1,20 mm ± 88,5 Ø 389.450 0209.HS  0,500 mm → 0,600 mm 1,30 mm ± 88,5 Ø   	ZKS 464.390 0204.E6 (4x) 0204.E5 (6x)	718.220 0249.G6  452.640 1982.G0 4x
4B12 SFZ (4B12 MMC) 4 Cyl. 2360 ccm Cyl. 88,0 Ø C-Crosser 08/2008 →	S⊕* 440.290	780.910 0209.FN 0,60 mm ± 89 Ø 	ZKS 657.030 0204.E3 (8x) 0204.E2 (2x) M 11x1,5x165 	434.840 0249.F9 
T8A (DJ5T) T9A (DJ5) THY (DK5ATE) THZ (DJ5T) 4 Cyl. 2446 ccm Cyl. 92,0 Ø Jumper D 03/1994 → 04/2002 Jumper TD 03/1994 → 04/2002 XM TD 05/1994 → 10/2000	ES⊕ 711.930 0197.T6 CS* 711.840	711.671 0209.R3 1,50 mm ± 93 Ø 	ZKS 152.480 0204.74 (14x) +0204.75 (8x) M 12x1,5x139 	773.470 0249.79 

			<p>a) </p> <p>b) </p>	<p>K: </p> <p>N: </p>	
<p>VAS 155.750 FPM 149.360 0956.45 FPM 16x</p>	<p>136.690 0349.H8 </p>	<p>331.970 0348.R7 </p>	<p>a) 036.164 Dirko HT / EU a) 510.031 Dirko HT / USA/CDN/MEX a) 527.291 Dirko HT / RU a) 648.661 Dirko HT / BR b) 813.036 0313.27 CU C 14x20x2</p>	<p>K:← 076.220 0326.27 AS RD FPM 40x55x6,5 K:→ 508.209 0127.28 ASW LD FPM/ACM 90x110x7 N:← 332.670 0236.65 ASW RD FPM 39x50x7 N:← 505.366 0236.44 ASW RD FPM/ACM 36x50x7</p>	
<p>718.210 0951.61 FPM 16x </p>	<p>722.140 0349.N7 </p>	<p>718.680 </p>	<p>a) 505.450 0304.62 </p> <p>b) 877.910 incl. 128.503 M 22x1,5x10 b) 128.503 0164.84 CU A 22x27x1,5</p>	<p>K:← 431.110 SP RD FVMQ 50x80x14 K:← 749.250 SP RD PTFE 50x80x11 K:→ 431.120 SP LD FPM 83x113x14 N:← 375.470 A/BS RD FPM 34x60x10</p>	
<p>429.320 0956.61 FPM 16x</p>	<p>428.210 0349.N1 </p>	<p>453.060 4x </p>	<p>a) 036.164 Dirko HT / EU a) 510.031 Dirko HT / USA/CDN/MEX a) 527.291 Dirko HT / RU a) 648.661 Dirko HT / BR</p>	<p>K:← 127.610 0127.57 ASW RD FPM/ACM 42x55x7 K:→ 034.560 0127.51 AS LD FPM 85x103x8 K:→ 449.290 0127.51 ASW LD FPM 85x103x8</p>	
<p>VAS 825.050 FPM 701.289 0956.28 FPM 12x</p>	<p>711.910 0349.E7 </p>	<p>711.880 0348.K1 </p>	<p>a) 036.164 Dirko HT / EU a) 510.031 Dirko HT / USA/CDN/MEX a) 527.291 Dirko HT / RU a) 648.661 Dirko HT / BR b) 813.052 0164.30 CU C 16x22x2</p>	<p>K:← 509.949 0326.25 ASW RD FPM/ACM 64x88x6 K:→ 509.930 0119.14 ASW LD FPM/ACM 98x120x7 N:← 503.754 0807.21 ASW LD FPM/ACM 47,5x62x7 N:← 757.292 0807.14 ASW RD FPM 35x50x7 N:→ 509.957 0807.15 ASW LD FPM/ACM 40x62x7 →10/1995</p>	

CITROËN

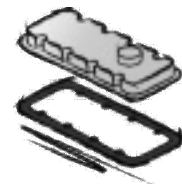
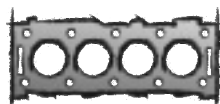
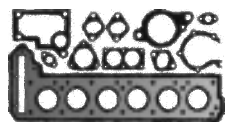

THX (DJ5TED)

4 Cyl. **2446 ccm**
Cyl. 92,0 Ø

Jumper TD

12/1996 → 04/2002

ES⊕ **141.921**
0197.W3
+0249.79



ES⊕ **850.641**
0197.W3
+0249.79
+0209.T5
CS* **711.840**

162.141
0209.T5
1,40 mm $\frac{2}{3}$ 93 Ø



ZKS **152.510**
0204.87 (14x)
+0204.88 (8x)
M 12x1,5x163



773.470
0249.79



DT17ED4 UHZ (DT17BTED4)/ (DT17TED4)

6 Cyl. **2720 ccm**
Cyl. 81,0 Ø

C5 HDI

02/2008 →

C6 HDI

09/2005 → 12/2011

ES⊕ **712.821**

CS* **712.830**

505.640
0209.CW
 0,552 mm
→
0,603 mm
1,17 mm $\frac{2}{3}$ 82,5 Ø
2x
2 ▽



505.650
0209.CX
 0,604 mm
→
0,655 mm
1,22 mm $\frac{2}{3}$ 82,5 Ø
2x
3 ▽



505.660
0209.CY
 0,656 mm
→
0,707 mm
1,27 mm $\frac{2}{3}$ 82,5 Ø
2x
4 ⊗













505.670
0209.CZ
 0,708 mm
→
0,760 mm
1,32 mm $\frac{2}{3}$ 82,5 Ø
2x
5 ▽



584.890
0249.E1
2x

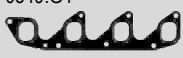

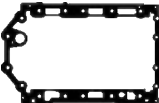
			<p>a) </p> <p>b) </p>	<p>K: </p> <p>N: </p>	
<p>VAS 825.042 FPM 701.289 0956.28 FPM 8x</p>	<p>849.870 0349.G4 </p>	<p>850.650 0348.K4 2x </p>	<p>a) 036.164 Dirko HT / EU a) 510.031 Dirko HT / USA/CDN/MEX a) 527.291 Dirko HT / RU a) 648.661 Dirko HT / BR b) 813.052 0164.30 CU C 16x22x2</p>	<p>K:← 509.949 0326.25 ASW RD FPM/ACM 64x88x6 K:→ 509.930 0119.14 ASW LD FPM/ACM 98x120x7 N:← 757.292 0807.14 ASW RD FPM 35x50x7</p>	
<p>VAS 505.690 505.680 0956.53 FPM 24x</p>	<p>584.910 0349.L0 2x </p>		<p>a) 655.400 0164.75 ↑ </p> <p>a) 655.420 0304.57 b) 813.052 0164.30 CU C 16x22x2</p>	<p>K:← 374.680 0326.28 ASW RD PTFE/ACM 35x50x7 K:→ 655.650 0119.20 SP LD PTFE 92 N:← 339.280 0807.36 ASW WD FPM 26x45x8 2x</p>	

CITROËN

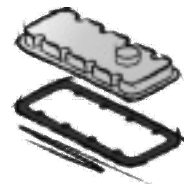
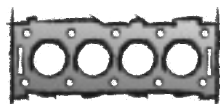
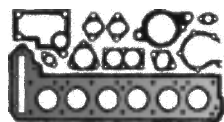

8140.43C

4 Cyl. **2798 ccm**
Cyl. 94,4 Ø

Jumper HDI
06/2003 → 06/2006

S⊕* **198.860**



ES⊕ **198.930**



863.080

0209.OA

→ 0,400 mm
→ 0,500 mm

1,20 mm ±

863.110

0209.OC

→ 0,510 mm
→ 0,600 mm

1,30 mm ±

863.120

0209.OE

→ 0,610 mm
→ 0,700 mm

1,40 mm ±

863.130

0209.OF

→ 0,710 mm
→ 0,800 mm

1,50 mm ±

ZKS 760.300

M 12x1,25x119/163



081.540

0249.A0



8140.43N

4 Cyl. **2798 ccm**
Cyl. 94,4 Ø

Jumper HDI
05/2004 →

S⊕* **181.270**

0197.Z4



ES⊕ **181.320**

0197.Z0



863.080

0209.OA

→ 0,400 mm
→ 0,500 mm

1,20 mm ±

863.110

0209.OC

→ 0,510 mm
→ 0,600 mm

1,30 mm ±

863.120

0209.OE

→ 0,610 mm
→ 0,700 mm

1,40 mm ±

863.130

0209.OF

→ 0,710 mm
→ 0,800 mm

1,50 mm ±

ZKS 374.180



















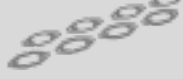

0204.94 (8x)
+0204.92 (14x)
M 12x1,25x90/163



199.060

0249.C3

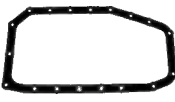

			<p>a) </p> <p>b) </p>	<p>K: </p> <p>N: </p>	
<p>VAS 790.860 FPM 143.930 0956.44 FPM 8x</p>	<p>AAS 898.310 481.300 (4x) +481.320 (4x)</p>  <p>481.320 0349.H5 4x</p> 	<p>481.300 0348.N5 4x</p> 	<p>a) OWS 290.910 0164.68 +0164.69</p>  <p>a) 569.670</p>  <p>b) 877.910 incl. 128.503 M 22x1,5x10</p> <p>b) 878.040 incl. 128.503 M 22x1,5x10</p> <p>b) 128.503 0164.84 CU A 22x27x1,5</p>	<p>K:← 199.220 0514.C1 IWD RD FPM 70x14</p> <p>K:→ 199.230 0514.C2 IWD LD FPM 114x13</p> <p>N:← 419.730 0807.29 AW/BS RD FPM 55x70x8</p>	<p>TLS 715.620</p> 
<p>VAS 790.860 FPM 143.930 0956.44 FPM 8x</p>	<p>AAS 898.310 481.300 (4x) +481.320 (4x)</p>  <p>481.320 0349.H5 4x</p> 	<p>481.300 0348.N5 4x</p> 	<p>a) OWS 290.910 0164.68 +0164.69</p>  <p>a) 429.000 0304.54</p>  <p>b) 877.910 incl. 128.503 M 22x1,5x10</p> <p>b) 878.040 incl. 128.503 M 22x1,5x10</p> <p>b) 128.503 0164.84 CU A 22x27x1,5</p>	<p>K:← 199.220 0514.C1 IWD RD FPM 70x14</p> <p>K:→ 199.230 0514.C2 IWD LD FPM 114x13</p> <p>N:← 419.730 0807.29 AW/BS RD FPM 55x70x8</p>	<p>TLS 286.600</p> 

CITROËN

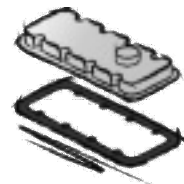
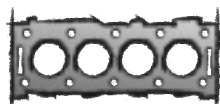
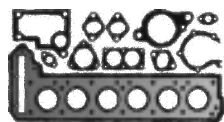

8140.43S
F28TDCR

4 Cyl. **2798 ccm**
Cyl. 94,4 Ø

Jumper HDI
09/2000 →

S⊕* **181.270**
0197.Z4



ES⊕ **181.320**
0197.Z0



863.080
0209.OA



0,400 mm
→
0,500 mm

1,20 mm ±

863.110
0209.OC



0,510 mm
→
0,600 mm

1,30 mm ±

863.120
0209.OE



0,610 mm
→
0,700 mm

1,40 mm ±

863.130
0209.OF



0,710 mm
→
0,800 mm

1,50 mm ±

ZKS 374.180
0204.94 (8x)
+0204.92 (14x)
M 12x1,25x90/163



199.060
0249.C3



8140.63 (F28D)

4 Cyl. **2798 ccm**
Cyl. 94,4 Ø

Jumper D
01/1999 → 02/2002

S⊕* **181.110**



ES⊕ **181.150**



181.010
0209.Z4



0,750 mm
→
0,850 mm

1,60 mm ± 96 Ø

181.060
0209.Z5



0,850 mm
→
0,950 mm

1,70 mm ± 96 Ø
1 ⊗

181.070
0209.Z9



0,950 mm
→
1,050 mm

1,80 mm ± 96 Ø
2 ⊗

ZKS 374.180
0204.94 (8x)
+0204.92 (14x)
M 12x1,25x90/163



199.060
0249.C3



ES9J4SHP
XFX (ES9J4S)

6 Cyl. **2946 ccm**
Cyl. 87,0 Ø

C5
03/2001 →

C6
09/2005 → 12/2012

C8
07/2002 →

123.022
0209.OX



0,74 mm ±
L

123.601
0209.OZ



0,95 mm ±
L

123.032
0209.OY



0,74 mm ±
R

















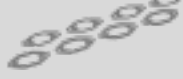

123.611
0209.1A











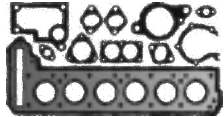
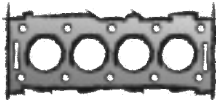

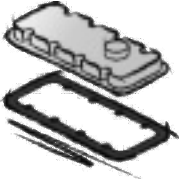

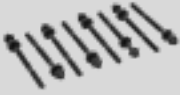



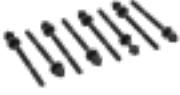













0,95 mm ±
R

ZKS 152.570 ●
0204.86 (8x)
M 10x1,5x148
2x





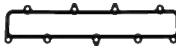





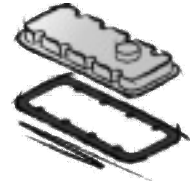
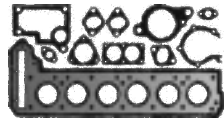





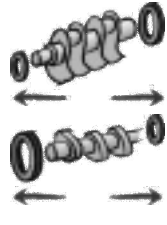

			<p>a) </p> <p>b) </p>	<p>K: </p> <p>N: </p>	
<p>VAS 790.860 FPM 143.930 0956.44 FPM 8x</p>	<p>AAS 898.310 481.300 (4x) +481.320 (4x)</p>  <p>481.320 0349.H5 4x</p> 	<p>481.300 0348.N5 4x</p> 	<p>a) OWS 290.910 0164.68 +0164.69</p>  <p>a) 429.000 0304.54</p>  <p>b) 877.910 incl. 128.503 M 22x1,5x10</p> <p>b) 878.040 incl. 128.503 M 22x1,5x10</p> <p>b) 128.503 0164.84 CU A 22x27x1,5</p>	<p>K:← 199.220 0514.C1 IWD RD FPM 70x14</p> <p>K:→ 199.230 0514.C2 IWD LD FPM 114x13</p> <p>N:← 419.730 0807.29 AW/BS RD FPM 55x70x8</p>	<p>TLS 714.810</p> 
<p>VAS 790.860 FPM 143.930 0956.44 FPM 8x</p>	<p>AAS 898.310 481.300 (4x) +481.320 (4x)</p>  <p>481.320 0349.H5 4x</p> 	<p>481.300 0348.N5 4x</p> 	<p>a) OWS 290.910 0164.68 +0164.69</p>  <p>a) 429.000 0304.54</p>  <p>b) 877.910 incl. 128.503 M 22x1,5x10</p> <p>b) 878.040 incl. 128.503 M 22x1,5x10</p> <p>b) 128.503 0164.84 CU A 22x27x1,5</p>	<p>K:← 199.220 0514.C1 IWD RD FPM 70x14</p> <p>K:→ 199.230 0514.C2 IWD LD FPM 114x13</p> <p>N:← 419.730 0807.29 AW/BS RD FPM 55x70x8</p>	
<p>VAS 424.820 FPM 403.730 0956.40 0956.38 FPM 24x</p>			<p>a) 036.164 Dirko HT / EU</p> <p>a) 510.031 Dirko HT / USA/CDN/MEX</p> <p>a) 527.291 Dirko HT / RU</p> <p>a) 648.661 Dirko HT / BR</p> <p>b) 434.941 M 16x1,5x12 incl. 813.052</p> <p>b) 834.823 0164.88 NBR A 16,7x24x1,5 FE/NBR</p>	<p>K:← 148.230 0514.82 AS RD FPM/ACM 42x56x6,5</p> <p>K:→ 509.930 0119.14 ASW LD FPM/ACM 98x120x7</p> <p>N:← 135.140 0807.24 ASW RD FPM 38x50x6 4x</p>	

<p>CITROËN</p> 				
<p>XFU (ES9A) XFV (ES9A)</p> <p>6 Cyl. 2946 ccm Cyl. 87,0 Ø</p> <p>C5 09/2004 →</p> <p>C6 09/2005 → 12/2012</p>		<p>123.022 0209.OX 0,74 mm $\frac{\pm}{\pm}$ L</p>  <p>123.032 0209.OY 0,74 mm $\frac{\pm}{\pm}$ R</p> 	<p>ZKS 152.570 ● 0204.86 (8x) M 10x1,5x148 2x</p> 	
<p>XFZ (ES9J4)</p> <p>6 Cyl. 2946 ccm Cyl. 87,0 Ø</p> <p>Xantia 01/1997 → 04/2003</p> <p>XM 04/1997 → 10/2000</p>		<p>123.651 0209.ON 1,45 mm $\frac{\pm}{\pm}$ 89 Ø</p>  <p>123.671 ● 0209.OQ 1,65 mm $\frac{\pm}{\pm}$ 89 Ø</p>  <p>L 1 ⊗</p> <p>123.661 0209.OP 1,45 mm $\frac{\pm}{\pm}$ 89 Ø</p>  <p>R</p> <p>123.681 ● 0209.OR 1,65 mm $\frac{\pm}{\pm}$ 89 Ø</p>  <p>R 1 ⊗</p>	<p>ZKS 152.570 ● 0204.86 (8x) M 10x1,5x148 2x</p> 	
<p>DT20C X8C (DT20C)</p> <p>6 Cyl. 2993 ccm Cyl. 84,0 Ø</p> <p>C5 HDI 04/2009 → 10/2014</p> <p>C6 HDI 04/2009 → 12/2012</p>	<p>CS* 712.830 OKS 840.120 OKS 858.670</p>			<p>584.890 0249.E1 2x</p> 
<p>F1CE0481 (30DT) F1CE0481D (F30DT)</p> <p>4 Cyl. 2999 ccm Cyl. 95,8 Ø</p> <p>Jumper HDI 09/2006 →</p>	<p>S⊕* 586.540 0197.AR</p>  <p>ES⊕ 586.530 0197.AQ</p> 	<p>589.110 0209.FJ 1,10 mm $\frac{\pm}{\pm}$ 95,8 Ø</p>  <p>340.260 1,20 mm $\frac{\pm}{\pm}$ 95,8 Ø</p>  <p>590.080 1,30 mm $\frac{\pm}{\pm}$ 95,8 Ø</p> 	<p>ZKS 877.740</p>	<p>351.260 0249.F7</p>  <p>452.640 1982.G0 4x</p> <p>390.600 1982.H7 4x</p>

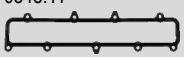
			<p>a) </p> <p>b) </p>	<p>K: </p> <p>N: </p>	
<p>VAS 424.820 FPM</p> <p>403.730 0956.40 0956.38 FPM 24x</p>			<p>a) 036.164 Dirko HT / EU</p> <p>a) 510.031 Dirko HT / USA/CDN/MEX</p> <p>a) 527.291 Dirko HT / RU</p> <p>a) 648.661 Dirko HT / BR</p> <p>b) 434.941 M 16x1,5x12 incl. 813.052</p> <p>b) 834.823 0164.88 NBR A 16,7x24x1,5 FE/NBR</p>	<p>K:← 148.230 0514.82 AS RD FPM/ACM 42x56x6,5</p> <p>K:→ 509.930 0119.14 ASW LD FPM/ACM 98x120x7</p> <p>N:← 135.140 0807.24 ASW RD FPM 38x50x6 4x</p>	
<p>VAS 424.820 FPM</p> <p>403.730 0956.40 0956.38 FPM 24x</p>			<p>a) 036.164 Dirko HT / EU</p> <p>a) 510.031 Dirko HT / USA/CDN/MEX</p> <p>a) 527.291 Dirko HT / RU</p> <p>a) 648.661 Dirko HT / BR</p> <p>b) 434.941 M 16x1,5x12 incl. 813.052</p> <p>b) 834.823 0164.88 NBR A 16,7x24x1,5 FE/NBR</p>	<p>K:← 148.230 0514.82 AS RD FPM/ACM 42x56x6,5</p> <p>K:→ 509.930 0119.14 ASW LD FPM/ACM 98x120x7</p> <p>N:← 135.140 0807.24 ASW RD FPM 38x50x6 4x</p>	
<p>VAS 505.690 505.680 0956.53 FPM 24x</p>	<p>584.910 0349.L0 2x</p> 		<p>a) 655.400 0164.75 ↑</p>  <p>a) 655.420 0304.57</p> <p>b) 813.052 0164.30 CU C 16x22x2</p>	<p>K:← 374.680 0326.28 ASW RD PTFE/ACM 35x50x7</p> <p>K:→ 655.650 0119.20 SP LD PTFE 92</p> <p>N:← 339.280 0807.36 ASW WD FPM 26x45x8 2x</p>	
<p>718.210 0951.61 FPM 16x</p> 	<p>452.400 0349.L8</p> 	<p>351.270 0348.T7</p> 	<p>a) 548.200 0304.59</p>  <p>b) 128.503 0164.84 CU A 22x27x1,5</p>	<p>K:← 353.780 0514.C9 AW RD PTFE/ACM 50x70x11</p> <p>K:→ 353.090 0514.E4 SP LD FPM 90x120x13,65</p>	

CITROËN

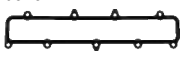

			<p>a) </p> <p>b) </p>	<p>K: </p> <p>N: </p>	
<p>718.210 0951.61 FPM 16x</p> 	<p>452.400 0349.L8</p> 	<p>351.270 0348.T7</p> 	<p>a) 548.200 0304.59</p>  <p>b) 128.503 0164.84 CU A 22x27x1,5</p>	<p>K:← 353.780 0514.C9 AW RD PTFE/ACM 50x70x11</p> <p>K:→ 353.090 0514.E4 SP LD FPM 90x120x13,65</p>	
<p>718.210 0951.61 FPM 16x</p> 	<p>452.400 0349.L8</p> 	<p>351.270 0348.T7</p> 	<p>a) 548.200 0304.59</p>  <p>b) 128.503 0164.84 CU A 22x27x1,5</p>	<p>K:← 353.780 0514.C9 AW RD PTFE/ACM 50x70x11</p> <p>K:→ 353.090 0514.E4 SP LD FPM 90x120x13,65</p>	

DACIA

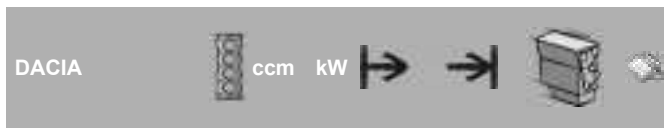

DACIA	ccm	kW				
Dokker	4	1197	85	11/2012		H5F 402 796 H5F 408
Dokker	4	1198	84	12/2012		H5F 402 796
Dokker	4	1332	96	03/2019		H5H 470 796
Dokker	4	1332	75	08/2019		H5H 470 796
Dokker	4	1461	55	11/2012		K9K 612 798 K9K 626
Dokker	4	1461	62	11/2012		K9K 838 800
Dokker	4	1461	63	11/2012		K9K 612 798 K9K 830 800
Dokker	4	1461	66	11/2012		K9K 612 798 K9K 626
Dokker	4	1598	61	11/2012		K7M 812 804 K7M 828
Dokker	4	1598	75	04/2015		H4M 738 802 H4M 740
Dokker	4	1598	80	08/2018		H4M 740 802
Duster	4	1197	92	10/2013		H5F 404 796 H5F 408 H5F 410
Duster	4	1332	96	01/2019		H5H 470 796 H5H 480
Duster	4	1332	110	01/2019		H5H 470 796 H5H 480
Duster	4	1461	63	04/2010	01/2018	K9K 796 800 K9K 830
Duster	4	1461	79	06/2010	01/2018	K9K 896 798 K9K 898
Duster	4	1461	66	10/2010		K9K 612 798 K9K 626 K9K 656 K9K 884 K9K 892 K9K 894
Duster	4	1461	81	10/2010	01/2018	K9K 658 798 K9K 856 K9K 858 K9K 896 K9K 898
Duster	4	1461	80	04/2013		K9K 656 798 K9K 658 K9K 666 K9K 667 K9K 856 K9K 858 K9K 898
Duster	4	1596	41	03/1988	12/1993	F8M 700 802

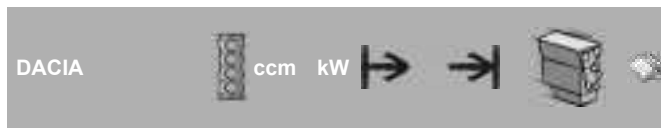

DACIA	ccm	kW				
Duster	4	1598	77	04/2010		K4M 606 802 K4M 616 K4M 642 K4M 690 K4M 694 K4M 696 K4M 842
Duster	4	1598	84	06/2015		H4M 430 802 H4M 438 H4M 730 H4M 738 H4M 740
Duster	4	1598	80	10/2017		H4M 740 802
Lodgy	4	1197	85	03/2012		H5F 402 796 H5F 408
Lodgy	4	1332	75	01/2019		H5H 470 796
Lodgy	4	1332	96	01/2019		H5H 470 796
Lodgy	4	1461	66	03/2012		K9K 612 798 K9K 626
Lodgy	4	1461	81	03/2012		K9K 666 798 K9K 846
Lodgy	4	1461	63	11/2012		K9K 612 798 K9K 830 800
Lodgy	4	1461	79	01/2013		K9K 846 798
Lodgy	4	1461	80	06/2015		K9K 666 798 K9K 846
Lodgy	4	1598	61	03/2012		K7M 812 804 K7M 828
Lodgy	4	1598	75	04/2015		H4M 740 802
Lodgy	4	1598	80	08/2018		H4M 740 802
Logan	3	898	66	10/2012		H4B 400 794 H4B 405 H4B 408 H4B 410
Logan	4	999	56	01/2011	10/2012	D4D 760 794
Logan	4	1149	55	02/2006		D4F 732 796 D4F 734
Logan	4	1149	53	02/2013		D4F 734 796
Logan	4	1149	54	05/2015		D4F 732 796
Logan	4	1390	55	09/2004		K7J 710 798 K7J 714
Logan	4	1461	48	09/2005		K9K 790 800 K9K 794
Logan	4	1461	50	01/2006		K9K 792 800
Logan	4	1461	63	09/2007		K9K 796 800 K9K 830 K9K 838
Logan	4	1461	55	05/2010		K9K 612 798 K9K 626 K9K 892

DACIA



DACIA	ccm	kW	→	→		
Logan	4	1461	65	05/2010		K9K 892 798
Logan	4	1461	66	10/2012		K9K 612 798 K9K 626
Logan	4	1598	64	08/2004		K7M 710 804 K7M 718
Logan	4	1598	77	02/2006		K4M 690 802 K4M 694 K4M 696 K4M 697 K4M 698 K4M 842
Logan	4	1598	62	05/2010		K7M 718 804 K7M 800 K7M 812 K7M 818
Logan	4	1598	63	06/2013	08/2016	K7M 812 804
Logan	4	1598	59	09/2016		K7M 812 804
Pick up	4	1870	47	02/2000	05/2008	F8Q 636 804
Pick up	4	1870	46	01/2004	12/2006	F8Q 636 804
Sandero	3	898	66	10/2012		H4B 400 794 H4B 408 H4B 410
Sandero	4	999	56	01/2011	12/2012	D4D 760 794
Sandero	3	999	49	01/2021		B4D 419 794
Sandero	4	1149	55	11/2008		D4F 732 796 D4F 734
Sandero	4	1149	54	05/2015		D4F 732 796
Sandero	4	1390	55	06/2008		K7J 710 798 K7J 714
Sandero	4	1390	53	01/2009		K7J 714 798
Sandero	4	1461	48	11/2008		K9K 790 800
Sandero	4	1461	50	11/2008		K9K 792 800
Sandero	4	1461	63	11/2008		K9K 796 800 K9K 830
Sandero	4	1461	55	05/2010		K9K 612 798 K9K 626 800 K9K 838 K9K 892
Sandero	4	1461	65	05/2010		K9K 892 798
Sandero	4	1461	66	10/2012		K9K 612 798 K9K 626
Sandero	4	1598	64	06/2008		K7M 710 804 K7M 718 K7M 732
Sandero	4	1598	62	05/2010	06/2013	K7M 800 804 K7M 818
Sandero	4	1598	60	01/2011	12/2012	K7M 818 804

DACIA	ccm	kW	→	→		
Sandero	4	1598	77	01/2011		K4M 690 802 K4M 694 K4M 696
Sandero	4	1598	63	11/2012		K7M 812 804
Sandero	4	1598	59	09/2016		K7M 812 804
Solenza	4	1390	55	02/2003	10/2005	E7J 262 798
Solenza	4	1870	46	02/2003		F8Q 636 804
Supernova	4	1390	55	04/2000	03/2003	E7J 262 798

DACIA

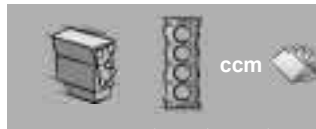

B4D 419	3	999	794
D4D 760	4	999	794
D4F 732	4	1149	796
D4F 734	4	1149	796
E7J 262	4	1390	798
F8M 700	4	1595	802
F8Q 630	4	1870	804
F8Q 636	4	1870	804
H4B 400	3	898	794
H4B 405	3	898	794
H4B 408	3	898	794
H4B 410	3	898	794
H4M 430	4	1598	802
H4M 438	4	1598	802
H4M 730	4	1598	802
H4M 738	4	1598	802
H4M 740	4	1598	802
H5F 402	4	1197	796
H5F 404	4	1197	796
H5F 408	4	1197	796
H5F 410	4	1197	796
H5H 470	4	1332	796
H5H 480	4	1332	796
K4M 606	4	1598	802
K4M 616	4	1598	802
K4M 642	4	1598	802
K4M 690	4	1598	802
K4M 694	4	1598	802
K4M 696	4	1598	802
K4M 697	4	1598	802
K4M 698	4	1598	802
K4M 842	4	1598	802
K4M 845	4	1598	802
K7J 710	4	1390	798
K7J 714	4	1390	798
K7M 690	4	1598	804
K7M 710	4	1598	804

K7M 718	4	1598	804
K7M 732	4	1598	804
K7M 800	4	1598	804
K7M 812	4	1598	804
K7M 818	4	1598	804
K7M 828	4	1598	804
K9K 612	4	1461	798
K9K 626	4	1461	798
K9K 656	4	1461	798
K9K 657	4	1461	798
K9K 658	4	1461	798
K9K 666	4	1461	798
K9K 667	4	1461	798
K9K 790	4	1461	800
K9K 792	4	1461	800
K9K 794	4	1461	800
K9K 796	4	1461	800
K9K 830	4	1461	800
K9K 838	4	1461	800
K9K 846	4	1461	798
K9K 856	4	1461	798
K9K 858	4	1461	798
K9K 884	4	1461	798
K9K 892	4	1461	798
K9K 894	4	1461	798
K9K 896	4	1461	798
K9K 898	4	1461	798

DACIA









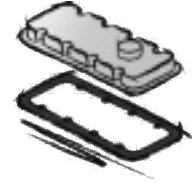
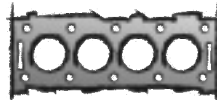
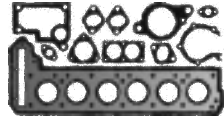







DACIA

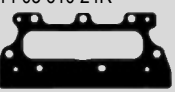

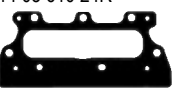
Das Original

DACIA



			<p>a) </p> <p>b) </p>	<p>K: </p> <p>N: </p>	
<p>020.020 13 20 764 85R ACM 12x</p>	<p>778.420 14 03 610 24R</p> 	<p>697.600 14 03 591 50R 3x</p>	<p>a) 036.164 Dirko HT / EU</p> <p>a) 510.031 Dirko HT / USA/CDN/MEX</p> <p>a) 527.291 Dirko HT / RU</p> <p>a) 648.661 Dirko HT / BR</p> <p>b) 813.052 77 03 062 023 CU C 16x22x2</p>	<p>K:← 697.530 13 51 060 67R ASW RD PTFE 40x52x7</p> <p>K:← 854.180 AS RD FPM 40x52x6</p> <p>K:→ 471.060 77 01 065 057 ASW LD FPM 84x117x7,5 →07/2014</p> <p>K:→ 697.520 12 27 933 04R ASW LD PTFE 84x117x7,5 07/2014→</p>	<p>TLS 779.140</p> 
<p>020.020 13 20 764 85R ACM 12x</p>	<p>778.420 14 03 610 24R</p> 	<p>697.600 14 03 591 50R 3x</p>	<p>a) 036.164 Dirko HT / EU</p> <p>a) 510.031 Dirko HT / USA/CDN/MEX</p> <p>a) 527.291 Dirko HT / RU</p> <p>a) 648.661 Dirko HT / BR</p> <p>b) 813.052 77 03 062 023 CU C 16x22x2</p>	<p>K:← 697.530 13 51 060 67R ASW RD PTFE 40x52x7</p> <p>K:← 854.180 AS RD FPM 40x52x6</p> <p>K:→ 697.520 12 27 933 04R ASW LD PTFE 84x117x7,5</p>	<p>TLS 779.140</p> 
<p>995.530 13 20 747 30R FPM 12x</p>	<p>875.620 20 81 348 76R</p> 	<p>870.780 82 01 695 837 3x</p> 	<p>a) 036.164 Dirko HT / EU</p> <p>a) 510.031 Dirko HT / USA/CDN/MEX</p> <p>a) 527.291 Dirko HT / RU</p> <p>a) 648.661 Dirko HT / BR</p> <p>a) 872.110 15 05 656 34R</p>  <p>b) 434.941 M 16x1,5x12 incl. 813.052</p> <p>b) 834.823 82 00 641 648 NBR A 16,7x24x1,5 FE/NBR</p>	<p>K:← 926.150 13 51 023 79R ASW OF RD FPM 40x52x6,9</p> <p>K:→ 928.270 12 27 929 67R ASW OF LD FPM 69x89x9</p>	
<p>VAS 222.810 FPM →08/2003</p> <p>VAS 522.940 FPM 08/2003→</p> <p>222.800 FPM →08/2003 16x</p> <p>522.930 82 00 171 215 FPM 08/2003→ 16x</p>	<p>165.510 82 00 310 867</p> 	<p>522.230 77 01 475 823 4x</p> 	<p>a) 030.793 Dirko HT</p> <p>b) 813.052 77 03 062 023 CU C 16x22x2</p>	<p>K:← 169.620 77 01 473 494 ASW RD PTFE/FPM 32x44x6</p> <p>K:→ 169.650 77 01 473 493 ASW LD PTFE/FPM 70x86x7</p> <p>N:← 159.714 77 01 473 495 ASW RD PTFE/ACM 28x47x8</p>	

DACIA

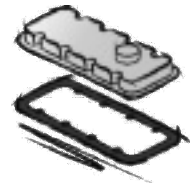
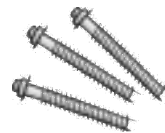
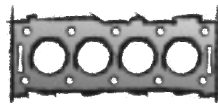
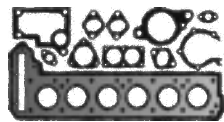

D4F 732/734

4 Cyl. **1149 ccm**
Cyl. 69,0 Ø

Logan
02/2006 →
Sandero
11/2008 →

ES⊕ **505.050**
77 01 475 822
CS* **262.980**
77 01 473 503



177.230
82 00 151 984

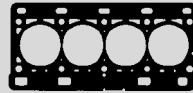

ZKS **258.270**
77 01 473 543
M 9x1,25x123

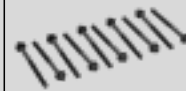

522.950
77 01 059 314



928.870
77 01 473 164
4x



H5F 402/404/408

4 Cyl. **1197 ccm**
Cyl. 72,2 Ø

Dokker
11/2012 →
Duster
10/2013 →
Lodgy
03/2012 →

ES⊕ **564.880**
10 10 153 03R
CS* **779.310**
10 10 162 36R
→07/2014
CS* **794.950**
10 10 158 85R
07/2014→
OKS **642.490**
21 30 427 26R



598.620
11 04 497 45R

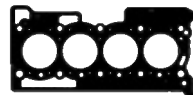

ZKS **649.390**
11 05 674 48R
M 10x1,5x123

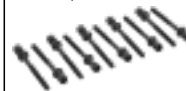

599.170
13 27 094 16R



H5F 410

4 Cyl. **1197 ccm**
Cyl. 72,2 Ø

Duster
06/2015 →

ES⊕ **564.880**
10 10 153 03R
CS* **794.950**
10 10 158 85R
OKS **642.490**
21 30 427 26R



598.620
11 04 497 45R

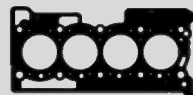

ZKS **649.390**
11 05 674 48R
M 10x1,5x123

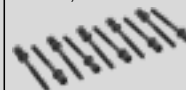

599.170
13 27 094 16R

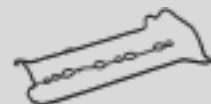

H5H 470/480

4 Cyl. **1332 ccm**
Cyl. 72,2 Ø

Dokker
03/2019 →
Duster
01/2019 →
Lodgy
01/2019 →

ES⊕ **464.560**
CS* **464.900**

464.450
11 04 466 34R
0,75 mm ± 72,9 Ø

ZKS **711.800**
82 01 719 850 (10x)
M 10x1,5x120



036.164
Dirko HT / EU
510.031
Dirko HT / USA/CDN/MEX
527.291
Dirko HT / RU
648.661
Dirko HT / BR
464.630
82 01 721 558

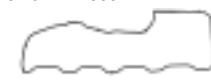







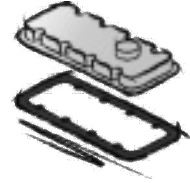
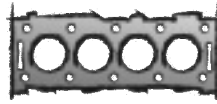
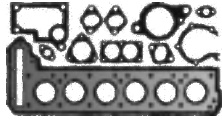









DACIA

			<p>a) </p> <p>b) </p>	<p>K: </p> <p>N: </p>	
<p>VAS 522.940 FPM 522.930 82 00 171 215 FPM 16x</p>	<p>165.510 82 00 310 867 </p>	<p>522.230 77 01 475 823 4x </p>	<p>a) 050.191 77 00 866 465 FE </p> <p>b) 813.052 77 03 062 023 CU C 16x22x2</p>	<p>K:← 169.620 77 01 473 494 ASW RD PTFE/FPM 32x44x6</p> <p>K:→ 169.650 77 01 473 493 ASW LD PTFE/FPM 70x86x7</p> <p>N:← 159.714 77 01 473 495 ASW RD PTFE/ACM 28x47x8</p>	
<p>020.020 13 20 764 85R ACM 16x</p>	<p>774.890 14 03 684 45R </p>	<p>590.260 14 03 550 49R 4x </p>	<p>a) 036.164 Dirko HT / EU</p> <p>a) 510.031 Dirko HT / USA/CDN/MEX</p> <p>a) 527.291 Dirko HT / RU</p> <p>a) 648.661 Dirko HT / BR</p> <p>b) 813.052 77 03 062 023 CU C 16x22x2</p>	<p>K:← 697.530 13 51 060 67R ASW RD PTFE 40x52x7</p> <p>K:← 854.180 AS RD FPM 40x52x6</p> <p>K:→ 471.060 77 01 065 057 ASW LD FPM 84x117x7,5 →07/2014</p> <p>K:→ 697.520 12 27 933 04R ASW LD PTFE 84x117x7,5 07/2014→</p>	TLS 794.960
<p>020.020 13 20 764 85R ACM 16x</p>	<p>774.890 14 03 684 45R </p>	<p>590.260 14 03 550 49R 4x </p>	<p>a) 036.164 Dirko HT / EU</p> <p>a) 510.031 Dirko HT / USA/CDN/MEX</p> <p>a) 527.291 Dirko HT / RU</p> <p>a) 648.661 Dirko HT / BR</p> <p>b) 813.052 77 03 062 023 CU C 16x22x2</p>	<p>K:← 697.530 13 51 060 67R ASW RD PTFE 40x52x7</p> <p>K:← 854.180 AS RD FPM 40x52x6</p> <p>K:→ 697.520 12 27 933 04R ASW LD PTFE 84x117x7,5</p>	TLS 794.960
<p>VAS 471.240 4x</p>	<p>464.590 14 03 675 94R</p>	<p>464.640 82 01 721 557 4x </p> <p>464.630 82 01 721 558 </p>	<p>a) 036.164 Dirko HT / EU</p> <p>a) 510.031 Dirko HT / USA/CDN/MEX</p> <p>a) 527.291 Dirko HT / RU</p> <p>a) 648.661 Dirko HT / BR</p> <p>b) 813.052 77 03 062 023 CU C 16x22x2</p>	<p>K:← 697.530 13 51 060 67R ASW RD PTFE 40x52x7</p> <p>K:← 854.180 AS RD FPM 40x52x6</p> <p>K:→ 697.520 12 27 933 04R ASW LD PTFE 84x117x7,5 07/2014→</p>	TLS 465.630





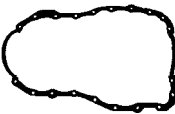



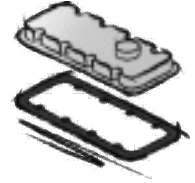
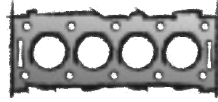
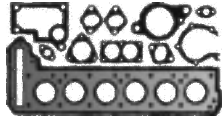





DACIA

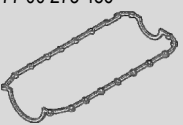

			<p>a) </p> <p>b) </p>	<p>K: </p> <p>N: </p>	
<p>VAS 825.042 FPM 701.289 77 00 736 465 FPM 8x</p>	<p>773.582 77 00 867 360</p> 	<p>331.781 77 01 471 932 4x</p> 	<p>b) 813.052 77 03 062 023 CU C 16x22x2</p>	<p>K:← 504.483 77 00 854 842 AW RD FPM/ACM 35x47x7 K:→ 507.822 77 00 859 692 ASW LD FPM/ACM 80x100x8 N:← 505.838 77 00 749 395 ASW RD FPM 30x42x7</p>	
<p>VAS 825.042 FPM 701.289 77 00 736 465 FPM 8x</p>	<p>773.582 77 00 867 360</p> 	<p>331.781 77 01 471 932 4x</p> 	<p>a) 263.380 77 00 273 486</p>  <p>b) 434.941 M 16x1,5x12 incl. 813.052</p> <p>b) 813.052 77 03 062 023 CU C 16x22x2</p> <p>b) 834.823 82 00 641 648 NBR A 16,7x24x1,5 FE/NBR</p>	<p>K:← 504.483 77 00 854 842 AW RD FPM/ACM 35x47x7 K:→ 507.822 77 00 859 692 ASW LD FPM/ACM 80x100x8 N:← 505.838 77 00 749 395 ASW RD FPM 30x42x7</p>	
<p>403.730 77 00 109 840 FPM 8x</p>	<p>332.280 82 00 414 346</p> 		<p>a) 380.960 82 00 379 654</p>  <p>b) 434.941 M 16x1,5x12 incl. 813.052</p> <p>b) 834.823 82 00 641 648 NBR A 16,7x24x1,5 FE/NBR</p>	<p>K:← 431.420 77 01 475 009 ASW RD PTFE/ACM 35x47x7 K:→ 745.740 77 01 473 544 ASW LD PTFE/ACM 80x100x9 N:← 073.890 77 01 471 376 AS RD FPM 28x42x5 N:← 584.880 82 00 079 247 ASW RD PTFE/ACM 28x42x6</p>	<p>TLS 518.760</p>
<p>403.730 77 00 109 840 FPM 8x</p>	<p>332.280 82 00 414 346</p> 		<p>a) 380.960 82 00 379 654</p>  <p>b) 434.941 M 16x1,5x12 incl. 813.052</p> <p>b) 834.823 82 00 641 648 NBR A 16,7x24x1,5 FE/NBR</p>	<p>K:← 431.420 77 01 475 009 ASW RD PTFE/ACM 35x47x7 K:→ 745.740 77 01 473 544 ASW LD PTFE/ACM 80x100x9 N:← 073.890 77 01 471 376 AS RD FPM 28x42x5 N:← 584.880 82 00 079 247 ASW RD PTFE/ACM 28x42x6</p>	



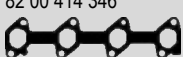





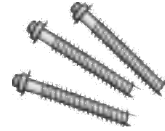
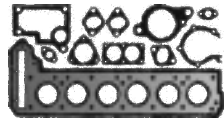



DACIA

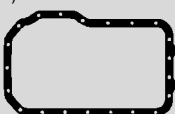

			<p>a) </p> <p>b) </p>	<p>K: </p> <p>N: </p>	
<p>403.730 77 00 109 840 FPM 8x</p>	<p>332.280 82 00 414 346</p> 		<p>a) 263.380 77 00 273 486</p>  <p>b) 434.941 M 16x1,5x12 incl. 813.052</p> <p>b) 834.823 82 00 641 648 NBR A 16,7x24x1,5 FE/NBR</p>	<p>K:← 431.420 77 01 475 009 ASW RD PTFE/ACM 35x47x7</p> <p>K:→ 745.740 77 01 473 544 ASW LD PTFE/ACM 80x100x9</p> <p>N:← 073.890 77 01 471 376 AS RD FPM 28x42x5</p>	<p>TLS 714.860</p> 
<p>403.730 77 00 109 840 FPM 8x</p>	<p>332.280 82 00 414 346</p> 		<p>a) 380.960 82 00 379 654</p>  <p>b) 434.941 M 16x1,5x12 incl. 813.052</p> <p>b) 834.823 82 00 641 648 NBR A 16,7x24x1,5 FE/NBR</p>	<p>K:← 431.420 77 01 475 009 ASW RD PTFE/ACM 35x47x7</p> <p>K:→ 745.740 77 01 473 544 ASW LD PTFE/ACM 80x100x9</p> <p>N:← 073.890 77 01 471 376 AS RD FPM 28x42x5</p>	<p>TLS 714.351</p> 
<p>403.730 77 00 109 840 FPM 8x</p>	<p>332.280 82 00 414 346</p> 		<p>a) 380.960 82 00 379 654</p>  <p>b) 434.941 M 16x1,5x12 incl. 813.052</p> <p>b) 834.823 82 00 641 648 NBR A 16,7x24x1,5 FE/NBR</p>	<p>K:← 431.420 77 01 475 009 ASW RD PTFE/ACM 35x47x7</p> <p>K:→ 745.740 77 01 473 544 ASW LD PTFE/ACM 80x100x9</p> <p>N:← 073.890 77 01 471 376 AS RD FPM 28x42x5</p>	

DACIA



			<p>a) </p> <p>b) </p>	<p>K: </p> <p>N: </p>	
<p>VAS 294.250 FPM 294.110 77 00 737 124 FPM 8x</p>	<p>⇒</p>	<p>421.432 77 00 854 867</p> 	<p>a) 984.478</p>  <p>b) 813.052 77 03 062 023 CU C 16x22x2</p>	<p>K:← 508.470 ASW RD FPM/ACM 50x68x8 K:→ 508.462 77 03 087 190 ASW LD FPM/ACM 85x105x8 K:→ 711.720 77 03 087 224 ASW LD FPM/ACM 85x105x11 N:← 508.544 77 03 087 192 ASW RD FPM 25x42x7</p>	
<p>904.900 13 20 7CJ 40A FPM 16x</p>	<p>792.220 14 03 61K T0A</p>	<p>801.650 14 03 286 98R 4x</p> 	<p>a) 036.164 Dirko HT / EU a) 510.031 Dirko HT / USA/CDN/MEX a) 527.291 Dirko HT / RU a) 648.661 Dirko HT / BR b) 776.327 77 01 474 516 CU PR 11x17,5x3</p>	<p>K:← 854.180 AS RD FPM 40x52x6 K:→ 471.060 77 01 065 057 ASW LD FPM 84x117x7,5</p>	
<p>151.810 77 00 103 938 FPM 16x</p>	<p>584.940 82 00 365 915</p> 	<p>339.550 82 00 066 662</p> 	<p>a) 263.380 77 00 273 486</p>  <p>b) 434.941 M 16x1,5x12 incl. 813.052 b) 834.823 82 00 641 648 NBR A 16,7x24x1,5 FE/NBR</p>	<p>K:← 504.483 77 00 854 842 AW RD FPM/ACM 35x47x7 K:→ 507.822 77 00 859 692 ASW LD FPM/ACM 80x100x8 N:← 073.890 77 01 471 376 AS RD FPM 28x42x5 2x</p>	

DACIA

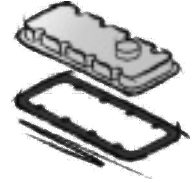
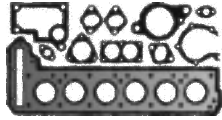

**K7M 690/710/718/732/800/
812/818/828**

4 Cyl. **1598 ccm**
Cyl. 79,5 Ø

Dokker

11/2012 →

Lodgy

03/2012 →

Logan

08/2004 →

Sandero

06/2008 →

S⊕* **867.570**
ES⊕ **458.730**
77 01 475 899
CS* **271.210**

431.551
82 00 269 969
0,30 mm $\frac{1}{32}$ 80,3 Ø



ZKS **759.371**
60 01 543 378 (5x)
+60 01 543 379 (5x)
M 10x1,5x93/107,5

773.700
77 01 471 719



F8Q 630/636



4 Cyl. **1870 ccm**
Cyl. 80,0 Ø

Pick up

02/2000 → 05/2008

Solenza

02/2003 →

S⊕* **309.311**

S⊕* **927.300**

ES⊕ **984.285**

CS* **906.550**
77 01 470 176

219.691
82 00 188 390
1,39 mm $\frac{1}{16}$ 81 Ø
2 ⊗



219.721
82 00 188 114
1,48 mm $\frac{1}{16}$ 81 Ø
1 ⊗



219.861
82 00 188 391
1,59 mm $\frac{1}{16}$ 81 Ø
3 ⊗













ZKS **111.460**
M 12x1,5x119

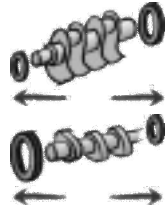

892.009
77 00 719 666

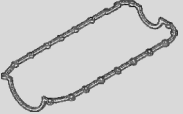

			<p>a) </p> <p>b) </p>	<p>K: </p> <p>N: </p>	
<p>VAS 825.042 FPM 701.289 77 00 736 465 FPM 8x</p>	<p>773.582 77 00 867 360</p> 	<p>331.781 77 01 471 932 4x</p> 	<p>a) 263.380 77 00 273 486</p>  <p>b) 434.941 M 16x1,5x12 incl. 813.052</p> <p>b) 813.052 77 03 062 023 CU C 16x22x2</p> <p>b) 834.823 82 00 641 648 NBR A 16,7x24x1,5 FE/NBR</p>	<p>K:← 504.483 77 00 854 842 AW RD FPM/ACM 35x47x7</p> <p>K:→ 507.822 77 00 859 692 ASW LD FPM/ACM 80x100x8</p> <p>N:← 505.838 77 00 749 395 ASW RD FPM 30x42x7</p>	
<p>VAS 294.250 FPM 294.110 77 00 737 124 FPM 8x</p>	<p>⇒</p>	<p>421.432 77 00 854 867</p> 	<p>a) 138.430 77 00 114 424</p>  <p>b) 434.941 M 16x1,5x12 incl. 813.052</p> <p>b) 813.052 77 03 062 023 CU C 16x22x2</p> <p>b) 834.823 82 00 641 648 NBR A 16,7x24x1,5 FE/NBR</p>	<p>K:← 157.200 77 00 103 245 ASW RD FPM 42x54x6</p> <p>K:→ 508.462 77 03 087 190 ASW LD FPM/ACM 85x105x8</p> <p>K:→ 711.720 77 03 087 224 ASW LD FPM/ACM 85x105x11</p> <p>N:← 508.544 77 03 087 192 ASW RD FPM 25x42x7</p>	





DAIHATSU







DAIHATSU	ccm	kW	→	→	→	→
1000	3	993	33	07/1986	10/1997	CB 10 812
1300	4	1295	48	06/1998		HC-E 814
Applause	4	1590	66	06/1989	07/1997	HD 816
Applause	4	1590	77	06/1989	07/1997	HD-E 818
Applause	4	1590	73	07/1997	05/2000	HD-E 818
Atrai	4	1298	68	07/2000	09/2003	K3-VE 816
Bego	4	1298	63	11/2005		K3-VE 816
Ceria	3	847	27	01/2001	12/2006	ED 10 810
Charade	3	993	37	10/1977	02/1981	CB 20 812
Charade	3	993	38	02/1981	03/1996	CB 20 CB 22 CB 23 812
Charade	3	993	27	10/1983	12/1992	CL 10 812 CL 11
Charade	3	993	35	03/1987	12/1992	CL 812
Charade	3	993	41	04/1989	12/1992	CB 90 812
Charade	3	993	40	11/1990	12/1992	CB 90 812
Charade	3	993	42	03/1993	03/1996	CB 20 812
Charade	4	1295	56	09/1988	01/1992	HC-C 814
Charade	4	1295	58	09/1988	12/1992	HC 814
Charade	4	1296	66	06/1988	02/1993	HC-E 814
Charade	4	1296	62	01/1993	09/2000	HC 814 HC-E
Charade	4	1296	55	05/1996	11/1999	HC-E 814
Charade	4	1296	44	09/1996	11/1999	HC 814 HC-U
Charade	4	1499	55	06/1994	01/2001	HEE 816 HEEG
Charade	4	1499	66	06/1994	11/1999	HEE 816 HEEG
Charade	4	1589	77	03/1993	03/1996	HD-E 818
Charade	4	1590	69	03/1993	04/1997	HD-E 818
Charade	4	1590	77	03/1993	11/1999	HD-E 818
City Breeze	4	1295	55	06/1998		HC-E 814
City Breeze	4	1295	54	09/1999	08/2003	HC-C 814
Classy	4	1295	56	01/1990	12/1998	HC-C 814
Coo	3	989	40	10/2006		EJ-DE 810
Coo	3	989	43	10/2006		EJ-VE 810
Coo	4	1298	67	10/2006		K3-VE 816
Coo Turbo	4	1298	95	10/2006		K3-VET 816

DAIHATSU	ccm	kW	→	→	→	→
Copen	4	1298	64	03/2006	09/2012	K3-VE 816
Cuore	3	847	32	09/1985	08/1998	ED 10 810 ED 10 ED 20
Cuore	3	847	29	11/1989	12/1990	ED 10 810
Cuore	3	847	30	10/1990	12/1994	ED 10 K 810
Cuore	3	847	31	11/1996	10/1998	ED 20 810
Cuore	3	989	40	11/1998	09/2000	EJ-DE 810
Cuore	3	989	41	11/1998	12/2002	EJ-DE 810 EJ-VE
Cuore	3	989	43	10/2000		EJ-VE 810
Cuore	3	998	51	04/2007		1KR-FE 814
Extol	4	1298	63	07/2000	11/2011	K3-VE 816
Extol	4	1298	66	07/2000		K3-VE 816
Extol	4	1298	68	10/2003	12/2005	K3-VE 816
Feroza	4	1590	63	10/1988	12/1999	HD-C 818
Feroza	4	1590	70	10/1988	12/1999	HD-E 818
Feroza	4	1590	67	10/1991	12/1999	HD-C 818
Feroza	4	1590	62	09/1993	12/1997	HD-C 818
Gran Move	4	1499	55	10/1996	08/1998	HEE 816 HEEG
Gran Move	4	1499	66	10/1996	10/1998	HEEG 816
Gran Move	4	1499	71	10/1996	08/1998	HEEG 816
Gran Move	4	1589	67	05/1998		HD-EP 818
Gran Move	4	1589	77	06/1998	07/2002	HD-EP 818
Gran Move	4	1589	70	07/1998	07/2002	HD-EP 818
Gran Move	4	1590	67	05/1998		HD-EP 818
Handi	3	989	41	07/1998	09/2000	EJ-DE 810
Handivan	3	847	26	03/1986	06/1990	ED 10 K 810
Hijet	3	993	33	09/1983	05/1998	CB 812 CB 10 CB41
Hijet	3	993	34	12/1992	09/1994	CB41 812
Hijet	3	993	35	07/1994	05/1998	CB42 812
Hijet	4	1295	48	05/1998		HC-E 814
Hijet	4	1295	52	06/1998		HC-E 814
Hijet	4	1589	60	10/1994	12/1995	HD-C 818
Materia	3	989	40	10/2006		EJ-DE 810
Materia	3	989	43	10/2006		EJ-VE 810
Materia	4	1298	67	10/2006		K3-VE 816



DAIHATSU		ccm	kW				
Materia Turbo	4	1298	95	10/2006		K3-VET	816
Mira	3	847	32	11/1990	12/1992	ED 10	810
Mira Gino	3	847	31	08/1998	09/2003	ED 20	810
Move	3	847	31	01/1997	11/1999	ED 20	810
Move	3	989	45	05/1997	11/1999	EJ-DE	810
Move	3	989	40	10/1998	12/2000	EJ-VE	810
Move	3	989	41	10/1998	09/2002	EJ-DE	810
Rocky	4	1589	70	09/1989	12/1992	HD-E	818
Rocky	4	1590	77	01/1990	12/1997	HD-E	818
Rocky	4	1590	62	09/1993	12/1997	HD-C	818
Rush	4	1298	63	11/2005		K3-VE	816
Sirion	3	989	40	04/1998	10/2000	EJ-DE	810
Sirion	3	989	41	04/1998	09/2000	EJ-DE	810
Sirion	3	989	43	09/2000	01/2005	EJ-VE	810
Sirion	3	998	51	01/2005		1KR-FE	814
Sirion	4	1298	75	08/2000	03/2005	K3-VE2	816
Sirion	4	1298	81	06/2002	03/2005	K3-VE2	816
Sirion	4	1298	64	01/2005		K3-VE	816
Sirion	4	1298	67	03/2008		K3-VE	816
Sirion	4	1298	66	07/2011		K3-VE	816
Skywing	3	993	38	02/1987	02/1993	CB 22 CB 23	812
Skywing	3	993	40	11/1990	02/1993	CB 90	812
Social	4	1589	66	05/1989	06/1992	HD-C	818
Social	4	1589	77	05/1989	08/1997	HD-E	818
Sparcar	3	993	33	09/1983	05/1986	CB	812
Terios	4	1296	62	05/1997	12/1999	HC-EJ	814
Terios	4	1296	61	10/1997	10/2000	HC-EJ	814
Terios	4	1298	63	07/2000		K3-VE	816
Terios	4	1499	63	05/1999	10/2005	HEE	816
Terios	4	1589	66	05/1999	10/2005	HD-C	818
Terios Turbo	4	1298	103	10/2002	10/2005	K3-VET	816
Thor	3	998	51	11/2016		1KR-FE	814
Trevis	3	989	43	06/2006		EJ-VE	810
Xenia	3	989	41	01/2002		EJ-DE	810
Xenia	3	989	46	05/2007		EJ-DE EJ-VE	810
Xenia	4	1298	63	01/2002		K3-VE	816

DAIHATSU		ccm	kW				
Xenia	4	1298	68	05/2007		K3-VE	816
YRV	3	989	43	02/2001		EJ-VE	810
YRV	4	1298	64	02/2001		K3-VE	816
YRV	4	1298	95	07/2002		K3-VET	816
Zebra	3	993	33	07/1987	05/1998	CB 10 CB41	812
Zebra	4	1295	55	01/1989		HC-C HC-E	814
Zebra	4	1295	54	09/1999	08/2003	HC-C	814
Zebra	4	1499	61	01/2002	12/2007	HE-C	816

DAIHATSU











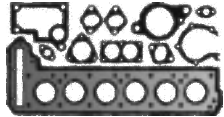
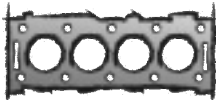

1KR-FE	3	998	814
CB	3	993	812
CB 10	3	993	812
CB 20	3	993	812
CB 22	3	993	812
CB 23	3	993	812
CB41	3	993	812
CB42	3	993	812
CB 51	3	993	812
CB 90	3	993	812
CL	3	993	812
CL 10	3	993	812
CL 11	3	993	812
CL 50	3	993	812
ED	3	847	810
ED 10	3	847	810
ED 10 K	3	847	810
ED 20	3	847	810
EJ	3	989	810
EJ-DE	3	989	810
EJ-VE	3	989	810
HC	4	1295	814
HC-C	4	1296	814
HC-E	4	1295	814
HC-EJ	4	1296	814
HC-U	4	1295	814
HD	4	1590	816
HD-C	4	1590	818
HD-E	4	1590	818
HD-EP	4	1590	818
HE-C	4	1499	816
HEE	4	1499	816
HEEG	4	1499	816
K3-VE	4	1298	816
K3-VE2	4	1298	816
K3-VET	4	1298	816

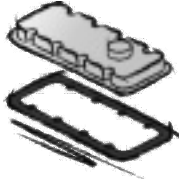





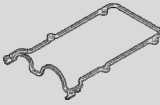
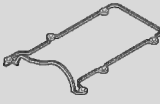



















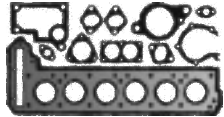
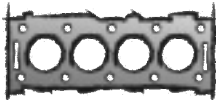

DAIHATSU

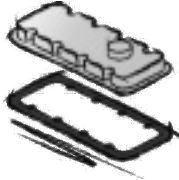

















Das Original





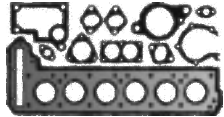
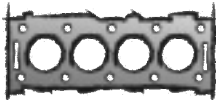

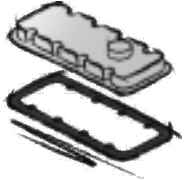
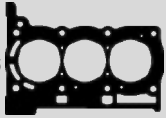
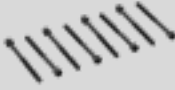

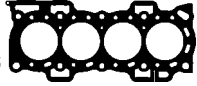
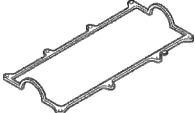
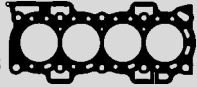
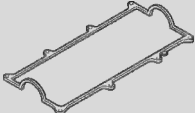







DAIHATSU 				
ED 10 ED 10 K 3 Cyl. 847 ccm Cyl. 66,0 Ø Ceria 01/2001 → 12/2006 Cuore 09/1985 → 12/1994 Handivan 03/1986 → 06/1990 Mira 11/1990 → 12/1992		069.490 11115-87212-000 1,35 mm $\frac{\pm}{\pm}$ 69 Ø 		069.530 11213-87203-000 
ED ED 20 3 Cyl. 847 ccm Cyl. 66,0 Ø Cuore 10/1990 → 10/1998 Mira Gino 08/1998 → 09/2003 Move 01/1997 → 11/1999		069.490 11115-87212-000 1,35 mm $\frac{\pm}{\pm}$ 69 Ø 		069.530 11213-87203-000 
EJ EJ-DE 3 Cyl. 989 ccm Cyl. 72,0 Ø Coo 10/2006 → Cuore 11/1998 → 12/2002 Handi 07/1998 → 09/2000 Materia 10/2006 → Move 05/1997 → 09/2002 Sirion 04/1998 → 10/2000 Xenia 01/2002 →	ES⊕ 428.780 04112-97206 08/1998→	090.860 11115-97201-000 1,30 mm $\frac{\pm}{\pm}$ 73,5 Ø 		091.110 11213-87211-000 Sirion M1 →08/1998  428.770 11213-97202 08/1998→ 
EJ-VE 3 Cyl. 989 ccm Cyl. 72,0 Ø Coo 10/2006 → Cuore 11/1998 → Materia 10/2006 → Move 10/1998 → 12/2000 Sirion 09/2000 → 01/2005 Trevis 06/2006 → Xenia 05/2007 → YRV 02/2001 →	ES⊕ 428.780 04112-97206	090.860 11115-97201-000 1,30 mm $\frac{\pm}{\pm}$ 73,5 Ø 		428.770 11213-97202 

			<p>a) </p> <p>b) </p>	<p>K: </p> <p>N: </p>	
<p>069.550 90048-12009-000 ACM 6x</p>	<p>069.670 17173-87204-000</p> 	<p>069.640 ● 17177-87213-000</p> 		<p>K:← 777.471 90043-11277-000 AS RD ACM 32x46x6</p> <p>K:→ 092.170 90043-11283-000 A LD FPM 58x74x10</p> <p>N:← 023.520 ASW RD FPM 38x52x6</p>	
<p>069.550 90048-12009-000 ACM 6x</p>	<p>069.670 17173-87204-000</p> 		<p>a) 036.164 Dirko HT / EU</p> <p>a) 510.031 Dirko HT / USA/CDN/MEX</p> <p>a) 527.291 Dirko HT / RU</p> <p>a) 648.661 Dirko HT / BR</p>	<p>K:← 777.471 90043-11277-000 AS RD ACM 32x46x6</p> <p>K:→ 092.170 90043-11283-000 A LD FPM 58x74x10</p> <p>N:← 023.520 ASW RD FPM 38x52x6</p>	
<p>091.180 90048-12021-000 FPM 12x</p>	<p>092.160 17173-87229-000</p> 	<p>451.260 17177-97202 Sirion M1 08/1998→</p> 	<p>a) 036.164 Dirko HT / EU</p> <p>a) 510.031 Dirko HT / USA/CDN/MEX</p> <p>a) 527.291 Dirko HT / RU</p> <p>a) 648.661 Dirko HT / BR</p> <p>b) 952.850 M 12x1,25x11</p> <p>b) 473.500 90430-12031 FI A 12x24x2</p>	<p>K:← 777.471 90043-11277-000 AS RD ACM 32x46x6 →Mot. 7679648</p> <p>K:→ 092.170 90043-11283-000 A LD FPM 58x74x10</p> <p>N:← 023.520 ASW RD FPM 38x52x6</p>	
<p>091.180 90048-12021-000 FPM 12x</p>	<p>092.160 17173-87229-000</p> 	<p>451.260 17177-97202</p> 	<p>a) 036.164 Dirko HT / EU</p> <p>a) 510.031 Dirko HT / USA/CDN/MEX</p> <p>a) 527.291 Dirko HT / RU</p> <p>a) 648.661 Dirko HT / BR</p> <p>b) 952.850 M 12x1,25x11</p> <p>b) 473.500 90430-12031 FI A 12x24x2</p>	<p>K:← 777.471 90043-11277-000 AS RD ACM 32x46x6 →Mot. 7679648</p> <p>K:→ 092.170 90043-11283-000 A LD FPM 58x74x10</p> <p>N:← 023.520 ASW RD FPM 38x52x6</p>	

<p>DAIHATSU</p> 				
<p>CB 20/22</p> <p>3 Cyl. 993 ccm Cyl. 76,0 Ø</p> <p>Charade 10/1977 → 03/1996</p> <p>Skywing 02/1987 → 02/1993</p>		<p>529.680 11115-87729 1,35 mm \pm 77,5 Ø 2 ▽</p> 		<p>578.428 11213-87705-000</p> 
<p>CB CB 10/23/51/90</p> <p>3 Cyl. 993 ccm Cyl. 76,0 Ø</p> <p>1000 07/1986 → 10/1997</p> <p>Charade 10/1983 → 12/1992</p> <p>Hijet 09/1983 → 10/1990</p> <p>Skywing 02/1987 → 02/1993</p> <p>Sparcar 09/1983 → 05/1986</p> <p>Zebra 07/1987 → 05/1998</p>		<p>529.680 11115-87729 1,35 mm \pm 77,5 Ø 2 ▽</p> 		<p>578.428 11213-87705-000</p> 
<p>CB41 CB42</p> <p>3 Cyl. 993 ccm Cyl. 76,0 Ø</p> <p>Hijet 12/1992 → 05/1998</p> <p>Zebra 07/1987 → 05/1998</p>	<p>ES⊕ 576.330 04112-87780</p>	<p>529.680 11115-87729 1,35 mm \pm 77,5 Ø 2 ▽</p> 		<p>578.428 11213-87705-000</p> 
<p>CL CL 10/11/50</p> <p>3 Cyl. 993 ccm Cyl. 76,0 Ø</p> <p>Charade 10/1983 → 12/1992</p>		<p>529.690 11115-87719 1,60 mm \pm 77,5 Ø</p> 		









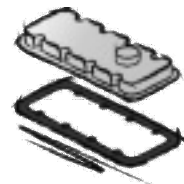
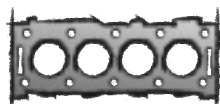
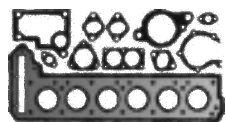



			<p>a) </p> <p>b) </p>	<p>K: </p> <p>N: </p>	
<p>069.550 90048-12009-000 ACM 6x</p>		<p>526.800 17177-87708</p> 		<p>K:← 576.320 90311-32106 AS RD FPM 32x48x7</p> <p>K:← 022.170 AS RD VMQ 34x48x7 07/1983→</p> <p>K:→ 092.170 90043-11283-000 A LD FPM 58x74x10</p> <p>N:← 576.320 90311-32106 AS RD FPM 32x48x7</p>	
<p>069.550 90048-12009-000 ACM 6x</p>		<p>526.800 17177-87708</p> 		<p>K:← 022.170 AS RD VMQ 34x48x7</p> <p>K:→ 092.170 90043-11283-000 A LD FPM 58x74x10</p> <p>N:← 576.320 90311-32106 AS RD FPM 32x48x7</p>	
<p>069.550 90048-12009-000 ACM 6x</p>	<p>521.090 17173-87719-000</p> 	<p>526.800 17177-87708</p> 		<p>K:← 022.170 AS RD VMQ 34x48x7</p> <p>K:→ 092.170 90043-11283-000 A LD FPM 58x74x10</p> <p>N:← 576.320 90311-32106 AS RD FPM 32x48x7</p>	
<p>069.550 90048-12009-000 ACM 6x</p>				<p>K:← 022.170 AS RD VMQ 34x48x7</p> <p>K:→ 092.170 90043-11283-000 A LD FPM 58x74x10</p>	





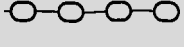
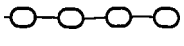



DAIHATSU 				
1KR-FE 3 Cyl. 998 ccm Cyl. 71,0 Ø Cuore 04/2007 → Sirion 01/2005 → Thor 11/2016 →	S⊕* 687.840 →05/2014 S⊕* 864.540 05/2014→ ES⊕ 687.800 →05/2014 ES 694.410 05/2014→ CS* 687.750 →05/2014	484.750 11115-40060 0,50 mm $\frac{\pm}{\text{mm}}$ 72 Ø  →05/2014 589.490 05/2014→	ZKS 728.090 90910-02151 (8x) M 9x1,5x120 →05/2014 	497.380 11213-B1020 →05/2014  586.210 05/2014→ 
HC HC-E/U 4 Cyl. 1295 ccm Cyl. 76,0 Ø 1300 06/1998 → Charade 06/1988 → 09/2000 City Breeze 06/1998 → Hijet 05/1998 → Zebra 06/1998 →	ES⊕ 069.320 04112-87112-000	069.331 11115-87106-000 1,35 mm $\frac{\pm}{\text{mm}}$ 77 Ø 		069.390 11213-87103-000 
HC-C/EJ 4 Cyl. 1296 ccm Cyl. 76,0 Ø Charade 09/1988 → 01/1992 City Breeze 09/1999 → 08/2003 Classy 01/1990 → 12/1998 Terios 05/1997 → 10/2000 Zebra 01/1989 → 10/2005	ES⊕ 069.320 04112-87112-000	069.331 11115-87106-000 1,35 mm $\frac{\pm}{\text{mm}}$ 77 Ø 		069.390 11213-87103-000 

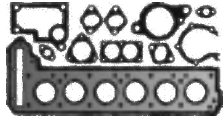
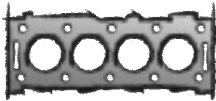

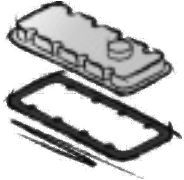

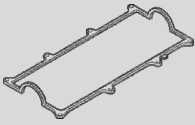

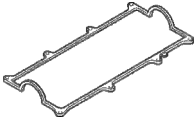

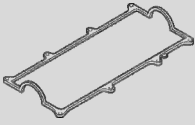



			<p>a) </p> <p>b) </p>	<p>K: </p> <p>N: </p>	
<p>VAS 338.870</p>	<p>291.540 17173-40020 →05/2014</p> 	<p>290.930 11213-97402 →05/2014</p>  <p>291.530 17178-B1020 →05/2014</p>  <p>586.480 05/2014→</p>  <p>642.680 05/2014→</p> 	<p>a) 036.164 Dirko HT / EU</p> <p>a) 510.031 Dirko HT / USA/CDN/MEX</p> <p>a) 527.291 Dirko HT / RU</p> <p>a) 648.661 Dirko HT / BR</p> <p>b) 877.960 M 12x1,25x22</p> <p>b) 473.500 90430-12031 FI A 12x24x2</p>	<p>K:← 694.300 AS RD FPM 38x50x6</p> <p>K:→ 458.620 90043-73004 90043-11402 AS LD FPM 73x89x8,5</p> <p>K:→ 848.390 AS LD FPM 73x89x8,5</p>	
<p>069.440 90048-12011-000 FPM 16x</p>	<p>069.470 17173-87104-000</p> 	<p>069.460 17177-87101-000</p> 	<p>b) 952.850 M 12x1,25x11</p> <p>b) 473.500 90430-12031 FI A 12x24x2</p>	<p>K:← 022.170 AS RD VMQ 38x48x7</p> <p>N:← 763.918 90043-11229-000 AW/BS RD FPM 38x50x8</p>	
<p>069.440 90048-12011-000 FPM 16x</p>	<p>069.470 17173-87104-000</p> 	<p>069.460 17177-87101-000</p> 	<p>b) 952.850 M 12x1,25x11</p> <p>b) 473.500 90430-12031 FI A 12x24x2</p>	<p>K:← 022.170 AS RD VMQ 34x48x7</p> <p>N:← 763.918 90043-11229-000 AW/BS RD FPM 38x50x8</p>	

DAIHATSU

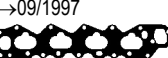

			<p>a) </p> <p>b) </p>	<p>K: </p> <p>N: </p>	
VAS 472.230	458.690 17173-97401 	458.790 17177-97402 	<p>a) 036.164 Dirko HT / EU</p> <p>a) 510.031 Dirko HT / USA/CDN/MEX</p> <p>a) 527.291 Dirko HT / RU</p> <p>a) 648.661 Dirko HT / BR</p> <p>b) 952.850 M 12x1,25x11</p> <p>b) 473.500 90430-12031 FI A 12x24x2</p>	<p>K:← 010.360 90311-35040 AS RD ACM 35x49x6</p> <p>K:→ 458.620 90043-73004 90043-11402 AS LD FPM 73x89x8,5</p> <p>K:→ 848.390 AS LD FPM 73x89x8,5</p>	
VAS 472.230		458.790 17177-97402 	<p>a) 036.164 Dirko HT / EU</p> <p>a) 510.031 Dirko HT / USA/CDN/MEX</p> <p>a) 527.291 Dirko HT / RU</p> <p>a) 648.661 Dirko HT / BR</p> <p>b) 952.850 M 12x1,25x11</p> <p>b) 473.500 90430-12031 FI A 12x24x2</p>	<p>K:← 010.360 90311-35040 AS RD ACM 35x49x6</p> <p>K:→ 458.620 90043-73004 90043-11402 AS LD FPM 73x89x8,5</p> <p>K:→ 848.390 AS LD FPM 73x89x8,5</p>	
069.440 90048-12011-000 FPM 16x	069.470 17173-87104-000 		<p>b) 952.850 M 12x1,25x11</p> <p>b) 473.500 90430-12031 FI A 12x24x2</p>	<p>K:← 022.170 AS RD VMQ 34x48x7</p> <p>N:← 763.918 90043-11229-000 AW/BS RD FPM 38x50x8</p>	
069.440 90048-12011-000 FPM 16x	069.470 17173-87104-000 	069.460 17177-87101-000 	<p>b) 952.850 M 12x1,25x11</p> <p>b) 473.500 90430-12031 FI A 12x24x2</p>	<p>K:← 022.170 AS RD VMQ 34x48x7</p> <p>N:← 763.918 90043-11229-000 AW/BS RD FPM 38x50x8</p>	

DAIHATSU 				
HD-C 4 Cyl. 1590 ccm Cyl. 76,0 Ø Feroza 10/1988 → 12/1999 Hijet 10/1994 → 12/1995 Rocky 09/1993 → 12/1997 Social 05/1989 → 06/1992 Terios 05/1999 → 10/2005	ES⊕ 069.320 04112-87112-000	069.331 11115-87106-000 1,35 mm $\frac{1}{2}$ 77 Ø 		069.390 11213-87103-000 
HD-E 4 Cyl. 1590 ccm Cyl. 76,0 Ø Applause 06/1989 → 05/2000 Charade 03/1993 → 11/1999 Feroza 10/1988 → 12/1999 Rocky 09/1989 → 12/1997 Social 05/1989 → 08/1997	ES⊕ 069.320 04112-87112-000 →09/1997	069.331 11115-87106-000 1,35 mm $\frac{1}{2}$ 77 Ø 		069.390 11213-87103-000 
HD-EP 4 Cyl. 1590 ccm Cyl. 76,0 Ø Gran Move 05/1998 →		069.331 11115-87106-000 1,35 mm $\frac{1}{2}$ 77 Ø 		069.390 11213-87103-000 →05/2000 

			<p>a) </p> <p>b) </p>	<p>K: </p> <p>N: </p>	
<p>069.440 90048-12011-000 FPM 16x</p>	<p>069.470 17173-87104-000</p> 	<p>069.460 17177-87101-000</p> 	<p>b) 952.850 M 12x1,25x11</p> <p>b) 473.500 90430-12031 FI A 12x24x2</p>	<p>K:← 022.170 AS RD VMQ 34x48x7</p> <p>N:← 763.918 90043-11229-000 AW/BS RD FPM 38x50x8</p>	
<p>069.440 90048-12011-000 FPM 16x</p>	<p>069.470 17173-87104-000</p> 	<p>069.460 17177-87101-000 →09/1997</p> 	<p>b) 952.850 M 12x1,25x11</p> <p>b) 473.500 90430-12031 FI A 12x24x2</p>	<p>K:← 022.170 AS RD VMQ 34x48x7</p> <p>N:← 763.918 90043-11229-000 AW/BS RD FPM 38x50x8</p>	
<p>069.440 90048-12011-000 FPM 16x</p>	<p>069.470 17173-87104-000</p> 		<p>b) 952.850 M 12x1,25x11</p> <p>b) 473.500 90430-12031 FI A 12x24x2</p>	<p>K:← 022.170 AS RD VMQ 34x48x7</p> <p>N:← 763.918 90043-11229-000 AW/BS RD FPM 38x50x8</p>	



FIAT	ccm	kW	→	→	→	→
124 Spider	4	1368	103	03/2016		552 53 268 868
124 Spider	4	1368	119	03/2016		EAM 872
124 Spider	4	1368	122	03/2016	12/2017	EAM 872
126	2	704	19	09/1987	06/1996	126 A2.000 836 126 A2.048
127	4	903	29	06/1971	05/1983	100 GL.048 838
127	4	903	33	09/1971	12/1984	100 GL.000 838
127	4	1301	33	04/1981	12/1986	127 A5.000 862
127	4	1301	38	01/1986	05/1996	127 A5.000 862
133	4	843	27	06/1975	04/1981	127 A1.024 836
147	4	903	33	04/1977	12/1981	100 GL.000 838
147	4	1301	36	10/1980	10/1995	127 A5.000 862
147	4	1301	33	07/1982	06/1984	127 A5.000 862
147	4	1372	46	10/1980	10/1996	159A2038 874
500	2	875	63	09/2009		312 A2.000 838
500	2	875	77	10/2013		199 B6.000 836
500	2	875	59	12/2013		312 A5.000 836
500	2	964	48	09/2012		312 A4.000 840
500	2	964	44	12/2013		312 A4.000 840 312 A6.000
500	3	999	51	01/2020		463 41 162 842
500	4	1242	51	07/2007		169 A4.000 844
500	4	1368	74	10/2007		169 A3.000 864
500	4	1368	75	09/2008		169 A3.000 864
500	4	1368	77	02/2009		169 A3.000 864
500	4	1368	79	08/2011		169 A3.000 864
500	4	1368	99	02/2013		312 A1.000 866
500	4	1368	101	09/2013		EAF 872 EAM
500	4	1368	123	11/2014	12/2015	312 A1.000 866 312 A3.000
500L	4	1368	118	09/2013		312 A1.000 866
500 L	2	875	77	09/2012		199 B6.000 836
500 L	2	875	63	03/2013		312 A2.000 838
500 L	2	875	59	04/2017		312 A2.000 838
500 L	4	1368	70	09/2012		843 A1.000 870
500 L	4	1368	119	09/2013		EAM 872
500 L	4	1368	88	10/2013		940 B7.000 870
500 L	4	1368	93	05/2014		940 B7.000 870

FIAT	ccm	kW	→	→	→	→
500 L Multijet	4	1248	62	09/2012		199 B4.000 858
500 L Multijet	4	1248	70	06/2014		330 A1.000 860
500 L Multijet	4	1598	77	09/2012	05/2018	199 B5.000 884
500 L Multijet	4	1598	88	09/2013		552 80 444 886 940 C1.000 955 A3.000
500 Multijet	4	1248	55	10/2007		169 A1.000 854
500 Multijet	4	1248	70	09/2009		199 B1.000 858 312 B1.000 860
500 Multijet	4	1248	57	06/2016		312 B5.000 860
500X	4	1368	100	09/2014		552 63 624 870
500X	4	1368	103	09/2014		552 63 624 870
500X	4	1368	120	02/2015		552 63 623 870
500X	4	1368	125	02/2015		552 63 623 870
500X	4	1368	119	01/2016		EAM 872
500X	4	1368	88	03/2017		552 77 701 870
500X	4	1598	81	11/2014		552 63 842 886
500X Multijet	4	1248	70	11/2014		552 66 963 860 552 83 775
500X Multijet	4	1598	84	09/2014		552 60 384 886 552 80 444
500X Multijet	4	1598	88	09/2014		552 60 384 886 552 80 444
500X Multijet	4	1956	100	09/2014		552 63 087 924 552 63 088 926 552 83 099
500X Multijet	4	1956	103	09/2014		552 63 087 924 552 63 088
500X Multijet	4	1956	110	09/2018		552 63 088 924
900	4	903	26	01/1978	01/1986	100 GF 000 838
Argenta TD	4	2445	66	07/1983	08/1985	8144.61.500.81 954
Argo	3	999	57	06/2017		552 68 023 842
Argo	4	1332	73	03/2017		552 68 176 862
Argo	4	1332	80	04/2017		552 68 176 862
Argo	4	1747	96	03/2017		370 A0.011 894
Argo	4	1747	102	06/2017		370 A0.011 894
Avventura	4	1368	66	10/2014	07/2016	323 B6.600 868
Avventura	4	1368	104	01/2016	12/2019	198 A1.000 866
Avventura JTD	4	1248	68	10/2014	12/2019	199 A2.000 856
Barchetta	4	1747	96	04/1995	05/2005	183 A1.000 892 188 A6.000
Brava	4	1242	60	12/1998	12/2002	182 B2.000 848



FIAT	ccm	kW	→	→		
Brava	4	1242	59	10/2000	10/2001	188 A5.000 852
Brava	4	1370	55	10/1995	10/2001	182 A5.000 874
Brava	4	1370	59	10/1995	08/1998	182 A3.000 874
Brava	4	1581	66	10/1995	10/2001	182 A6.000 880
Brava	4	1581	76	02/1996	10/2001	182 A4.000 880
Brava	4	1581	78	08/1999	03/2000	182 A4.000 880
Brava	4	1596	76	01/1999	12/2002	182 B6.000 882
Brava	4	1596	78	04/2000	06/2003	182 B6.000 882
Brava	4	1747	83	10/1995	08/2001	182 A2.000 892
Brava	4	1747	97	02/2000	06/2003	183 A1.000 892
Brava	4	1929	48	10/1995	10/2001	160 A7.000 922
Brava JTD	4	1910	77	12/1998	10/2001	182 B4.000 904
Brava JTD	4	1910	74	09/2000	10/2001	182 B9.000 904
Brava TD	4	1910	55	03/1996	10/2001	182 A8.000 902
Brava TD	4	1910	74	03/1996	10/2001	182 A7.000 902
Bravo	4	1242	60	12/1998	10/2000	182 B2.000 848
Bravo	4	1242	59	10/2000	10/2001	188 A5.000 852
Bravo	4	1368	66	04/2007	12/2014	192 B2.000 864
Bravo	4	1368	110	09/2007	12/2014	198 A1.000 866
Bravo	4	1368	88	10/2007	12/2014	198 A4.000 866
Bravo	4	1368	103	04/2010	12/2014	198 A7.000 866
Bravo	4	1368	112	06/2011	12/2016	198 A1.000 866
Bravo	4	1370	55	10/1995	10/2001	182 A5.000 874
Bravo	4	1370	59	10/1995	10/2001	182 A3.000 874
Bravo	4	1581	66	10/1995	10/2001	182 A6.000 880
Bravo	4	1581	76	03/1996	10/2001	182 A4.000 880
Bravo	4	1596	76	09/2000	10/2001	182 B6.000 882
Bravo	4	1747	83	10/1995	10/2001	182 A2.000 892
Bravo	4	1747	97	12/2010	12/2016	370 A0.011 894
Bravo	4	1747	96	01/2011		370 A0.011 894
Bravo	4	1929	48	10/1995	10/2001	160 A7.000 922
Bravo	5	1998	108	10/1995	07/1998	182 A1.000 938
Bravo	5	1998	113	07/1998	10/2001	182 B7.000 938
Bravo JTD	4	1598	77	03/2008	12/2014	198 A3.000 882
Bravo JTD	4	1910	77	12/1998	10/2001	182 B4.000 904
Bravo JTD	4	1910	74	09/2000	10/2001	182 B9.000 904

FIAT	ccm	kW	→	→		
Bravo Multijet	4	1598	77	09/2007	12/2014	198 A3.000 882 844 A3.000 884
Bravo Multijet	4	1598	66	03/2008	12/2014	198 A6.000 884
Bravo Multijet	4	1598	88	03/2008	12/2014	198 A2.000 884
Bravo Multijet	4	1910	85	11/2006	12/2009	192 A1.000 908 192 B4.000 912
Bravo Multijet	4	1910	66	04/2007	12/2008	192 B5.000 910
Bravo Multijet	4	1910	88	04/2007	12/2014	192 A8.000 910
Bravo Multijet	4	1910	110	04/2007	12/2014	937 A5.000 916
Bravo Multijet	4	1956	120	09/2008	12/2014	198 A8.000 924 844 A2.000
Bravo Multijet	4	1956	121	09/2008	12/2014	198 A5.000 924
Bravo TD	4	1910	55	03/1996	10/2001	182 A8.000 902
Bravo TD	4	1910	74	03/1996	10/2001	182 A7.000 902
Campagnola	4	2445	53	06/1974	10/1989	8144.61.200 954
Cinquecento	2	704	23	12/1991	01/1996	170 A.000 836
Cinquecento	2	704	22	07/1994	01/1998	170 A.046 836
Cinquecento	4	899	29	07/1991	07/1999	1170 A1.000 838 1170 A1.046
Cinquecento	4	903	30	07/1991	09/1994	170 A1.000 840 170 A1.046
Cinquecento	4	1108	40	10/1994	02/1998	176 B2.000 842
Coupé	4	1747	96	03/1996	08/2000	183 A1.000 892
Coupé	5	1998	108	08/1996	09/1998	182 A1.000 938
Coupé	5	1998	113	04/1998	08/2000	182 B3.000 938
Coupé Turbo	5	1998	162	08/1996	08/2000	175 A3.000 936
Croma	4	1796	103	12/2005		939 A4.000 894
Croma	4	2198	108	06/2005		194 A1.000 946
Croma	4	2499	55	12/1985	12/1989	8144.67 960
Croma Multijet	4	1910	85	06/2005		939 A7.000 918
Croma Multijet	4	1910	88	06/2005	12/2011	939 A1.000 918
Croma Multijet	4	1910	110	06/2005	12/2011	939 A2.000 916
Croma Multijet	4	1910	100	12/2005		939 A8.000 918
Croma Multijet	5	2387	147	06/2005		939 A3.000 954
Croma TD	4	2500	85	05/1989	08/1996	8144.97 956 8144.97 Y 960 8144.97.2400
Croma TD	4	2500	77	12/1991	08/1996	8144.97 S 960
Cronos	4	1332	73	12/2017		552 68 176 862
Cronos	4	1332	80	02/2018		552 68 176 862

FIAT



FIAT

FIAT	ccm	kW	→	→	→	→	→
Cronos	4	1747	96	12/2017		370 A0.011	894
Cronos	4	1747	102	02/2018		370 A0.011	894
Doblo	4	1242	48	03/2001		223 A5.000	852
Doblo	4	1242	59	11/2001		223 A3.011	852
Doblo	4	1368	57	10/2005		350 A1.000	868
Doblo	4	1368	70	02/2010		843 A1.000	870
Doblo	4	1368	88	02/2010		198 A4.000	866
Doblo	4	1581	78	03/2001	08/2003	182 B6.000	882
Doblo	4	1596	76	10/2001		182 B6.000	882
Doblo	4	1596	78	11/2001	08/2003	182 B6.000	882
Doblo	4	1596	68	09/2002		182 B6.000	882
Doblo	4	1747	97	08/2010		370 A0.011	894
Doblo	4	1910	46	03/2001		223 A6.000	914
Doblo JTD	4	1248	51	05/2004	12/2006	188 A8.000 188 A9.000	854
Doblo JTD	4	1248	55	05/2005		199 A2.000	856
Doblo JTD	4	1910	74	10/2001		182 B9.000 223 B2.000	904 914
Doblo JTD	4	1910	77	07/2003		223 A7.000 223 B1.000	914
Doblo Multijet	4	1248	55	10/2005		199 A2.000 263 A6.000	856 860
Doblo Multijet	4	1248	62	10/2005		223 A9.000	858
Doblo Multijet	4	1248	66	02/2010		199 A3.000 263 A2.000	856 860
Doblo Multijet	4	1248	59	03/2016		225 A2.000	860
Doblo Multijet	4	1248	70	03/2016		330 A1.000	860
Doblo Multijet	4	1598	77	01/2010		198 A3.000 263 A8.000	882 884
Doblo Multijet	4	1598	66	02/2010		263 A4.000 263 A5.000	884
Doblo Multijet	4	1598	74	02/2010		263 A3.000 263 A9.000	884
Doblo Multijet	4	1598	70	03/2015		263 A7.000	884
Doblo Multijet	4	1598	88	03/2015		940 C1.000	886
Doblo Multijet	4	1910	88	10/2005		186 A9.000	906
Doblo Multijet	4	1956	99	01/2010		263 A1.000	924
Ducato	4	1905	50	04/1998	04/2002	D9B (XUD9A) DJY	900 902
Ducato	4	1905	59	05/1998	11/2001	DHX	898
Ducato	4	1929	52	02/1987	03/1994	149 B1.000	922

FIAT	ccm	kW	→	→	→	→	→
Ducato	4	1929	51	06/1990	04/2002	149 B1.000 230 A2.000	922
Ducato	4	1998	80	03/1994	04/2002	RFW	938
Ducato	4	1998	81	04/2002		RFL	938
Ducato	4	1998	71	11/2002	07/2006	RFL	938
Ducato	4	2445	53	09/1986	10/1987	8140.61	954
Ducato	4	2445	55	09/1986	05/1990	8140.61	954
Ducato	4	2499	68	09/1986	05/1990	8140.27	956
Ducato	4	2499	55	06/1990	04/2002	8140.67 8144.67	958 960
Ducato	4	2499	80	11/1994	04/1998	8140.47	958
Ducato	4	2500	55	01/1982	03/1994	8144.67	960
Ducato	4	2500	62	03/1994	04/2002	8140.67	958
Ducato	4	2800	64	02/1998	04/2002	8140.63	966
Ducato	4	2999	100	04/2009		F1CE0441A F1CFA401A F1CFA401C	966 968
Ducato JTD	4	1997	62	07/2001		RHV	934
Ducato JTD	4	2286	81	04/2002		F1AE0481C	948
Ducato JTD	4	2287	93	09/2009		F1AE0481T	950
Ducato JTD	4	2798	94	11/2000		8140.43S	962
Ducato JTD	4	2798	93	06/2005	08/2009	8140.43S	962
Ducato JTD	4	2799	94	10/2001	04/2002	8140.43S	962
Ducato JTD	4	2799	90	11/2003	07/2006	8140.43	964
Ducato JTD	4	2800	107	04/2004		8140.43N	964
Ducato Multijet	4	1956	85	06/2011		250 A1.000 250 A2.000	924
Ducato Multijet	4	2198	74	07/2006		4HV	946
Ducato Multijet	4	2287	88	07/2006		F1AE0481D F1AGL4114	948 952
Ducato Multijet	4	2287	96	07/2006		F1AE0481N F1AE3481D F1AGL411D	948 950 952
Ducato Multijet	4	2287	82	08/2006		F1AE3481G	950
Ducato Multijet	4	2287	109	06/2011		F1AE3481E	950
Ducato Multijet	4	2287	83	10/2011		F1AE3481G	950
Ducato Multijet	4	2287	110	04/2015		F1AGL411A F1AGL411C	952
Ducato Multijet	4	2287	130	12/2015		F1AGL4111 F1AGL411B	952
Ducato Multijet	4	2287	103	05/2019		F1AGL4113	952
Ducato Multijet	4	2287	118	05/2019		F1AGL4112	952



FIAT	ccm	kW	→	→	→	→
Ducato Multijet	4	2999	115	07/2006		F1CE0481D 968 F1CE3481M
Ducato Multijet	4	2999	116	07/2006		F1CE0481D 968 F1CE3481M
Ducato Multijet	4	2999	107	04/2010		F1CE3481N 968
Ducato Multijet	4	2999	130	06/2011		F1CE3481E 968
Ducato TD	4	1905	66	04/1998	04/2002	DHX 898 DHX (XUD9TF/L)
Ducato TD	4	1905	59	05/1998	11/2001	DHX 898
Ducato TD	4	1929	60	03/1989	04/2002	230 A3.000 922 280 A1.000
Ducato TD	4	1929	59	08/1994	04/2002	230 A4.000 922
Ducato TD	4	2499	68	09/1986	05/1990	8140.27 956
Ducato TD	4	2499	70	09/1986	05/1994	8140.27 956
Ducato TD	4	2499	80	06/1994	08/1998	8140.47 958
Ducato TD	4	2499	85	06/1994	09/2001	8140.47 958
Ducato TD	4	2500	70	06/1990	05/1994	8140.27 956
Ducato TD	4	2799	64	05/1998	11/2001	8140.63 966
Ducato TD	4	2799	90	05/1998	07/2006	8140.43 964
Ducato TD	4	2800	76	04/2005		8140.23.2200 962
Ducato TDI	4	2500	80	03/1994	04/2002	8140.47R 958
Ducato TDI	4	2500	85	03/1994	04/2002	8140.47 958
Ducato TDI	4	2800	90	10/1997	04/2002	8140.43 964
Duna	4	903	33	07/1991	10/1995	146 A.048 838
Duna	4	1116	43	01/1987	12/1991	146 A6.000 844
Duna	4	1301	49	01/1987	12/1991	146 A5.000 862
Duna	4	1301	33	05/1988	04/1992	146 B1.000 862
Duna	4	1372	51	07/1991	07/1996	160 A1.046 874
Duna	4	1580	60	11/1994	12/1995	159 A3.046 878
Duna	4	1581	63	02/1996	09/2000	159 A3.000 878
Duna	4	1698	44	01/1987	10/2001	146 B2.000 890 149 B3.000
Elba	4	1301	49	04/1991	02/1995	146 A5.000 862
Elba	4	1372	49	10/1993	02/1995	146 D5.000 874
Elba	4	1581	59	03/1988	02/1997	146 B7.011 878
Elba	4	1581	62	04/1989	12/1993	159 A3.000 878
Elba	4	1581	65	11/1989	10/1994	146 B6.011 878
Elba	4	1581	64	01/1991	12/1997	146 B6.011 878
Elba	4	1581	60	06/1992	10/1996	146 B7.011 878

FIAT	ccm	kW	→	→	→	→
Elba	4	1581	69	01/1994	12/1996	146 C6.000 878 146 D6.000
Elba	4	1698	43	04/1989	12/1996	146 B2.000 890
Elba	4	1698	42	04/1991	10/1997	146 B2.000 890
Fiorino	4	903	33	10/1977	10/1986	100 GL.000 838
Fiorino	4	994	41	01/1994	07/1995	146 B4.011 840
Fiorino	4	994	43	01/1996	12/1996	146 A7.011 840
Fiorino	4	999	33	11/1992	04/1996	156 A2.246 840
Fiorino	4	1116	40	11/1986	12/1993	146 A9.000 844
Fiorino	4	1242	50	01/2004		178 B5.000 846
Fiorino	4	1242	52	01/2007	12/2013	178 E9.011 848
Fiorino	4	1288	33	03/1982	01/1988	127 A5.000 862
Fiorino	4	1301	33	01/1982	01/1988	127 A5.000 862
Fiorino	4	1301	49	12/1987	12/1994	146 A5.000 862
Fiorino	4	1302	33	05/1984	12/1988	127 A5.000 862
Fiorino	4	1360	54	11/2007		KFT 864 KFV
Fiorino	4	1368	51	06/2008		350 A1.000 868
Fiorino	4	1368	57	06/2008		350 A1.000 868
Fiorino	4	1372	46	01/1989	03/2000	146 C5.000 874 146 D5.000
Fiorino	4	1372	52	11/1992	10/1996	146 C5.000 874
Fiorino	4	1372	49	05/1994	05/2001	146 C5.000 874 146 D5.000
Fiorino	4	1580	63	05/1991	10/1994	160 A2.011 878
Fiorino	4	1581	66	01/1990	12/1993	160 A2.011 878
Fiorino	4	1581	55	10/1993	05/2001	146 C6.000 878 146 D6.000
Fiorino	4	1581	69	10/1995	10/1996	146 B7.011 878 160 E1.011
Fiorino	4	1697	44	01/1988	10/1999	146 B2.000 890
Fiorino	4	1697	42	05/1988	10/1999	146 B2.000 890
Fiorino	4	1698	44	01/1988	05/2000	146 B2.000 890 149 B3.000
Fiorino Multijet	4	1248	55	11/2007		199 A2.000 856 199 A9.000 860
Fiorino Multijet	4	1248	70	07/2009		199 B1.000 858 330 A1.000 860
Fiorino Multijet	4	1248	59	03/2015		225 A2.000 860 552 83 775
Fiorino Multijet	4	1301	33	03/1989	08/1997	127 A5.000 862
Fiorino TD	4	1697	46	11/1996	05/2000	146 D7.000 890

FIAT



FIAT	ccm	kW					
Fiorino TD	4	1698	46	01/1997	05/2001	146 D7.000	890
Fiorino TD	4	1698	52	01/2004	08/2006	176 A3.000	890
Freemont	4	2360	125	08/2011		ED3 EDG	952
Freemont	4	2360	127	08/2011	12/2016	ED3 EDG	952
Freemont	4	2360	129	08/2012		ED3 EDG	952
Freemont	6	3604	206	08/2011		ERB	968
Freemont JTD	4	1956	100	08/2011		939 B5.000	926
Freemont JTD	4	1956	103	08/2011		939 B5.000 940 A5.000	926
Freemont JTD	4	1956	120	08/2011		939 B5.000	926
Freemont JTD	4	1956	125	08/2011		939 B5.000 940 A5.000	926
Fullback	4	2442	110	04/2016		4N15	954
Fullback	4	2442	113	04/2016		4N15	954
Fullback	4	2442	133	04/2016		4N15	954
Fullback	4	2477	81	04/2016		4D56	956
Fullback	4	2477	94	04/2016		4D56	956
Fullback	4	2477	100	04/2016		4D56	956
Fullback	4	2477	131	04/2016		4D56	956
Grande Punto	4	1242	48	10/2005		199 A4.000	852
Grande Punto	4	1242	51	06/2008		169 A4.000 199 A4.000	844 852
Grande Punto	4	1368	57	06/2005		350 A1.000	868
Grande Punto	4	1368	55	10/2005	07/2007	199 A7.000	866
Grande Punto	4	1368	70	10/2005	08/2011	199 A6.000	866
Grande Punto	4	1368	88	09/2007		198 A4.000	866
Grande Punto	4	1368	112	09/2007	07/2012	198 A1.000	866
Grande Punto	4	1368	66	06/2009	07/2014	323 B6.600	868
Grande Punto	4	1598	85	02/2011		310 A5.011	884
Grande Punto	4	1747	96	07/2010	07/2012	370 A0.011	894
Grande Punto Multijet	4	1248	55	10/2005		199 A2.000	856
Grande Punto Multijet	4	1248	66	10/2005	12/2010	199 A3.000	856
Grande Punto Multijet	4	1248	51	07/2008		199 B2.000	854
Grande Punto Multijet	4	1248	56	06/2009	07/2014	199 A2.000	856
Grande Punto Multijet	4	1248	62	04/2010		199 B4.000 223 A9.000	858 858
Grande Punto Multijet	4	1248	68	01/2012	01/2013	199 A2.000	856

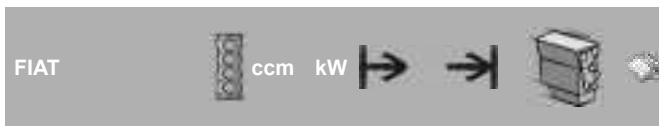

Grande Punto Multijet	4	1598	88	07/2008		955 A3.000	886
Grande Punto Multijet	4	1910	88	10/2005		939 A1.000	918
Grande Punto Multijet	4	1910	96	10/2005		199 A5.000	912
Grande Punto Multijet	4	1910	85	06/2006	12/2009	939 A7.000	918
Grand Siena	4	1598	86	03/2012		310 A5.011	884
Grand Siena	4	1598	85	10/2012		310 A5.011	884
Idea	4	1242	59	01/2004		188 A5.000	852
Idea	4	1368	66	12/2003		192 B2.000	864
Idea	4	1368	70	01/2004		843 A1.000	870
Idea	4	1368	60	09/2005		178 F3.011	864
Idea	4	1368	63	09/2005		178 F3.011	864
Idea	4	1368	57	10/2005		350 A1.000	868
Idea	4	1368	59	08/2010		178 F3.011	864
Idea	4	1598	77	08/2010		310 A5.011	884
Idea	4	1598	85	08/2010		310 A5.011	884
Idea	4	1598	86	08/2010	12/2015	310 A5.011	884
Idea	4	1747	97	08/2010	12/2016	370 A0.011	894
Idea Multijet	4	1248	51	01/2004		188 A9.000	854
Idea Multijet	4	1248	66	04/2005		199 A3.000	856
Idea Multijet	4	1248	70	05/2008	12/2012	199 B1.000	858
Idea Multijet	4	1598	88	05/2008		350 A2.000	884
Idea Multijet	4	1910	74	01/2004		188 B2.000	908
Linea	4	1368	88	05/2007		198 A4.000	866
Linea	4	1368	57	06/2007		350 A1.000	868
Linea	4	1368	84	09/2007	03/2013	323 B6.600	868
Linea	4	1368	112	10/2008	12/2012	198 A1.000	866
Linea	4	1368	66	12/2008		323 B6.600	868
Linea	4	1368	92	03/2016	12/2019	323 B6.600	868
Linea	4	1597	81	10/2011		310 A5.011	884
Linea	4	1747	96	01/2009		370 A0.011	894
Linea	4	1747	97	09/2010	12/2016	370 A0.011	894
Linea Multijet	4	1248	63	10/2006		199 A3.000	856
Linea Multijet	4	1248	66	06/2007		199 A3.000	856
Linea Multijet	4	1248	68	11/2008	12/2019	199 A3.000	856
Linea Multijet	4	1248	70	09/2009		199 A3.000 199 B1.000	856 858
Linea Multijet	4	1598	77	06/2009		198 A3.000	882



FIAT	ccm	kW	→	→			
Marea	4	1242	60	10/1998	05/2002	182 B2.000	848
Marea	4	1370	59	09/1996	05/2002	182 A3.000	874
Marea	4	1581	76	09/1996	05/2002	182 A4.000 185 A3.000 186 A4.000	880
Marea	4	1581	75	04/1997	02/1999	185 A3.000	880
Marea	4	1581	68	03/1999	08/2000	185 A3.000	880
Marea	4	1581	72	09/2000	08/2002	182 B5.098	880
Marea	4	1596	76	09/2000	08/2002	182 B6.000	882
Marea	4	1596	78	06/2005	12/2007	182 B6.000	882
Marea	4	1747	83	09/1996	05/2002	182 A2.000	892
Marea	4	1747	97	09/1996	12/2007	183 A1.000	892
Marea	5	1998	108	09/1996	04/1999	182 A1.000	938
Marea	5	1998	104	05/1998	09/2000	185 A5.011	938
Marea	5	1998	113	04/1999	02/2003	182 B7.000	938
Marea	5	1998	110	01/2001	05/2002	185 A8.000	938
Marea	5	2446	118	07/2000	12/2007	185 A7.011	956
Marea JTD	4	1910	77	12/1998	12/2002	182 B4.000	904
Marea JTD	4	1910	81	09/2000	08/2002	186 A6.000	904
Marea JTD	4	1910	79	01/2001	12/2007	182 B4.000 182 B9.000	904
Marea JTD	5	2387	96	04/1999	05/2002	185 A6.000 839 A5.000	952
Marea TD	4	1910	74	05/1996	06/2003	182 A7.000 182 B9.000	902 904
Marea TD	4	1910	55	09/1996	05/2002	182 A8.000	902
Marea TD	5	2387	91	09/1996	04/1999	185 A2.000	952
Mille	4	999	49	01/2010	12/2013	146 E1.011	840
Mobi	3	999	57	01/2017		552 68 023	842
Multipla	4	1581	70	04/1999	06/2010	186 A3.000	880
Multipla	4	1581	76	04/1999	06/2010	182 A4.000 186 A4.000	880
Multipla	4	1581	85	04/1999	04/2002	182 A4.000	880
Multipla	4	1596	76	09/2000	06/2010	182 B6.000	882
Multipla	4	1596	74	03/2001	08/2005	182 B6.000	882
Multipla	4	1596	70	04/2002	06/2010	182 B6.000	882
Multipla	4	1596	68	05/2004	08/2005	182 B6.000	882
Multipla	4	1596	77	11/2008	06/2010	182 B6.000	882
Multipla JTD	4	1910	77	04/1999	06/2010	182 B4.000	904
Multipla JTD	4	1910	81	09/2000	07/2002	186 A6.000	904

FIAT	ccm	kW	→	→			
Multipla JTD	4	1910	88	04/2002	06/2010	186 A9.000	906
Multipla JTD	4	1910	85	07/2002	06/2010	186 A8.000	906
Palio	4	999	52	08/2000	02/2003	178 D8.011	842
Palio	4	999	51	09/2000	02/2003	178 D8.011	842
Palio	4	999	55	12/2011	12/2017	146 E1.011	840
Palio	4	1108	40	07/1997	10/2003	178 B9.033	842
Palio	4	1108	42	06/2006	11/2011	187 A1.000	844
Palio	4	1242	54	04/1996		176 A8.000 178 B5.000 178 E2.000	846
Palio	4	1242	44	07/1997	10/2004	178 B7.045 178 C4.066 188 A4.000	846 850
Palio	4	1242	50	06/1999	10/2002	178 E2.000	846
Palio	4	1242	59	03/2000	01/2012	178 D6.011 188 A5.000	852
Palio	4	1242	60	06/2001	10/2007	188 A5.000	852
Palio	4	1242	53	07/2001	06/2005	178 B5.000	846
Palio	4	1242	49	09/2002	02/2004	178 E8.011	848
Palio	4	1242	52	11/2003		178 E9.011	848
Palio	4	1368	63	10/2002	10/2004	350 A1.000	868
Palio	4	1368	59	04/2005	12/2008	178 F3.011	864
Palio	4	1368	60	04/2005	07/2012	178 F3.011	864
Palio	4	1368	57	10/2005		178 F3.011 350 A1.000	864 868
Palio	4	1368	61	07/2006	04/2012	178 F3.011	864
Palio	4	1372	51	04/1996	10/2002	178 B2.000 178 B2.016	874
Palio	4	1581	74	04/1996	10/2002	178 B3.000	880
Palio	4	1581	78	06/1996	02/2003	178 A8.011 178 B3.000 178 D2.011	880
Palio	4	1581	60	02/1997	08/2001	178 C1.011 178 C8.011	880
Palio	4	1581	85	02/1997	10/2001	178 B3.000	880
Palio	4	1581	68	07/1997	10/2003	178 C1.011 178 C7.098 178 C8.011 178 D2.011	880
Palio	4	1581	70	07/1997		178 C7.098 178 D2.011	880
Palio	4	1581	73	01/2002	12/2007	178 D2.011	880
Palio	4	1596	76	06/1996	01/2012	182 B6.000	882
Palio	4	1596	74	06/2006		182 B6.000	882

FIAT



FIAT

FIAT	ccm	kW	→	→	→	→
Palio	4	1596	75	06/2006		178 E7.000 882 182 B6.000
Palio	4	1598	86	08/2010		310 A5.011 884
Palio	4	1598	85	11/2011		310 A5.011 884
Palio	4	1598	84	10/2012		310 A5.011 884
Palio	4	1698	42	04/1996	09/2002	176 B3.000 890
Palio	4	1747	97	06/2012	12/2016	370 A0.011 894
Palio	4	1910	46	03/2001		223 A6.000 914
Palio	4	1910	48	03/2001		223 A6.000 914
Palio JTD	4	1248	51	06/2003	01/2012	188 A9.000 854
Palio JTD	4	1910	59	09/2001		188 A2.000 908
Palio Multijet	4	1248	55	03/2008	11/2011	188 A9.000 854
Palio Multijet	4	1248	66	04/2011	07/2011	188 A9.000 854
Palio TD	4	1698	51	04/1996	01/2012	176 A3.000 890
Palio TD	4	1698	52	02/1997	10/2003	176 A3.000 890 176 A5.000 178 C9.066
Palio TD	4	1698	53	07/1997		176 A3.000 890 176 A5.000
Palio TD	4	1698	59	06/2001	03/2010	176 A5.000 890
Panda	4	770	25	01/1986	10/2003	156 A4.000 836
Panda	2	875	57	02/2012		312 A2.000 836 312 A7.000 838
Panda	2	875	63	02/2012		312 A2.000 838 463 37 566
Panda	2	875	59	11/2013		312 A2.000 836 312 A5.000 838
Panda	2	875	66	06/2014		312 A2.000 836 312 A7.000 838
Panda	2	875	51	03/2019		463 37 566 838
Panda	4	899	29	04/1992	12/1996	1170 A1.046 838
Panda	4	903	33	10/1980	06/1994	100 GL3.000 838 146 A.000 146 A.048
Panda	2	964	48	02/2012		312 A4.000 840
Panda	2	964	44	12/2013		312 A4.000 840 312 A6.000
Panda	4	999	37	01/1985	12/1992	156 A3.000 840
Panda	4	999	32	01/1986	04/1992	156 A2.100 840 156 A3.100
Panda	4	999	33	05/1986	02/2004	141 C2.000 840 156 A2.246
Panda	3	999	51	01/2020		463 41 162 842

FIAT	ccm	kW	→	→	→	→
Panda	4	1108	37	05/1991	07/2004	156 C.046 842
Panda	4	1108	40	02/1995		176 B2.000 842 187 A1.000 844
Panda	4	1242	44	09/2003		188 A4.000 850
Panda	4	1242	51	03/2010		169 A4.000 844
Panda	4	1302	27	04/1986	12/1992	156 A5.000 862
Panda	4	1368	74	10/2006		169 A3.000 864
Panda	4	1368	57	10/2009		350 A1.000 868
Panda Multijet	4	1248	51	09/2003		188 A8.000 854
Panda Multijet	4	1248	55	01/2006		169 A1.000 854 169 A5.000 860 199 A1.000 199 A9.000
Panda Multijet	4	1248	59	06/2014		199 A9.000 860 225 A2.000 312 A8.000 312 B2.000
Panda Multijet	4	1248	70	04/2015		199 B1.000 858 312 B1.000 860 330 A1.000
Penny	4	1116	43	01/1986	12/1990	146 A6.000 844
Penny	4	1301	49	01/1986	12/1990	146 A5.000 862
Penny	4	1301	33	04/1986	12/1988	146 B1.000 862
Penny	4	1698	44	01/1986	12/1990	149 B3.000 890
Premio	4	1580	63	11/1989	06/1994	146 B6.011 878
Premio	4	1581	62	03/1985	12/1996	159 A3.000 878
Premio	4	1581	59	11/1989	06/1994	146 B7.011 878
Premio	4	1581	60	08/1993	12/1996	146 B7.011 878 160 A2.011
Pulse	4	1332	80	10/2021		552 68 176 862
Punto	2	875	63	03/2012		312 A2.000 838
Punto	2	875	77	07/2013		199 B6.000 836
Punto	2	875	74	12/2013		199 B6.000 836 199 B7.000
Punto	4	1108	40	09/1993	02/2000	176 A6.000 842 176 B2.000
Punto	4	1242	44	09/1993	03/2012	176 B1.000 846 176 B4.000 850 188 A4.000
Punto	4	1242	54	10/1993	09/1999	176 A8.000 846
Punto	4	1242	43	01/1994	06/2000	176 A7.000 846
Punto	4	1242	63	04/1997	06/2000	176 B9.000 848
Punto	4	1242	59	09/1999	04/2006	188 A5.000 852
Punto	4	1242	38	04/2004	04/2006	188 A4.000 850



FIAT	ccm	kW	→	→	→	→
Punto	4	1242	51	03/2012		169 A4.000 844
Punto	4	1242	49	02/2014		199 B9.000 844
Punto	4	1368	70	09/2003	03/2012	843 A1.000 870
Punto	4	1368	71	11/2005	03/2012	199 A6.000 866 843 A1.000 870
Punto	4	1368	112	02/2009		198 A1.000 866
Punto	4	1368	57	03/2009		350 A1.000 868
Punto	4	1368	55	03/2012		199 A7.000 866
Punto	4	1368	77	03/2012		955 A6.000 872
Punto	4	1368	101	09/2012		955 A2.000 872
Punto	4	1372	98	10/1993	03/1997	176 A4.000 874
Punto	4	1372	96	09/1996	07/1999	176 B6.000 874
Punto	4	1581	65	01/1994	04/1997	176 A9.000 878
Punto	4	1598	85	07/2010	07/2012	310 A5.011 884
Punto	4	1598	86	10/2014		310 A5.011 884
Punto	4	1698	42	04/1994	02/2000	176 B3.000 890
Punto	4	1747	96	09/1999	03/2012	183 A1.000 892 188 A6.000 860
Punto	4	1747	97	07/2010		370 A0.011 894
Punto	4	1910	44	09/1999	03/2012	188 A3.000 914
Punto Evo	4	1242	48	10/2009	02/2012	199 A4.000 852
Punto Evo	4	1242	51	10/2009	02/2012	169 A4.000 844
Punto Evo	4	1368	57	03/2009	02/2012	350 A1.000 868
Punto Evo	4	1368	55	07/2009	02/2012	199 A7.000 866
Punto Evo	4	1368	77	10/2009	02/2012	955 A6.000 872
Punto Evo	4	1368	99	10/2009	02/2012	955 A2.000 872
Punto Evo	4	1368	66	10/2014		323 B6.600 868
Punto Evo Multijet	4	1248	51	07/2008	02/2012	199 B2.000 854
Punto Evo Multijet	4	1248	55	03/2009	02/2012	199 A2.000 856 199 A9.000 860
Punto Evo Multijet	4	1248	66	03/2009	02/2012	199 A3.000 856
Punto Evo Multijet	4	1248	70	03/2009	02/2012	199 B1.000 858
Punto Evo Multijet	4	1248	62	10/2009	02/2012	199 B4.000 858 223 A9.000 860
Punto Evo Multijet	4	1248	56	09/2010		199 A2.000 856 199 A9.000 860
Punto Evo Multijet	4	1248	68	10/2014		199 A2.000 856 199 A3.000 860
Punto Evo Multijet	4	1598	88	10/2009	02/2012	955 A3.000 886
Punto JTD	4	1248	51	06/2003	03/2012	188 A9.000 854

FIAT	ccm	kW	→	→	→	→
Punto JTD	4	1910	59	09/1999	03/2012	188 A2.000 908
Punto JTD	4	1910	63	02/2000	03/2012	188 A7.000 908
Punto JTD	4	1910	74	06/2003	03/2012	188 B2.000 908
Punto Multijet	4	1248	55	04/2008		199 A2.000 856 199 A9.000 860
Punto Multijet	4	1248	70	03/2009		199 B1.000 858 330 A1.000 860
Punto Multijet	4	1248	62	03/2012		199 B4.000 858
Punto Multijet	4	1248	59	12/2013		199 B8.000 858
Punto Multijet	4	1248	66	05/2018		955 B2.000 860
Punto Multijet	4	1368	99	03/2012		955 A2.000 872
Punto TD	4	1698	51	01/1994	09/1999	176 A3.000 890
Punto TD	4	1698	52	01/1994	02/2000	176 A5.000 890
Punto TD	4	1698	46	09/1996	09/1999	176 B7.000 890
Qubo	4	1360	54	02/2008		KFT 864 KFV 860
Qubo	4	1368	57	10/2009		350 A1.000 868
Qubo Multijet	4	1248	55	02/2008		199 A2.000 856 199 A9.000 860
Qubo Multijet	4	1248	70	07/2010		199 B1.000 858 330 A1.000 860 552 83 775
Qubo Multijet	4	1248	59	03/2015		225 A2.000 860
Regata	4	1581	63	09/1983	04/1995	159 A3.000 878
Regata	4	1581	65	01/1987	08/1995	159 A3.000 878
Regata	4	1698	44	01/1984	12/1989	149 B3.000 890
Regata	4	1929	48	04/1984	07/1989	149 A1.000 922
Ritmo	4	1698	44	05/1985	12/1987	138 C.000 890 149 B3.000 860
Scudo	4	1581	58	02/1996	12/2006	220 A 2.000 880
Scudo	4	1868	51	04/1998	12/2006	WJY (DW8) 896 WJY (DW8B) WJZ (DW8)
Scudo	4	1905	51	02/1996	12/2006	D9B 900
Scudo	4	1997	100	05/2000	12/2006	RFN (EW10J4) 928
Scudo JTD	4	1997	80	05/1999	12/2006	RHK 930 (DW10UTED4) 936 RHM (DW10ATED4) RHW (DW10ATED4) RHZ
Scudo JTD	4	1997	69	10/1999	12/2006	RHX 936

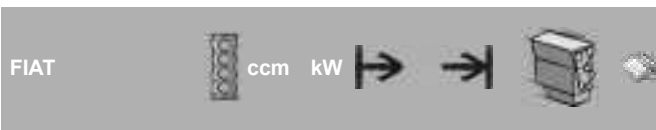

Model	Cylinders	Capacity (ccm)	Power (kW)	Year 1	Year 2	Engine Code	Power (kW)
Scudo Multijet	4	1560	66	01/2007		9H07 (DV6UC) 9HM (DV6UC) 9HU	876
Scudo Multijet	4	1997	88	01/2007		RHG RHK	928 932
Scudo Multijet	4	1997	100	01/2007		DW10BTED4 RHR	932
Scudo Multijet	4	1997	120	07/2010		RH02 RHH	928
Scudo Multijet	4	1997	94	04/2011		RH02	928
Scudo TD	4	1905	66	02/1996	12/2006	DHX (XUD9TF/L)	898
Scudo TD	4	1905	68	02/1996	12/2006	D8B DHX (XUD9TF/L)	898
Sedici	4	1586	79	06/2006	10/2014	M16A	880
Sedici	4	1586	88	06/2006	10/2014	M16A	880
Sedici Multijet	4	1910	88	06/2006	10/2011	D19AA	920
Sedici Multijet	4	1956	99	06/2006	10/2014	D20AA	926
Seicento	4	899	29	11/1997	01/2010	1170 A1.046	838
Seicento	4	1108	40	01/1998	01/2010	176 B2.000 187 A1.000	842 844
Siena	4	999	52	03/2000	02/2003	178 D8.011	842
Siena	4	1242	54	09/1998	12/2002	178 B5.000	846
Siena	4	1242	60	06/2001	10/2007	188 A5.000	852
Siena	4	1242	44	09/2001	12/2012	178 C4.066 188 A4.000	846 850
Siena	4	1242	59	09/2001	12/2009	188 A5.000	852
Siena	4	1242	49	09/2002	02/2004	178 E8.011	848
Siena	4	1242	52	03/2004	12/2009	178 E9.011	848
Siena	4	1368	60	06/2004	12/2010	178 F3.011	864
Siena	4	1368	63	07/2005	10/2013	178 F3.011	864
Siena	4	1368	57	01/2007	12/2009	178 F3.011 350 A1.000	864 868
Siena	4	1368	65	11/2007	06/2012	178 F3.011	864
Siena	4	1372	51	04/1996	12/2009	178 B2.000 178 B2.016	874 876
Siena	4	1581	56	09/1997	10/1998	146 C6.000 146 D6.000	878 880
Siena	4	1581	60	09/1997	03/2000	146 D6.000	878
Siena	4	1581	74	09/1998	12/2009	178 B3.000	880
Siena	4	1581	76	09/1998	12/2004	178 B3.000	880
Siena	4	1581	68	03/1999	03/2000	146 D6.000	878

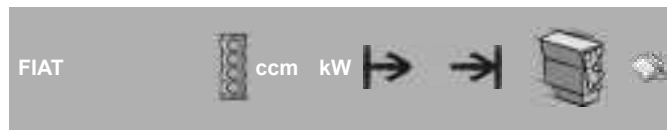

Model	Cylinders	Capacity (ccm)	Power (kW)	Year 1	Year 2	Engine Code	Power (kW)
Siena	4	1596	78	10/1997	02/2003	178 A8.011	880
Siena	4	1596	76	11/2000	12/2012	182 B6.000	882
Siena	4	1598	85	08/2010	10/2013	310 A5.011	884
Siena	4	1598	86	08/2010	06/2012	310 A5.011	884
Siena	4	1598	84	09/2010	10/2013	310 A5.011	884
Siena	4	1697	46	05/1999	12/2009	178 C9.066	890
Siena	4	1697	47	05/1999	12/2009	176 B7.000	890
Siena	4	1698	52	03/2002	12/2009	176 A3.000	890
Siena	4	1910	46	01/2004	12/2008	223 A6.000	914
Siena JTD	4	1248	51	09/2003	12/2009	188 A9.000	854
Siena TD	4	1697	51	02/2006	12/2009	176 A3.000	890
Stilo	4	1242	59	02/2002	11/2006	188 A5.000	852
Stilo	4	1368	70	10/2003	08/2008	843 A1.000	870
Stilo	4	1368	66	03/2005	08/2008	192 B2.000	864
Stilo	4	1596	76	10/2001	08/2008	182 B6.000	882
Stilo	4	1596	100	04/2005	08/2008	182 B6.000	882
Stilo	4	1598	77	03/2005	08/2008	192 B3.000	882
Stilo	4	1747	98	10/2001	08/2008	192 A4.000	892
Stilo	4	1747	90	06/2002	12/2004	192 A4.000	892
Stilo	5	2446	125	10/2001	04/2007	192 A2.000	956
Stilo	5	2446	123	01/2004	08/2008	192 A7.011	956
Stilo JTD	4	1910	59	10/2001	08/2008	192 A3.000	910
Stilo JTD	4	1910	85	10/2001	08/2008	192 A1.000 192 B4.000 937 A7.000	908 912 916
Stilo JTD	4	1910	93	09/2003	08/2008	937 A4.000	914
Stilo JTD	4	1910	103	09/2003	08/2008	192 A5.000	910
Stilo JTD	4	1910	100	02/2004	08/2008	192 B1.000	912
Stilo JTD	4	1910	66	09/2004	08/2008	192 B5.000	910
Stilo JTD	4	1910	88	09/2005	08/2008	192 A8.000	910
Stilo JTD	4	1910	110	09/2005	08/2008	937 A5.000	916
Stilo Multijet	4	1910	74	09/2005	08/2008	192 A9.000	910
Stilo Multijet	4	1910	88	09/2005	08/2008	192 A8.000	910
Stilo Multijet	4	1910	110	09/2005	08/2008	937 A5.000	916
Strada	4	1242	54	06/1999	12/2006	178 B5.000	846
Strada	4	1242	44	04/2003		188 A4.000	850
Strada	4	1242	49	06/2004		178 E8.011	848
Strada	4	1242	60	11/2005		178 B7.045	846



FIAT	ccm	kW	→	→	→	→
Strada	4	1332	80	06/2020		552 68 176 862
Strada	4	1332	79	12/2021		552 68 176 862
Strada	4	1368	60	06/2005		178 F3.011 864
Strada	4	1580	68	11/1998	12/2000	178 C1.011 880
Strada	4	1581	78	02/1998	02/2003	178 D2.011 880
Strada	4	1581	76	11/2005		178 D2.011 880
Strada	4	1598	85	09/2009		310 A5.011 884
Strada	4	1598	86	09/2009		310 A5.011 884
Strada	4	1747	97	08/2010	01/2021	370 A0.011 894
Strada	4	1910	46	12/2000		223 A6.000 914
Strada JTD	4	1910	59	04/2003		188 A2.000 908
Strada Multijet	4	1248	62	05/2006		223 A9.000 858
Strada Multijet	4	1248	64	03/2010		199 B1.000 858
Strada Multijet	4	1248	70	10/2010		199 B1.000 858
Strada TD	4	1698	51	06/1999	12/2006	176 A3.000 890
Strada TD	4	1698	52	02/2002	01/2010	176 A3.000 890
Talento	4	1598	70	06/2016		R9M 413 888
Talento	4	1598	85	06/2016		R9M 408 888
Talento	4	1598	89	06/2016		R9M 413 888
Talento	4	1598	92	06/2016		R9M 452 888
Talento	4	1598	107	06/2016		R9M 452 888
Talento	4	1929	52	03/1989	03/1994	149 B1.000 922
Tempra	4	1372	51	04/1990	08/1996	159 A2.000 874 160 A1.046 836 A4.000
Tempra	4	1372	57	03/1991	08/1996	159 A2.000 874
Tempra	4	1372	54	04/1991	06/1993	159 A2.000 874
Tempra	4	1581	63	03/1990	08/1996	159 A3.000 878 159 B9.000
Tempra	4	1581	51	04/1990	07/1996	159 A3.048 878
Tempra	4	1581	57	06/1990	08/1996	159 A3.046 878 835 C1.000
Tempra	4	1581	55	06/1992	08/1996	159 A3.048 878 835 C1.000
Tempra	4	1581	66	06/1994	08/1996	159 B9.000 878
Tempra	4	1929	66	04/1990	07/1996	160 A6.000 920
Tempra	4	1929	48	07/1991	08/1996	149 A1.000 922 160 A7.000
Tempra TD	4	1929	66	05/1990	08/1996	160 A6.000 920 160 D1.000

FIAT	ccm	kW	→	→	→	→
Tempra TD	4	1929	59	03/1992	08/1996	160 B6.046 920
Tipo	4	1108	41	01/1988	10/1991	160 A3.000 842
Tipo	4	1248	70	10/2015		199 B1.000 858 552 66 963 860 552 83 775
Tipo	4	1368	70	10/2015		843 A1.000 870
Tipo	4	1368	88	03/2016		940 B7.000 870
Tipo	4	1372	52	07/1987	12/1989	160 A1.000 874 160 A1.048
Tipo	4	1372	51	05/1989	04/1995	160 A1.046 874 160 A1.048 836 A4.000
Tipo	4	1372	57	05/1989	04/1995	159 A2.000 874
Tipo	4	1580	56	03/1993	10/1995	159 A3.046 878 159 A3.048 835 C1.000
Tipo	4	1581	61	01/1988	10/1991	160 A2.000 878
Tipo	4	1581	58	03/1988	10/1992	160 A2.000 878
Tipo	4	1581	66	05/1989	10/1995	159 A3.000 878
Tipo	4	1581	57	07/1990	01/1993	159 A3.046 878
Tipo	4	1581	55	10/1992	04/1995	159 A3.048 878 835 C1.000
Tipo	4	1581	60	03/1993	10/1995	160 E2.011 878
Tipo	4	1581	68	12/1995	05/1997	160 E1.011 878
Tipo	4	1581	69	12/1995	12/1996	159 A3.000 878
Tipo	4	1598	81	10/2015		552 68 036 886
Tipo	4	1598	88	10/2015		552 60 384 886 552 80 444 940 C1.000
Tipo	4	1598	84	09/2016		552 60 384 886 552 80 444
Tipo	4	1697	43	01/1988	10/1994	149 B4.000 890
Tipo	4	1697	45	01/1988	10/1995	149 B4.000 890
Tipo	4	1929	48	07/1991	08/1995	149 A1.000 922 160 A7.000
Tipo TD	4	1929	69	04/1990	10/1992	160 A6.046 920
Tipo TD	4	1929	66	09/1990	04/1995	160 A6.000 920 160 A6.046 160 D1.000
Tipo TD	4	1929	59	03/1992	06/1993	160 B6.046 920
Toro	4	1747	102	01/2016		370 A0.011 894
Toro	4	1747	96	10/2018		370 A0.011 894
Toro	4	1956	125	01/2016		552 63 088 924
Ulysse	4	1761	73	05/1997	08/2002	LFW (XU7JP) 894

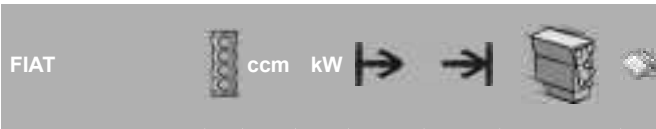

FIAT	ccm	kW					
Ulysse	4	1997	80	05/1999	08/2002	RHW (DW10ATED4)	930
Ulysse	4	1997	100	09/2000	06/2011	RFN (EW10J4)	928
Ulysse	4	1998	89	06/1994	08/2002	RFU (XU10J2C)	938
Ulysse	4	1998	97	05/1998	09/2000	RFV	940
Ulysse	6	2946	150	08/2002	06/2011	XFW	966
Ulysse JTD	4	1997	80	10/1999	08/2006	RHW (DW10ATED4) RHZ	930 936
Ulysse JTD	4	1997	79	05/2003	08/2006	RHM (DW10ATED4)	930
Ulysse JTD	4	2179	94	08/2002	08/2006	4HW (DW12ATED4)	944
Ulysse JTD	4	2179	120	03/2008	06/2011	4HP 4HR	944
Ulysse Multijet	4	1997	88	05/2006	06/2011	RHK	932
Ulysse Multijet	4	1997	100	05/2006	06/2011	RHR	932
Ulysse Multijet	4	2179	125	03/2008	06/2011	4HS 4HT (DW12BTED4)	944
Ulysse TD	4	1905	66	02/1995	08/2002	DHX (XUD9TF/L)	898
Ulysse TD	4	1905	68	05/1997	12/1999	DHX (XUD9TF/L)	898
Ulysse TD	4	2088	80	03/1996	10/1999	P8C	942
Ulysse Turbo	4	1998	108	06/1994	08/2002	RGX (XU10J2CTE)	940
Uno	4	903	33	03/1983	07/1996	146 A.000 146 A1.000	838
Uno	4	903	30	02/1984	08/1989	100 GL.000	838
Uno	4	903	34	02/1984	12/1988	146 A.000	838
Uno	4	994	35	08/1990	06/2001	146 A2.166	840
Uno	4	994	40	01/1991	12/1992	146 B4.000	840
Uno	4	994	41	05/1993	08/2000	146 C4.011 146 C8.000	840
Uno	4	994	42	05/1993	06/2001	146 A7.011 146 C8.000	840
Uno	4	999	33	10/1984	10/1995	156 A2.000 156 A2.246	840
Uno	4	999	32	06/1986	12/1993	156 A2.048 156 A2.100	840
Uno	4	999	31	06/1989	02/1992	156 A2.000	840
Uno	4	999	34	05/1998	08/2000	156 A2.246	840
Uno	4	999	40	06/2001	12/2003	156 A2.246	840
Uno	4	999	49	06/2005	12/2009	146 E1.011	840

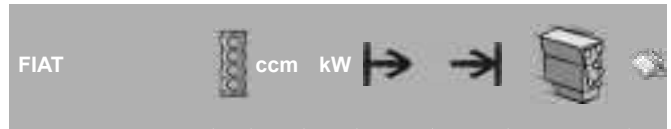

Uno	3	999	57	09/2016		552 68 023	842
Uno	4	1108	41	04/1986	06/2006	160 A3.000	842
Uno	4	1108	43	10/1988	06/2006	160 A3.000	842
Uno	4	1108	42	04/1989	12/1992	160 A3.000	842
Uno	4	1108	37	01/1990	12/1993	156 C.046	842
Uno	4	1108	36	08/1992	12/1996	160 A3.000	842
Uno	4	1116	36	06/1992	12/1993	146 C3.000	842
Uno	4	1242	44	08/2000	08/2009	188 A4.000	850
Uno	4	1242	48	01/2004	04/2010	178 E8.011	848
Uno	4	1242	60	11/2005		178 E9.011	848
Uno	4	1242	52	10/2006	08/2013	178 E9.011	848
Uno	4	1242	50	01/2007	08/2013	178 E8.011 178 E9.011	848
Uno	4	1302	33	06/1983	03/1992	127 A5.000 146 B1.000	862
Uno	4	1332	80	09/2016		552 68 176	862
Uno	4	1332	73	09/2018		552 68 176	862
Uno	4	1372	49	10/1988	03/2001	160 A1.046	874
Uno	4	1372	52	10/1988	06/2006	160 A1.046 160 A1.048	874
Uno	4	1372	74	01/1989	12/1991	146 A8.000	874
Uno	4	1372	51	09/1989	07/1996	160 A1.046	874
Uno	4	1372	53	09/1989	12/1993	146 C1.000	874
Uno	4	1581	62	01/1989	04/1993	160 A2.011	878
Uno	4	1581	65	11/1989	04/1993	159 A3.046 160 A2.011	878
Uno	4	1581	66	05/1993	12/1995	159 A3.048	878
Uno	4	1697	43	02/1988	08/2000	146 B2.000 149 B4.046	890
Uno	4	1698	44	07/1986	08/1989	149 B3.000	890
Uno	4	1698	42	09/1989	12/1993	146 B2.000	890
Uno	4	1929	58	01/1989	12/1991	160B6000	920
Uno	4	1929	44	09/1989	03/1994	149 B5.046	920
Uno Turbo	4	1301	77	04/1985	08/1989	146 A2.000	862
Uno Turbo	4	1301	73	01/1987	12/1987	146 A2.146	862
Uno Turbo	4	1301	74	09/1989	03/1991	146 A2.246	862
Uno Turbo	4	1372	77	10/1988	08/2000	146 A8.000	874
Uno Turbo	4	1372	82	09/1989	09/1993	146 A8.046	874
Uno Turbo	4	1372	87	12/1989	12/1996	146 A8.000	874

FIAT



FIAT

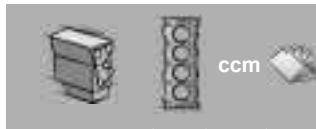

100 GF.000	4	903	838
100 GL.000	4	903	838
100 GL.048	4	903	838
100 GL3.000	4	903	838
1170 A1.000	4	899	838
1170 A1.046	4	899	838
126 A2.000	2	704	836
126 A2.048	2	704	836
127 A1.024	4	843	836
127 A5.000	4	1301	862
138 C.000	4	1698	890
141 C2.000	4	999	840
146 A.000	4	903	838
146 A.048	4	903	838
146 A1.000	4	903	838
146 A2.000	4	1301	862
146 A2.146	4	1301	862
146 A2.166	4	994	840
146 A2.246	4	1301	862
146 A5.000	4	1301	862
146 A6.000	4	1116	844
146 A7.011	4	994	840
146 A8.000	4	1372	874
146 A8.046	4	1372	874
146 A9.000	4	1116	844
146 B1.000	4	1301	862
146 B2.000	4	1698	890
146 B4.000	4	994	840
146 B4.011	4	994	840
146 B6.011	4	1581	878
146 B7.011	4	1581	878
146 C1.000	4	1372	874
146 C3.000	4	1108	842
146 C4.011	4	994	840
146 C5.000	4	1372	874
146 C6.000	4	1581	878
146 C8.000	4	994	840



146 D5.000	4	1372	874
146 D6.000	4	1581	878
146 D7.000	4	1698	890
146 E1.011	4	999	840
149 A1.000	4	1929	922
149 B1.000	4	1929	922
149 B2.000	4	1698	890
149 B3.000	4	1698	890
149 B4.000	4	1698	890
149 B4.046	4	1698	890
149 B5.046	4	1929	920
156 A2.000	4	999	840
156 A2.0157	4	999	840
156 A2.048	4	999	840
156 A2.050	4	999	840
156 A2.100	4	999	840
156 A2.146	4	999	840
156 A2.246	4	999	840
156 A3.000	4	999	840
156 A3.100	4	999	840
156 A4.000	4	770	836
156 A4.048	4	770	836
156 A5.000	4	1301	862
156 C.046	4	1108	842
159 A2.000	4	1372	874
159A2038	4	1372	874
159 A3.000	4	1581	878
159 A3.046	4	1581	878
159 A3.048	4	1581	878
159 B9.000	4	1581	878
160 A1.000	4	1372	874
160 A1.046	4	1372	874
160 A1.048	4	1372	874
160 A2.000	4	1581	878
160 A2.011	4	1581	878
160 A3.000	4	1108	842
160 A6.000	4	1929	920



160 A6.046	4	1929	920
160 A7.000	4	1929	922
160 B6.046	4	1929	920
160B6000	4	1929	920
160 D1.000	4	1929	920
160 E1.011	4	1581	878
160 E2.011	4	1581	878
169 A1.000	4	1248	854
169 A3.000	4	1368	864
169 A4.000	4	1242	844
169 A5.000	4	1248	854
170 A.000	2	704	836
170 A.046	2	704	836
170 A1.000	4	903	840
170 A1.046	4	903	840
175 A3.000	5	1998	936
176 A3.000	4	1698	890
176 A4.000	4	1372	874
176 A5.000	4	1698	890
176 A6.000	4	1108	842
176 A7.000	4	1242	846
176 A8.000	4	1242	846
176 A9.000	4	1581	878
176 B1.000	4	1242	846
176 B2.000	4	1108	842
176 B3.000	4	1698	890
176 B4.000	4	1242	846
176 B6.000	4	1372	874
176 B7.000	4	1698	890
176 B9.000	4	1242	848
178 A8.011	4	1581	880
178 B2.000	4	1372	874
178 B2.016	4	1372	874
178 B3.000	4	1581	880
178 B5.000	4	1242	846
178 B7.045	4	1242	846
178 B9.033	4	1108	842



178 C1.011	4	1581	880
178 C4.066	4	1242	846
178 C7.098	4	1581	880
178 C8.011	4	1581	880
178 C9.066	4	1698	890
178 D2.011	4	1581	880
178 D6.011	4	1242	852
178 D8.011	4	999	842
178 E2.000	4	1242	846
178 E7.000	4	1596	882
178 E8.011	4	1242	848
178 E9.011	4	1242	848
178 F3.011	4	1368	864
182 A1.000	5	1998	938
182 A2.000	4	1747	892
182 A3.000	4	1370	874
182 A4.000	4	1581	880
182 A5.000	4	1370	874
182 A6.000	4	1581	880
182 A7.000	4	1910	902
182 A8.000	4	1910	902
182 B2.000	4	1242	848
182 B3.000	5	1998	938
182 B4.000	4	1910	904
182 B5.098	4	1581	880
182 B6.000	4	1596	882
182 B7.000	5	1998	938
182 B9.000	4	1910	904
183 A1.000	4	1747	892
185 A2.000	5	2387	952
185 A3.000	4	1581	880
185 A5.011	5	1998	938
185 A6.000	5	2387	952
185 A7.011	5	2446	956
185 A8.000	5	1998	938
186 A3.000	4	1581	880
186 A4.000	4	1581	880



FIAT



FIAT



186 A6.000	4	1910	904
186 A8.000	4	1910	906
186 A9.000	4	1910	906
187 A1.000	4	1108	844
188 A2.000	4	1910	908
188 A3.000	4	1910	914
188 A4.000	4	1242	850
188 A5.000	4	1242	852
188 A6.000	4	1747	892
188 A7.000	4	1910	908
188 A8.000	4	1248	854
188 A9.000	4	1248	854
188 B2.000	4	1910	908
192 A1.000	4	1910	908
192 A2.000	5	2446	956
192 A3.000	4	1910	910
192 A4.000	4	1747	892
192 A5.000	4	1910	910
192 A7.011	5	2446	956
192 A8.000	4	1910	910
192 A9.000	4	1910	910
192 B1.000	4	1910	912
192 B2.000	4	1368	864
192 B3.000	4	1598	882
192 B4.000	4	1910	912
192 B5.000	4	1910	910
194 A1.000	4	2198	946
198 A1.000	4	1368	866
198 A2.000	4	1598	884
198 A3.000	4	1598	882
198 A4.000	4	1368	866
198 A5.000	4	1956	924
198 A6.000	4	1598	884
198 A7.000	4	1368	866
198 A8.000	4	1956	924
199 A1.000	4	1248	860
199 A2.000	4	1248	856



199 A3.000	4	1248	856
199 A4.000	4	1242	852
199 A5.000	4	1910	912
199 A6.000	4	1368	866
199 A7.000	4	1368	866
199 A9.000	4	1248	860
199 B1.000	4	1248	858
199 B2.000	4	1248	854
199 B4.000	4	1248	858
199 B5.000	4	1598	884
199 B6.000	2	875	836
199 B7.000	2	875	836
199 B8.000	4	1248	858
199 B9.000	4	1242	844
220 A 2.000	4	1581	880
223 A3.011	4	1242	852
223 A5.000	4	1242	852
223 A6.000	4	1910	914
223 A7.000	4	1910	914
223 A9.000	4	1248	858
223 B1.000	4	1910	914
223 B2.000	4	1910	914
225 A2.000	4	1248	860
230 A2.000	4	1929	922
230 A3.000	4	1929	922
230 A4.000	4	1929	922
250 A1.000	4	1956	924
250 A2.000	4	1956	924
263 A1.000	4	1956	924
263 A2.000	4	1248	860
263 A3.000	4	1598	884
263 A4.000	4	1598	884
263 A5.000	4	1598	884
263 A6.000	4	1248	860
263 A7.000	4	1598	884
263 A8.000	4	1598	884
263 A9.000	4	1598	884



280 A1.000	4	1929	922
310 A5.011	4	1598	884
312 A1.000	4	1368	866
312 A2.000	2	875	838
312 A3.000	4	1368	866
312 A4.000	2	964	840
312 A5.000	2	875	836
312 A6.000	2	964	840
312 A7.000	2	875	836
312 A8.000	4	1248	860
312 B1.000	4	1248	860
312 B2.000	4	1248	860
312 B5.000	4	1248	860
323 B6.600	4	1368	868
330 A1.000	4	1248	860
350 A1.000	4	1368	868
350 A2.000	4	1598	884
350 A3.000	4	1598	884
370 A0.011	4	1747	894
463 37 566	2	875	838
463 41 162	3	999	842
4D56	4	2477	956
4HJ (PUMA C)	4	2198	946
4HP	4	2179	944
4HR	4	2179	944
4HS	4	2179	944
4HT (DW12BTED4)	4	2179	944
4HU (P22DTE)	4	2198	946
4HV	4	2198	946
4HW (DW12ATED4)	4	2179	944
4N15	4	2442	954
552 53 268	4	1368	868
552 60 384	4	1598	866
552 63 087	4	1956	924
552 63 088	4	1956	924
552 63 623	4	1368	870



552 63 624	4	1368	870
552 63 842	4	1598	886
552 66 963	4	1248	860
552 68 023	3	999	842
552 68 036	4	1598	886
552 68 176	4	1332	862
552 77 701	4	1368	870
552 80 444	4	1598	886
552 83 099	4	1956	926
552 83 775	4	1248	860
8140.23.2200	4	2800	962
8140.27	4	2500	956
8140.27.2100	4	2500	956
8140.43	4	2800	964
8140.43N	4	2800	964
8140.43S	4	2798	962
8140.47	4	2500	958
8140.47R	4	2500	958
8140.61	4	2445	954
8140.61.204	4	2445	954
8140.63	4	2800	966
8140.67	4	2500	958
8144.61.200	4	2445	954
8144.61.500.81	4	2445	954
8144.67	4	2500	960
8144.97	4	2499	956
8144.97.2200	4	2499	956
8144.97.2400	4	2499	956
8144.97 S	4	2500	960
8144.97 Y	4	2500	960
835 C1.000	4	1581	878
836 A4.000	4	1372	874
839 A5.000	5	2387	952
843 A1.000	4	1368	870
844 A2.000	4	1956	924
844 A3.000	4	1598	884
937 A4.000	4	1910	914

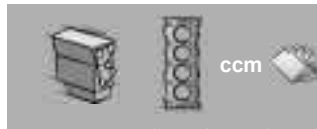

937 A5.000	4	1910	916
937 A7.000	4	1910	916
939 A1.000	4	1910	918
939 A2.000	4	1910	916
939 A3.000	5	2387	954
939 A4.000	4	1796	894
939 A7.000	4	1910	918
939 A8.000	4	1910	918
939 B5.000	4	1956	926
940 A5.000	4	1956	926
940 B7.000	4	1368	870
940 C1.000	4	1598	886
955 A2.000	4	1368	872
955 A3.000	4	1598	886
955 A4.000	4	1598	884
955 A6.000	4	1368	872
955 A8.000	4	1368	872
955 B2.000	4	1248	860
9H07 (DV6UC)	4	1560	876
9HM (DV6UC)	4	1560	876
9HU	4	1560	876
D19AA	4	1910	920
D20AA	4	1956	926
D8B	4	1905	898
D8B (XUD9TE)	4	1905	898
D9B	4	1905	900
D9B (XUD9A)	4	1905	902
DHX	4	1905	898
DHX (XUD9TE)	4	1905	898
DHX (XUD9TF/L)	4	1905	898
DJY	4	1905	900
DJY (XUD9)	4	1905	902
DW10BTED4	4	1997	932
EAF	4	1368	872
EAM	4	1368	872
ED3	4	2360	952

EDG	4	2360	952
ERB	6	3604	968
F1AE0481C	4	2287	948
F1AE0481D	4	2287	948
F1AE0481N	4	2287	948
F1AE0481T	4	2287	950
F1AE3481D	4	2287	950
F1AE3481E	4	2287	950
F1AE3481G	4	2287	950
F1AGL4111	4	2287	952
F1AGL4112	4	2287	952
F1AGL4113	4	2287	952
F1AGL4114	4	2287	952
F1AGL411A	4	2287	952
F1AGL411B	4	2287	952
F1AGL411C	4	2287	952
F1AGL411D	4	2287	952
F1CE0441A	4	2999	966
F1CE0481D	4	2999	968
F1CE3481E	4	2999	968
F1CE3481M	4	2999	968
F1CE3481N	4	2999	968
F1CFA401A	4	2999	968
F1CFA401C	4	2999	968
KFT	4	1360	864
KFV	4	1360	864
LFW (XU7JP)	4	1761	894
M020 AA.09.0	4	903	838
M16A	4	1586	880
P8C	4	2088	942
R9M 408	4	1598	888
R9M 413	4	1598	888
R9M 450	4	1598	888
R9M 452	4	1598	888
RFL	4	1998	938
RFN (EW10J4)	4	1997	928
RFU (XU10J2C)	4	1998	938









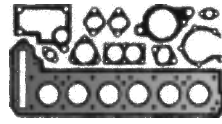
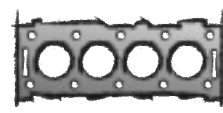

RFV	4	1998	940
RFW	4	1998	938
RGX (XU10J2CTE)	4	1998	940
RH02	4	1997	928
RHG	4	1997	928
RHH	4	1997	928
RHK	4	1997	932
RHK (DW10UTED4)	4	1997	930
RHM (DW10ATED4)	4	1997	930
RHR	4	1997	932
RHV	4	1997	934
RHW (DW10ATED4)	4	1997	930
RHX	4	1997	936
RHZ	4	1997	936
WJY (DW8)	4	1868	896
WJY (DW8B)	4	1868	896
WJZ (DW8)	4	1868	896
XFW	6	2946	966

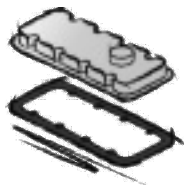



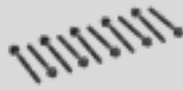
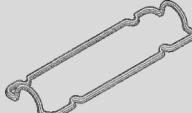

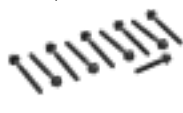

















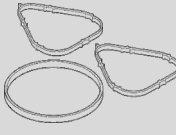

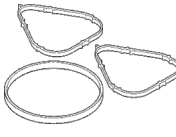



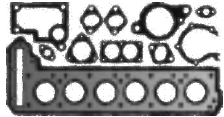
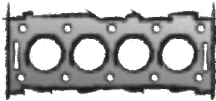

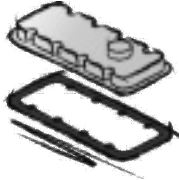

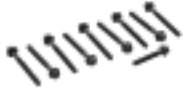

FIAT

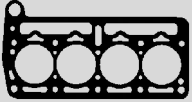

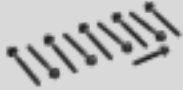



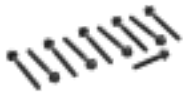











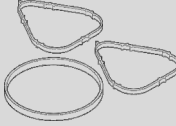







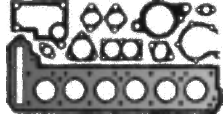
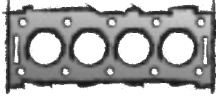

FIAT

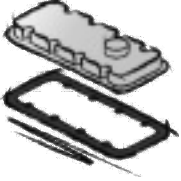

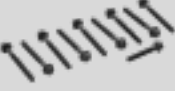
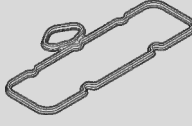





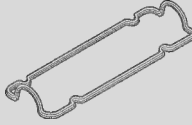



<p>FIAT</p> 				
<p>126 A2.000/048 2 Cyl. 704 ccm Cyl. 80,0 Ø</p> <p>126 09/1987 → 06/1996</p>		<p>144.570 7751688 46444964 1,20 mm $\frac{\pm}{\pm}$ 81 Ø</p> 		
<p>170 A.000/046 2 Cyl. 704 ccm Cyl. 80,0 Ø</p> <p>Cinquecento 12/1991 → 01/1998</p>	<p>ES⊕ 710.160 5892416</p>	<p>144.570 7751688 46444964 1,20 mm $\frac{\pm}{\pm}$ 81 Ø</p> 		
<p>156 A4.000/048 4 Cyl. 770 ccm Cyl. 65,0 Ø</p> <p>Panda 01/1986 → 10/2003</p>	<p>ES⊕ 144.520 5892369</p>	<p>144.460 7640783 1,65 mm $\frac{\pm}{\pm}$ 66 Ø</p> 	<p>ZKS 760.720 7696197 (10x) M 9x1,25x96</p> 	<p>591.076 7688450</p> 
<p>127 A1.024 4 Cyl. 843 ccm Cyl. 65,0 Ø</p> <p>133 06/1975 → 04/1981</p>		<p>985.880 7631023 1,12 mm $\frac{\pm}{\pm}$ 66 Ø</p>  <p>144.420 5891781 1,65 mm $\frac{\pm}{\pm}$ 66 Ø</p> 	<p>ZKS 148.110 46475573 (9x) +46475574 (1x) M 9x1,25x56/91</p> 	<p>154.016 4145587</p> 
<p>199 B6.000 199 B7.000 2 Cyl. 875 ccm Cyl. 80,5 Ø</p> <p>500 10/2013 →</p> <p>500 L 09/2012 →</p> <p>Punto 07/2013 →</p>	<p>ES⊕ 925.990 CS* 299.401 OKS 888.410 55224603</p>	<p>816.160 ● 55254545</p> 	<p>ZKS 949.350 55225419 (6x) M 9x1,25x120</p>	<p>ZKHS 707.120</p>
<p>312 A5.000 312 A7.000 2 Cyl. 875 ccm Cyl. 80,5 Ø</p> <p>500 12/2013 →</p> <p>Panda 02/2012 →</p>	<p>CS* 299.401 OKS 888.410 55224603</p>		<p>ZKS 949.350 55225419 (6x) M 9x1,25x120</p>	









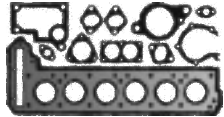
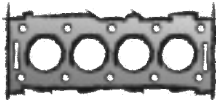

			<p>a) </p> <p>b) </p>	<p>K: </p> <p>N: </p>	
<p>294.110 7553637 FPM 2x</p>					
<p>294.110 7553637 FPM 2x</p>		<p>698.920 7755742</p> 	<p>b) 587.100 7734022 M 22x1,5x13</p>		
<p>VAS 825.042 FPM 701.289 46436047 FPM 8x</p>	<p>435.510 7749709 4x</p> 	<p>375.160 46754320</p> 	<p>a) 030.793 Dirko HT b) 587.100 7734022 M 22x1,5x13</p>	<p>K:→ 440.780 40004280 AW/BS LD ACM 64x80x8 N:← 440.720 40004240 ASW RD ACM 30x42x7 N:← 505.838 60809849 ASW RD FPM 30x42x7</p>	
	<p>480.650 7742042</p> 		<p>a) OWS 918.024 5882343</p> 	<p>K:→ 440.780 40004280 AW/BS LD ACM 64x80x8</p>	
<p>VAS 710.840 FPM</p>	<p>912.980 55246658</p> 	<p>AAS 008.170 77365787</p> 	<p>a) 030.793 Dirko HT b) 878.110 incl. 110.604 55184773 M 12x1,25x13 b) 110.604 10261060 CU A 12x16x1,5</p>	<p>K:← 069.590 7628850 AW/BS RD FPM 31x41x7 K:→ 135.110 55229956 ASW LD FPM/ACM 85x105x9</p>	
<p>VAS 710.840 FPM</p>	<p>574.630 55230477</p> 	<p>AAS 008.170 77365787</p> 	<p>a) 030.793 Dirko HT b) 878.110 incl. 110.604 55184773 M 12x1,25x13 b) 110.604 10261060 CU A 12x16x1,5</p>	<p>K:← 069.590 7628850 AW/BS RD FPM 31x41x7 K:→ 135.110 55229956 ASW LD FPM/ACM 85x105x9</p>	<p>TLS 002.360</p>

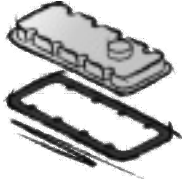

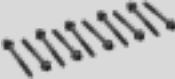



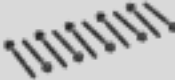
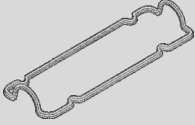

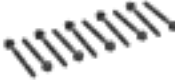
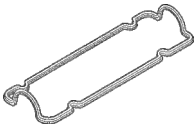





<p>FIAT</p> 				
<p>312 A2.000 463 37 566</p> <p>2 Cyl. 875 ccm Cyl. 80,5 Ø</p> <p>500 09/2009 →</p> <p>500 L 03/2013 →</p> <p>Panda 02/2012 →</p> <p>Punto 03/2012 →</p>	<p>ES⊕ 047.221 Euro 5 CS* 299.401 OKS 888.410 55224603</p>	<p>655.980 55239522 0,72 mm ± 82,7 Ø</p> 	<p>ZKS 949.350 55225419 (6x) M 9x1,25x120</p>	<p>ZKHS 005.660</p> 
<p>1170 A1.000/046</p> <p>4 Cyl. 899 ccm Cyl. 65,0 Ø</p> <p>Cinquecento 07/1991 → 07/1999</p> <p>Panda 04/1992 → 12/1996</p> <p>Seicento 11/1997 → 01/2010</p>	<p>S⊕* 710.232 5892407 →02/1998 ES⊕ 710.242 5892408</p>	<p>710.251 46462481 1,20 mm ± 65,9 Ø</p>  <p>180.140 46402972 1,50 mm ± 65,9 Ø</p> 	<p>ZKS 148.110 46475573 (9x) +46475574 (1x) M 9x1,25x56/91</p> 	<p>332.130 7660759</p> 
<p>100 GF 000 100 GL.000/048 100 GL3.000 M020 AA.09.0</p> <p>4 Cyl. 903 ccm Cyl. 65,0 Ø</p> <p>127 06/1971 → 12/1984</p> <p>147 04/1977 → 12/1981</p> <p>900 01/1978 → 01/1986</p> <p>Fiorino 10/1977 → 10/1986</p> <p>Panda 10/1980 → 06/1994</p> <p>Uno 02/1984 → 08/1989</p>	<p>ES⊕ 144.440 incl. 985.880 5892386</p>	<p>985.880 7631023 1,12 mm ± 66 Ø</p>  <p>144.420 5891781 1,65 mm ± 66 Ø</p> 	<p>ZKS 148.110 46475573 (9x) +46475574 (1x) M 9x1,25x56/91</p> 	<p>154.016 4145587</p> 
<p>146 A.000/048 146 A1.000</p> <p>4 Cyl. 903 ccm Cyl. 65,0 Ø</p> <p>Duna 07/1991 → 10/1995</p> <p>Panda 10/1980 → 06/1994</p> <p>Uno 03/1983 → 07/1996</p>	<p>ES⊕ 144.440 incl. 985.880 5892386</p>	<p>985.880 7631023 1,12 mm ± 66 Ø</p>  <p>144.420 5891781 1,65 mm ± 66 Ø</p> 	<p>ZKS 148.110 46475573 (9x) +46475574 (1x) M 9x1,25x56/91</p> 	<p>154.016 4145587</p> 











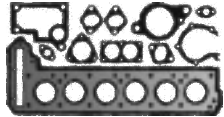
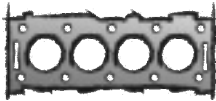

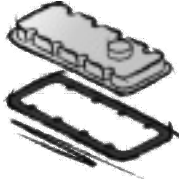
			<p>a) </p> <p>b) </p>	<p>K: </p> <p>N: </p>	
<p>VAS 710.840 FPM</p>	<p>574.630 55230477</p> 	<p>AAS 008.170 77365787</p> 	<p>a) 030.793 Dirko HT</p> <p>b) 878.110 incl. 110.604 55184773 M 12x1,25x13</p> <p>b) 110.604 10261060 CU A 12x16x1,5</p>	<p>K:← 069.590 7628850 AW/BS RD FPM 31x41x7</p> <p>K:→ 135.110 55229956 ASW LD FPM/ACM 85x105x9</p>	<p>TLS 002.360</p>
<p>VAS 825.042 FPM</p> <p>701.289 46436047 FPM 8x</p>	<p>480.650 7742042</p> 		<p>a) 419.530 7716337 →02/1998</p>  <p>b) 587.100 7734022 M 22x1,5x13</p>	<p>K:← 757.497 40004750 ASW RD FPM 42x56x7 Mot. 12881→</p> <p>K:→ 440.780 40004280 AW/BS LD ACM 64x80x8</p>	
<p>VAS 825.042 FPM</p> <p>701.289 46436047 FPM 8x</p>	<p>480.650 7742042</p> 		<p>a) OWS 918.024 5882343</p> 	<p>K:→ 440.780 40004280 AW/BS LD ACM 64x80x8</p>	
<p>VAS 825.042 FPM</p> <p>701.289 46436047 FPM 8x</p>	<p>480.650 7742042</p> 		<p>a) OWS 918.024 5882343 →Mot. 8064870</p>  <p>a) 419.530 7716337 Mot. 8064871→</p>  <p>b) 587.100 7734022 M 22x1,5x13</p>	<p>K:→ 440.780 40004280 AW/BS LD ACM 64x80x8</p>	

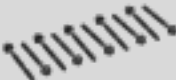
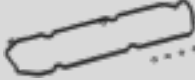



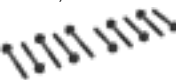

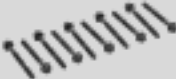
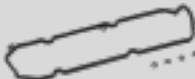





<p>FIAT</p> 				
<p>170 A1.000/046</p> <p>4 Cyl. 903 ccm Cyl. 65,0 Ø</p> <p>Cinquecento 07/1991 → 09/1994</p>	<p>S⊕* 710.232 5892407</p> <p>ES⊕ 710.242 5892408</p>	<p>710.251 46462481 1,20 mm $\frac{\pm}{\pm}$ 65,9 Ø</p>  <p>180.140 46402972 1,50 mm $\frac{\pm}{\pm}$ 65,9 Ø</p> 	<p>ZKS 148.110 46475573 (9x) +46475574 (1x) M 9x1,25x56/91</p> 	<p>332.130 7660759</p> 
<p>312 A4.000 312 A6.000</p> <p>2 Cyl. 964 ccm Cyl. 83,5 Ø</p> <p>500 09/2012 →</p> <p>Panda 02/2012 →</p>	<p>ES⊕ 912.430</p> <p>CS* 299.401</p> <p>OKS 888.410 55224603</p>	<p>878.490 55241143 1,20 mm $\frac{\pm}{\pm}$ 84 Ø</p>	<p>ZKS 949.350 55225419 (6x) M 9x1,25x120</p>	<p>ZKHS 707.120</p>
<p>146 A2.166 146 A7.011 146 B4.000/011 146 C4.011 146 C8.000</p> <p>4 Cyl. 994 ccm Cyl. 76,0 Ø</p> <p>Fiorino 01/1994 → 12/1996</p> <p>Uno 08/1990 → 06/2001</p>		<p>399.630 46541379 1,90 mm $\frac{\pm}{\pm}$ 77 Ø</p> 		
<p>146 E1.011</p> <p>4 Cyl. 999 ccm Cyl. 70,0 Ø</p> <p>Mille 01/2010 → 12/2013</p> <p>Palio 12/2011 → 12/2017</p> <p>Uno 06/2005 → 12/2009</p>		<p>492.660 55205675</p> 	<p>ZKS 760.720 7696197 (10x) M 9x1,25x96</p> 	
<p>141 C2.000 156 A2.000/0157/048/050/100/146/246 156 A3.000/100</p> <p>4 Cyl. 999 ccm Cyl. 70,0 Ø</p> <p>Fiorino 11/1992 → 04/1996</p> <p>Panda 01/1985 → 02/2004</p> <p>Uno 10/1984 → 12/2003</p>	<p>ES⊕ 144.552 5892375</p>	<p>144.470 7777153 1,65 mm $\frac{\pm}{\pm}$ 71 Ø</p>  <p>180.180 5894974 1,85 mm $\frac{\pm}{\pm}$ 71 Ø</p> 	<p>ZKS 760.720 7696197 (10x) M 9x1,25x96</p> 	<p>591.076 7688450</p> 









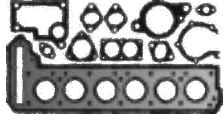
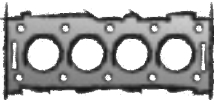

			<p>a) </p> <p>b) </p>	<p>K: </p> <p>N: </p>	
<p>VAS 825.042 FPM 701.289 46436047 FPM 8x</p>			<p>a) 419.530 7716337</p>  <p>b) 587.100 7734022 M 22x1,5x13</p>	<p>K:← 757.497 40004750 ASW RD FPM 42x56x7 Mot. 12881→</p> <p>K:→ 440.780 40004280 AW/BS LD ACM 64x80x8</p>	
<p>VAS 710.840 FPM</p>	<p>911.240 51854364</p> 	<p>AAS 888.320 77366308</p>	<p>a) 030.793 Dirko HT</p> <p>b) 878.110 incl. 110.604 55184773 M 12x1,25x13</p> <p>b) 110.604 10261060 CU A 12x16x1,5</p>	<p>K:← 069.590 7628850 AW/BS RD FPM 31x41x7</p> <p>K:→ 135.110 55229956 ASW LD FPM/ACM 85x105x9</p>	
<p>VAS 702.706 FPM 553.190 5930415 FPM 8x</p>			<p>b) 587.100 7734022 M 22x1,5x13</p>	<p>K:← 440.760 40004950 AW/B RD FPM 40x56x7</p> <p>N:← 440.750 40004940 AW/BS RD FPM 30x52x7</p>	
<p>VAS 825.042 FPM 701.289 46436047 FPM 8x</p>	<p>375.070 55199355</p> 				
<p>VAS 825.042 FPM 701.289 46436047 FPM 8x</p>	<p>375.070 55199355</p> 	<p>375.160 46754320</p> 	<p>a) 030.793 Dirko HT</p> <p>b) 587.100 7734022 M 22x1,5x13</p>	<p>K:← 440.710 40004200 A/BS RD FPM 23x35x7</p> <p>K:→ 440.810 40004190 A/BS LD FPM 70x88x8</p> <p>N:← 440.720 40004240 ASW RD ACM 30x42x7</p> <p>N:← 505.838 60809849 ASW RD FPM 30x42x7</p>	



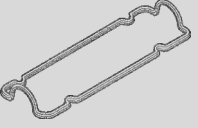
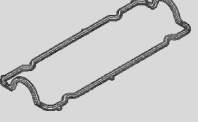
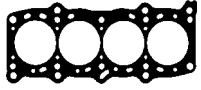

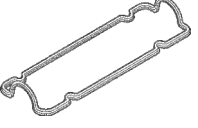



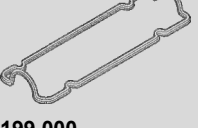
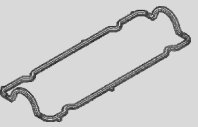
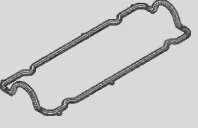





<p>FIAT</p> 				
<p>178 D8.011</p> <p>4 Cyl. 999 ccm Cyl. 70,0 Ø</p> <p>Palio 08/2000 → 02/2003</p> <p>Siena 03/2000 → 02/2003</p>	<p>CS* 309.990</p>	<p>104.316 46541740</p> 	<p>ZKS 111.590 7795992 (10x) M 9x1,25x87</p> 	<p>199.010 55194045</p> 
<p>463 41 162 552 68 023</p> <p>3 Cyl. 999 ccm Cyl. 70,0 Ø</p> <p>500 01/2020 →</p> <p>Argo 06/2017 →</p> <p>Mobi 01/2017 →</p> <p>Panda 01/2020 →</p> <p>Uno 09/2016 →</p>	<p>ES 889.650</p>	<p>360.130 55267849 0,72 mm $\frac{2}{3}$ 71 Ø</p>		<p>574.760 7090228</p> 
<p>146 C3.000 156 C.046 176 A6.000 176 B2.000 178 B9.033</p> <p>4 Cyl. 1108 ccm Cyl. 70,0 Ø</p> <p>Cinquecento 10/1994 → 02/1998</p> <p>Palio 07/1997 → 10/2003</p> <p>Panda 05/1991 → 07/2004</p> <p>Punto 09/1993 → 02/2000</p> <p>Seicento 01/1998 → 01/2010</p> <p>Uno 01/1990 → 12/1993</p>	<p>S⊕* 529.461 5893658 +7724665 +40004240 +40004200 +40004190 →Mot. 6315750</p> <p>ES⊕ 529.471 5893659 +40004240</p>	<p>144.470 7777153 1,65 mm $\frac{2}{3}$ 71 Ø</p>  <p>180.180 5894974 1,85 mm $\frac{2}{3}$ 71 Ø</p> 	<p>ZKS 760.720 7696197 (10x) M 9x1,25x96</p> 	<p>591.076 7688450</p> 
<p>160 A3.000</p> <p>4 Cyl. 1108 ccm Cyl. 70,0 Ø</p> <p>Tipo 01/1988 → 10/1991</p> <p>Uno 04/1986 → 06/2006</p>	<p>ES⊕ 144.552 5892375</p>	<p>144.470 7777153 1,65 mm $\frac{2}{3}$ 71 Ø</p>  <p>180.180 5894974 1,85 mm $\frac{2}{3}$ 71 Ø</p> 	<p>ZKS 760.720 7696197 (10x) M 9x1,25x96</p> 	<p>591.076 7688450</p> 









			<p>a) </p> <p>b) </p>	<p>K: </p> <p>N: </p>	
<p>069.630 46470334 FPM 16x</p>	<p>339.260 46526271</p> 		<p>a) 030.793 Dirko HT</p> <p>b) 587.100 7734022 M 22x1,5x13</p>	<p>K:← 069.540 46404094 AW/BS RD FPM 27x37x7</p> <p>K:→ 375.320 46539824 SP LD FPM 74</p> <p>N:← 290.710 55195339 AW/BS RD FPM 40x55x7</p>	
	<p>574.770 52109530</p> 	<p>535.330 7090209 3x</p> 	<p>a) 036.164 Dirko HT / EU</p> <p>a) 510.031 Dirko HT / USA/CDN/MEX</p> <p>a) 527.291 Dirko HT / RU</p> <p>a) 648.661 Dirko HT / BR</p> <p>b) 298.480 M 14x1,5x18</p>	<p>K:← 331.530 7091279 ASW RD FPM 34x47x5,5</p> <p>K:→ 247.290 55267742 AS LD FPM 80x96x8</p>	
<p>VAS 825.042 FPM</p> <p>701.289 46436047 FPM 8x</p>	<p>375.070 55199355</p> 	<p>375.160 46754320</p> 	<p>a) 030.793 Dirko HT</p> <p>b) 587.100 7734022 M 22x1,5x13</p>	<p>K:← 440.710 40004200 A/BS RD FPM 23x35x7</p> <p>K:→ 440.810 40004190 A/BS LD FPM 70x88x8 →Mot. 6315750</p> <p>K:→ 069.600 71754491 AW/BS LD FPM 74x88x8 Mot. 6315751→</p> <p>N:← 440.720 40004240 ASW RD ACM 30x42x7</p> <p>N:← 505.838 60809849 ASW RD FPM 30x42x7</p>	
<p>VAS 825.042 FPM</p> <p>701.289 46436047 FPM 8x</p>	<p>375.070 55199355</p> 	<p>375.160 46754320</p> 	<p>a) 030.793 Dirko HT</p> <p>b) 587.100 7734022 M 22x1,5x13</p>	<p>K:← 440.710 40004200 A/BS RD FPM 23x35x7</p> <p>K:→ 440.810 40004190 A/BS LD FPM 70x88x8</p> <p>N:← 440.720 40004240 ASW RD ACM 30x42x7</p> <p>N:← 505.838 60809849 ASW RD FPM 30x42x7</p>	

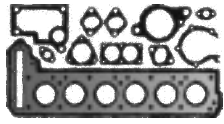
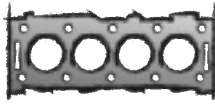

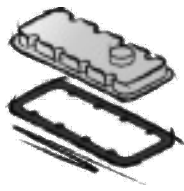

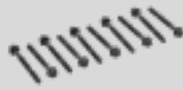

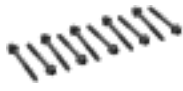



<p>FIAT</p> 				
<p>187 A1.000</p> <p>4 Cyl. 1108 ccm Cyl. 70,0 Ø</p> <p>Palio 06/2006 → 11/2011</p> <p>Panda 02/1995 →</p> <p>Seicento 01/1998 → 01/2010</p>	<p>S⊕* 180.190 71718389 Panda (141) →Mot. 2533527</p> <hr/> <p>Seicento (187) →Mot. 2543169</p> <p>ES⊕ 180.230 71718390 Panda (141) →Mot. 2533527</p> <hr/> <p>Seicento (187) →Mot. 2543169</p> <p>ES⊕ 247.270 →Mot. 2888157</p> <hr/> <p>Panda (141) Mot. 2533528→</p> <hr/> <p>Seicento (187) Mot. 2543170→</p> <p>CS* 431.560 71736317</p>	<p>144.470 7777153 1,65 mm $\frac{\pm}{\pm}$ 71 Ø </p> <hr/> <p>180.180 5894974 1,85 mm $\frac{\pm}{\pm}$ 71 Ø </p>	<p>ZKS 760.720 7696197 (10x) M 9x1,25x96</p> 	<p>ZKHS 724.280 Mot. 2888158→</p>  <p>199.000 46759989 →06/2002</p>  <p>505.060 71740678 Mot. 2888158→</p>  <p>399.570 73502863 07/2002→ →Mot. 2888157</p> 
<p>146 A6.000 146 A9.000</p> <p>4 Cyl. 1116 ccm Cyl. 76,0 Ø</p> <p>Duna 01/1987 → 12/1991</p> <p>Fiorino 11/1986 → 12/1993</p> <p>Penny 01/1986 → 12/1990</p>		<p>399.630 46541379 1,90 mm $\frac{\pm}{\pm}$ 77 Ø </p>	<p>ZKS 760.870 46430687 (5x) +46430688 (5x) M 10x1,25x84/99</p> 	
<p>169 A4.000 199 B9.000</p> <p>4 Cyl. 1242 ccm Cyl. 70,8 Ø</p> <p>500 07/2007 →</p> <p>Grande Punto 09/2010 →</p> <p>Panda 03/2010 →</p> <p>Punto 03/2012 →</p> <p>Punto Evo 10/2009 → 02/2012</p>	<p>ES⊕ 037.461</p> <p>CS* 431.560 71736317</p>	<p>040.554 55183371 0,49 mm $\frac{\pm}{\pm}$ 72,4 Ø </p>	<p>ZKS 760.720 7696197 (10x) M 9x1,25x96</p> 	<p>ZKHS 724.280</p>  <p>505.060 71740678</p> 





			<p>a) </p> <p>b) </p>	<p>K: </p> <p>N: </p>	
<p>VAS 825.042 FPM Panda (141) →Mot. 2533527</p> <hr/> <p>Seicento (187) →Mot. 2543169</p> <p>VAS 688.050 FPM Panda (141) Mot. 2533528→</p> <hr/> <p>Seicento (187) Mot. 2543170→</p> <p>701.289 46436047 FPM E A 8x</p> <hr/> <p>Panda (169) →Mot. 2533527</p> <hr/> <p>Seicento (187) →Mot. 2543169</p> <p>476.691 55190344 FPM E A 8x</p> <hr/> <p>Panda (169) Mot. 2533528→</p> <hr/> <p>Seicento (187) Mot. 2543170→</p>	<p>375.070 55199355</p> 	<p>AAS 728.670 77365317</p> 	<p>a) 030.793 Dirko HT</p> <p>b) 587.100 7734022 M 22x1,5x13</p>	<p>K:← 440.710 40004200 A/BS RD FPM 23x35x7 →Mot. 2888157</p> <p>K:← 069.540 46404094 AW/BS RD FPM 27x37x7 Mot. 2888158→</p> <p>K:→ 069.600 71754491 AW/BS LD FPM 74x88x8</p> <p>K:→ 440.810 40004190 A/BS LD FPM 70x88x8</p> <p>N:← 440.720 40004240 ASW RD ACM 30x42x7 →Mot. 2888157</p> <p>N:← 505.838 60809849 ASW RD FPM 30x42x7 →Mot. 2888157</p> <p>N:← 688.580 55189997 AW/BS RD FPM 31x55x7 Mot. 2888158→</p>	
<p>VAS 294.250 FPM</p> <p>294.110 7553637 FPM 8x</p>			<p>b) 587.100 7734022 M 22x1,5x13</p>	<p>K:← 440.760 40004950 AW/B RD FPM 40x56x7</p> <p>N:← 440.750 40004940 AW/BS RD FPM 30x52x7</p>	
<p>VAS 688.050 FPM</p> <p>476.691 55190344 FPM 8x</p>	<p>375.070 55199355</p> 	<p>AAS 444.760 77363787</p> 	<p>a) 030.793 Dirko HT</p> <p>b) 587.100 7734022 M 22x1,5x13</p>	<p>K:← 069.540 46404094 AW/BS RD FPM 27x37x7</p> <p>K:→ 069.600 71754491 AW/BS LD FPM 74x88x8</p> <p>N:← 290.710 55195339 AW/BS RD FPM 40x55x7</p>	





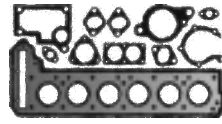
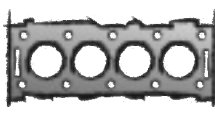

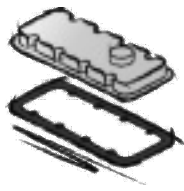

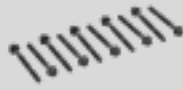
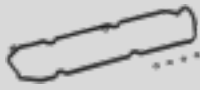
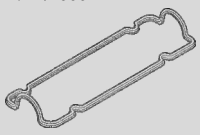
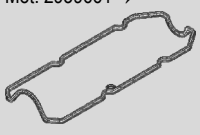
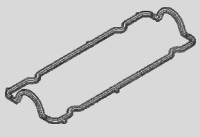
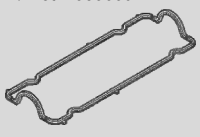

<p>FIAT</p> 				
<p>176 A8.000</p> <p>4 Cyl. 1242 ccm Cyl. 70,8 Ø</p> <p>Palio 06/1998 →</p> <p>Punto 10/1993 → 09/1999</p>	<p>S⊕* 710.291 5893662 →11/1999</p> <p>ES⊕ 710.301 5893663 →11/1999</p>	<p>710.280 46434102</p> 	<p>ZKS 760.720 7696197 (10x) M 9x1,25x96</p> 	<p>591.076 7688450 →11/1999</p>  <p>199.000 46759989 12/1999→</p> 
<p>176 A7.000 176 B1.000 176 B4.000 178 E2.000</p> <p>4 Cyl. 1242 ccm Cyl. 70,8 Ø</p> <p>Palio 06/1998 →</p> <p>Punto 09/1993 → 06/2000</p>	<p>S⊕* 710.261 5893660 →11/1999</p> <p>ES⊕ 710.271 5863661 →11/1999</p>	<p>710.280 46434102</p> 	<p>ZKS 760.720 7696197 (10x) M 9x1,25x96</p> 	<p>591.076 7688450 →11/1999</p>  <p>199.000 46759989 12/1999→</p> 
<p>178 B5.000 178 B7.045 178 C4.066</p> <p>4 Cyl. 1242 ccm Cyl. 70,8 Ø</p> <p>Fiorino 01/2004 →</p> <p>Palio 04/1996 →</p> <p>Siena 09/1998 → 12/2012</p> <p>Strada 06/1999 →</p>	<p>S⊕* 710.291 5893662 →11/1999</p> <p>ES⊕ 710.301 5893663 →11/1999</p> <p>ES⊕ 427.910 09/2003→ →Mot. 2533527</p>	<p>710.280 46434102 →08/2003</p> <p>040.554 55183371 0,49 mm $\frac{1}{16}$ 72,4 Ø</p> <p>09/2003→</p>  	<p>ZKS 760.720 7696197 (10x) M 9x1,25x96</p> 	<p>591.076 7688450 →11/1999</p>  <p>199.000 46759989 12/1999→ →06/2002</p>  <p>399.570 73502863 07/2002→</p> 









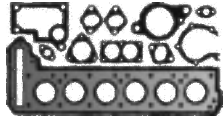
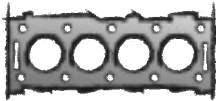

			<p>a) </p> <p>b) </p>	<p>K: </p> <p>N: </p>	
<p>VAS 825.042 FPM 701.289 46436047 FPM 8x</p>	<p>375.070 55199355 </p>	<p>375.120 46757318 </p>	<p>a) 030.793 Dirko HT</p> <p>b) 587.100 7734022 M 22x1,5x13</p>	<p>K:← 440.710 40004200 A/BS RD FPM 23x35x7</p> <p>K:→ 069.600 71754491 AW/BS LD FPM 74x88x8</p> <p>N:← 440.720 40004240 ASW RD ACM 30x42x7</p> <p>N:← 505.838 60809849 ASW RD FPM 30x42x7</p>	
<p>VAS 825.042 FPM 701.289 46436047 FPM 8x</p>	<p>375.070 55199355 </p>	<p>375.160 46754320 </p>	<p>a) 030.793 Dirko HT</p> <p>b) 587.100 7734022 M 22x1,5x13</p>	<p>K:← 440.710 40004200 A/BS RD FPM 23x35x7</p> <p>K:→ 069.600 71754491 AW/BS LD FPM 74x88x8</p> <p>N:← 440.720 40004240 ASW RD ACM 30x42x7</p> <p>N:← 505.838 60809849 ASW RD FPM 30x42x7</p>	
<p>VAS 825.042 FPM →Mot. 2533527</p> <p>VAS 688.050 FPM Mot. 2533528→</p> <p>701.289 46436047 FPM →Mot. 2533527 8x</p> <p>476.691 55190344 FPM Mot. 2533528→ 8x</p>	<p>375.070 55199355 </p>	<p>375.120 46757318 </p>	<p>a) 030.793 Dirko HT</p> <p>b) 587.100 7734022 M 22x1,5x13</p>	<p>K:← 440.710 40004200 A/BS RD FPM 23x35x7</p> <p>K:→ 069.600 71754491 AW/BS LD FPM 74x88x8</p> <p>N:← 440.720 40004240 ASW RD ACM 30x42x7</p> <p>N:← 505.838 60809849 ASW RD FPM 30x42x7</p>	

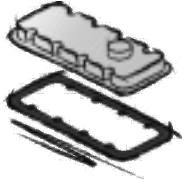
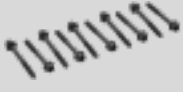
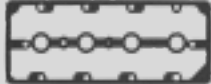

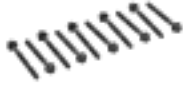
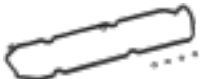

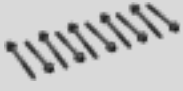
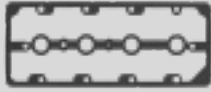

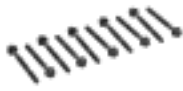







<p>FIAT</p> 				
<p>178 E8.011 178 E9.011</p> <p>4 Cyl. 1242 ccm Cyl. 70,8 Ø</p> <p>Fiorino 01/2007 → 12/2013</p> <p>Palio 09/2002 →</p> <p>Siena 09/2002 → 12/2009</p> <p>Strada 06/2004 →</p> <p>Uno 01/2004 →</p>		<p>040.554 55183371 0,49 mm $\frac{+}{-}$ 72,4 Ø</p> 	<p>ZKS 760.720 7696197 (10x) M 9x1,25x96</p> 	<p>807.890 46748519</p>
<p>176 B9.000 182 B2.000</p> <p>4 Cyl. 1242 ccm Cyl. 70,8 Ø</p> <p>Brava 12/1998 → 12/2002</p> <p>Bravo 12/1998 → 10/2000</p> <p>Marea 10/1998 → 05/2002</p> <p>Punto 04/1997 → 06/2000</p>	<p>ES⊕ 180.380 71711936</p> <p>CS* 431.560 71736317</p>	<p>180.270 46434596 1,65 mm $\frac{+}{-}$ 71,4 Ø</p> 	<p>ZKS 111.590 7795992 (10x) M 9x1,25x87</p> 	<p>199.010 55194045</p> 











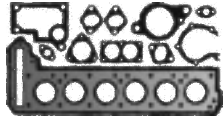
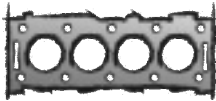

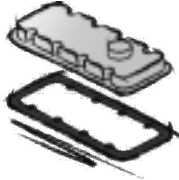

			<p>a) </p> <p>b) </p>	<p>K: </p> <p>N: </p>	
<p>VAS 825.042 FPM 701.289 46436047 FPM 8x</p>	<p>375.070 55199355 </p>		<p>a) 030.793 Dirko HT b) 587.100 7734022 M 22x1,5x13</p>	<p>K:← 069.540 46404094 AW/BS RD FPM 27x37x7 N:← 505.838 60809849 ASW RD FPM 30x42x7</p>	
<p>069.630 46470334 FPM 16x</p>	<p>725.790 46757609 </p>	<p>728.960 46757321 </p>	<p>a) 030.793 Dirko HT b) 587.100 7734022 M 22x1,5x13</p>	<p>K:← 069.540 46404094 AW/BS RD FPM 27x37x7 K:→ 069.600 71754491 AW/BS LD FPM 74x88x8 N:← 290.710 55195339 AW/BS RD FPM 40x55x7</p>	

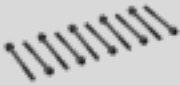
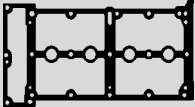



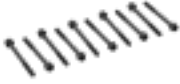
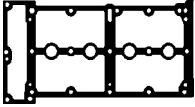



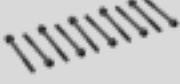
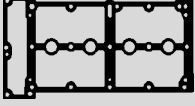







<p>FIAT</p> 				
<p>188 A4.000 4 Cyl. 1242 ccm Cyl. 70,8 Ø</p> <p>Palio 07/1997 → 10/2004</p> <p>Panda 09/2003 →</p> <p>Punto 09/1999 → 03/2012</p> <p>Siena 09/2001 → 12/2012</p> <p>Strada 04/2003 →</p> <p>Uno 08/2000 → 08/2009</p>	<p>S⊕* 180.250 71715869 +7688450 →08/2003</p> <p>ES⊕ 180.260 71716868 +7688450 →08/2003</p> <p>ES⊕ 505.730 Mot. 2533528 → →Mot. 2935742</p> <hr/> <p>Panda (169) →Mot. 2939660</p> <p>ES⊕ 732.970 Mot. 2935743 →</p> <hr/> <p>Panda (169) Mot. 2939661 →</p> <p>ES⊕ 431.470 09/2003 → →Mot. 2533527</p> <p>CS* 431.560 71736317</p>	<p>710.280 46434102 →08/2003</p>  <p>040.554 55183371 0,49 mm $\frac{1}{16}$ 72,4 Ø</p> 	<p>ZKS 760.720 7696197 (10x) M 9x1,25x96</p> 	<p>ZKHS 724.280 Mot. 2935743 →</p> <hr/> <p>Panda (169) Mot. 2939661 →</p>  <p>591.076 7688450 →11/1999</p>  <p>505.060 71740678 Mot. 2935743 →</p> <hr/> <p>Panda (169) Mot. 2939661 →</p>  <p>199.000 46759989 12/1999 → →06/2002</p>  <p>399.570 73502863 07/2002 →</p> <hr/> <p>→Mot. 2935742</p> <hr/> <p>Panda (169) →Mot. 2939660</p> 

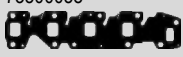
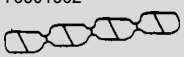



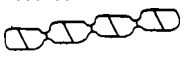

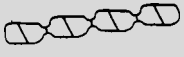



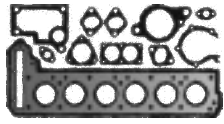
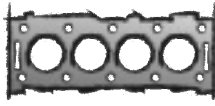

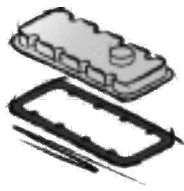

			<p>a) </p> <p>b) </p>	<p>K: </p> <p>N: </p>	
<p>VAS 825.042 FPM →Mot. 2533527</p> <p>VAS 688.050 FPM Mot. 2533528→</p> <p>701.289 46436047 FPM →Mot. 2533527 8x</p> <p>476.691 55190344 FPM Mot. 2533528→ 8x</p>	<p>375.070 55199355</p> 	<p>AAS 728.670 77365317</p> 	<p>a) 030.793 Dirko HT</p> <p>b) 587.100 7734022 M 22x1,5x13</p>	<p>K:← 440.710 40004200 A/BS RD FPM 23x35x7 →Mot. 2935742</p> <hr/> <p>Panda (169) →Mot. 2939660</p> <p>K:← 069.540 46404094 AW/BS RD FPM 27x37x7 Mot. 2935743→</p> <hr/> <p>Panda (169) Mot. 2939661→</p> <p>K:→ 069.600 71754491 AW/BS LD FPM 74x88x8</p> <p>N:← 505.838 60809849 ASW RD FPM 30x42x7 →Mot. 2935742</p> <hr/> <p>Panda (169) →Mot. 2939660</p> <p>N:← 688.580 55189997 AW/BS RD FPM 31x55x7 Mot. 2935743→</p> <hr/> <p>Panda (169) Mot. 2939661→</p>	



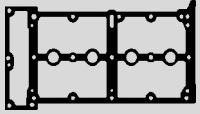





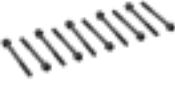
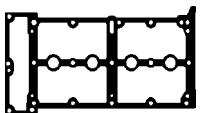





<p>FIAT</p> 				
<p>178 D6.011 188 A5.000</p> <p>4 Cyl. 1242 ccm Cyl. 70,8 Ø</p> <p>Brava 10/2000 → 10/2001</p> <p>Bravo 10/2000 → 10/2001</p> <p>Idea 01/2004 →</p> <p>Palio 03/2000 → 01/2012</p> <p>Punto 09/1999 → 04/2006</p> <p>Siena 06/2001 → 12/2009</p> <p>Stilo 02/2002 → 11/2006</p>	<p>S⊕* 180.390 71716871 →Mot. 616936</p> <p>ES⊕ 180.400 71716870 →Mot. 616936</p> <p>ES⊕ 505.270 71736243 Mot. 616937→ →Mot. 985541</p> <p>ES⊕ 505.590 71747636 Mot. 985541→</p> <p>CS* 309.990</p>	<p>180.270 46434596 1,65 mm ± 71,4 Ø</p> <p>→Mot. 616936</p> <p>104.316 46541740 Mot. 616937→ →Mot. 985541</p> <p>344.661 55202800 0,49 mm ± 72,4 Ø</p> <p>Mot. 985541→</p>	<p>ZKS 111.590 7795992 (10x) M 9x1,25x87</p> 	<p>199.010 55194045</p> 
<p>199 A4.000</p> <p>4 Cyl. 1242 ccm Cyl. 70,8 Ø</p> <p>Grande Punto 10/2005 →</p> <p>Punto Evo 10/2009 → 02/2012</p>	<p>ES⊕ 724.330 71741374</p> <p>CS* 431.560 71736317</p>	<p>040.554 55183371 0,49 mm ± 72,4 Ø</p> 	<p>ZKS 760.720 7696197 (10x) M 9x1,25x96</p> 	<p>ZKHS 724.280</p>  <p>505.060 71740678</p> 
<p>223 A3.011</p> <p>4 Cyl. 1242 ccm Cyl. 70,8 Ø</p> <p>Doblo 11/2001 →</p>	<p>CS* 309.990</p>	<p>104.316 46541740</p> 	<p>ZKS 111.590 7795992 (10x) M 9x1,25x87</p> 	<p>199.010 55194045</p> 
<p>223 A5.000</p> <p>4 Cyl. 1242 ccm Cyl. 70,8 Ø</p> <p>Doblo 03/2001 →</p>	<p>S⊕* 180.250 71715869 +7688450 →08/2003</p> <p>ES⊕ 180.260 71716868 +7688450 →08/2003</p> <p>ES⊕ 505.730 Mot. 2533528→</p> <p>ES⊕ 431.470 09/2003→ →Mot. 2533527</p> <p>CS* 431.560 71736317</p>	<p>710.280 46434102 →08/2003</p>  <p>040.554 55183371 0,49 mm ± 72,4 Ø</p> <p>09/2003→</p> 	<p>ZKS 760.720 7696197 (10x) M 9x1,25x96</p> 	<p>199.000 46759989 →06/2002</p>  <p>399.570 73502863 07/2002→</p> 



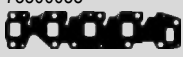
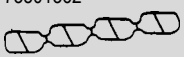



			<p>a) </p> <p>b) </p>	<p>K: </p> <p>N: </p>	
<p>069.630 46470334 FPM 16x</p>	<p>339.260 46526271</p> 	<p>AAS 375.490 71729223</p> 	<p>a) 030.793 Dirko HT</p> <p>b) 587.100 7734022 M 22x1,5x13</p>	<p>K:← 069.540 46404094 AW/BS RD FPM 27x37x7</p> <p>K:→ 375.320 46539824 SP LD FPM 74</p> <p>N:← 290.710 55195339 AW/BS RD FPM 40x55x7</p>	
<p>VAS 688.050 FPM</p> <p>476.691 55190344 FPM 8x</p>	<p>375.070 55199355</p> 	<p>AAS 444.760 77363787</p> 	<p>a) 030.793 Dirko HT</p> <p>b) 587.100 7734022 M 22x1,5x13</p>	<p>K:← 069.540 46404094 AW/BS RD FPM 27x37x7</p> <p>K:→ 069.600 71754491 AW/BS LD FPM 74x88x8</p> <p>N:← 688.580 55189997 AW/BS RD FPM 31x55x7</p>	
<p>069.630 46470334 FPM 16x</p>	<p>339.260 46526271</p> 		<p>a) 030.793 Dirko HT</p> <p>b) 587.100 7734022 M 22x1,5x13</p>	<p>K:← 069.540 46404094 AW/BS RD FPM 27x37x7</p> <p>K:→ 375.320 46539824 SP LD FPM 74</p> <p>N:← 290.710 55195339 AW/BS RD FPM 40x55x7</p>	
<p>VAS 825.042 FPM →Mot. 2533527</p> <p>VAS 688.050 FPM Mot. 2533528→</p> <p>701.289 46436047 FPM →Mot. 2533527 8x</p> <p>476.691 55190344 FPM Mot. 2533528→ 8x</p>	<p>375.070 55199355</p> 	<p>AAS 728.670 77365317</p> 	<p>a) 030.793 Dirko HT</p> <p>b) 587.100 7734022 M 22x1,5x13</p>	<p>K:← 440.710 40004200 A/BS RD FPM 23x35x7</p> <p>K:→ 069.600 71754491 AW/BS LD FPM 74x88x8</p> <p>N:← 505.838 60809849 ASW RD FPM 30x42x7</p>	



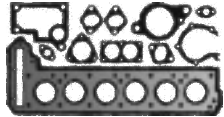
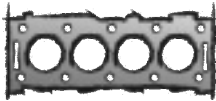

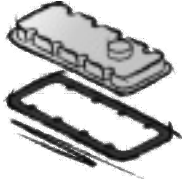

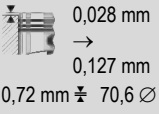
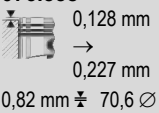
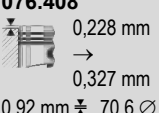
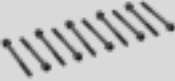
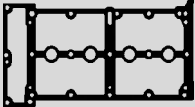

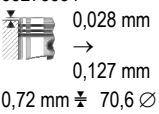
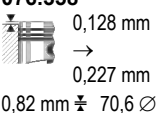
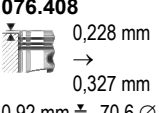
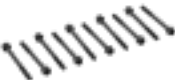
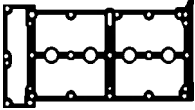





<p>FIAT</p> 				
<p>169 A1.000</p> <p>4 Cyl. 1248 ccm Cyl. 69,6 Ø</p> <p>500 Multijet 10/2007 →</p> <p>Panda Multijet 01/2006 →</p>	<p>ES⊕ 431.401 71729499</p>  <p>CS* 452.150 71736913</p>	<p>076.348 55278854</p>  <p>0,028 mm → 0,127 mm</p> <p>0,72 mm $\frac{1}{2}$ 70,6 Ø</p> <p>076.358</p>  <p>0,128 mm → 0,227 mm</p> <p>0,82 mm $\frac{1}{2}$ 70,6 Ø 1 ⊗</p> <p>076.408</p>  <p>0,228 mm → 0,327 mm</p> <p>0,92 mm $\frac{1}{2}$ 70,6 Ø 2 ⊗</p>	<p>ZKS 374.240 55192265 (10x) M 10x1,25x119</p> 	<p>074.173 73500063</p> 
<p>169 A5.000 199 B2.000</p> <p>4 Cyl. 1248 ccm Cyl. 69,6 Ø</p> <p>Grande Punto Multijet 07/2008 →</p> <p>Panda Multijet 06/2006 → 08/2013</p> <p>Punto Evo Multijet 07/2008 → 02/2012</p>	<p>ES⊕ 431.401 71729499</p>  <p>CS* 452.150 71736913</p>	<p>076.348 55278854</p>  <p>0,028 mm → 0,127 mm</p> <p>0,72 mm $\frac{1}{2}$ 70,6 Ø</p> <p>076.358</p>  <p>0,128 mm → 0,227 mm</p> <p>0,82 mm $\frac{1}{2}$ 70,6 Ø 1 ⊗</p> <p>076.408</p>  <p>0,228 mm → 0,327 mm</p> <p>0,92 mm $\frac{1}{2}$ 70,6 Ø 2 ⊗</p>	<p>ZKS 374.240 55192265 (10x) M 10x1,25x119</p> 	<p>074.173 73500063</p> 
<p>188 A8.000 188 A9.000</p> <p>4 Cyl. 1248 ccm Cyl. 69,6 Ø</p> <p>Doblo JTD 05/2004 → 12/2006</p> <p>Idea Multijet 01/2004 →</p> <p>Palio JTD 06/2003 → 01/2012</p> <p>Palio Multijet 03/2008 → 11/2011</p> <p>Panda Multijet 09/2003 →</p> <p>Punto JTD 06/2003 → 03/2012</p> <p>Siena JTD 09/2003 → 12/2009</p>	<p>ES⊕ 431.401 71729499</p>  <p>CS* 452.150 71736913</p>	<p>076.348 55278854</p>  <p>0,028 mm → 0,127 mm</p> <p>0,72 mm $\frac{1}{2}$ 70,6 Ø</p> <p>076.358</p>  <p>0,128 mm → 0,227 mm</p> <p>0,82 mm $\frac{1}{2}$ 70,6 Ø 1 ⊗</p> <p>076.408</p>  <p>0,228 mm → 0,327 mm</p> <p>0,92 mm $\frac{1}{2}$ 70,6 Ø 2 ⊗</p>	<p>ZKS 374.240 55192265 (10x) M 10x1,25x119</p> 	<p>074.173 73500063</p> 











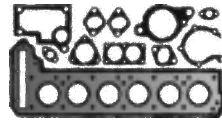
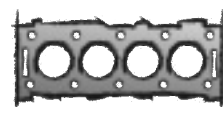

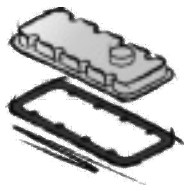

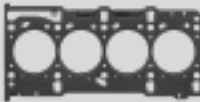
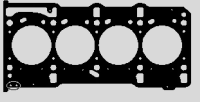

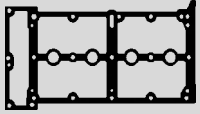
			<p>a) </p> <p>b) </p>	<p>K: </p> <p>N: </p>	
<p>VAS 445.100 46556651 FPM</p>	<p>431.310 73500058</p> 	<p>431.180 73501362</p> 	<p>a) 030.793 Dirko HT</p> <p>b) 587.100 7734022 M 22x1,5x13</p>	<p>K:← 445.060 55186757 AW/BS RD FPM 40x52x7</p> <p>K:→ 428.970 55180937 ASW LD PTFE/ACM 78x100x9</p>	<p>TLS 715.310</p>  <p>TLS 715.320</p> 
<p>VAS 445.100 46556651 FPM</p>	<p>431.310 73500058</p> 	<p>431.180 73501362</p> 	<p>a) 030.793 Dirko HT</p> <p>b) 587.100 7734022 M 22x1,5x13</p>	<p>K:← 445.060 55186757 AW/BS RD FPM 40x52x7</p> <p>K:→ 428.970 55180937 ASW LD PTFE/ACM 78x100x9</p>	<p>TLS 715.320</p> 
<p>VAS 445.100 46556651 FPM</p>	<p>431.310 73500058</p> 	<p>431.180 73501362</p> 	<p>a) 030.793 Dirko HT</p> <p>b) 587.100 7734022 M 22x1,5x13</p>	<p>K:← 445.060 55186757 AW/BS RD FPM 40x52x7</p> <p>K:→ 428.970 55180937 ASW LD PTFE/ACM 78x100x9</p>	<p>TLS 715.310</p> 



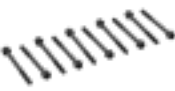
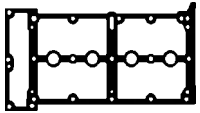





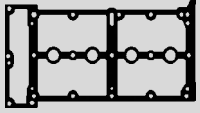





<p>FIAT</p> 				
<p>199 A2.000</p> <p>4 Cyl. 1248 ccm Cyl. 69,6 Ø</p> <p>Avventura JTD 10/2014 → 12/2019</p> <p>Doblo JTD 05/2005 →</p> <p>Doblo Multijet 10/2005 → 01/2010</p> <p>Fiorino Multijet 11/2007 →</p> <p>Grande Punto Multijet 10/2005 →</p> <p>Punto Evo Multijet 03/2009 →</p> <p>Punto Multijet 04/2008 →</p> <p>Qubo Multijet 02/2008 →</p>	<p>ES⊕ 431.401 71729499</p>  <p>CS* 397.470 71753767</p> <p>CS* 452.150 71736913</p>	<p>076.348 55278854</p>  <p>0,028 mm → 0,127 mm</p> <p>0,72 mm $\frac{1}{4}$ 70,6 Ø</p> <p>076.358</p>  <p>0,128 mm → 0,227 mm</p> <p>0,82 mm $\frac{1}{4}$ 70,6 Ø 1 ⊗</p> <p>076.408</p>  <p>0,228 mm → 0,327 mm</p> <p>0,92 mm $\frac{1}{4}$ 70,6 Ø 2 ⊗</p>	<p>ZKS 374.240 55192265 (10x) M 10x1,25x119</p> 	<p>074.173 73500063</p> 
<p>199 A3.000</p> <p>4 Cyl. 1248 ccm Cyl. 69,6 Ø</p> <p>Doblo Multijet 02/2010 →</p> <p>Grande Punto Multijet 10/2005 → 12/2010</p> <p>Idea Multijet 04/2005 →</p> <p>Linea Multijet 10/2006 →</p> <p>Punto Evo Multijet 03/2009 →</p>	<p>ES⊕ 655.321 →11/2006</p>  <p>ES⊕ 789.900 11/2006→</p>  <p>CS* 452.150 71736913</p>	<p>076.348 55278854</p>  <p>0,028 mm → 0,127 mm</p> <p>0,72 mm $\frac{1}{4}$ 70,6 Ø</p> <p>076.358</p>  <p>0,128 mm → 0,227 mm</p> <p>0,82 mm $\frac{1}{4}$ 70,6 Ø 1 ⊗</p> <p>076.408</p>  <p>0,228 mm → 0,327 mm</p> <p>0,92 mm $\frac{1}{4}$ 70,6 Ø 2 ⊗</p>	<p>ZKS 374.240 55192265 (10x) M 10x1,25x119</p> 	<p>074.173 73500063</p> 









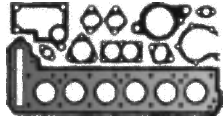
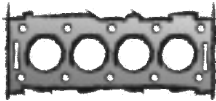

			<p>a) </p> <p>b) </p>	<p>K: </p> <p>N: </p>	
<p>VAS 445.100 46556651 FPM</p>	<p>431.310 73500058</p> 	<p>431.180 73501362</p> 	<p>a) 030.793 Dirko HT</p> <p>b) 587.100 7734022 M 22x1,5x13</p>	<p>K:← 445.060 55186757 AW/BS RD FPM 40x52x7</p> <p>K:→ 428.970 55180937 ASW LD PTFE/ACM 78x100x9</p>	<p>TLS 715.310</p>  <p>TLS 715.320</p> 
<p>VAS 445.100 46556651 FPM</p>	<p>431.310 73500058</p> 	<p>577.260 55198271 →11/2006</p> <p>718.200 71749369 4x 11/2006→</p> 	<p>a) 030.793 Dirko HT</p> <p>b) 274.410 46823509 M 14x1,5x13,5</p> <p>b) 587.100 7734022 M 22x1,5x13</p>	<p>K:← 445.060 55186757 AW/BS RD FPM 40x52x7</p> <p>K:→ 428.970 55180937 ASW LD PTFE/ACM 78x100x9</p>	<p>TLS 716.760</p> 

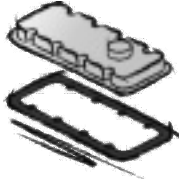

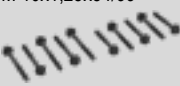







<p>FIAT</p> 				
<p>199 B1.000 199 B4.000 199 B8.000</p> <p>4 Cyl. 1248 ccm Cyl. 69,6 Ø</p> <p>500 L Multijet 09/2012 →</p> <p>500 Multijet 09/2009 →</p> <p>Fiorino Multijet 07/2009 →</p> <p>Grande Punto Multijet 04/2010 →</p> <p>Idea Multijet 05/2008 → 12/2012</p> <p>Linea Multijet 09/2009 →</p> <p>Panda Multijet 04/2015 →</p> <p>Punto Evo Multijet 03/2009 → 02/2012</p> <p>Punto Multijet 03/2009 →</p> <p>Qubo Multijet 07/2010 →</p> <p>Strada Multijet 03/2010 →</p> <p>Tipo 10/2015 →</p>	<p>ES⊕ 789.900 </p> <p>CS* 397.470 71753767</p>	<p>076.348 55278854  0,028 mm → 0,127 mm 0,72 mm $\frac{1}{2}$ 70,6 Ø</p> <p>076.358  0,128 mm → 0,227 mm 0,82 mm $\frac{1}{2}$ 70,6 Ø 1 ⊗</p> <p>076.408  0,228 mm → 0,327 mm 0,92 mm $\frac{1}{2}$ 70,6 Ø 2 ⊗</p>	<p>ZKS 374.240 55192265 (10x) M 10x1,25x119 </p>	<p>074.173 73500063 </p>
<p>223 A9.000</p> <p>4 Cyl. 1248 ccm Cyl. 69,6 Ø</p> <p>Doblo Multijet 10/2005 →</p> <p>Grande Punto Multijet 04/2010 →</p> <p>Punto Evo Multijet 10/2009 → 02/2012</p> <p>Strada Multijet 05/2006 →</p>	<p>ES⊕ 655.321 →11/2006 </p> <p>ES⊕ 789.900 11/2006→ </p> <p>CS* 397.470 71753767 Punto Evo (199) G. Punto 199</p> <p>CS* 452.150 71736913 Strada (178) Doblo (119/223)</p>	<p>076.348 55278854  0,028 mm → 0,127 mm 0,72 mm $\frac{1}{2}$ 70,6 Ø</p> <p>076.358  0,128 mm → 0,227 mm 0,82 mm $\frac{1}{2}$ 70,6 Ø 1 ⊗</p> <p>076.408  0,228 mm → 0,327 mm 0,92 mm $\frac{1}{2}$ 70,6 Ø 2 ⊗</p>	<p>ZKS 374.240 55192265 (10x) M 10x1,25x119 </p>	<p>074.173 73500063 </p>











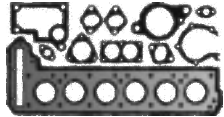
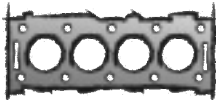

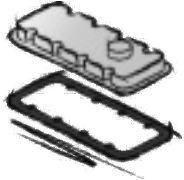
			<p>a) </p> <p>b) </p>	<p>K: </p> <p>N: </p>	
<p>VAS 445.100 46556651 FPM</p>	<p>431.310 73500058</p> 	<p>718.200 71749369 4x</p> 	<p>a) 030.793 Dirko HT</p> <p>b) 274.410 46823509 M 14x1,5x13,5</p>	<p>K:← 445.060 55186757 AW/BS RD FPM 40x52x7</p> <p>K:→ 428.970 55180937 ASW LD PTFE/ACM 78x100x9</p>	<p>TLS 007.810</p> 
<p>VAS 445.100 46556651 FPM</p>	<p>431.310 73500058</p> 	<p>577.260 55198271 →11/2006</p> <p>718.200 71749369 4x 11/2006→</p> 	<p>a) 030.793 Dirko HT</p> <p>b) 587.100 7734022 M 22x1,5x13</p>	<p>K:← 445.060 55186757 AW/BS RD FPM 40x52x7</p> <p>K:→ 428.970 55180937 ASW LD PTFE/ACM 78x100x9</p>	<p>TLS 007.810 G. Punto 199 Punto Evo (199)</p>  <p>TLS 716.760 Strada (178) Doblo (119/223)</p> 





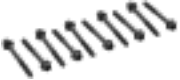

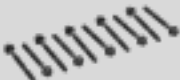

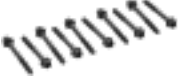
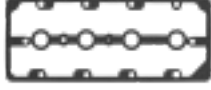







<p>FIAT</p> 				
<p>199 A1.000 199 A9.000 263 A2.000 263 A6.000</p> <p>4 Cyl. 1248 ccm Cyl. 69,6 Ø</p> <p>Doblo Multijet 02/2010 → Fiorino Multijet 11/2007 → Panda Multijet 02/2012 → Punto Evo Multijet 03/2009 → Punto Multijet 04/2008 → Qubo Multijet 02/2008 →</p>	<p>ES⊕ 789.900</p>  <p>CS* 397.470 71753767</p>	<p>076.348 55278854</p>  <p>0,028 mm → 0,127 mm</p> <p>0,72 mm $\frac{1}{2}$ 70,6 Ø</p> <p>076.358</p>  <p>0,128 mm → 0,227 mm</p> <p>0,82 mm $\frac{1}{2}$ 70,6 Ø 1 ⊗</p> <p>076.408</p>  <p>0,228 mm → 0,327 mm</p> <p>0,92 mm $\frac{1}{2}$ 70,6 Ø 2 ⊗</p>	<p>ZKS 374.240 55192265 (10x) M 10x1,25x119</p> 	<p>074.173 73500063</p> 
<p>312 A8.000 312 B1.000</p> <p>4 Cyl. 1248 ccm Cyl. 69,6 Ø</p> <p>500 Multijet 09/2009 → Panda Multijet 06/2014 →</p>	<p>ES⊕ 705.100</p>  <p>CS* 705.140 Euro 6</p>	<p>076.348 55278854</p>  <p>0,028 mm → 0,127 mm</p> <p>0,72 mm $\frac{1}{2}$ 70,6 Ø</p> <p>076.358</p>  <p>0,128 mm → 0,227 mm</p> <p>0,82 mm $\frac{1}{2}$ 70,6 Ø 1 ⊗</p> <p>076.408</p>  <p>0,228 mm → 0,327 mm</p> <p>0,92 mm $\frac{1}{2}$ 70,6 Ø 2 ⊗</p>	<p>ZKS 374.240 55192265 (10x) M 10x1,25x119</p> 	<p>074.173 73500063</p> 
<p>225 A2.000 312 B2.000 312 B5.000 330 A1.000 552 66 963 552 83 775 955 B2.000</p> <p>4 Cyl. 1248 ccm Cyl. 69,6 Ø</p> <p>500 L Multijet 06/2014 → 500 Multijet 06/2016 → 500X Multijet 11/2014 → Doblo Multijet 03/2016 → Fiorino Multijet 07/2009 → Panda Multijet 06/2014 → Punto Multijet 03/2012 → Qubo Multijet 07/2010 → Tipo 10/2015 →</p>	<p>ES⊕ 705.100</p>  <p>CS* 705.140 Euro 6</p>	<p>076.348 55278854</p>  <p>0,028 mm → 0,127 mm</p> <p>0,72 mm $\frac{1}{2}$ 70,6 Ø</p> <p>076.358</p>  <p>0,128 mm → 0,227 mm</p> <p>0,82 mm $\frac{1}{2}$ 70,6 Ø 1 ⊗</p> <p>076.408</p>  <p>0,228 mm → 0,327 mm</p> <p>0,92 mm $\frac{1}{2}$ 70,6 Ø 2 ⊗</p>	<p>ZKS 374.240 55192265 (10x) M 10x1,25x119</p> 	<p>074.173 73500063</p> 











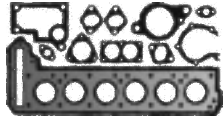
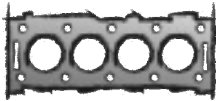

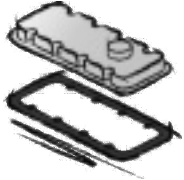
			<p>a) </p> <p>b) </p>	<p>K: </p> <p>N: </p>	
<p>VAS 445.100 46556651 FPM</p>	<p>431.310 73500058 </p>	<p>718.200 71749369 4x </p>	<p>a) 030.793 Dirko HT</p> <p>b) 587.100 7734022 M 22x1,5x13</p>	<p>K:← 445.060 55186757 AW/BS RD FPM 40x52x7</p> <p>K:→ 428.970 55180937 ASW LD PTFE/ACM 78x100x9</p>	<p>TLS 007.810 </p>
<p>VAS 445.100 46556651 FPM</p>	<p>431.310 73500058 </p>	<p>718.200 71749369 4x </p>	<p>a) 030.793 Dirko HT</p> <p>b) 274.410 46823509 M 14x1,5x13,5</p> <p>b) 587.100 7734022 M 22x1,5x13</p>	<p>K:← 445.060 55186757 AW/BS RD FPM 40x52x7</p> <p>K:→ 428.970 55180937 ASW LD PTFE/ACM 78x100x9</p>	<p>TLS 705.300</p>
<p>VAS 445.100 46556651 FPM</p>	<p>431.310 73500058 </p>	<p>718.200 71749369 4x </p>	<p>a) 030.793 Dirko HT</p> <p>b) 274.410 46823509 M 14x1,5x13,5</p>	<p>K:← 445.060 55186757 AW/BS RD FPM 40x52x7</p> <p>K:→ 428.970 55180937 ASW LD PTFE/ACM 78x100x9</p>	<p>TLS 705.300</p>

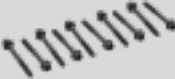
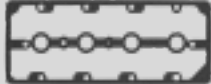

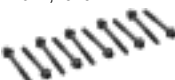
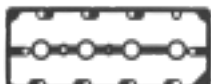

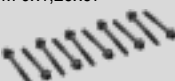
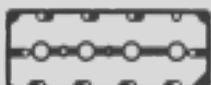

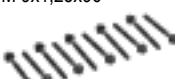
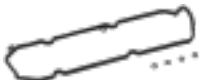

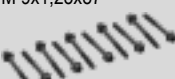
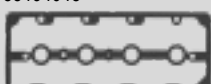











<p>FIAT</p> 				
<p>146 A2.000/146/246</p> <p>4 Cyl. 1301 ccm Cyl. 80,5 Ø</p> <p>Uno Turbo 04/1985 → 03/1991</p>		<p>144.340 7640074 1,65 mm $\frac{3}{4}$ 81,5 Ø Mot. 6510791→</p> 	<p>ZKS 760.870 46430687 (5x) +46430688 (5x) M 10x1,25x84/99</p> 	<p>237.833 4448677 ↑  435.361 7784728 ↓ </p>
<p>146 A5.000</p> <p>4 Cyl. 1301 ccm Cyl. 76,0 Ø</p> <p>Duna 01/1987 → 12/1991</p> <p>Elba 04/1991 → 02/1995</p> <p>Fiorino 12/1987 → 12/1994</p> <p>Penny 01/1986 → 12/1990</p>		<p>399.630 46541379 1,90 mm $\frac{3}{4}$ 77 Ø</p> 		
<p>127 A5.000 146 B1.000 156 A5.000</p> <p>4 Cyl. 1301 ccm Cyl. 76,1 Ø</p> <p>127 04/1981 → 05/1996</p> <p>147 10/1980 → 10/1995</p> <p>Duna 05/1988 → 04/1992</p> <p>Fiorino 01/1982 → 12/1988</p> <p>Fiorino Multijet 03/1989 → 08/1997</p> <p>Panda 04/1986 → 12/1992</p> <p>Penny 04/1986 → 12/1988</p> <p>Uno 06/1983 → 03/1992</p>		<p>986.283 7788641</p>  <p>0,860 mm → 1,050 mm</p> <p>1,92 mm $\frac{3}{4}$ 1 Ø</p> 		
<p>552 68 176</p> <p>4 Cyl. 1332 ccm Cyl. 70,0 Ø</p> <p>Argo 03/2017 →</p> <p>Cronos 12/2017 →</p> <p>Pulse 10/2021 →</p> <p>Strada 06/2020 →</p> <p>Uno 09/2016 →</p>	<p>ES 889.680</p>	<p>360.140 55268170 0,72 mm $\frac{3}{4}$ 71 Ø</p>		<p>531.050 7090246</p>











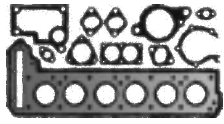
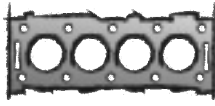

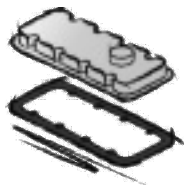
			<p>a) </p> <p>b) </p>	<p>K: </p> <p>N: </p>	
<p>VAS 294.250 FPM 294.110 7553637 FPM 8x</p>			<p>a) 191.965 4179038</p>  <p>b) 587.100 7734022 M 22x1,5x13</p>	<p>K:← 440.760 40004950 AW/B RD FPM 40x56x7</p> <p>K:→ 440.780 40004280 AW/BS LD ACM 64x80x8</p> <p>N:← 440.750 40004940 AW/BS RD FPM 30x52x7</p>	
<p>VAS 702.706 FPM 553.190 5930415 FPM 8x</p>			<p>b) 587.100 7734022 M 22x1,5x13</p>	<p>K:← 440.760 40004950 AW/B RD FPM 40x56x7</p> <p>N:← 440.750 40004940 AW/BS RD FPM 30x52x7</p>	
<p>VAS 294.250 FPM 294.110 7553637 FPM 8x</p>			<p>b) 587.100 7734022 M 22x1,5x13</p>	<p>K:← 440.760 40004950 AW/B RD FPM 40x56x7</p> <p>N:← 440.750 40004940 AW/BS RD FPM 30x52x7</p>	
	<p>574.770 52109530</p> 	<p>535.330 7090209 4x</p> 	<p>a) 036.164 Dirko HT / EU</p> <p>a) 510.031 Dirko HT / USA/CDN/MEX</p> <p>a) 527.291 Dirko HT / RU</p> <p>a) 648.661 Dirko HT / BR</p> <p>b) 298.480 M 14x1,5x18</p>	<p>K:← 331.530 7091279 ASW RD FPM 34x47x5,5</p> <p>K:→ 247.290 55267742 AS LD FPM 80x96x8</p>	

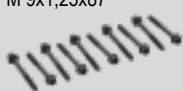
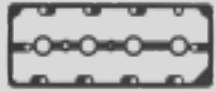

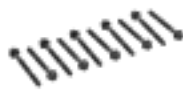



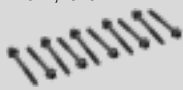
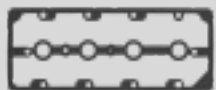





<p>FIAT</p> 				
<p>KFT KFV</p> <p>4 Cyl. 1360 ccm Cyl. 75,0 Ø</p> <p>Fiorino 11/2007 →</p> <p>Qubo 02/2008 →</p>	<p>S⊕* 867.540 </p> <p>CS* 399.840 ZLBS 449.740 78,5 mm Ø</p>	<p>984.136 9677399780 1,27 mm $\frac{1}{2}$ 76 Ø </p> <p>117.831 1,47 mm $\frac{1}{2}$ 76 Ø </p>	<p>ZKS 758.300 9624951480 (10x) M 10x1,5x175</p> 	<p>776.416 9400249549</p> 
<p>169 A3.000</p> <p>4 Cyl. 1368 ccm Cyl. 72,0 Ø</p> <p>500 10/2007 →</p> <p>Panda 10/2006 →</p>	<p>ES⊕ 431.590 71738337</p> <p>CS* 309.990</p>	<p>344.661 55202800 0,49 mm $\frac{1}{2}$ 72,4 Ø </p>	<p>ZKS 111.590 7795992 (10x) M 9x1,25x87</p> 	<p>199.010 55194045</p> 
<p>178 F3.011</p> <p>4 Cyl. 1368 ccm Cyl. 72,0 Ø</p> <p>Idea 09/2005 →</p> <p>Palio 04/2005 →</p> <p>Siena 06/2004 → 10/2013</p> <p>Strada 06/2005 →</p>	<p>CS* 309.990</p>	<p>104.604 55190882 72 Ø</p>	<p>ZKS 760.720 7696197 (10x) M 9x1,25x96</p> 	<p>807.890 46748519</p>
<p>192 B2.000</p> <p>4 Cyl. 1368 ccm Cyl. 72,0 Ø</p> <p>Bravo 04/2007 → 12/2014</p> <p>Idea 12/2003 →</p> <p>Stilo 03/2005 → 08/2008</p>	<p>ES⊕ 431.590 71738337 05/2006→</p> <p>CS* 309.990</p>	<p>344.661 55202800 0,49 mm $\frac{1}{2}$ 72,4 Ø </p> <p>05/2006→</p>	<p>ZKS 111.590 7795992 (10x) M 9x1,25x87</p> 	<p>199.010 55194045</p> 











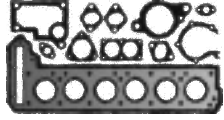
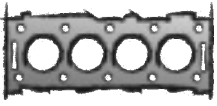

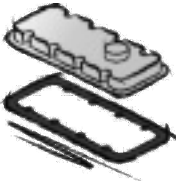
			<p>a) </p> <p>b) </p>	<p>K: </p> <p>N: </p>	
<p>VAS 825.042 FPM 701.289 46436047 FPM 8x</p>	<p>258.311 9652981380 </p>	<p>258.620 9567498080 4x </p>	<p>a) 984.451 </p> <p>b) 434.941 M 16x1,5x12 incl. 813.052</p> <p>b) 834.823 9400164889 NBR A 16,7x24x1,5 FE/NBR</p>	<p>K:← 369.530 9653526680 ASW RD PTFE/ACM 42x66x7</p> <p>K:← 505.740 ASW RD FPM/ACM 42x66x6</p> <p>K:→ 135.110 55229956 ASW LD FPM/ACM 85x105x9</p> <p>K:→ 315.494 ASW LD FPM/ACM 85x105x12</p> <p>K:→ 369.470 9653528580 ASW LD PTFE/ACM 85x105x8</p> <p>N:← 505.366 9653528780 9400236499 ASW RD FPM/ACM 36x50x7</p>	
<p>069.630 46470334 FPM 16x</p>	<p>339.260 46526271 </p>	<p>AAS 689.940 71739944 </p>	<p>a) 030.793 Dirko HT</p> <p>b) 878.110 incl. 110.604 55184773 M 12x1,25x13</p> <p>b) 110.604 10261060 CU A 12x16x1,5</p>	<p>K:← 069.540 46404094 AW/BS RD FPM 27x37x7</p> <p>K:→ 375.320 46539824 SP LD FPM 74</p> <p>N:← 290.710 55195339 AW/BS RD FPM 40x55x7</p>	
<p>VAS 688.050 FPM 476.691 55190344 FPM 8x</p>	<p>375.070 55199355 </p>		<p>a) 030.793 Dirko HT</p> <p>b) 587.100 7734022 M 22x1,5x13</p>	<p>K:← 069.540 46404094 AW/BS RD FPM 27x37x7</p> <p>K:→ 375.320 46539824 SP LD FPM 74</p> <p>N:← 505.838 60809849 ASW RD FPM 30x42x7</p>	
<p>069.630 46470334 FPM 16x</p>	<p>339.260 46526271 </p>	<p>AAS 689.940 71739944 </p>	<p>a) 030.793 Dirko HT</p> <p>b) 878.110 incl. 110.604 55184773 M 12x1,25x13</p> <p>b) 110.604 10261060 CU A 12x16x1,5</p>	<p>K:← 069.540 46404094 AW/BS RD FPM 27x37x7</p> <p>K:→ 375.320 46539824 SP LD FPM 74</p> <p>N:← 290.710 55195339 AW/BS RD FPM 40x55x7</p>	

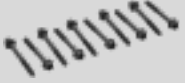
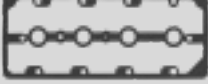

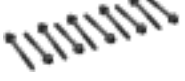
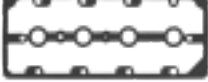

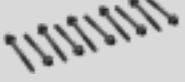
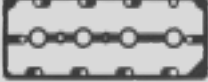

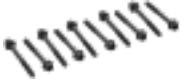









<p>FIAT</p> 				
<p>198 A1.000 198 A4.000</p> <p>4 Cyl. 1368 ccm Cyl. 72,0 Ø</p> <p>Avventura 01/2016 → 12/2019</p> <p>Bravo 09/2007 → 12/2016</p> <p>Doblo 02/2010 →</p> <p>Grande Punto 09/2007 →</p> <p>Linea 05/2007 →</p> <p>Punto 02/2009 →</p>	<p>ES⊕ 334.690 71749165 +55195339</p>  <p>CS* 309.990</p>	<p>344.671 55206232 0,72 mm $\frac{\pm}{\pm}$ 72,4 Ø</p> 	<p>ZKS 111.590 7795992 (10x) M 9x1,25x87</p> 	<p>199.010 55194045</p> 
<p>198 A7.000</p> <p>4 Cyl. 1368 ccm Cyl. 72,0 Ø</p> <p>Bravo 04/2010 → 12/2014</p>	<p>CS 928.760</p>	<p>344.671 55206232 0,72 mm $\frac{\pm}{\pm}$ 72,4 Ø</p> 	<p>ZKS 111.590 7795992 (10x) M 9x1,25x87</p> 	<p>199.010 55194045</p> 
<p>199 A6.000</p> <p>4 Cyl. 1368 ccm Cyl. 72,0 Ø</p> <p>Grande Punto 10/2005 → 08/2011</p> <p>Punto 11/2005 → 03/2012</p>	<p>ES⊕ 735.230 74745446 05/2006→</p> <p>CS* 309.990</p>	<p>344.661 55202800 0,49 mm $\frac{\pm}{\pm}$ 72,4 Ø</p> 	<p>ZKS 111.590 7795992 (10x) M 9x1,25x87</p> 	<p>199.010 55194045</p> 
<p>199 A7.000</p> <p>4 Cyl. 1368 ccm Cyl. 72,0 Ø</p> <p>Grande Punto 10/2005 → 07/2007</p> <p>Punto 03/2012 →</p> <p>Punto Evo 07/2009 → 02/2012</p>	<p>ES⊕ 037.461</p> <p>CS* 431.560 71736317</p>	<p>040.554 55183371 0,49 mm $\frac{\pm}{\pm}$ 72,4 Ø</p> 	<p>ZKS 760.720 7696197 (10x) M 9x1,25x96</p> 	<p>ZKHS 724.280</p>  <p>505.060 71740678</p> 
<p>312 A1.000 312 A3.000</p> <p>4 Cyl. 1368 ccm Cyl. 72,0 Ø</p> <p>500 02/2013 →</p> <p>500L 09/2013 →</p>	<p>ES⊕ 928.770 Euro 5</p> <p>CS 928.760</p>	<p>344.671 55206232 0,72 mm $\frac{\pm}{\pm}$ 72,4 Ø</p>  <p>354.070 55265110 1,67 mm $\frac{\pm}{\pm}$ 72,4 Ø</p>	<p>ZKS 111.590 7795992 (10x) M 9x1,25x87</p> 	<p>199.010 55194045</p> 











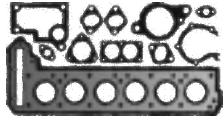
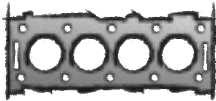

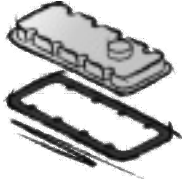

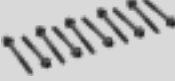

			<p>a) </p> <p>b) </p>	<p>K: </p> <p>N: </p>	
<p>069.630 46470334 FPM 16x</p>	<p>344.720 55210321</p> 	<p>AAS 334.670 77364551</p> 	<p>a) 030.793 Dirko HT</p> <p>b) 878.110 incl. 110.604 55184773 M 12x1,25x13</p> <p>b) 110.604 10261060 CU A 12x16x1,5</p>	<p>K:← 069.540 46404094 AW/BS RD FPM 27x37x7</p> <p>K:→ 375.320 46539824 SP LD FPM 74</p> <p>N:← 290.710 55195339 AW/BS RD FPM 40x55x7</p>	<p>TLS 796.230</p> 
<p>069.630 46470334 FPM 16x</p>	<p>514.192 55225376</p> 	<p>AAS 334.670 77364551</p> 	<p>a) 030.793 Dirko HT</p> <p>b) 878.110 incl. 110.604 55184773 M 12x1,25x13</p> <p>b) 110.604 10261060 CU A 12x16x1,5</p>	<p>K:← 069.540 46404094 AW/BS RD FPM 27x37x7</p> <p>K:→ 375.320 46539824 SP LD FPM 74</p> <p>N:← 290.710 55195339 AW/BS RD FPM 40x55x7</p>	<p>TLS 002.490</p>
<p>069.630 46470334 FPM 16x</p>	<p>339.260 46526271</p> 	<p>AAS 730.310 77364149</p> 	<p>a) 030.793 Dirko HT</p> <p>b) 878.110 incl. 110.604 55184773 M 12x1,25x13</p> <p>b) 110.604 10261060 CU A 12x16x1,5</p>	<p>K:← 069.540 46404094 AW/BS RD FPM 27x37x7</p> <p>K:→ 375.320 46539824 SP LD FPM 74</p> <p>N:← 290.710 55195339 AW/BS RD FPM 40x55x7</p>	
<p>VAS 688.050 FPM</p> <p>476.691 55190344 FPM 8x</p>	<p>375.070 55199355</p> 	<p>AAS 444.760 77363787</p> 	<p>a) 030.793 Dirko HT</p> <p>b) 587.100 7734022 M 22x1,5x13</p>	<p>K:← 069.540 46404094 AW/BS RD FPM 27x37x7</p> <p>K:→ 069.600 71754491 AW/BS LD FPM 74x88x8</p> <p>N:← 290.710 55195339 AW/BS RD FPM 40x55x7</p>	
<p>069.630 46470334 FPM 16x</p>	<p>514.161 55222260</p>  <p>514.192 55225376</p> 	<p>AAS 334.670 77364551</p> 	<p>a) 030.793 Dirko HT</p> <p>b) 878.110 incl. 110.604 55184773 M 12x1,25x13</p> <p>b) 110.604 10261060 CU A 12x16x1,5</p>	<p>K:← 069.540 46404094 AW/BS RD FPM 27x37x7</p> <p>K:→ 375.320 46539824 SP LD FPM 74</p> <p>N:← 290.710 55195339 AW/BS RD FPM 40x55x7</p>	<p>TLS 002.440 TLS 940.450</p>

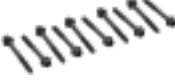



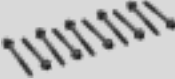
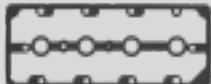

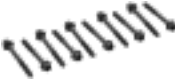
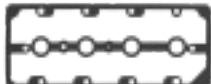







<p>FIAT</p> 				
<p>323 B6.600</p> <p>4 Cyl. 1368 ccm Cyl. 72,0 Ø</p> <p>Avventura 10/2014 → 07/2016</p> <p>Grande Punto 06/2009 → 07/2014</p> <p>Linea 09/2007 →</p> <p>Punto Evo 10/2014 →</p>		<p>344.661 55202800 0,49 mm $\frac{1}{16}$ 72,4 Ø</p> 	<p>ZKS 111.590 7795992 (10x) M 9x1,25x87</p> 	<p>199.010 55194045</p> 
<p>350 A1.000</p> <p>4 Cyl. 1368 ccm Cyl. 72,0 Ø</p> <p>Doblo 10/2005 →</p> <p>Fiorino 06/2008 →</p> <p>Grande Punto 06/2005 →</p> <p>Idea 10/2005 →</p> <p>Linea 06/2007 →</p> <p>Palio 10/2002 →</p> <p>Panda 10/2009 →</p> <p>Punto 03/2009 →</p> <p>Punto Evo 03/2009 → 02/2012</p> <p>Qubo 10/2009 →</p> <p>Siena 01/2007 → 12/2009</p>	<p>ES⊕ 037.461 ES⊕ 397.341 CNG CS* 431.560 71736317</p>	<p>040.554 55183371 0,49 mm $\frac{1}{16}$ 72,4 Ø</p> 	<p>ZKS 760.720 7696197 (10x) M 9x1,25x96</p> 	<p>ZKHS 724.280</p>  <p>505.060 71740678</p> 
<p>552 53 268</p> <p>4 Cyl. 1368 ccm Cyl. 72,0 Ø</p> <p>124 Spider 03/2016 →</p>	<p>CS 928.790</p>	<p>344.671 55206232 0,72 mm $\frac{1}{8}$ 72,4 Ø</p> 	<p>ZKS 111.590 7795992 (10x) M 9x1,25x87</p> 	<p>ZKHS 944.170</p> <p>199.010 55194045</p>  <p>944.000 55233643</p>  <p>939.400 55233644 4x</p>









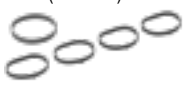

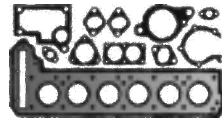
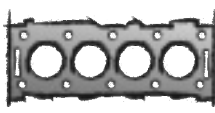

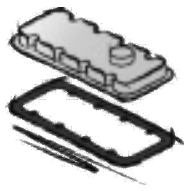
			<p>a) </p> <p>b) </p>	<p>K: </p> <p>N: </p>	
<p>069.630 46470334 FPM 16x</p>	<p>339.260 46526271</p> 		<p>a) 030.793 Dirko HT</p> <p>b) 878.110 incl. 110.604 55184773 M 12x1,25x13</p> <p>b) 110.604 10261060 CU A 12x16x1,5</p>	<p>K:← 069.540 46404094 AW/BS RD FPM 27x37x7</p> <p>K:→ 375.320 46539824 SP LD FPM 74</p> <p>N:← 290.710 55195339 AW/BS RD FPM 40x55x7</p>	
<p>VAS 688.050 FPM</p> <p>476.691 55190344 FPM 8x</p>	<p>375.070 55199355</p> 	<p>AAS 444.760 77363787</p>  <p>397.130 CNG 77365050</p> 	<p>a) 030.793 Dirko HT</p> <p>b) 587.100 7734022 M 22x1,5x13</p>	<p>K:← 069.540 46404094 AW/BS RD FPM 27x37x7</p> <p>K:→ 069.600 71754491 AW/BS LD FPM 74x88x8</p> <p>N:← 290.710 55195339 AW/BS RD FPM 40x55x7</p>	
<p>069.630 46470334 FPM 16x</p>	<p>718.411 55278507</p> 	<p>AAS 926.370 77366687</p>	<p>a) 030.793 Dirko HT</p> <p>b) 878.110 incl. 110.604 55184773 M 12x1,25x13</p> <p>b) 110.604 10261060 CU A 12x16x1,5</p>	<p>K:← 069.540 46404094 AW/BS RD FPM 27x37x7</p> <p>K:→ 375.320 46539824 SP LD FPM 74</p> <p>N:← 688.580 55189997 AW/BS RD FPM 31x55x7</p>	

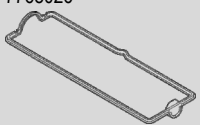

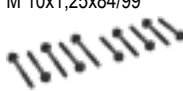
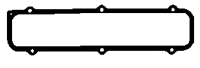

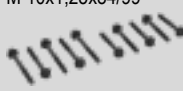
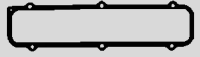

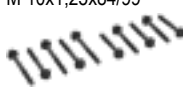
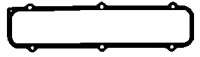







<p>FIAT</p> 				
<p>552 63 623/624</p> <p>4 Cyl. 1368 ccm Cyl. 72,0 Ø</p> <p>500X 09/2014 →</p>	<p>CS 928.790</p>	<p>344.671 55206232 0,72 mm $\frac{3}{4}$ 72,4 Ø</p> 	<p>ZKS 111.590 7795992 (10x) M 9x1,25x87</p> 	<p>ZKHS 944.170 199.010 55194045</p>  <p>944.000 55233643</p>  <p>939.400 55233644 4x</p>
<p>552 77 701</p> <p>4 Cyl. 1368 ccm Cyl. 72,0 Ø</p> <p>500X 03/2017 →</p>	<p>ES⊕ 928.770 Euro 5 CS 928.760</p>	<p>344.671 55206232 0,72 mm $\frac{3}{4}$ 72,4 Ø</p> 	<p>ZKS 111.590 7795992 (10x) M 9x1,25x87</p> 	<p>199.010 55194045</p> 
<p>843 A1.000</p> <p>4 Cyl. 1368 ccm Cyl. 72,0 Ø</p> <p>500 L 09/2012 →</p> <p>Doblo 02/2010 →</p> <p>Idea 01/2004 →</p> <p>Punto 09/2003 → 03/2012</p> <p>Stilo 10/2003 → 08/2008</p> <p>Tipo 10/2015 →</p>	<p>ES⊕ 431.590 71738337 05/2006→ CS* 309.990</p>	<p>344.661 55202800 0,49 mm $\frac{3}{4}$ 72,4 Ø</p> 	<p>ZKS 111.590 7795992 (10x) M 9x1,25x87</p> 	<p>199.010 55194045</p> 
<p>940 B7.000</p> <p>4 Cyl. 1368 ccm Cyl. 72,0 Ø</p> <p>500 L 10/2013 →</p> <p>Tipo 03/2016 →</p>	<p>ES⊕ 928.770 Euro 5</p>	<p>344.671 55206232 0,72 mm $\frac{3}{4}$ 72,4 Ø</p> 	<p>ZKS 111.590 7795992 (10x) M 9x1,25x87</p> 	<p>199.010 55194045</p> 











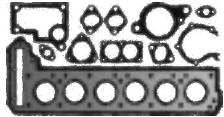
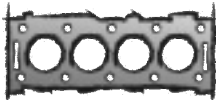

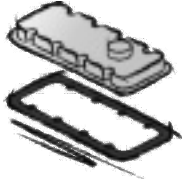



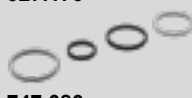
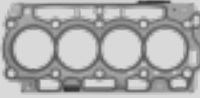
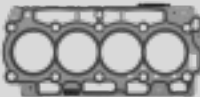
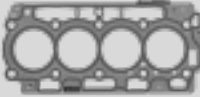

			<p>a) </p> <p>b) </p>	<p>K: </p> <p>N: </p>	
<p>069.630 46470334 FPM 16x</p>	<p>718.411 55278507</p> 	<p>AAS 926.370 77366687</p>	<p>a) 030.793 Dirko HT</p> <p>b) 878.110 incl. 110.604 55184773 M 12x1,25x13</p> <p>b) 110.604 10261060 CU A 12x16x1,5</p>	<p>K:← 069.540 46404094 AW/BS RD FPM 27x37x7</p> <p>K:→ 375.320 46539824 SP LD FPM 74</p> <p>N:← 688.580 55189997 AW/BS RD FPM 31x55x7</p>	<p>TLS 940.450</p>
<p>069.630 46470334 FPM 16x</p>	<p>514.161 55222260</p> 	<p>AAS 334.670 77364551</p> 	<p>a) 030.793 Dirko HT</p> <p>b) 878.110 incl. 110.604 55184773 M 12x1,25x13</p> <p>b) 110.604 10261060 CU A 12x16x1,5</p>	<p>K:← 069.540 46404094 AW/BS RD FPM 27x37x7</p> <p>N:← 290.710 55195339 AW/BS RD FPM 40x55x7</p>	<p>TLS 940.450</p>
<p>069.630 46470334 FPM 16x</p>	<p>339.260 46526271</p> 	<p>AAS 689.940 71739944</p> 	<p>a) 030.793 Dirko HT</p> <p>b) 587.100 7734022 M 22x1,5x13</p> <p>b) 878.110 incl. 110.604 55184773 M 12x1,25x13</p> <p>b) 110.604 10261060 CU A 12x16x1,5</p>	<p>K:← 069.540 46404094 AW/BS RD FPM 27x37x7</p> <p>K:→ 375.320 46539824 SP LD FPM 74</p> <p>N:← 290.710 55195339 AW/BS RD FPM 40x55x7</p>	
<p>069.630 46470334 FPM 16x</p>	<p>514.161 55222260</p> 	<p>AAS 334.670 77364551</p> 	<p>a) 030.793 Dirko HT</p> <p>b) 878.110 incl. 110.604 55184773 M 12x1,25x13</p> <p>b) 110.604 10261060 CU A 12x16x1,5</p>	<p>K:← 069.540 46404094 AW/BS RD FPM 27x37x7</p> <p>K:→ 375.320 46539824 SP LD FPM 74</p> <p>N:← 290.710 55195339 AW/BS RD FPM 40x55x7</p>	<p>TLS 796.230</p> 





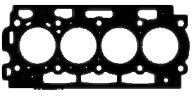
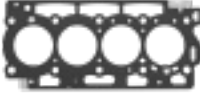



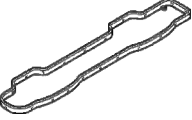





<p>FIAT</p> 				
<p>955 A6.000</p> <p>4 Cyl. 1368 ccm Cyl. 72,0 Ø</p> <p>Punto 03/2012 →</p> <p>Punto Evo 10/2009 → 02/2012</p>		<p>344.661 55202800 0,49 mm $\frac{3}{4}$ 72,4 Ø</p> 	<p>ZKS 111.590 7795992 (10x) M 9x1,25x87</p> 	<p>ZKHS 944.170 199.010 55194045</p>  <p>944.000 55233643</p>  <p>939.400 55233644 4x</p>
<p>955 A2.000 955 A8.000</p> <p>4 Cyl. 1368 ccm Cyl. 72,0 Ø</p> <p>Punto 09/2012 →</p> <p>Punto Evo 10/2009 → 02/2012</p> <p>Punto Multijet 03/2012 →</p>	<p>ES⊕ 944.190 CS 928.760</p>	<p>344.671 55206232 0,72 mm $\frac{3}{4}$ 72,4 Ø</p> 	<p>ZKS 111.590 7795992 (10x) M 9x1,25x87</p> 	<p>ZKHS 944.170 199.010 55194045</p>  <p>944.000 55233643</p>  <p>939.400 55233644 4x</p>
<p>EAF</p> <p>4 Cyl. 1368 ccm Cyl. 72,0 Ø</p> <p>500 09/2013 →</p>	<p>ES⊕ 928.770 Euro 5 CS 928.760</p>	<p>344.671 55206232 0,72 mm $\frac{3}{4}$ 72,4 Ø</p> 	<p>ZKS 111.590 7795992 (10x) M 9x1,25x87</p> 	<p>199.010 55194045</p> 
<p>EAM</p> <p>4 Cyl. 1368 ccm Cyl. 72,0 Ø</p> <p>124 Spider 03/2016 →</p> <p>500 09/2013 →</p> <p>500 L 09/2013 →</p> <p>500X 01/2016 →</p>	<p>ES⊕ 944.220 500L (351/352) CS 928.790</p>	<p>344.671 55206232 0,72 mm $\frac{3}{4}$ 72,4 Ø</p> 	<p>ZKS 111.590 7795992 (10x) M 9x1,25x87</p> 	<p>ZKHS 944.170 199.010 55194045</p>  <p>944.000 55233643</p>  <p>939.400 55233644 4x</p>





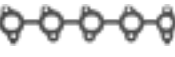





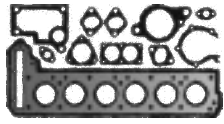
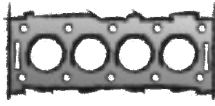

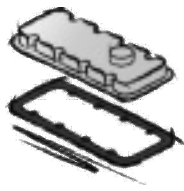

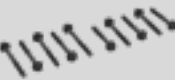
			<p>a) </p> <p>b) </p>	<p>K: </p> <p>N: </p>	
<p>069.630 46470334 FPM 16x</p>	<p>339.260 46526271</p> 		<p>a) 030.793 Dirko HT</p> <p>b) 878.110 incl. 110.604 55184773 M 12x1,25x13</p> <p>b) 110.604 10261060 CU A 12x16x1,5</p>	<p>K:← 069.540 46404094 AW/BS RD FPM 27x37x7</p> <p>K:→ 375.320 46539824 SP LD FPM 74</p> <p>N:← 688.580 55189997 AW/BS RD FPM 31x55x7</p>	
<p>069.630 46470334 FPM 16x</p>	<p>514.192 55225376</p> 	<p>AAS 334.670 77364551</p> 	<p>a) 030.793 Dirko HT</p> <p>b) 878.110 incl. 110.604 55184773 M 12x1,25x13</p> <p>b) 110.604 10261060 CU A 12x16x1,5</p>	<p>K:← 069.540 46404094 AW/BS RD FPM 27x37x7</p> <p>K:→ 375.320 46539824 SP LD FPM 74</p> <p>N:← 688.580 55189997 AW/BS RD FPM 31x55x7</p>	
<p>069.630 46470334 FPM 16x</p>	<p>514.161 55222260</p> 	<p>AAS 334.670 77364551</p> 	<p>a) 030.793 Dirko HT</p> <p>b) 878.110 incl. 110.604 55184773 M 12x1,25x13</p> <p>b) 110.604 10261060 CU A 12x16x1,5</p>	<p>K:← 069.540 46404094 AW/BS RD FPM 27x37x7</p> <p>K:→ 375.320 46539824 SP LD FPM 74</p> <p>N:← 290.710 55195339 AW/BS RD FPM 40x55x7</p>	
<p>069.630 46470334 FPM 16x</p>	<p>718.411 55278507</p> 	<p>AAS 334.670 77364551 500L (351/352)</p>  <p>AAS 926.370 77366687 124 (348) 500X (334)</p>	<p>a) 030.793 Dirko HT</p> <p>b) 878.110 incl. 110.604 55184773 M 12x1,25x13</p> <p>b) 110.604 10261060 CU A 12x16x1,5</p>	<p>K:← 069.540 46404094 AW/BS RD FPM 27x37x7</p> <p>K:→ 375.320 46539824 SP LD FPM 74</p> <p>N:← 688.580 55189997 AW/BS RD FPM 31x55x7</p>	<p>TLS 940.450</p>



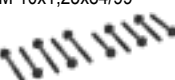



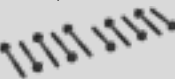





<p>FIAT</p> 				
<p>182 A3.000 182 A5.000</p> <p>4 Cyl. 1370 ccm Cyl. 82,0 Ø</p> <p>Brava 10/1995 → 10/2001</p> <p>Bravo 10/1995 → 10/2001</p> <p>Marea 09/1996 → 05/2002</p>	<p>S⊕* 710.392 ES⊕ 710.401 5895644</p>	<p>710.410 7744000</p> 		<p>375.190 7768026</p> 
<p>146 A8.000/046</p> <p>4 Cyl. 1372 ccm Cyl. 80,5 Ø</p> <p>Uno 01/1989 → 12/1991</p> <p>Uno Turbo 10/1988 → 08/2000</p>		<p>144.350 7710811 1,65 mm $\frac{2}{3}$ 81,5 Ø</p> 	<p>ZKS 760.870 46430687 (5x) +46430688 (5x) M 10x1,25x84/99</p> 	<p>462.713 7797034</p> <p>↑</p>  <p>435.361 7784728</p> <p>↓</p> 
<p>146 C1.000 146 C5.000 146 D5.000 159 A2.000 159A2038 160 A1.000/046/048 178 B2.000/016 836 A4.000</p> <p>4 Cyl. 1372 ccm Cyl. 80,5 Ø</p> <p>147 10/1980 → 10/1996</p> <p>Duna 07/1991 → 07/1996</p> <p>Elba 10/1993 → 02/1995</p> <p>Fiorino 01/1989 → 05/2001</p> <p>Palio 04/1996 → 10/2002</p> <p>Siena 04/1996 → 12/2009</p> <p>Tempra 04/1990 → 08/1996</p> <p>Tipo 07/1987 → 04/1995</p> <p>Uno 10/1988 → 06/2006</p>	<p>ES⊕ 144.281 5892411 +40004940</p>	<p>144.140 7666858 1,65 mm $\frac{2}{3}$ 81 Ø</p> 	<p>ZKS 760.870 46430687 (5x) +46430688 (5x) M 10x1,25x84/99</p> 	<p>462.713 7797034</p> <p>↑</p>  <p>435.361 7784728</p> <p>↓</p> 
<p>176 A4.000 176 B6.000</p> <p>4 Cyl. 1372 ccm Cyl. 80,5 Ø</p> <p>Punto 10/1993 → 07/1999</p>	<p>ES⊕ 529.620 ● 5893693 +40004940 (2x)</p>	<p>144.350 7710811 1,65 mm $\frac{2}{3}$ 81,5 Ø</p> 	<p>ZKS 760.870 46430687 (5x) +46430688 (5x) M 10x1,25x84/99</p> 	<p>462.713 7797034</p> <p>↑</p>  <p>435.361 7784728</p> <p>↓</p> 







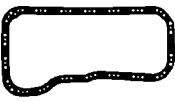

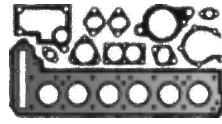
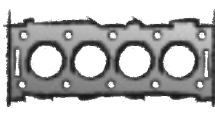

			<p>a) </p> <p>b) </p>	<p>K: </p> <p>N: </p>	
<p>VAS 825.050 FPM 701.289 46436047 FPM 12x</p>	<p>431.390 46427653 </p>			<p>K:← 069.590 7628850 AW/BS RD FPM 31x41x7 K:→ 199.191 71718365 SP LD FPM 93x12 N:← 505.838 60809849 ASW RD FPM 30x42x7</p>	
<p>VAS 294.250 FPM 294.110 7553637 FPM 8x</p>			<p>a) 435.410 7663366 </p> <p>b) 587.100 7734022 M 22x1,5x13</p>	<p>K:← 440.760 40004950 AW/B RD FPM 40x56x7 K:→ 440.780 40004280 AW/BS LD ACM 64x80x8 N:← 440.750 40004940 AW/BS RD FPM 30x52x7</p>	
<p>VAS 294.250 FPM 294.110 7553637 FPM 8x</p>	<p>⇒ </p>	<p>435.372 7772495 </p>	<p>a) 435.410 7663366 </p> <p>b) 587.100 7734022 M 22x1,5x13</p>	<p>K:← 440.760 40004950 AW/B RD FPM 40x56x7 K:→ 440.780 40004280 AW/BS LD ACM 64x80x8 N:← 440.750 40004940 AW/BS RD FPM 30x52x7</p>	
<p>VAS 294.250 FPM 294.110 7553637 FPM 8x</p>			<p>a) 435.410 7663366 </p> <p>b) 587.100 7734022 M 22x1,5x13</p>	<p>K:← 440.760 40004950 AW/B RD FPM 40x56x7 K:→ 199.180 46416876 IWD LD FPM 64x20 N:← 440.750 40004940 AW/BS RD FPM 30x52x7</p>	

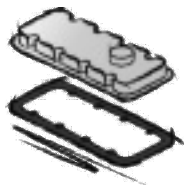

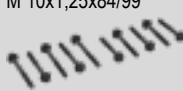
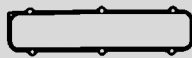

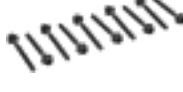

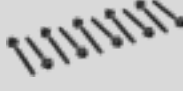

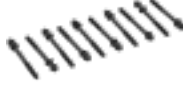
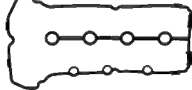





<p>FIAT</p> 				
<p>9H07 (DV6UC) 9HM (DV6UC)</p> <p>4 Cyl. 1560 ccm Cyl. 75,0 Ø</p> <p>Scudo Multijet 02/2011 →</p>	<p>S⊕* 726.090</p>  <p>ES⊕ 570.910</p>  <p>ES⊕ 995.620</p>  <p>CS* 449.590 OKS 027.170</p>  <p>OKS 747.080</p> 	<p>718.311 9676157680 1,25 mm $\frac{\pm}{\pm}$ 76,3 Ø 2 ∇</p>  <p>718.321 9676157980 1,30 mm $\frac{\pm}{\pm}$ 76,3 Ø 3 ∇</p> <p>718.331 9676157480 1,35 mm $\frac{\pm}{\pm}$ 76,3 Ø 1 ∇</p>  <p>718.341 9676158080 1,40 mm $\frac{\pm}{\pm}$ 76,3 Ø 4 ∇</p>  <p>718.351 9676158280 1,45 mm $\frac{\pm}{\pm}$ 76,3 Ø 5 ∇</p>	<p>ZKS 330.390 9642546980 (10x) M 11x1,5x147</p> 	<p>453.420 9670015280</p> 
<p>9HU</p> <p>4 Cyl. 1560 ccm Cyl. 75,0 Ø</p> <p>Scudo Multijet 01/2007 →</p>	<p>S⊕* 456.780</p>  <p>S⊕* 726.090</p>  <p>ES⊕ 569.410</p>  <p>CS* 030.780 OKS 027.170</p>  <p>OKS 747.080</p> 	<p>569.812 9682252980 0,533 mm → 0,634 mm 1,25 mm $\frac{\pm}{\pm}$ 76 Ø 2 ⊗ 2 ∇</p>  <p>569.822 9682253080 0,635 mm → 0,684 mm 1,30 mm $\frac{\pm}{\pm}$ 76 Ø 3 ⊗ 3 ∇</p>  <p>569.802 9682252880 0,685 mm → 0,734 mm 1,35 mm $\frac{\pm}{\pm}$ 76 Ø 1 ⊗ 1 ∇</p>  <p>569.832 9682253280 0,735 mm → 0,784 mm 1,40 mm $\frac{\pm}{\pm}$ 76 Ø 4 ⊗ 4 ∇</p>  <p>569.842 9682253480 0,785 mm → 0,886 mm 1,45 mm $\frac{\pm}{\pm}$ 76 Ø 5 ⊗ 5 ∇</p> 	<p>ZKS 330.390 9642546980 (10x) M 11x1,5x147</p> 	<p>375.510 9641964380</p> 





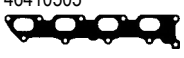
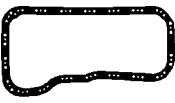

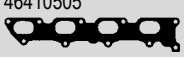
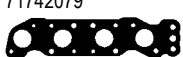

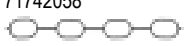

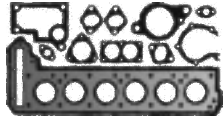
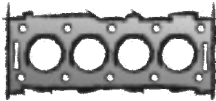

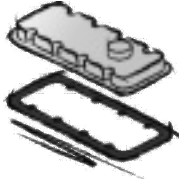

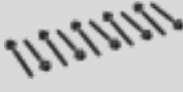

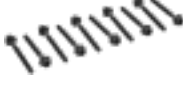

			<p>a) </p> <p>b) </p>	<p>K: </p> <p>N: </p>	
<p>VAS 261.330 FPM 027.750 9637236280 FPM 8x</p>	<p>374.940 9672188780</p> 	<p>341.080</p> 	<p>a) 036.164 Dirko HT / EU</p> <p>a) 510.031 Dirko HT / USA/CDN/MEX</p> <p>a) 527.291 Dirko HT / RU</p> <p>a) 648.661 Dirko HT / BR</p> <p>b) 877.930 incl. 108.502 M 10x1,25x13</p> <p>b) 108.502 9400313409 CU A 10x21x2,1</p>	<p>K:← 026.750 9456202980 ASW RD PTFE/FPM 40x55x6,4</p> <p>K:→ 026.790 9456203080 ASW LD PTFE/FPM 85x105x8,8</p> <p>N:← 026.740 9456202880 ASW RD PTFE/ACM 27x47x7</p>	<p>TLS 430.160</p> 
<p>262.650 9639780080 FPM 16x</p>	<p>761.041 9639808580</p> 	<p>AAS 429.040</p>  <p>389.041 9649829580 4x</p>  <p>389.121 9649829380 4x</p> 	<p>a) 036.164 Dirko HT / EU</p> <p>a) 510.031 Dirko HT / USA/CDN/MEX</p> <p>a) 527.291 Dirko HT / RU</p> <p>a) 648.661 Dirko HT / BR</p> <p>b) 877.930 incl. 108.502 M 10x1,25x13</p> <p>b) 108.502 9400313409 CU A 10x21x2,1</p>	<p>K:← 026.750 9456202980 ASW RD PTFE/FPM 40x55x6,4</p> <p>K:→ 026.790 9456203080 ASW LD PTFE/FPM 85x105x8,8</p> <p>N:← 026.740 9456202880 ASW RD PTFE/ACM 27x47x7</p>	<p>TLS 714.600</p> 



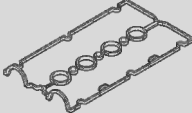











<p>FIAT</p> 				
<p>146 B6.011 146 B7.011 146 C6.000 146 D6.000 159 A3.000/046/048 160 A2.000/011</p> <p>4 Cyl. 1581 ccm Cyl. 86,4 Ø</p> <p>Duna 11/1994 → 09/2000</p> <p>Elba 03/1988 → 12/1997</p> <p>Fiorino 01/1990 → 05/2001</p> <p>Premio 03/1985 → 12/1996</p> <p>Regata 09/1983 → 08/1995</p> <p>Siena 09/1997 → 03/2000</p> <p>Tempra 03/1990 → 08/1996</p> <p>Tipo 01/1988 → 12/1996</p> <p>Uno 01/1989 → 12/1995</p>	<p>ES⊕ 144.291 5892379</p>	<p>144.150 46414567 1,65 mm $\frac{3}{16}$ 87 Ø</p> 	<p>ZKS 760.870 46430687 (5x) +46430688 (5x) M 10x1,25x84/99</p> 	<p>462.713 7797034</p> <p>↑</p>  <p>435.361 7784728</p> <p>↓</p> 
<p>159 B9.000 160 E1.011 160 E2.011 835 C1.000</p> <p>4 Cyl. 1581 ccm Cyl. 86,4 Ø</p> <p>Fiorino 10/1995 → 10/1996</p> <p>Tempra 03/1990 → 08/1996</p> <p>Tipo 10/1992 → 05/1997</p>		<p>144.150 46414567 1,65 mm $\frac{3}{16}$ 87 Ø</p> 	<p>ZKS 760.870 46430687 (5x) +46430688 (5x) M 10x1,25x84/99</p> 	<p>462.713 7797034</p> <p>↑</p>  <p>435.361 7784728</p> <p>↓</p> 
<p>176 A9.000</p> <p>4 Cyl. 1581 ccm Cyl. 86,4 Ø</p> <p>Punto 01/1994 → 04/1997</p>	<p>ES⊕ 529.500 5894257 +40004940 (2x)</p>	<p>144.150 46414567 1,65 mm $\frac{3}{16}$ 87 Ø</p> 	<p>ZKS 760.870 46430687 (5x) +46430688 (5x) M 10x1,25x84/99</p> 	<p>462.713 7797034</p> <p>↑</p>  <p>435.361 7784728</p> <p>↓</p> 



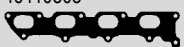







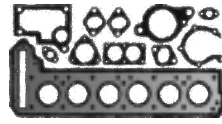
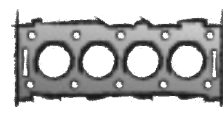

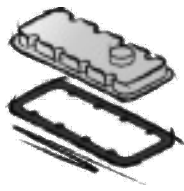



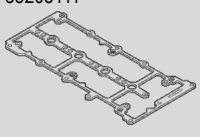

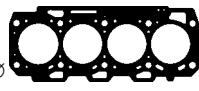

			<p>a) </p> <p>b) </p>	<p>K: </p> <p>N: </p>	
<p>VAS 294.250 FPM 294.110 7553637 FPM 8x</p>	<p>⇒</p>	<p>435.372 7772495</p> 	<p>a) 435.410 7663366</p>  <p>b) 587.100 7734022 M 22x1,5x13</p>	<p>K:← 440.760 40004950 AW/B RD FPM 40x56x7</p> <p>K:→ 440.780 40004280 AW/BS LD ACM 64x80x8</p> <p>N:← 440.750 40004940 AW/BS RD FPM 30x52x7</p>	
<p>VAS 294.250 FPM 294.110 7553637 FPM 8x</p>	<p>⇒</p>	<p>435.372 7772495</p> 	<p>a) 435.410 7663366</p>  <p>b) 587.100 7734022 M 22x1,5x13</p>	<p>K:← 440.760 40004950 AW/B RD FPM 40x56x7</p> <p>K:→ 440.780 40004280 AW/BS LD ACM 64x80x8</p> <p>N:← 440.750 40004940 AW/BS RD FPM 30x52x7</p>	
<p>VAS 294.250 FPM 294.110 7553637 FPM 8x</p>	<p>⇒</p>	<p>189.768 7684082 2x</p> 	<p>a) 435.410 7663366</p>  <p>b) 587.100 7734022 M 22x1,5x13</p>	<p>K:← 440.760 40004950 AW/B RD FPM 40x56x7</p> <p>K:→ 199.180 46416876 IWD LD FPM 64x20 01/1996→</p> <p>N:← 440.750 40004940 AW/BS RD FPM 30x52x7</p>	

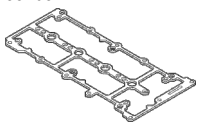



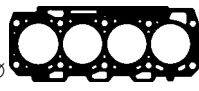



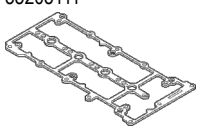







<p>FIAT</p> 				
<p>178 C1.011 178 C8.011 220 A 2.000</p> <p>4 Cyl. 1581 ccm Cyl. 86,4 Ø</p> <p>Palio 02/1997 → 12/2001</p> <p>Scudo 02/1996 → 12/2006</p> <p>Strada 11/1998 → 12/2000</p>		<p>144.150 46414567 1,65 mm ± 87 Ø</p> 	<p>ZKS 760.870 46430687 (5x) +46430688 (5x) M 10x1,25x84/99</p> 	<p>462.713 7797034 ↑</p>  <p>435.361 7784728 ↓</p> 
<p>178 A8.011 178 B3.000 178 C7.098 178 D2.011 182 A4.000 182 A6.000</p> <p>4 Cyl. 1581 ccm Cyl. 86,4 Ø</p> <p>Brava 10/1995 → 10/2001</p> <p>Bravo 10/1995 → 10/2001</p> <p>Marea 09/1996 → 05/2002</p> <p>Multipla 04/1999 → 06/2010</p> <p>Palio 04/1996 →</p> <p>Siena 10/1997 → 12/2009</p> <p>Strada 02/1998 →</p>	<p>S⊕* 710.360 5895664</p> <p>ES⊕ 710.370 5895663</p>	<p>710.380 46410960 87 Ø</p> 	<p>ZKS 104.270 7758731 (10x) M 10x1,25x101</p> 	<p>861.510 46467203</p> 
<p>182 B5.098 185 A3.000 186 A3.000 186 A4.000</p> <p>4 Cyl. 1581 ccm Cyl. 86,4 Ø</p> <p>Marea 04/1997 → 08/2002</p> <p>Multipla 04/1999 → 06/2010</p>	<p>S⊕* 710.360 5895664</p> <p>ES⊕ 710.370 5895663</p>	<p>710.380 46410960 87 Ø</p> 	<p>ZKS 104.270 7758731 (10x) M 10x1,25x101</p> 	<p>861.510 46467203 2x</p> 
<p>M16A</p> <p>4 Cyl. 1586 ccm Cyl. 78,0 Ø</p> <p>Sedici 06/2006 → 10/2014</p>	<p>S⊕ 694.350 →06/2009</p> <p>ES⊕ 747.340 →06/2009</p> <p>ES⊕ 994.470 →06/2009</p> <p>CS* 747.350</p>	<p>198.680 71741918 0,70 mm ± 79 Ø</p> 	<p>ZKS 452.740 71741916 (10x) M 10x1,5x120</p> 	<p>735.700 71746931</p> 











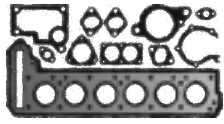
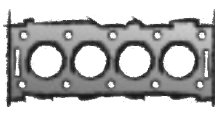

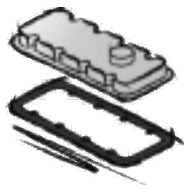



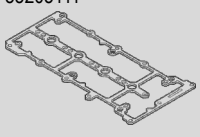

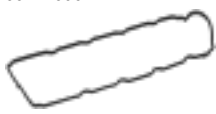
			<p>a) </p> <p>b) </p>	<p>K: </p> <p>N: </p>	
<p>VAS 294.250 FPM 294.110 7553637 FPM 8x</p>	<p>⇒</p>	<p>435.372 7772495 </p>	<p>a) 435.410 7663366 </p> <p>b) 587.100 7734022 M 22x1,5x13</p>	<p>K:← 440.760 40004950 AW/B RD FPM 40x56x7 K:→ 440.780 40004280 AW/BS LD ACM 64x80x8 →Mot. 9504512 K:→ 199.180 46416876 IWD LD FPM 64x20 Mot. 9504513→ N:← 440.750 40004940 AW/BS RD FPM 30x52x7</p>	
<p>VAS 825.042 FPM 2x 701.289 46436047 FPM 16x</p>	<p>332.210 46820225 </p>	<p>375.290 46410505 </p>	<p>a) 435.410 7663366 →Mot. 9508753 </p> <p>a) 030.793 Dirko HT Mot. 9508754→ b) 587.100 7734022 M 22x1,5x13</p>	<p>K:← 440.760 40004950 AW/B RD FPM 40x56x7 K:→ 440.780 40004280 AW/BS LD ACM 64x80x8 →Mot. 9508753 K:→ 199.180 46416876 IWD LD FPM 64x20 Mot. 9508754→ N:← 440.750 40004940 AW/BS RD FPM 30x52x7 2x</p>	
<p>VAS 825.042 FPM 2x 701.289 46436047 FPM 16x</p>	<p>332.210 46820225 </p>	<p>375.290 46410505 </p>	<p>a) 030.793 Dirko HT b) 587.100 7734022 M 22x1,5x13</p>	<p>K:← 440.760 40004950 AW/B RD FPM 40x56x7 K:→ 199.180 46416876 IWD LD FPM 64x20 N:← 440.750 40004940 AW/BS RD FPM 30x52x7 2x</p>	
<p>166.190 71741827 FPM 16x</p>	<p>198.720 71742079  475.030 71742079 </p>	<p>735.710 71742058 </p>	<p>a) 036.164 Dirko HT / EU a) 510.031 Dirko HT / USA/CDN/MEX a) 527.291 Dirko HT / RU a) 648.661 Dirko HT / BR b) 243.205 AL A 14x20x1,5</p>	<p>K:← 717.710 71741822 AS RD FPM 41x53x6 K:→ 736.810 71741826 AS LD FPM 83x103x8</p>	



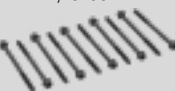
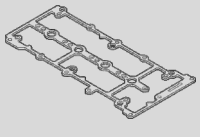





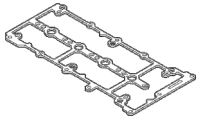









FIAT 				
178 E7.000 4 Cyl. 1596 ccm Cyl. 80,5 Ø Palio 06/2006 →	S⊕* 198.880 71718143 →Mot. 505168 S⊕* 198.910 71718853 Mot. 505169→ ES⊕ 198.890 71718142 →Mot. 505168 ES⊕ 198.920 71718852 Mot. 505169→	198.870 46752127 1,80 mm $\frac{\pm}{\pm}$ 80,8 Ø  →Mot. 505168 761.293 55199125 0,49 mm $\frac{\pm}{\pm}$ 81,5 Ø  Mot. 505169→	ZKS 104.270 7758731 (10x) M 10x1,25x101 	861.510 46467203 2x 
182 B6.000 4 Cyl. 1596 ccm Cyl. 80,5 Ø Brava 01/1999 → 06/2003 Bravo 09/2000 → 10/2001 Doblo 03/2001 → Marea 09/2000 → 12/2007 Multipla 09/2000 → 06/2010 Palio 06/1996 → Siena 11/2000 → 12/2012 Stilo 10/2001 → 08/2008	S⊕* 198.880 71718143 →Mot. 505168 S⊕* 198.910 71718853 Mot. 505169→ ES⊕ 198.890 71718142 →Mot. 505168 ES⊕ 319.470 →Mot. 505168 ES⊕ 198.920 71718852 Mot. 505169→ ES⊕ 319.550 Mot. 505169→	198.870 46752127 1,80 mm $\frac{\pm}{\pm}$ 80,8 Ø  →Mot. 505168 761.293 55199125 0,49 mm $\frac{\pm}{\pm}$ 81,5 Ø  Mot. 505169→	ZKS 104.270 7758731 (10x) M 10x1,25x101 	861.510 46467203 2x 
192 B3.000 4 Cyl. 1598 ccm Cyl. 79,0 Ø Stilo 03/2005 → 08/2008	ES⊕ 388.210 CS* 655.460	808.524 71739872 0,45 mm $\frac{\pm}{\pm}$ 80,2 Ø 	ZKS 803.060 71739839 (10x) M 10x1,25x153 	388.200 71739809 
198 A3.000 4 Cyl. 1598 ccm Cyl. 79,5 Ø Bravo JTD 03/2008 → 12/2014 Bravo Multijet 09/2007 → 12/2014 Doblo Multijet 01/2010 → Linea Multijet 06/2009 →	ES⊕ 399.870 71769851 Bravo (198) Mot. 6491051→ Doblo (263) Linea 323 Mot. 6490517→  CS* 592.910 71749743 +71718365	789.180 55221093 0,82 mm $\frac{\pm}{\pm}$ 80,5 Ø  789.190 55221094 0,92 mm $\frac{\pm}{\pm}$ 80,5 Ø  1 ⊗ 789.200 55221095 1,02 mm $\frac{\pm}{\pm}$ 80,5 Ø  2 ⊗	ZKS 524.160 55214378 (10x) M 12x1,25x98 	748.591 55205111 









			<p>a) </p> <p>b) </p>	<p>K: </p> <p>N: </p>	
<p>VAS 825.042 FPM 2x 701.289 46436047 FPM 16x</p>	<p>332.210 46820225 </p>	<p>375.290 46410505 </p>	<p>a) 030.793 Dirko HT b) 587.100 7734022 M 22x1,5x13</p>	<p>K:← 440.760 40004950 AW/B RD FPM 40x56x7 K:→ 199.180 46416876 IWD LD FPM 64x20 N:← 440.750 40004940 AW/BS RD FPM 30x52x7 2x</p>	
<p>VAS 825.042 FPM 2x 701.289 46436047 FPM 16x</p>	<p>332.210 46820225 </p>	<p>375.290 46410505 </p>	<p>a) 030.793 Dirko HT b) 587.100 7734022 M 22x1,5x13</p>	<p>K:← 440.760 40004950 AW/B RD FPM 40x56x7 K:→ 199.180 46416876 IWD LD FPM 64x20 N:← 440.750 40004940 AW/BS RD FPM 30x52x7 2x</p>	
<p>061.760 71739773 FPM 16x</p>	<p>808.610 71739785 </p>	<p>809.241 71739818 </p>	<p>a) 036.164 Dirko HT / EU a) 510.031 Dirko HT / USA/CDN/MEX a) 527.291 Dirko HT / RU a) 648.661 Dirko HT / BR b) 274.410 46823509 M 14x1,5x13,5 b) 587.100 7734022 M 22x1,5x13 b) 476.750 FPM RD 18x22x2</p>	<p>K:← 056.900 71739825 A/BS RD FPM 31,5x42x7 K:→ 590.797 A/BS LD FPM 80x98x10 →Mot. 20DS3627 K:→ 434.550 ASW LD PTFE/FPM 80x98x14,6 Mot. 20DS3628→ N:← 702.269 AW/BS RD VMQ 35x48x7 2x</p>	
<p>506.550 55183812 FPM 16x</p>	<p>748.510 55210879 </p>	<p>AAS 340.470 71754211 </p>	<p>a) 030.793 Dirko HT b) 877.920 incl. 339.580 46476967 M 18x1,5x22 b) 878.030 incl. 359.300 M 18x1,5x20 b) 339.580 55196309 CU A 18x26x1,5 b) 359.300 FPM A 18x26x1,5 FE/FPM</p>	<p>K:← 069.590 7628850 AW/BS RD FPM 31x41x7 K:→ 199.191 71718365 SP LD FPM 93x12 N:← 434.500 46802577 A/BS RD FPM 30x45x7</p>	

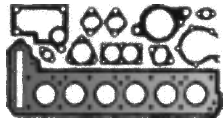
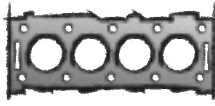

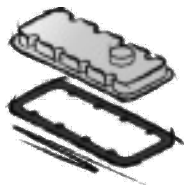

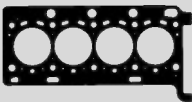
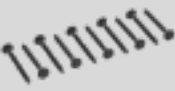

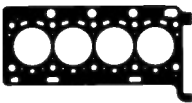
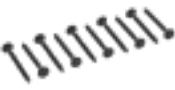



<p>FIAT</p> 				
<p>199 B5.000 4 Cyl. 1598 ccm Cyl. 79,5 Ø</p> <p>500 L Multijet 09/2012 → 05/2018</p>		<p>789.180 55221093 0,82 mm $\frac{\pm}{\pm}$ 80,5 Ø </p> <p>789.190 55221094 0,92 mm $\frac{\pm}{\pm}$ 80,5 Ø </p> <p>789.200 55221095 1,02 mm $\frac{\pm}{\pm}$ 80,5 Ø </p>	<p>ZKS 524.160 55214378 (10x) M 12x1,25x98</p> 	<p>748.591 55205111</p> 
<p>263 A3.000 263 A4.000 263 A5.000 263 A7.000 263 A8.000 263 A9.000</p> <p>4 Cyl. 1598 ccm Cyl. 79,5 Ø</p> <p>Doblo Multijet 01/2010 →</p>	<p>ES⊕ 399.870 71769851 Mot. 6490517→</p>  <p>CS* 592.910 71749743 +71718365</p>	<p>789.180 55221093 0,82 mm $\frac{\pm}{\pm}$ 80,5 Ø </p> <p>789.190 55221094 0,92 mm $\frac{\pm}{\pm}$ 80,5 Ø </p> <p>789.200 55221095 1,02 mm $\frac{\pm}{\pm}$ 80,5 Ø </p>	<p>ZKS 524.160 55214378 (10x) M 12x1,25x98</p> 	<p>748.591 55205111</p> 
<p>310 A5.011</p> <p>4 Cyl. 1598 ccm Cyl. 77,0 Ø</p> <p>Grande Punto 02/2011 →</p> <p>Grand Siena 03/2012 →</p> <p>Idea 08/2010 →</p> <p>Linea 10/2011 →</p> <p>Palio 08/2010 →</p> <p>Punto 07/2010 →</p> <p>Sienna 08/2010 → 10/2013</p> <p>Strada 09/2009 →</p>	<p>ES⊕ 706.440 CS* 903.590</p>	<p>939.490 55263732 0,65 mm $\frac{\pm}{\pm}$ 78 Ø </p>	<p>ZKS 949.360 55223509 (10x) M 10x1,5x148</p>	<p>ZKHS 763.880 518.030 55247838</p> 
<p>198 A2.000 198 A6.000 350 A2.000 350 A3.000 844 A3.000 955 A4.000</p> <p>4 Cyl. 1598 ccm Cyl. 79,5 Ø</p> <p>Bravo Multijet 09/2007 → 12/2014</p> <p>Idea Multijet 05/2008 →</p>	<p>ES⊕ 399.870 71769851 Mot. 6491051→</p>  <p>CS* 592.910 71749743 +71718365</p>	<p>789.180 55221093 0,82 mm $\frac{\pm}{\pm}$ 80,5 Ø </p> <p>789.190 55221094 0,92 mm $\frac{\pm}{\pm}$ 80,5 Ø </p> <p>789.200 55221095 1,02 mm $\frac{\pm}{\pm}$ 80,5 Ø </p>	<p>ZKS 524.160 55214378 (10x) M 12x1,25x98</p> 	<p>748.591 55205111</p> 











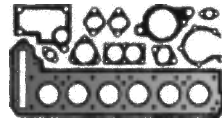
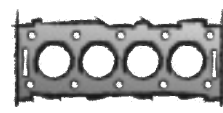

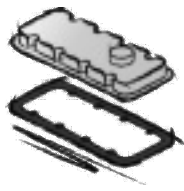













			<p>a) </p> <p>b) </p>	<p>K: </p> <p>N: </p>	
<p>506.550 55183812 FPM 16x</p>	<p>748.510 55210879</p> 	<p>AAS 340.470 71754211</p> 	<p>a) 030.793 Dirko HT</p> <p>b) 877.920 incl. 339.580 46476967 M 18x1,5x22</p> <p>b) 878.030 incl. 359.300 M 18x1,5x20</p> <p>b) 339.580 55196309 CU A 18x26x1,5</p> <p>b) 359.300 FPM A 18x26x1,5 FE/FPM</p>	<p>K:← 069.590 7628850 AW/BS RD FPM 31x41x7</p> <p>K:→ 199.191 71718365 SP LD FPM 93x12</p> <p>N:← 434.500 46802577 A/BS RD FPM 30x45x7</p>	
<p>506.550 55183812 FPM 16x</p>	<p>748.510 55210879</p> 	<p>AAS 340.470 71754211</p> 	<p>a) 030.793 Dirko HT</p> <p>b) 877.920 incl. 339.580 46476967 M 18x1,5x22</p> <p>b) 878.030 incl. 359.300 M 18x1,5x20</p> <p>b) 339.580 55196309 CU A 18x26x1,5</p> <p>b) 359.300 FPM A 18x26x1,5 FE/FPM</p>	<p>K:← 069.590 7628850 AW/BS RD FPM 31x41x7</p> <p>K:→ 199.191 71718365 SP LD FPM 93x12</p> <p>N:← 434.500 46802577 A/BS RD FPM 30x45x7</p>	
<p>VAS 708.100 FPM</p> <p>026.650 55263053 FPM 16x</p> 	<p>571.770 55224457</p>	<p>939.340 7090012 55263732 4x</p> 	<p>a) 485.960 55226126</p>  <p>b) 012.001 9659107280 M 14x1,5x20</p> <p>b) 176.090 13x22,4x3</p>	<p>K:← 583.050 7089564 AS RD FPM 32x45x6</p> <p>K:→ 902.760 55223567 A/BS LD FPM 91x111x9</p>	
<p>506.550 55183812 FPM 16x</p>	<p>748.510 55210879</p> 	<p>AAS 340.470 71754211</p> 	<p>a) 030.793 Dirko HT</p> <p>b) 877.920 incl. 339.580 46476967 M 18x1,5x22</p> <p>b) 878.030 incl. 359.300 M 18x1,5x20</p> <p>b) 339.580 55196309 CU A 18x26x1,5</p> <p>b) 359.300 FPM A 18x26x1,5 FE/FPM</p>	<p>K:← 069.590 7628850 AW/BS RD FPM 31x41x7</p> <p>K:→ 199.191 71718365 SP LD FPM 93x12</p> <p>N:← 434.500 46802577 A/BS RD FPM 30x45x7</p>	













<p>FIAT</p> 				
<p>552 60 384 552 80 444</p> <p>4 Cyl. 1598 ccm Cyl. 79,5 Ø</p> <p>500 L Multijet 09/2013 →</p> <p>500X Multijet 09/2014 →</p> <p>Tipo 10/2015 →</p>		<p>789.180 55221093 0,82 mm $\frac{3}{4}$ 80,5 Ø </p> <p>789.190 55221094 0,92 mm $\frac{3}{4}$ 80,5 Ø </p> <p>789.200 55221095 1,02 mm $\frac{3}{4}$ 80,5 Ø </p>	<p>ZKS 524.160 55214378 (10x) M 12x1,25x98</p> 	<p>748.591 55205111</p> 
<p>552 63 842 552 68 036</p> <p>4 Cyl. 1598 ccm Cyl. 77,0 Ø</p> <p>500X 11/2014 →</p> <p>Tipo 10/2015 →</p>	<p>ES⊕ 706.440 CS* 903.590</p>	<p>939.490 55263732 0,65 mm $\frac{3}{4}$ 78 Ø </p>	<p>ZKS 949.360 55223509 (10x) M 10x1,5x148</p>	<p>ZKHS 763.880 518.030 55247838</p> 
<p>940 C1.000</p> <p>4 Cyl. 1598 ccm Cyl. 79,5 Ø</p> <p>500 L Multijet 09/2013 →</p> <p>Doblo Multijet 03/2015 →</p> <p>Tipo 10/2015 →</p>		<p>789.180 55221093 0,82 mm $\frac{3}{4}$ 80,5 Ø </p> <p>789.190 55221094 0,92 mm $\frac{3}{4}$ 80,5 Ø </p> <p>789.200 55221095 1,02 mm $\frac{3}{4}$ 80,5 Ø </p>	<p>ZKS 524.160 55214378 (10x) M 12x1,25x98</p> 	<p>748.591 55205111</p> 
<p>955 A3.000</p> <p>4 Cyl. 1598 ccm Cyl. 79,5 Ø</p> <p>500 L Multijet 09/2013 →</p> <p>Grande Punto Multijet 07/2008 →</p> <p>Punto Evo Multijet 10/2009 → 02/2012</p>	<p>ES⊕ 399.870 71769851 Punto Evo (199) G. Punto 199 Mot. 6491051→</p>  <p>CS* 592.910 71749743 +71718365</p>	<p>789.180 55221093 0,82 mm $\frac{3}{4}$ 80,5 Ø </p> <p>789.190 55221094 0,92 mm $\frac{3}{4}$ 80,5 Ø </p> <p>789.200 55221095 1,02 mm $\frac{3}{4}$ 80,5 Ø </p>	<p>ZKS 524.160 55214378 (10x) M 12x1,25x98</p> 	<p>748.591 55205111</p> 









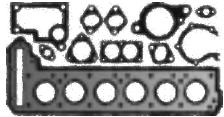
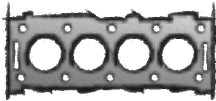

			<p>a) </p> <p>b) </p>	<p>K: </p> <p>N: </p>	
<p>506.550 55183812 FPM 16x</p>	<p>907.400 Euro 6</p> 	<p>AAS 340.470 71754211</p> 	<p>a) 030.793 Dirko HT</p> <p>b) 877.920 incl. 339.580 46476967 M 18x1,5x22</p> <p>b) 878.030 incl. 359.300 M 18x1,5x20</p> <p>b) 339.580 55196309 CU A 18x26x1,5</p> <p>b) 359.300 FPM A 18x26x1,5 FE/FPM</p>	<p>K:← 069.590 7628850 AW/BS RD FPM 31x41x7</p> <p>K:→ 199.191 71718365 SP LD FPM 93x12</p> <p>N:← 434.500 46802577 A/BS RD FPM 30x45x7</p>	<p>TLS 651.340</p>
<p>VAS 708.100 FPM</p> <p>026.650 55263053 FPM 16x</p> 	<p>012.280 51961224</p> 	<p>939.340 7090012 55263732 4x</p> 	<p>a) 485.960 55226126</p>  <p>b) 012.001 9659107280 M 14x1,5x20</p> <p>b) 176.090 13x22,4x3</p>	<p>K:← 583.050 7089564 AS RD FPM 32x45x6</p> <p>K:→ 902.760 55223567 A/BS LD FPM 91x111x9</p>	
<p>506.550 55183812 FPM 16x</p>	<p>907.400 Euro 6</p> 	<p>AAS 340.470 71754211</p> 	<p>a) 030.793 Dirko HT</p> <p>b) 877.920 incl. 339.580 46476967 M 18x1,5x22</p> <p>b) 878.030 incl. 359.300 M 18x1,5x20</p> <p>b) 339.580 55196309 CU A 18x26x1,5</p> <p>b) 359.300 FPM A 18x26x1,5 FE/FPM</p>	<p>K:← 069.590 7628850 AW/BS RD FPM 31x41x7</p> <p>K:→ 199.191 71718365 SP LD FPM 93x12</p> <p>N:← 434.500 46802577 A/BS RD FPM 30x45x7</p>	
<p>506.550 55183812 FPM 16x</p>	<p>748.510 55210879</p> 	<p>AAS 340.470 71754211</p> 	<p>a) 030.793 Dirko HT</p> <p>b) 877.920 incl. 339.580 46476967 M 18x1,5x22</p> <p>b) 878.030 incl. 359.300 M 18x1,5x20</p> <p>b) 339.580 55196309 CU A 18x26x1,5</p> <p>b) 359.300 FPM A 18x26x1,5 FE/FPM</p>	<p>K:← 069.590 7628850 AW/BS RD FPM 31x41x7</p> <p>K:→ 199.191 71718365 SP LD FPM 93x12</p> <p>N:← 434.500 46802577 A/BS RD FPM 30x45x7</p>	

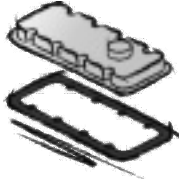

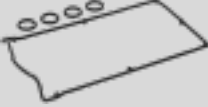





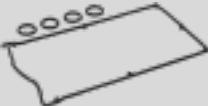





<p>FIAT</p> 				
<p>R9M 408/413</p> <p>4 Cyl. 1598 ccm Cyl. 80,0 Ø</p> <p>Talento 06/2016 →</p>	<p>S⊕* 928.890 ES⊕ 634.670 6000616499 CS* 702.570 6000616498 OKS 634.600</p> 	<p>867.700 6000616557 1,25 mm $\frac{1}{2}$ 81 Ø</p> 	<p>ZKS 481.900 6000616532 M 12x1,5x135</p> 	<p>ZKHS 632.580 6000616812</p> 
<p>R9M 450/452</p> <p>4 Cyl. 1598 ccm Cyl. 80,0 Ø</p> <p>Talento 06/2016 →</p>	<p>S⊕* 928.940 ES⊕ 811.220 CS* 702.570 6000616498 OKS 634.600</p> 	<p>867.700 6000616557 1,25 mm $\frac{1}{2}$ 81 Ø</p> 	<p>ZKS 481.900 6000616532 M 12x1,5x135</p> 	<p>ZKHS 632.580 6000616812</p> 









			<p>a) </p> <p>b) </p>	<p>K: </p> <p>N: </p>	
<p>VAS 424.800 FPM 403.730 9400956389 FPM 16x</p>	<p>290.821 6000620259</p> 	<p>365.060 6000616721</p>	<p>a) 036.164 Dirko HT / EU</p> <p>a) 510.031 Dirko HT / USA/CDN/MEX</p> <p>a) 527.291 Dirko HT / RU</p> <p>a) 648.661 Dirko HT / BR</p> <p>b) 434.941 M 16x1,5x12 incl. 813.052</p> <p>b) 813.052 CU C 16x22x2</p> <p>b) 834.823 9400164889 NBR A 16,7x24x1,5 FE/NBR</p>	<p>K:← 260.320 6000616591 SP RD PTFE 50x81x11,5</p> <p>K:→ 650.330 6000616906 LD FPM 96</p>	<p>TLS 642.470</p> 
<p>VAS 424.800 FPM 403.730 9400956389 FPM 16x</p>	<p>798.150 6000616722</p> 	<p>365.060 6000616721</p>	<p>a) 036.164 Dirko HT / EU</p> <p>a) 510.031 Dirko HT / USA/CDN/MEX</p> <p>a) 527.291 Dirko HT / RU</p> <p>a) 648.661 Dirko HT / BR</p> <p>b) 434.941 M 16x1,5x12 incl. 813.052</p> <p>b) 813.052 CU C 16x22x2</p> <p>b) 834.823 9400164889 NBR A 16,7x24x1,5 FE/NBR</p>	<p>K:← 260.320 6000616591 SP RD PTFE 50x81x11,5</p> <p>K:→ 650.330 6000616906 LD FPM 96</p>	<p>TLS 811.050</p>

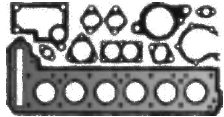
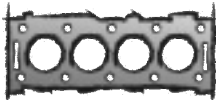

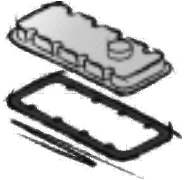
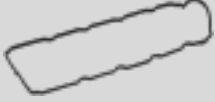





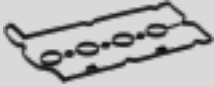









FIAT 				
<p>138 C.000 146 B2.000 149 B2.000 149 B3.000 149 B4.000/046</p> <p>4 Cyl. 1698 ccm Cyl. 82,6 Ø</p> <p>Duna 01/1987 → 10/2001</p> <p>Elba 04/1989 → 10/1997</p> <p>Fiorino 01/1988 → 05/2000</p> <p>Penny 01/1986 → 12/1990</p> <p>Regata 01/1984 → 12/1989</p> <p>Ritmo 05/1985 → 12/1987</p> <p>Tipo 01/1988 → 10/1995</p> <p>Uno 07/1986 → 08/2000</p>	<p>S⊕* 143.041 5890694 +40004940 +40004300 +40004260</p>  <p>ES⊕ 143.031 5890695 +40004940</p> 	<p>724.760 46431639 1,65 mm $\frac{2}{3}$ 83,5 Ø </p> <p>724.770 46431640 1,75 mm $\frac{2}{3}$ 83,5 Ø </p> <p>724.780 46431641 1,85 mm $\frac{2}{3}$ 83,5 Ø </p> <p>724.790 46431642 1,95 mm $\frac{2}{3}$ 83,5 Ø </p> <p>986.373 46451593 1,65 mm $\frac{2}{3}$ 83 Ø </p> <p>986.381 46451594 1,75 mm $\frac{2}{3}$ 83 Ø </p> <p>773.990 46451595 1,85 mm $\frac{2}{3}$ 83 Ø </p> <p>986.390 46451596 1,95 mm $\frac{2}{3}$ 83 Ø </p> <p>1 ▽ 2 ▽ 3 ▽</p>	<p>ZKS 760.510 7653650 (10x) M 12x1,25x134</p> 	<p>480.980 7702774</p> 
<p>146 D7.000 176 A3.000 176 A5.000 176 B3.000 176 B7.000 178 C9.066</p> <p>4 Cyl. 1698 ccm Cyl. 82,6 Ø</p> <p>Fiorino TD 11/1996 → 08/2006</p> <p>Palio 04/1996 → 09/2002</p> <p>Palio TD 04/1996 →</p> <p>Punto 04/1994 → 02/2000</p> <p>Punto TD 01/1994 → 02/2000</p> <p>Siena 05/1999 → 12/2009</p> <p>Siena TD 02/2006 → 12/2009</p> <p>Strada TD 06/1999 → 01/2010</p>	<p>ES⊕ 530.080 5892423 +40004940</p> 	<p>724.760 46431639 1,65 mm $\frac{2}{3}$ 83,5 Ø </p> <p>724.770 46431640 1,75 mm $\frac{2}{3}$ 83,5 Ø </p> <p>724.780 46431641 1,85 mm $\frac{2}{3}$ 83,5 Ø </p> <p>724.790 46431642 1,95 mm $\frac{2}{3}$ 83,5 Ø </p> <p>986.373 46451593 1,65 mm $\frac{2}{3}$ 83 Ø </p> <p>986.381 46451594 1,75 mm $\frac{2}{3}$ 83 Ø </p> <p>773.990 46451595 1,85 mm $\frac{2}{3}$ 83 Ø </p> <p>986.390 46451596 1,95 mm $\frac{2}{3}$ 83 Ø </p> <p>1 ▽ 2 ▽ 3 ▽</p>	<p>ZKS 760.510 7653650 (10x) M 12x1,25x134</p> 	<p>480.980 7702774</p> 

			<p>a) </p> <p>b) </p>	<p>K: </p> <p>N: </p>	
<p>VAS 294.250 FPM 294.110 7553637 FPM 8x</p>	<p>⇒</p>	<p>480.990 46462772</p> 	<p>a) 671.100 5959226 →12/1989</p>  <p>a) 480.960 7647596 01/1990→</p>  <p>b) 587.100 7734022 M 22x1,5x13</p>	<p>K:← 440.730 40004260 AW/BS RD ACM 30x43x8</p> <p>K:→ 440.830 40004300 AW/BS LD FPM 74x90x10</p> <p>N:← 440.750 40004940 AW/BS RD FPM 30x52x7</p>	
<p>VAS 294.250 FPM 294.110 7553637 FPM 8x</p>	<p>⇒</p>	<p>480.990 46462772</p> 	<p>a) 480.960 7647596</p>  <p>b) 587.100 7734022 M 22x1,5x13</p>	<p>K:← 440.730 40004260 AW/BS RD ACM 30x43x8</p> <p>K:→ 440.830 40004300 AW/BS LD FPM 74x90x10</p> <p>N:← 440.750 40004940 AW/BS RD FPM 30x52x7</p>	

<p>FIAT</p> 				
<p>182 A2.000 4 Cyl. 1747 ccm Cyl. 82,0 Ø</p> <p>Brava 10/1995 → 08/2001</p> <p>Bravo 10/1995 → 10/2001</p> <p>Marea 09/1996 → 05/2002</p>	<p>S⊕* 710.421 →06/1999</p> <p>ES⊕ 710.431 →06/1999</p> <p>ES⊕ 180.560 71714940 07/1999→</p> <p>CS* 431.250 71719779</p>	<p>710.440 60608894</p> <p>83 Ø </p>	<p>ZKS 152.080 7710582 (10x) M 10x1,25x254</p> 	<p>ZKHS 199.090 60586217</p> 
<p>183 A1.000 4 Cyl. 1747 ccm Cyl. 82,0 Ø</p> <p>Barchetta 04/1995 → 05/2005</p> <p>Brava 02/2000 → 06/2003</p> <p>Coupé 03/1996 → 08/2000</p> <p>Marea 09/1996 → 12/2007</p> <p>Punto 09/1999 → 03/2012</p>	<p>S⊕* 710.421</p> <p>ES⊕ 710.431</p> <p>CS* 431.250 71719779</p>	<p>710.440 60608894</p> <p>83 Ø </p>	<p>ZKS 152.080 7710582 (10x) M 10x1,25x254</p> 	<p>ZKHS 199.090 60586217</p> 
<p>188 A6.000 192 A4.000 4 Cyl. 1747 ccm Cyl. 82,0 Ø</p> <p>Barchetta 04/1995 → 05/2005</p> <p>Punto 09/1999 → 03/2012</p> <p>Stilo 10/2001 → 08/2008</p>	<p>S⊕* 180.610 71717901</p> <p>ES⊕ 180.620 71717900</p> <p>CS* 431.250 71719779</p>	<p>626.727 60664642 0,49 mm ±</p> <p>84 Ø </p>	<p>ZKS 152.080 7710582 (10x) M 10x1,25x254</p> 	<p>ZKHS 199.090 60586217</p> 

			<p>a) </p> <p>b) </p>	<p>K: </p> <p>N: </p>	
<p>VAS 825.042 FPM 2x 701.289 46436047 FPM 16x</p>	<p>448.510 73502761</p> 	<p>AAS 375.140 60664260 07/1999→ Mot. 4873621→</p> <p>685.150 60659952 →07/1999 →Mot. 4873620</p> 	<p>a) 030.793 Dirko HT</p> <p>b) 877.920 incl. 339.580 46476967 M 18x1,5x22</p> <p>b) 339.580 55196309 CU A 18x26x1,5</p>	<p>K:← 069.590 7628850 AW/BS RD FPM 31x41x7</p> <p>K:→ 199.191 71718365 SP LD FPM 93x12</p> <p>N:← 477.010 60603436 AW/BS RD FPM 55x68x8</p> <p>N:← 505.838 60809849 ASW RD FPM 30x42x7</p>	
<p>VAS 825.042 FPM 2x 701.289 46436047 FPM 16x</p>	<p>448.510 73502761</p> 	<p>685.150 60659952</p> 	<p>a) 030.793 Dirko HT</p> <p>b) 877.920 incl. 339.580 46476967 M 18x1,5x22</p> <p>b) 339.580 55196309 CU A 18x26x1,5</p>	<p>K:← 069.590 7628850 AW/BS RD FPM 31x41x7</p> <p>K:→ 199.191 71718365 SP LD FPM 93x12</p> <p>N:← 477.010 60603436 AW/BS RD FPM 55x68x8</p> <p>N:← 505.838 60809849 ASW RD FPM 30x42x7</p>	
<p>VAS 825.042 FPM 2x 701.289 46436047 FPM 16x</p>	<p>448.510 73502761</p> 	<p>685.150 60659952</p> 	<p>a) 030.793 Dirko HT</p> <p>b) 877.920 incl. 339.580 46476967 M 18x1,5x22</p> <p>b) 339.580 55196309 CU A 18x26x1,5</p>	<p>K:← 069.590 7628850 AW/BS RD FPM 31x41x7</p> <p>K:→ 199.191 71718365 SP LD FPM 93x12</p> <p>N:← 477.010 60603436 AW/BS RD FPM 55x68x8</p> <p>N:← 505.838 60809849 ASW RD FPM 30x42x7</p>	

<p>FIAT</p> 				
<p>370 A0.011</p> <p>4 Cyl. 1747 ccm Cyl. 80,5 Ø</p> <p>Argo 03/2017 →</p> <p>Bravo 12/2010 →</p> <p>Cronos 12/2017 →</p> <p>Doblo 08/2010 →</p> <p>Grande Punto 07/2010 → 07/2012</p> <p>Idea 08/2010 → 12/2016</p> <p>Linea 01/2009 →</p> <p>Palio 06/2012 → 12/2016</p> <p>Punto 07/2010 →</p> <p>Strada 08/2010 → 01/2021</p> <p>Toro 01/2016 →</p>	<p>CS* 903.590</p>		<p>ZKS 949.360 55223509 (10x) M 10x1,5x148</p>	<p>ZKHS 763.880 518.030 55247838</p> 
<p>LFW (XU7JP)</p> <p>4 Cyl. 1761 ccm Cyl. 83,0 Ø</p> <p>Ulysse 05/1997 → 08/2002</p>	<p>CS* 984.427</p>	<p>563.147 9613314680 1,27 mm $\frac{1}{2}$ 84,5 Ø</p>  <p>436.651 1,48 mm $\frac{1}{2}$ 84,5 Ø</p> 	<p>ZKS 758.290 9600597780 (10x) M 11x1,5x168</p> 	<p>590.932 9400249489</p> 
<p>939 A4.000</p> <p>4 Cyl. 1796 ccm Cyl. 80,5 Ø</p> <p>Croma 12/2005 →</p>	<p>ES⊕ 354.010 CS* 353.830 OKS 599.160</p> 	<p>076.892 71744395 0,65 mm $\frac{1}{2}$ 81,7 Ø</p> 		<p>354.030 55354237</p> 

			<p>a) </p> <p>b) </p>	<p>K: </p> <p>N: </p>	
<p>VAS 708.100 FPM 026.650 55263053 FPM 16x</p> 	<p>571.770 55224457</p>	<p>939.340 7090012 55263732 4x</p> 	<p>a) 485.960 55226126</p>  <p>b) 012.001 9659107280 M 14x1,5x20</p> <p>b) 176.090 13x22,4x3</p>	<p>K:← 583.050 7089564 AS RD FPM 32x45x6</p> <p>K:→ 902.760 55223567 A/BS LD FPM 91x111x9</p>	
<p>VAS 294.250 FPM 294.110 7553637 FPM 8x</p>	<p>160.720</p> 	<p>023.540 2x</p>  <p>023.680 5894954 2x</p> 	<p>a) 590.984</p>  <p>b) 877.950 incl. 813.036 M 14x1,25x13</p> <p>b) 813.036 9400313279 CU C 14x20x2</p>	<p>K:← 508.233 9614194980 ASW RD FPM/ACM 42x62x7</p> <p>K:→ 508.209 9614379380 ASW LD FPM/ACM 90x110x7</p> <p>N:← 505.366 9653528780 9400236499 ASW RD FPM/ACM 36x50x7</p>	
<p>061.760 71739773 FPM 16x</p>	<p>355.340 71744380</p> 	<p>AAS 207.210</p>  <p>434.350 71744413</p> 	<p>a) 030.793 Dirko HT</p> <p>b) 476.750 FPM RD 18x22x2</p>	<p>K:← 056.900 71739825 A/BS RD FPM 31,5x42x7</p> <p>K:→ 353.840 55555805 SP LD PTFE/ACM 80x98</p> <p>N:← 353.990 55563374 ASW RD FPM 35x48x7 2x</p>	

FIAT

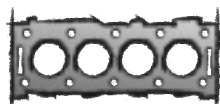
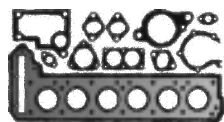

WJY (DW8)/(DW8B)
WJZ (DW8)

4 Cyl. 1868 ccm
Cyl. 82,2 Ø

Scudo

04/1998 → 12/2006

S⊕* 718.610

S⊕* 896.710



ES⊕ 219.230



CS* 851.292

130.642

9624851880

0,510 mm



→ 0,550 mm

1,26 mm $\frac{+}{-}$ 84 Ø

1 ⊗

130.652

9624851980

0,550 mm



→ 0,590 mm

1,30 mm $\frac{+}{-}$ 84 Ø

2 ⊗

130.662

9624852080

0,590 mm



→ 0,630 mm

1,34 mm $\frac{+}{-}$ 84 Ø

3 ⊗

130.672

9624852180

0,630 mm



→ 0,670 mm

1,38 mm $\frac{+}{-}$ 84 Ø

4 ⊗

130.682

9624852280

0,670 mm



→ 0,710 mm

1,42 mm $\frac{+}{-}$ 84 Ø

5 ⊗

130.692

9624851980

1,46 mm $\frac{+}{-}$ 84 Ø

2 ⊗

130.712

1,50 mm $\frac{+}{-}$ 84 Ø

1 ⊗

130.722

1,54 mm $\frac{+}{-}$ 84 Ø

2 ⊗

130.732

1,58 mm $\frac{+}{-}$ 84 Ø

3 ⊗

130.742

1,62 mm $\frac{+}{-}$ 84 Ø

4 ⊗

ZKS 152.550

9633190080 (10x)

M 12x1,5x123



773.650

9400249959

↑











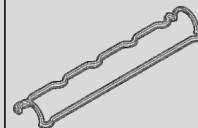



773.660

9400249979

↓

→11/1999



			<p>a) </p> <p>b) </p>	<p>K: </p> <p>N: </p>	
<p>VAS 294.250 FPM 294.110 7553637 FPM 8x</p>	<p>773.730 9569758180 2x</p> 	<p>773.800 9569757880 2x</p>  <p>773.810 9569757780</p> 	<p>a) 590.984</p>  <p>b) 877.930 incl. 108.502 M 10x1,25x13</p> <p>b) 877.950 incl. 813.036 M 14x1,25x13</p> <p>b) 108.502 9400313409 CU A 10x21x2,1</p> <p>b) 813.036 9400313279 CU C 14x20x2</p>	<p>K:← 508.233 9614194980 ASW RD FPM/ACM 42x62x7</p> <p>K:→ 508.209 9614379380 ASW LD FPM/ACM 90x110x7</p> <p>N:← 302.589 9400236149 A WD FPM 35x50x8</p>	

FIAT

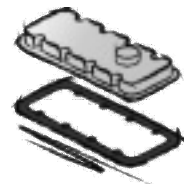
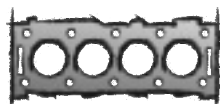
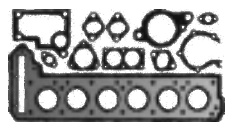

D8B
D8B (XUD9TE)
DHX
DHX (XUD9TE)
DHX (XUD9TF/L)

4 Cyl. 1905 ccm
 Cyl. 83,0 Ø

Ducato
 05/1998 → 11/2001
Ducato TD
 04/1998 → 04/2002
Scudo TD
 02/1996 → 12/2006
Ulysse TD
 02/1995 → 08/2002

S⊕* **581.128**



ES⊕ **116.580**



CS* **984.817**

147.522

9621917180



0,670 mm

1,34 mm $\frac{\pm}{\pm}$ 84 Ø
 1 ▽

147.532

9621917280



0,670 mm

0,710 mm

1,39 mm $\frac{\pm}{\pm}$ 84 Ø
 2 ▽

147.542

9621917380



0,710 mm

0,750 mm

1,44 mm $\frac{\pm}{\pm}$ 84 Ø
 3 ▽

147.552

9621917480

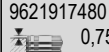

0,750 mm

0,790 mm

1,49 mm $\frac{\pm}{\pm}$ 84 Ø
 4 ▽

147.562

9621917580

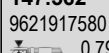

0,790 mm

0,830 mm

1,54 mm $\frac{\pm}{\pm}$ 84 Ø
 5 ▽

422.511

9628139180

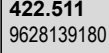

1,59 mm $\frac{\pm}{\pm}$ 84 Ø

2 ▽

ZKS **582.630**











M 12x1,5x148











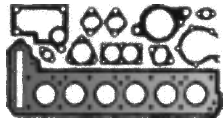
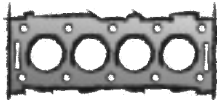

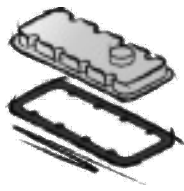







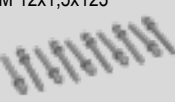
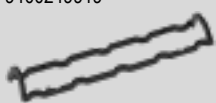

581.305











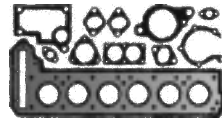
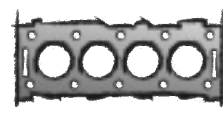

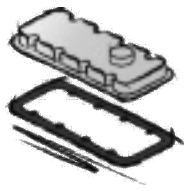



9400249919



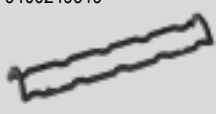





















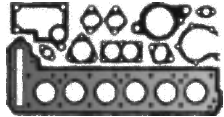
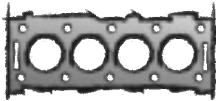

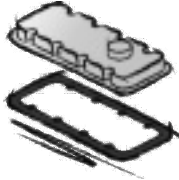













			<p>a) </p> <p>b) </p>	<p>K: </p> <p>N: </p>	
<p>VAS 294.250 FPM</p> <p>294.110 7553637 FPM 8x</p>	<p>⇒</p>	<p>919.829 9567224080</p> 	<p>a) 590.984</p>  <p>b) 877.950 incl. 813.036 M 14x1,25x13</p> <p>b) 813.036 9400313279 CU C 14x20x2</p>	<p>K:← 508.233 9614194980 ASW RD FPM/ACM 42x62x7</p> <p>K:→ 508.209 9614379380 ASW LD FPM/ACM 90x110x7</p> <p>N:← 302.589 9400236149 A WD FPM 35x50x8</p>	<p>TLS 453.800</p> 

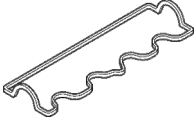
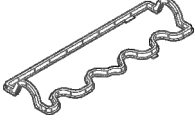







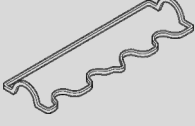
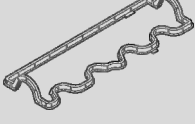







<p>FIAT</p> 				
<p>D9B DJY</p> <p>4 Cyl. 1905 ccm Cyl. 83,0 Ø</p> <p>Ducato 04/1998 → 04/2002</p> <p>Scudo 02/1996 → 12/2006</p>	<p>S⊕* 581.128</p>  <p>ES⊕ 116.580</p>  <p>CS* 984.817</p>	<p>059.031 9623068080</p>  <p>→ 0,670 mm</p> <p>1,36 mm $\frac{\pm}{\text{mm}}$ 84 Ø</p> <p>1 ∇</p> <p>059.041 9623068180</p>  <p>→ 0,670 mm</p> <p>→ 0,710 mm</p> <p>1,40 mm $\frac{\pm}{\text{mm}}$ 84 Ø</p> <p>2 ∇</p> <p>059.171 9623068280</p>  <p>→ 0,710 mm</p> <p>→ 0,750 mm</p> <p>1,44 mm $\frac{\pm}{\text{mm}}$ 84 Ø</p> <p>3 ∇</p> <p>059.201 9623068380</p>  <p>→ 0,750 mm</p> <p>→ 0,790 mm</p> <p>1,48 mm $\frac{\pm}{\text{mm}}$ 84 Ø</p> <p>4 ∇</p> <p>059.341 9623068480</p>  <p>→ 0,790 mm</p> <p>→ 0,830 mm</p> <p>1,52 mm $\frac{\pm}{\text{mm}}$ 84 Ø</p> <p>5 ∇</p>	<p>ZKS 152.550 9633190080 (10x) M 12x1,5x123</p> 	<p>581.305 9400249919</p> 



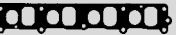

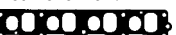





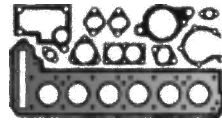
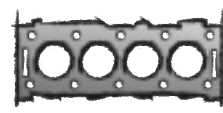

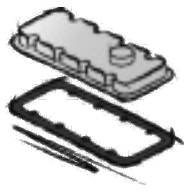









			<p>a) </p> <p>b) </p>	<p>K: </p> <p>N: </p>	
<p>VAS 294.250 FPM</p> <p>294.110 7553637 FPM 8x</p>	<p>420.451 2x</p> 		<p>a) 590.984</p>  <p>b) 877.950 incl. 813.036 M 14x1,25x13</p> <p>b) 813.036 9400313279 CU C 14x20x2</p>	<p>K:← 508.233 9614194980 ASW RD FPM/ACM 42x62x7</p> <p>K:→ 508.209 9614379380 ASW LD FPM/ACM 90x110x7</p> <p>N:← 302.589 9400236149 A WD FPM 35x50x8</p>	

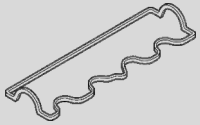
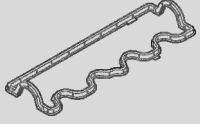



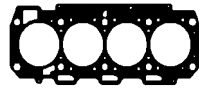



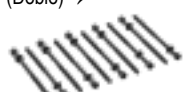
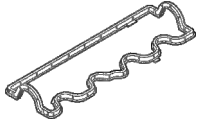



<p>FIAT</p> 				
<p>D9B (XUD9A) DJY (XUD9)</p> <p>4 Cyl. 1905 ccm Cyl. 83,0 Ø</p> <p>Ducato 04/1998 → 04/2002</p>	<p>S⊕* 581.128 </p> <p>ES⊕ 116.580 </p> <p>CS* 984.817</p>	<p>059.031 9623068080  → 0,670 mm 1,36 mm $\frac{\pm}{\pm}$ 84 Ø 1 ▽</p> <p>059.041 9623068180  → 0,670 mm → 0,710 mm 1,40 mm $\frac{\pm}{\pm}$ 84 Ø 2 ▽</p> <p>059.171 9623068280  → 0,710 mm → 0,750 mm 1,44 mm $\frac{\pm}{\pm}$ 84 Ø 3 ▽</p> <p>059.201 9623068380  → 0,750 mm → 0,790 mm 1,48 mm $\frac{\pm}{\pm}$ 84 Ø 4 ▽</p> <p>059.341 9623068480  → 0,790 mm → 0,830 mm 1,52 mm $\frac{\pm}{\pm}$ 84 Ø 5 ▽</p>	<p>ZKS 152.550 9633190080 (10x) M 12x1,5x123</p> 	<p>581.305 9400249919</p> 
<p>182 A7.000 182 A8.000</p> <p>4 Cyl. 1910 ccm Cyl. 82,0 Ø</p> <p>Brava TD 03/1996 → 10/2001</p> <p>Bravo TD 03/1996 → 10/2001</p> <p>Marea TD 05/1996 → 06/2003</p>	<p>ES⊕ 102.260 71711144 +40004400 (2x)</p> 	<p>186.231 ● 46473174 1,60 mm $\frac{\pm}{\pm}$ 83 Ø </p> <p>186.381 ● 46473175 1,70 mm $\frac{\pm}{\pm}$ 83 Ø </p> <p>186.421 ● 46473176 1,80 mm $\frac{\pm}{\pm}$ 83 Ø </p>	<p>ZKS 152.440 7775920 (10x) M 12x1,25x218</p> 	<p>375.090 7737607</p> 











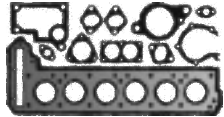
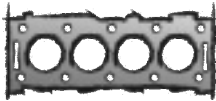

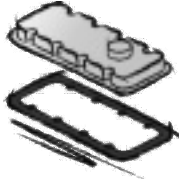





















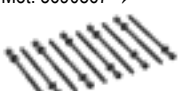
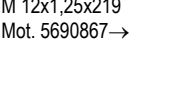
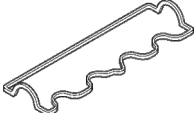



			<p>a) </p> <p>b) </p>	<p>K: </p> <p>N: </p>	
<p>VAS 294.250 FPM</p> <p>294.110 7553637 FPM 8x</p>	<p>420.451 2x</p> 		<p>a) 590.984</p>  <p>b) 813.052 CU C 16x22x2</p>	<p>K:← 508.233 9614194980 ASW RD FPM/ACM 42x62x7</p> <p>K:→ 508.209 9614379380 ASW LD FPM/ACM 90x110x7</p> <p>N:← 302.589 9400236149 A WD FPM 35x50x8</p>	
<p>VAS 294.250 FPM</p> <p>294.110 7553637 FPM 8x</p>	<p>458.360 46467747</p> 	<p>655.380 46461755</p> 	<p>a) 030.793 Dirko HT</p> <p>b) 877.920 incl. 339.580 46476967 M 18x1,5x22</p> <p>b) 339.580 55196309 CU A 18x26x1,5</p>	<p>K:← 069.590 7628850 AW/BS RD FPM 31x41x7</p> <p>K:→ 199.191 71718365 SP LD FPM 93x12</p> <p>N:← 505.838 60809849 ASW RD FPM 30x42x7</p>	







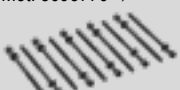
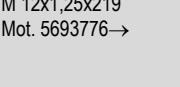
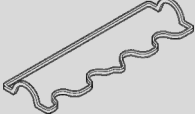











<p>FIAT</p> 				
<p>182 B4.000</p> <p>4 Cyl. 1910 ccm Cyl. 82,0 Ø</p> <p>Brava JTD 12/1998 → 10/2001</p> <p>Bravo JTD 12/1998 → 10/2001</p> <p>Marea JTD 12/1998 → 12/2007</p> <p>Multipla JTD 04/1999 → 06/2010</p>	<p>S⊕* 074.660 71717833</p>  <p>ES⊕ 074.670 71717834</p> 	<p>186.532 ● 60814599</p>  <p>0,750 mm → 0,880 mm 1,60 mm $\frac{\pm}{\pm}$ 83 Ø</p> <p>186.542 ● 60814600</p>  <p>0,890 mm → 0,970 mm 1,70 mm $\frac{\pm}{\pm}$ 83 Ø 1 ⊗</p> <p>186.552 ● 60814601</p>  <p>0,980 mm → 1,062 mm 1,80 mm $\frac{\pm}{\pm}$ 83 Ø 2 ⊗</p>	<p>ZKS 152.440 7775920 (10x) M 12x1,25x218</p> 	<p>199.160 46432087</p> 
<p>182 B9.000</p> <p>4 Cyl. 1910 ccm Cyl. 82,0 Ø</p> <p>Brava JTD 09/2000 → 10/2001</p> <p>Bravo JTD 09/2000 → 10/2001</p> <p>Doblo JTD 10/2001 →</p> <p>Marea JTD 01/2001 → 12/2007</p> <p>Marea TD 09/1996 → 06/2003</p>	<p>S⊕* 180.000 71718129 +60814607 →Mot. 4081110</p>  <p>ES⊕ 180.060 71718658 →Mot. 4081110</p>  <p>ES⊕ 498.980 71739971 Mot. 4081111→</p>  <p>CS 387.580 71730404</p>	<p>217.001 55200891</p>  <p>0,020 mm → 0,100 mm 0,82 mm $\frac{\pm}{\pm}$ 83 Ø</p> <p>217.021 55202010</p>  <p>0,101 mm → 0,200 mm 0,92 mm $\frac{\pm}{\pm}$ 83 Ø 1 ⊗</p> <p>217.031 55202011</p>  <p>0,201 mm → 0,295 mm 1,02 mm $\frac{\pm}{\pm}$ 83 Ø 2 ⊗</p>	<p>ZKS 152.440 7775920 (10x) M 12x1,25x218 →Mot. 5689123</p>  <p>ZKS 642.100 M 12x1,25x224,5 Doblo (119/223) Mot. 5689124→</p>  <p>ZKS 687.330 55 214 216 (10x) M 12x1,25x219 Mot. 5689124→</p>	<p>199.030 46552748 →Mot. 4081110</p>  <p>430.400 55197598 Mot. 4081111→</p> 
<p>186 A6.000</p> <p>4 Cyl. 1910 ccm Cyl. 82,0 Ø</p> <p>Marea JTD 09/2000 → 08/2002</p> <p>Multipla JTD 09/2000 → 07/2002</p>	<p>S⊕* 180.000 71718129 +60814607 →Mot. 4081110</p>  <p>ES⊕ 180.060 71718658 →Mot. 4081110</p>  <p>ES⊕ 498.980 71739971 Mot. 4081111→</p>  <p>CS 387.580 71730404</p>	<p>217.001 55200891</p>  <p>0,020 mm → 0,100 mm 0,82 mm $\frac{\pm}{\pm}$ 83 Ø</p> <p>217.021 55202010</p>  <p>0,101 mm → 0,200 mm 0,92 mm $\frac{\pm}{\pm}$ 83 Ø 1 ⊗</p> <p>217.031 55202011</p>  <p>0,201 mm → 0,295 mm 1,02 mm $\frac{\pm}{\pm}$ 83 Ø 2 ⊗</p>	<p>ZKS 152.440 7775920 (10x) M 12x1,25x218</p> 	<p>199.030 46552748 →Mot. 4081110</p>  <p>430.400 55197598 Mot. 4081111→</p> 











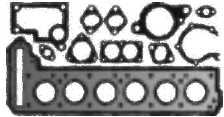
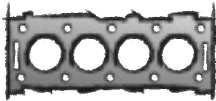

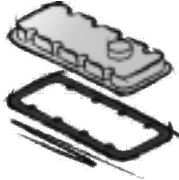







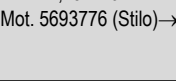
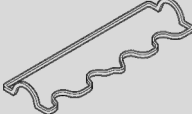



			<p>a) </p> <p>b) </p>	<p>K: </p> <p>N: </p>	
<p>VAS 294.250 FPM 294.110 7553637 FPM 8x</p>	<p>458.360 46467747 </p>	<p>290.790 46437440 →Mot. 1815272  879.280 71738458 Mot. 1815273→ </p>	<p>a) 030.793 Dirko HT b) 877.920 incl. 339.580 46476967 M 18x1,5x22 b) 339.580 55196309 CU A 18x26x1,5</p>	<p>K:← 069.590 7628850 AW/BS RD FPM 31x41x7 K:→ 199.191 71718365 SP LD FPM 93x12 N:← 505.838 60809849 ASW RD FPM 30x42x7</p>	
<p>VAS 294.250 FPM 294.110 7553637 FPM 8x</p>	<p>458.360 46467747 </p>	<p>290.790 46437440 →Mot. 1815272  879.280 71738458 Mot. 1815273→ </p>	<p>a) 030.793 Dirko HT b) 877.920 incl. 339.580 46476967 M 18x1,5x22 b) 339.580 55196309 CU A 18x26x1,5</p>	<p>K:← 069.590 7628850 AW/BS RD FPM 31x41x7 K:→ 199.191 71718365 SP LD FPM 93x12 N:← 505.838 60809849 ASW RD FPM 30x42x7</p>	<p>TLS 434.310 </p>
<p>VAS 294.250 FPM 294.110 7553637 FPM 8x</p>	<p>458.360 46467747 </p>	<p>879.280 71738458 </p>	<p>a) 030.793 Dirko HT b) 877.920 incl. 339.580 46476967 M 18x1,5x22 b) 339.580 55196309 CU A 18x26x1,5</p>	<p>K:← 069.590 7628850 AW/BS RD FPM 31x41x7 K:→ 199.191 71718365 SP LD FPM 93x12 N:← 505.838 60809849 ASW RD FPM 30x42x7</p>	<p>TLS 434.420 </p>

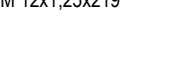
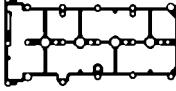





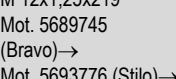

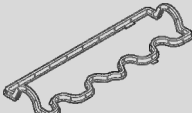





<p>FIAT</p> 				
<p>186 A8.000 4 Cyl. 1910 ccm Cyl. 82,0 Ø</p> <p>Multipla JTD 07/2002 → 06/2010</p>	<p>S⊕* 180.000 71718129 +60814607 →Mot. 4081110</p>  <p>ES⊕ 180.060 71718658 →Mot. 4081110</p>  <p>ES⊕ 498.980 71739971 Mot. 4081111→</p>  <p>CS 387.580 71730404</p>	<p>217.001 55200891</p>  <p> 0,020 mm → 0,100 mm 0,82 mm $\frac{3}{4}$ 83 Ø</p> <p>217.021 55202010</p>  <p> 0,101 mm → 0,200 mm 0,92 mm $\frac{3}{4}$ 83 Ø 1 ⊗</p> <p>217.031 55202011</p>  <p> 0,201 mm → 0,295 mm 1,02 mm $\frac{3}{4}$ 83 Ø 2 ⊗</p>	<p>ZKS 152.440 7775920 (10x) M 12x1,25x218 →Mot. 5703384 (Multipla)</p>  <p>ZKS 642.100 M 12x1,25x224,5 Mot. 5703385 (Multipla)→</p>  <p>ZKS 687.330 55 214 216 (10x) M 12x1,25x219 Mot. 5703385 (Multipla)→</p>	<p>199.030 46552748 →Mot. 4081110</p>  <p>430.400 55197598 Mot. 4081111→</p> 
<p>186 A9.000 4 Cyl. 1910 ccm Cyl. 82,0 Ø</p> <p>Doblo Multijet 10/2005 →</p> <p>Multipla JTD 04/2002 → 06/2010</p>	<p>ES⊕ 498.980 71739971</p>  <p>CS 387.580 71730404</p>	<p>217.001 55200891</p>  <p> 0,020 mm → 0,100 mm 0,82 mm $\frac{3}{4}$ 83 Ø</p> <p>217.021 55202010</p>  <p> 0,101 mm → 0,200 mm 0,92 mm $\frac{3}{4}$ 83 Ø 1 ⊗</p> <p>217.031 55202011</p>  <p> 0,201 mm → 0,295 mm 1,02 mm $\frac{3}{4}$ 83 Ø 2 ⊗</p>	<p>ZKS 152.440 7775920 (10x) M 12x1,25x218 →Mot. 5703384 (Multipla) →Mot. 5689123 (Doblo)</p>  <p>ZKS 687.330 55 214 216 (10x) M 12x1,25x219 Mot. 5689124 (Doblo)→ Mot. 5703385 (Multipla)→</p> <p>ZKS 642.100 M 12x1,25x224,5 Mot. 5703385 (Multipla)→ Mot. 5689124 (Doblo)→</p> 	<p>430.400 55197598</p> 









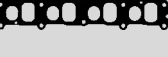

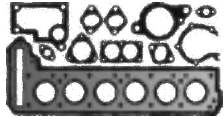
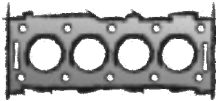

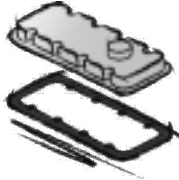





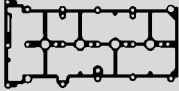



			<p>a) </p> <p>b) </p>	<p>K: </p> <p>N: </p>	
<p>VAS 294.250 FPM 294.110 7553637 FPM 8x</p>	<p>458.360 46467747 </p>	<p>879.280 71738458 </p>	<p>a) 030.793 Dirko HT</p> <p>b) 877.920 incl. 339.580 46476967 M 18x1,5x22</p> <p>b) 339.580 55196309 CU A 18x26x1,5</p>	<p>K:← 069.590 7628850 AW/BS RD FPM 31x41x7</p> <p>K:→ 199.191 71718365 SP LD FPM 93x12</p> <p>N:← 505.838 60809849 ASW RD FPM 30x42x7</p>	<p>TLS 434.420 </p>
<p>VAS 294.250 FPM 294.110 7553637 FPM 8x</p>	<p>458.360 46467747 </p>	<p>879.280 71738458 </p>	<p>a) 030.793 Dirko HT</p> <p>b) 877.920 incl. 339.580 46476967 M 18x1,5x22</p> <p>b) 339.580 55196309 CU A 18x26x1,5</p>	<p>K:← 069.590 7628850 AW/BS RD FPM 31x41x7</p> <p>K:→ 199.191 71718365 SP LD FPM 93x12</p> <p>N:← 505.838 60809849 ASW RD FPM 30x42x7</p>	

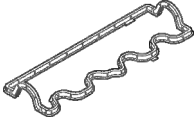







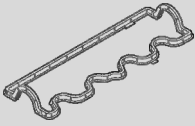



<p>FIAT</p> 				
<p>188 A2.000 188 A7.000</p> <p>4 Cyl. 1910 ccm Cyl. 82,0 Ø</p> <p>Palio JTD 09/2001 →</p> <p>Punto JTD 09/1999 → 03/2012</p> <p>Strada JTD 04/2003 →</p>	<p>S⊕* 180.000 71718129 +60814607 →Mot. 4081110</p>  <p>ES⊕ 180.060 71718658 →Mot. 4081110</p>  <p>ES⊕ 498.980 71739971 Mot. 4081111→</p>  <p>CS 387.580 71730404</p>	<p>217.001 55200891</p>  <p> 0,020 mm → 0,100 mm</p> <p>0,82 mm $\frac{+}{-}$ 83 Ø</p> <p>217.021 55202010</p>  <p> 0,101 mm → 0,200 mm</p> <p>0,92 mm $\frac{+}{-}$ 83 Ø 1 ⊗</p> <p>217.031 55202011</p>  <p> 0,201 mm → 0,295 mm</p> <p>1,02 mm $\frac{+}{-}$ 83 Ø 2 ⊗</p>	<p>ZKS 152.440 7775920 (10x) M 12x1,25x218</p> 	<p>199.030 46552748 →Mot. 4081110</p>  <p>430.400 55197598 Mot. 4081111→</p> 
<p>188 B2.000</p> <p>4 Cyl. 1910 ccm Cyl. 82,0 Ø</p> <p>Idea Multijet 01/2004 →</p> <p>Punto JTD 06/2003 → 03/2012</p>	<p>S⊕* 180.000 71718129 +60814607 →Mot. 4081110</p>  <p>ES⊕ 180.060 71718658 →Mot. 4081110</p>  <p>ES⊕ 498.980 71739971 Mot. 4081111→</p>  <p>CS 387.580 71730404</p>	<p>217.001 55200891</p>  <p> 0,020 mm → 0,100 mm</p> <p>0,82 mm $\frac{+}{-}$ 83 Ø</p> <p>217.021 55202010</p>  <p> 0,101 mm → 0,200 mm</p> <p>0,92 mm $\frac{+}{-}$ 83 Ø 1 ⊗</p> <p>217.031 55202011</p>  <p> 0,201 mm → 0,295 mm</p> <p>1,02 mm $\frac{+}{-}$ 83 Ø 2 ⊗</p>	<p>ZKS 152.440 7775920 (10x) M 12x1,25x218 →Mot. 5690866</p>  <p>ZKS 642.100 M 12x1,25x224,5 Mot. 5690867→</p>  <p>ZKS 687.330 55 214 216 (10x) M 12x1,25x219 Mot. 5690867→</p> 	<p>199.030 46552748 →Mot. 4081110</p>  <p>430.400 55197598 Mot. 4081111→</p> 
<p>192 A1.000</p> <p>4 Cyl. 1910 ccm Cyl. 82,0 Ø</p> <p>Bravo Multijet 11/2006 → 12/2009</p> <p>Stilo JTD 10/2001 → 08/2008</p>	<p>S⊕* 180.000 71718129 +60814607 →Mot. 4081110</p>  <p>ES⊕ 180.060 71718658 →Mot. 4081110</p>  <p>ES⊕ 498.980 71739971 Mot. 4081111→</p>  <p>CS 387.580 71730404</p>	<p>217.001 55200891</p>  <p> 0,020 mm → 0,100 mm</p> <p>0,82 mm $\frac{+}{-}$ 83 Ø</p> <p>217.021 55202010</p>  <p> 0,101 mm → 0,200 mm</p> <p>0,92 mm $\frac{+}{-}$ 83 Ø 1 ⊗</p> <p>217.031 55202011</p>  <p> 0,201 mm → 0,295 mm</p> <p>1,02 mm $\frac{+}{-}$ 83 Ø 2 ⊗</p>	<p>ZKS 152.440 7775920 (10x) M 12x1,25x218 →Mot. 5693775</p>  <p>ZKS 642.100 M 12x1,25x224,5 Mot. 5693776→</p>  <p>ZKS 687.330 55 214 216 (10x) M 12x1,25x219 Mot. 5693776→</p> 	<p>199.030 46552748 →Mot. 4081110</p>  <p>430.400 55197598 Mot. 4081111→</p> 





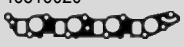



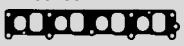

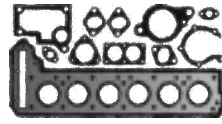
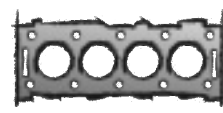

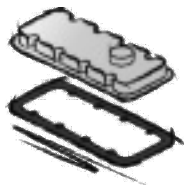





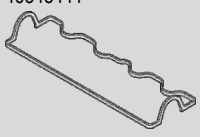

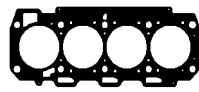



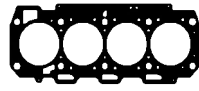

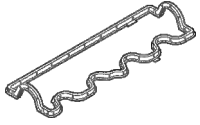
			<p>a) </p> <p>b) </p>	<p>K: </p> <p>N: </p>	
<p>VAS 294.250 FPM 294.110 7553637 FPM 8x</p>	<p>458.360 46467747 </p>	<p>290.790 46437440 →Mot. 1815272  879.280 71738458 Mot. 1815273→ </p>	<p>a) 030.793 Dirko HT</p> <p>b) 877.920 incl. 339.580 46476967 M 18x1,5x22</p> <p>b) 339.580 55196309 CU A 18x26x1,5</p>	<p>K:← 069.590 7628850 AW/BS RD FPM 31x41x7</p> <p>K:→ 199.191 71718365 SP LD FPM 93x12</p> <p>N:← 505.838 60809849 ASW RD FPM 30x42x7</p>	<p>TLS 434.310 </p>
<p>VAS 294.250 FPM 294.110 7553637 FPM 8x</p>	<p>458.360 46467747 </p>	<p>879.280 71738458 </p>	<p>a) 030.793 Dirko HT</p> <p>b) 877.920 incl. 339.580 46476967 M 18x1,5x22</p> <p>b) 339.580 55196309 CU A 18x26x1,5</p>	<p>K:← 069.590 7628850 AW/BS RD FPM 31x41x7</p> <p>K:→ 199.191 71718365 SP LD FPM 93x12</p> <p>N:← 505.838 60809849 ASW RD FPM 30x42x7</p>	<p>TLS 434.310 </p>
<p>VAS 294.250 FPM 294.110 7553637 FPM 8x</p>	<p>458.360 46467747 </p>	<p>879.280 71738458 </p>	<p>a) 030.793 Dirko HT</p> <p>b) 877.920 incl. 339.580 46476967 M 18x1,5x22</p> <p>b) 339.580 55196309 CU A 18x26x1,5</p>	<p>K:← 069.590 7628850 AW/BS RD FPM 31x41x7</p> <p>K:→ 199.191 71718365 SP LD FPM 93x12</p> <p>N:← 505.838 60809849 ASW RD FPM 30x42x7</p>	<p>TLS 434.420 </p>









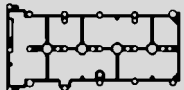





<p>FIAT</p> 				
<p>192 A3.000 192 A9.000</p> <p>4 Cyl. 1910 ccm Cyl. 82,0 Ø</p> <p>Stilo JTD 10/2001 → 08/2008</p> <p>Stilo Multijet 09/2005 → 08/2008</p>	<p>S⊕* 180.000 71718129 +60814607 →Mot. 4081110</p>  <p>ES⊕ 180.060 71718658 →Mot. 4081110</p>  <p>ES⊕ 498.980 71739971 Mot. 4081111→</p>  <p>CS 387.580 71730404</p>	<p>217.001 55200891</p>  <p>→ 0,020 mm → 0,100 mm</p> <p>0,82 mm ± 83 Ø</p> <p>217.021 55202010</p>  <p>→ 0,101 mm → 0,200 mm</p> <p>0,92 mm ± 83 Ø 1 ⊗</p> <p>217.031 55202011</p>  <p>→ 0,201 mm → 0,295 mm</p> <p>1,02 mm ± 83 Ø 2 ⊗</p>	<p>ZKS 152.440 7775920 (10x) M 12x1,25x218 →Mot. 5693775 (Stilo)</p>  <p>ZKS 642.100 M 12x1,25x224,5 Mot. 5693776 (Stilo)→</p>  <p>ZKS 687.330 55 214 216 (10x) M 12x1,25x219 Mot. 5693776 (Stilo)→</p> 	<p>199.030 46552748 →Mot. 4081110</p>  <p>430.400 55197598 Mot. 4081111→</p> 
<p>192 A5.000</p> <p>4 Cyl. 1910 ccm Cyl. 82,0 Ø</p> <p>Stilo JTD 09/2003 → 08/2008</p>	<p>ES⊕ 491.980 71730214</p>  <p>CS 387.580 71730404</p>	<p>217.052 55200890</p>  <p>→ 0,100 mm</p> <p>0,82 mm ± 83 Ø</p> <p>008.822 55201694</p>  <p>→ 0,101 mm → 0,200 mm</p> <p>0,92 mm ± 83 Ø 1 ⊗</p> <p>008.832 55201695</p>  <p>→ 0,201 mm → 0,295 mm</p> <p>1,02 mm ± 83 Ø 2 ⊗</p>	<p>ZKS 642.100 M 12x1,25x224,5</p>  <p>ZKS 687.330 55 214 216 (10x) M 12x1,25x219</p> 	<p>875.350 46814174</p> 
<p>192 A8.000 192 B5.000</p> <p>4 Cyl. 1910 ccm Cyl. 82,0 Ø</p> <p>Bravo Multijet 04/2007 → 12/2014</p> <p>Stilo JTD 09/2004 → 08/2008</p> <p>Stilo Multijet 09/2005 → 08/2008</p>	<p>ES⊕ 498.980 71739971</p>  <p>CS 387.580 71730404</p>	<p>217.001 55200891</p>  <p>→ 0,020 mm → 0,100 mm</p> <p>0,82 mm ± 83 Ø</p> <p>217.021 55202010</p>  <p>→ 0,101 mm → 0,200 mm</p> <p>0,92 mm ± 83 Ø 1 ⊗</p> <p>217.031 55202011</p>  <p>→ 0,201 mm → 0,295 mm</p> <p>1,02 mm ± 83 Ø 2 ⊗</p>	<p>ZKS 152.440 7775920 (10x) M 12x1,25x218 →Mot. 5693775 (Stilo) →Mot. 5689744 (Bravo)</p>  <p>ZKS 687.330 55 214 216 (10x) M 12x1,25x219 Mot. 5689745 (Bravo)→ Mot. 5693776 (Stilo)→</p>  <p>ZKS 642.100 M 12x1,25x224,5 Mot. 5693776 (Stilo)→ Mot. 5689745 (Bravo)→</p> 	<p>430.400 55197598</p> 











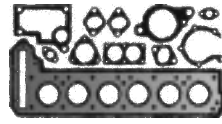
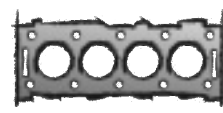

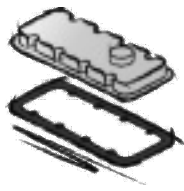





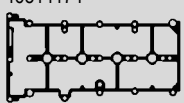

			<p>a) </p> <p>b) </p>	<p>K: </p> <p>N: </p>	
<p>VAS 294.250 FPM 294.110 7553637 FPM 8x</p>	<p>458.360 46467747 </p>	<p>879.280 71738458 </p>	<p>a) 030.793 Dirko HT</p> <p>b) 877.920 incl. 339.580 46476967 M 18x1,5x22</p> <p>b) 339.580 55196309 CU A 18x26x1,5</p>	<p>K:← 069.590 7628850 AW/BS RD FPM 31x41x7</p> <p>K:→ 199.191 71718365 SP LD FPM 93x12</p> <p>N:← 505.838 60809849 ASW RD FPM 30x42x7</p>	<p>TLS 434.310 </p>
<p>VAS 332.470 46743167 FPM 332.330 46743167 FPM 16x</p>	<p>448.510 73502761 </p>	<p>439.000 46816020 </p>	<p>a) 036.164 Dirko HT / EU</p> <p>a) 510.031 Dirko HT / USA/CDN/MEX</p> <p>a) 527.291 Dirko HT / RU</p> <p>a) 648.661 Dirko HT / BR</p> <p>b) 877.920 incl. 339.580 46476967 M 18x1,5x22</p> <p>b) 339.580 55196309 CU A 18x26x1,5</p>	<p>K:← 069.590 7628850 AW/BS RD FPM 31x41x7</p> <p>K:→ 199.191 71718365 SP LD FPM 93x12</p> <p>N:← 434.500 46802577 A/BS RD FPM 30x45x7</p>	<p>TLS 434.420 </p>
<p>VAS 294.250 FPM 294.110 7553637 FPM 8x</p>	<p>458.360 46467747 </p>	<p>879.280 71738458 </p>	<p>a) 030.793 Dirko HT</p> <p>b) 877.920 incl. 339.580 46476967 M 18x1,5x22</p> <p>b) 339.580 55196309 CU A 18x26x1,5</p>	<p>K:← 069.590 7628850 AW/BS RD FPM 31x41x7</p> <p>K:→ 199.191 71718365 SP LD FPM 93x12</p> <p>N:← 505.838 60809849 ASW RD FPM 30x42x7</p>	



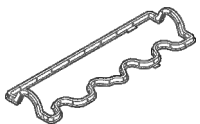





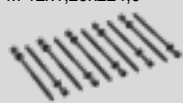
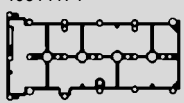







<p>FIAT</p> 				
<p>192 B1.000</p> <p>4 Cyl. 1910 ccm Cyl. 82,0 Ø</p> <p>Stilo JTD 02/2004 → 08/2008</p>	<p>ES⊕ 491.980 71730214</p>  <p>CS 387.580 71730404</p>	<p>217.052 55200890</p>  <p>→ 0,100 mm</p> <p>0,82 mm $\frac{1}{2}$ 83 Ø</p> <p>008.822 55201694</p>  <p>→ 0,101 mm</p> <p>→ 0,200 mm</p> <p>0,92 mm $\frac{1}{2}$ 83 Ø</p> <p>1 ⊗</p> <p>008.832 55201695</p>  <p>→ 0,201 mm</p> <p>→ 0,295 mm</p> <p>1,02 mm $\frac{1}{2}$ 83 Ø</p> <p>2 ⊗</p>	<p>ZKS 642.100 M 12x1,25x224,5</p>  <p>ZKS 687.330 55 214 216 (10x) M 12x1,25x219</p>	<p>875.350 46814174</p> 
<p>192 B4.000</p> <p>4 Cyl. 1910 ccm Cyl. 82,0 Ø</p> <p>Bravo Multijet 11/2006 → 12/2009</p> <p>Stilo JTD 10/2001 → 11/2006</p>	<p>ES⊕ 498.980 71739971</p>  <p>CS 387.580 71730404</p>	<p>217.001 55200891</p>  <p>→ 0,020 mm</p> <p>→ 0,100 mm</p> <p>0,82 mm $\frac{1}{2}$ 83 Ø</p> <p>217.021 55202010</p>  <p>→ 0,101 mm</p> <p>→ 0,200 mm</p> <p>0,92 mm $\frac{1}{2}$ 83 Ø</p> <p>1 ⊗</p> <p>217.031 55202011</p>  <p>→ 0,201 mm</p> <p>→ 0,295 mm</p> <p>1,02 mm $\frac{1}{2}$ 83 Ø</p> <p>2 ⊗</p>	<p>ZKS 152.440 7775920 (10x) M 12x1,25x218 →Mot. 5689744 (Bravo)</p>  <p>ZKS 642.100 M 12x1,25x224,5 Mot. 5689745 (Bravo)→</p>  <p>ZKS 687.330 55 214 216 (10x) M 12x1,25x219 Mot. 5689745 (Bravo)→</p>	<p>430.400 55197598</p> 
<p>199 A5.000</p> <p>4 Cyl. 1910 ccm Cyl. 82,0 Ø</p> <p>Grande Punto Multijet 10/2005 →</p>	<p>ES⊕ 498.980 71739971</p>  <p>OKS 724.580 71737925</p>  <p>OKS 926.020 71749333</p>	<p>217.001 55200891</p>  <p>→ 0,020 mm</p> <p>→ 0,100 mm</p> <p>0,82 mm $\frac{1}{2}$ 83 Ø</p> <p>217.021 55202010</p>  <p>→ 0,101 mm</p> <p>→ 0,200 mm</p> <p>0,92 mm $\frac{1}{2}$ 83 Ø</p> <p>1 ⊗</p> <p>217.031 55202011</p>  <p>→ 0,201 mm</p> <p>→ 0,295 mm</p> <p>1,02 mm $\frac{1}{2}$ 83 Ø</p> <p>2 ⊗</p>	<p>ZKS 152.440 7775920 (10x) M 12x1,25x218 →Mot. 5714215 (G. Punto)</p>  <p>ZKS 642.100 M 12x1,25x224,5 Mot. 5714216 (G. Punto)→</p>  <p>ZKS 687.330 55 214 216 (10x) M 12x1,25x219 Mot. 5714216 (G. Punto)→</p>	<p>430.400 55197598</p> 

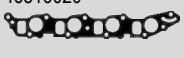





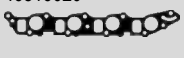



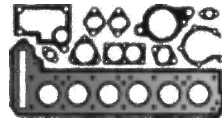
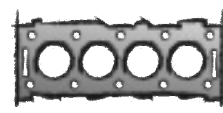

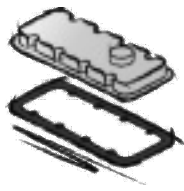





			<p>a) </p> <p>b) </p>	<p>K: </p> <p>N: </p>	
<p>VAS 332.470 46743167 FPM</p> <p>332.330 46743167 FPM 16x</p>	<p>448.510 73502761</p> 	<p>439.000 46816020</p> 	<p>a) 030.793 Dirko HT</p> <p>b) 877.920 incl. 339.580 46476967 M 18x1,5x22</p> <p>b) 339.580 55196309 CU A 18x26x1,5</p>	<p>K:← 069.590 7628850 AW/BS RD FPM 31x41x7</p> <p>K:→ 199.191 71718365 SP LD FPM 93x12</p> <p>N:← 434.500 46802577 A/BS RD FPM 30x45x7</p>	
<p>VAS 294.250 FPM</p> <p>294.110 7553637 FPM 8x</p>	<p>458.360 46467747</p> 	<p>879.280 71738458</p> 	<p>a) 030.793 Dirko HT</p> <p>b) 877.920 incl. 339.580 46476967 M 18x1,5x22</p> <p>b) 339.580 55196309 CU A 18x26x1,5</p>	<p>K:← 069.590 7628850 AW/BS RD FPM 31x41x7</p> <p>K:→ 199.191 71718365 SP LD FPM 93x12</p> <p>N:← 505.838 60809849 ASW RD FPM 30x42x7</p>	<p>TLS 434.420</p> 
<p>VAS 294.250 FPM</p> <p>294.110 7553637 FPM 8x</p>	<p>458.360 46467747</p> 	<p>879.280 71738458</p> 	<p>a) 030.793 Dirko HT</p> <p>b) 877.920 incl. 339.580 46476967 M 18x1,5x22</p> <p>b) 339.580 55196309 CU A 18x26x1,5</p>	<p>K:← 069.590 7628850 AW/BS RD FPM 31x41x7</p> <p>K:→ 199.191 71718365 SP LD FPM 93x12</p> <p>N:← 505.838 60809849 ASW RD FPM 30x42x7</p>	

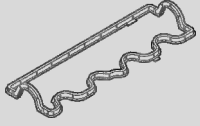





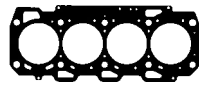

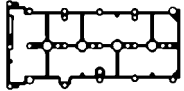



<p>FIAT</p> 				
<p>188 A3.000 223 A6.000</p> <p>4 Cyl. 1910 ccm Cyl. 82,0 Ø</p> <p>Doblo 03/2001 →</p> <p>Palio 03/2001 →</p> <p>Punto 09/1999 → 03/2012</p> <p>Siena 01/2004 → 12/2008</p> <p>Strada 12/2000 →</p>	<p>S⊕* 028.000 71715698 +7628850 +71718365 +40004400</p>  <p>ES⊕ 027.990 71715699</p> 	<p>028.020 46529117 0,80 mm $\frac{\pm}{\pm}$ 83 Ø </p> <p>028.030 46529118 0,90 mm $\frac{\pm}{\pm}$ 83 Ø </p> <p>028.040 46529119 1,00 mm $\frac{\pm}{\pm}$ 83 Ø </p>	<p>ZKS 152.440 7775920 (10x) M 12x1,25x218</p> 	<p>375.310 46548441</p> 
<p>223 A7.000 223 B1.000 223 B2.000</p> <p>4 Cyl. 1910 ccm Cyl. 82,0 Ø</p> <p>Doblo JTD 10/2001 →</p>	<p>ES⊕ 498.980 71739971</p>  <p>CS 387.580 71730404</p>	<p>217.001 55200891  0,020 mm → 0,100 mm 0,82 mm $\frac{\pm}{\pm}$ 83 Ø </p> <p>217.021 55202010  0,101 mm → 0,200 mm 0,92 mm $\frac{\pm}{\pm}$ 83 Ø </p> <p>217.031 55202011  0,201 mm → 0,295 mm 1,02 mm $\frac{\pm}{\pm}$ 83 Ø </p>	<p>ZKS 152.440 7775920 (10x) M 12x1,25x218 →Mot. 5689123 (Doblo)</p>  <p>ZKS 642.100 M 12x1,25x224,5 Mot. 5689124 (Doblo)→</p>  <p>ZKS 687.330 55 214 216 (10x) M 12x1,25x219 Mot. 5689124 (Doblo)→</p>	<p>430.400 55197598</p> 
<p>937 A4.000</p> <p>4 Cyl. 1910 ccm Cyl. 82,0 Ø</p> <p>Stilo JTD 09/2003 → 08/2008</p>	<p>ES⊕ 491.980 71730214</p>  <p>CS 387.580 71730404</p>	<p>843.833 ● 55195892  0,100 mm 0,82 mm $\frac{\pm}{\pm}$ 83 Ø </p> <p>217.052 55200890  0,100 mm 0,82 mm $\frac{\pm}{\pm}$ 83 Ø </p> <p>008.822 55201694  0,101 mm → 0,200 mm 0,92 mm $\frac{\pm}{\pm}$ 83 Ø </p> <p>008.832 55201695  0,201 mm → 0,295 mm 1,02 mm $\frac{\pm}{\pm}$ 83 Ø </p>	<p>ZKS 642.100 M 12x1,25x224,5</p>  <p>ZKS 687.330 55 214 216 (10x) M 12x1,25x219</p>	<p>875.350 46814174</p> 











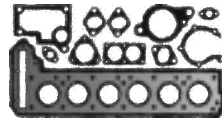
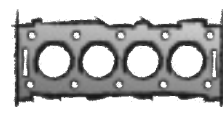

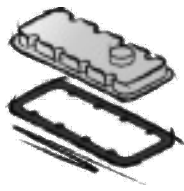







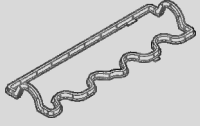

			<p>a) </p> <p>b) </p>	<p>K: </p> <p>N: </p>	
<p>VAS 294.250 FPM 294.110 7553637 FPM 8x</p>	<p>458.360 46467747 </p>	<p>375.230 46548450 4x </p>	<p>a) 030.793 Dirko HT</p> <p>b) 877.920 incl. 339.580 46476967 M 18x1,5x22</p> <p>b) 339.580 55196309 CU A 18x26x1,5</p>	<p>K:← 069.590 7628850 AW/BS RD FPM 31x41x7</p> <p>K:→ 199.191 71718365 SP LD FPM 93x12</p> <p>N:← 505.838 60809849 ASW RD FPM 30x42x7</p>	
<p>VAS 294.250 FPM 294.110 7553637 FPM 8x</p>	<p>458.360 46467747 </p>	<p>879.280 71738458 </p>	<p>a) 030.793 Dirko HT</p> <p>b) 877.920 incl. 339.580 46476967 M 18x1,5x22</p> <p>b) 339.580 55196309 CU A 18x26x1,5</p>	<p>K:← 069.590 7628850 AW/BS RD FPM 31x41x7</p> <p>K:→ 199.191 71718365 SP LD FPM 93x12</p> <p>N:← 505.838 60809849 ASW RD FPM 30x42x7</p>	<p>TLS 434.310 </p>
<p>VAS 332.470 46743167 FPM 332.330 46743167 FPM 16x</p>	<p>448.510 73502761 </p>	<p>439.000 46816020 </p>	<p>a) 030.793 Dirko HT</p> <p>b) 877.920 incl. 339.580 46476967 M 18x1,5x22</p> <p>b) 339.580 55196309 CU A 18x26x1,5</p>	<p>K:← 069.590 7628850 AW/BS RD FPM 31x41x7</p> <p>K:→ 199.191 71718365 SP LD FPM 93x12</p> <p>N:← 434.500 46802577 AVBS RD FPM 30x45x7</p>	













<p>FIAT</p> 				
<p>937 A5.000</p> <p>4 Cyl. 1910 ccm Cyl. 82,0 Ø</p> <p>Bravo Multijet 04/2007 → 12/2014</p> <p>Stilo JTD 09/2005 → 08/2008</p> <p>Stilo Multijet 09/2005 → 08/2008</p>	<p>ES⊕ 491.980 71730214 →Mot. 5192515</p>  <p>ES⊕ 585.020 Mot. 5192516→</p>  <p>CS 387.580 71730404</p>	<p>217.052 55200890</p>  <p>→ 0,100 mm</p> <p>0,82 mm ± 83 Ø</p> <p>008.822 55201694</p>  <p>→ 0,101 mm</p> <p>→ 0,200 mm</p> <p>0,92 mm ± 83 Ø</p> <p>1 ⊗</p> <p>008.832 55201695</p>  <p>→ 0,201 mm</p> <p>→ 0,295 mm</p> <p>1,02 mm ± 83 Ø</p> <p>2 ⊗</p>	<p>ZKS 642.100 M 12x1,25x224,5</p>  <p>ZKS 687.330 55 214 216 (10x) M 12x1,25x219</p>	<p>875.350 46814174</p> 
<p>937 A7.000</p> <p>4 Cyl. 1910 ccm Cyl. 82,0 Ø</p> <p>Stilo JTD 10/2001 → 08/2008</p>	<p>ES⊕ 498.980 71739971</p>  <p>CS 387.580 71730404</p>	<p>217.001 55200891</p>  <p>→ 0,020 mm</p> <p>→ 0,100 mm</p> <p>0,82 mm ± 83 Ø</p> <p>217.021 55202010</p>  <p>→ 0,101 mm</p> <p>→ 0,200 mm</p> <p>0,92 mm ± 83 Ø</p> <p>1 ⊗</p> <p>217.031 55202011</p>  <p>→ 0,201 mm</p> <p>→ 0,295 mm</p> <p>1,02 mm ± 83 Ø</p> <p>2 ⊗</p>	<p>ZKS 152.440 7775920 (10x) M 12x1,25x218 →Mot. 5693775 (Stilo)</p>  <p>ZKS 642.100 M 12x1,25x224,5 Mot. 5693776 (Stilo)→</p>  <p>ZKS 687.330 55 214 216 (10x) M 12x1,25x219 Mot. 5693776 (Stilo)→</p>	<p>430.400 55197598</p> 
<p>939 A2.000</p> <p>4 Cyl. 1910 ccm Cyl. 82,0 Ø</p> <p>Croma Multijet 06/2005 → 12/2011</p>	<p>ES⊕ 491.980 71730214 →Mot. 5192515</p>  <p>ES⊕ 585.020 Mot. 5192516→</p>  <p>OKS 724.580 71737925</p>  <p>OKS 926.020 71749333</p>	<p>217.052 55200890</p>  <p>→ 0,100 mm</p> <p>0,82 mm ± 83 Ø</p> <p>008.822 55201694</p>  <p>→ 0,101 mm</p> <p>→ 0,200 mm</p> <p>0,92 mm ± 83 Ø</p> <p>1 ⊗</p> <p>008.832 55201695</p>  <p>→ 0,201 mm</p> <p>→ 0,295 mm</p> <p>1,02 mm ± 83 Ø</p> <p>2 ⊗</p>	<p>ZKS 642.100 M 12x1,25x224,5</p>  <p>ZKS 687.330 55 214 216 (10x) M 12x1,25x219</p>	<p>875.350 46814174</p> 





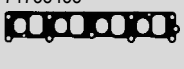

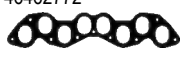



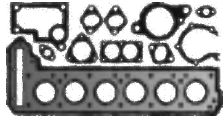
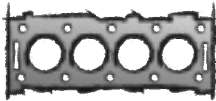

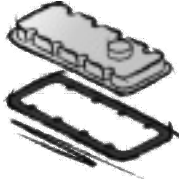











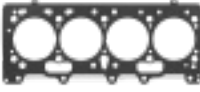

			<p>a) </p> <p>b) </p>	<p>K: </p> <p>N: </p>	
<p>VAS 332.470 46743167 FPM →Mot. 5192515</p> <p>332.330 46743167 FPM →Mot. 5192515 16x</p> <p>506.550 55183812 FPM Mot. 5192516→ 16x</p>	<p>448.510 73502761</p> 	<p>439.000 46816020</p> 	<p>a) 030.793 Dirko HT</p> <p>b) 877.920 incl. 339.580 46476967 M 18x1,5x22</p> <p>b) 339.580 55196309 CU A 18x26x1,5</p>	<p>K:← 069.590 7628850 AW/BS RD FPM 31x41x7</p> <p>K:→ 199.191 71718365 SP LD FPM 93x12</p> <p>N:← 434.500 46802577 A/BS RD FPM 30x45x7</p>	<p>TLS 434.420</p> 
<p>VAS 294.250 FPM</p> <p>294.110 7553637 FPM 8x</p>	<p>458.360 46467747</p> 	<p>879.280 71738458</p> 	<p>a) 030.793 Dirko HT</p> <p>b) 877.920 incl. 339.580 46476967 M 18x1,5x22</p> <p>b) 878.030 incl. 359.300 M 18x1,5x20</p> <p>b) 339.580 55196309 CU A 18x26x1,5</p> <p>b) 359.300 FPM A 18x26x1,5 FE/FPM</p>	<p>K:← 069.590 7628850 AW/BS RD FPM 31x41x7</p> <p>K:→ 199.191 71718365 SP LD FPM 93x12</p> <p>N:← 505.838 60809849 ASW RD FPM 30x42x7</p>	<p>TLS 434.420</p> 
<p>VAS 332.470 46743167 FPM →Mot. 5192515</p> <p>332.330 46743167 FPM →Mot. 5192515 16x</p> <p>506.550 55183812 FPM Mot. 5192516→ 16x</p>	<p>448.510 73502761</p> 	<p>439.000 46816020</p> 	<p>a) 030.793 Dirko HT</p> <p>b) 877.920 incl. 339.580 46476967 M 18x1,5x22</p> <p>b) 878.030 incl. 359.300 M 18x1,5x20</p> <p>b) 339.580 55196309 CU A 18x26x1,5</p> <p>b) 359.300 FPM A 18x26x1,5 FE/FPM</p>	<p>K:← 069.590 7628850 AW/BS RD FPM 31x41x7</p> <p>K:→ 199.191 71718365 SP LD FPM 93x12</p> <p>N:← 434.500 46802577 A/BS RD FPM 30x45x7</p>	<p>TLS 703.940</p> 













<p>FIAT</p> 				
<p>939 A1.000 939 A7.000</p> <p>4 Cyl. 1910 ccm Cyl. 82,0 Ø</p> <p>Croma Multijet 06/2005 →</p> <p>Grande Punto Multijet 10/2005 →</p>	<p>ES⊕ 498.980 71739971</p>  <p>OXS 724.580 71737925</p>  <p>OXS 926.020 71749333</p>	<p>217.001 55200891</p>  <p>0,020 mm →</p> <p>0,100 mm</p> <p>0,82 mm $\frac{1}{2}$ 83 Ø</p> <p>217.021 55202010</p>  <p>0,101 mm →</p> <p>0,200 mm</p> <p>0,92 mm $\frac{1}{2}$ 83 Ø</p> <p>1 ⊗</p> <p>217.031 55202011</p>  <p>0,201 mm →</p> <p>0,295 mm</p> <p>1,02 mm $\frac{1}{2}$ 83 Ø</p> <p>2 ⊗</p>	<p>ZKS 152.440 7775920 (10x) M 12x1,25x218 →Mot. 5714215 (G. Punto) →Mot. 5689696 (Croma)</p>  <p>ZKS 687.330 55 214 216 (10x) M 12x1,25x219 Mot. 5689697 (Croma)→ Mot. 5714216 (G. Punto)→</p> <p>ZKS 642.100 M 12x1,25x224,5 Mot. 5714216 (G. Punto)→ Mot. 5689697 (Croma)→</p> 	<p>430.400 55197598</p> 
<p>939 A8.000</p> <p>4 Cyl. 1910 ccm Cyl. 82,0 Ø</p> <p>Croma Multijet 12/2005 →</p>	<p>ES⊕ 491.980 71730214 →Mot. 5192515</p>  <p>ES⊕ 585.020 Mot. 5192516→</p>  <p>OXS 724.580 71737925</p>  <p>OXS 926.020 71749333</p>	<p>217.052 55200890</p>  <p>0,100 mm</p> <p>0,82 mm $\frac{1}{2}$ 83 Ø</p> <p>008.822 55201694</p>  <p>0,101 mm →</p> <p>0,200 mm</p> <p>0,92 mm $\frac{1}{2}$ 83 Ø</p> <p>1 ⊗</p> <p>008.832 55201695</p>  <p>0,201 mm →</p> <p>0,295 mm</p> <p>1,02 mm $\frac{1}{2}$ 83 Ø</p> <p>2 ⊗</p>	<p>ZKS 642.100 M 12x1,25x224,5</p>  <p>ZKS 687.330 55 214 216 (10x) M 12x1,25x219</p>	<p>875.350 46814174</p> 











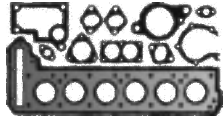
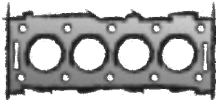

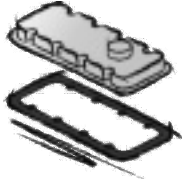

			<p>a) </p> <p>b) </p>	<p>K: </p> <p>N: </p>	
<p>VAS 294.250 FPM 294.110 7553637 FPM 8x</p>	<p>458.360 46467747 </p>	<p>879.280 71738458 </p>	<p>a) 030.793 Dirko HT b) 877.920 incl. 339.580 46476967 M 18x1,5x22 b) 878.030 incl. 359.300 M 18x1,5x20 b) 339.580 55196309 CU A 18x26x1,5 b) 359.300 FPM A 18x26x1,5 FE/FPM</p>	<p>K:← 069.590 7628850 AW/BS RD FPM 31x41x7 K:→ 199.191 71718365 SP LD FPM 93x12 N:← 505.838 60809849 ASW RD FPM 30x42x7</p>	<p>TLS 703.930 </p>
<p>VAS 332.470 46743167 FPM →Mot. 5192515 332.330 46743167 FPM →Mot. 5192515 16x 506.550 55183812 FPM Mot. 5192516→ 16x</p>	<p>448.510 73502761 </p>	<p>439.000 46816020 </p>	<p>a) 030.793 Dirko HT b) 877.920 incl. 339.580 46476967 M 18x1,5x22 b) 878.030 incl. 359.300 M 18x1,5x20 b) 339.580 55196309 CU A 18x26x1,5 b) 359.300 FPM A 18x26x1,5 FE/FPM</p>	<p>K:← 069.590 7628850 AW/BS RD FPM 31x41x7 K:→ 199.191 71718365 SP LD FPM 93x12 N:← 434.500 46802577 A/BS RD FPM 30x45x7</p>	

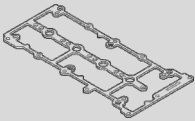

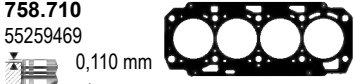

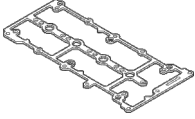



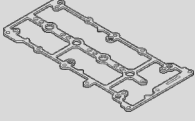





<p>FIAT</p> 				
<p>D19AA</p> <p>4 Cyl. 1910 ccm Cyl. 82,0 Ø</p> <p>Sedici Multijet 06/2006 → 10/2011</p>	<p>ES⊕ 498.980 71739971</p>  <p>OKS 724.580 71737925</p>  <p>OKS 926.020 71749333</p>	<p>217.001 55200891</p>  <p>0,020 mm → 0,100 mm</p> <p>0,82 mm $\frac{\pm}{\text{mm}}$ 83 Ø</p> <p>217.021 55202010</p>  <p>0,101 mm → 0,200 mm</p> <p>0,92 mm $\frac{\pm}{\text{mm}}$ 83 Ø 1 ⊗</p> <p>217.031 55202011</p>  <p>0,201 mm → 0,295 mm</p> <p>1,02 mm $\frac{\pm}{\text{mm}}$ 83 Ø 2 ⊗</p>	<p>ZKS 152.440 7775920 (10x) M 12x1,25x218 →Mot. 5687297 (Sedici)</p>  <p>ZKS 642.100 M 12x1,25x224,5 Mot. 5687298 (Sedici)→</p>  <p>ZKS 687.330 55 214 216 (10x) M 12x1,25x219 Mot. 5687298 (Sedici)→</p>	<p>430.400 55197598</p> 
<p>149 B5.046 160 A6.000/046 160 B6.046 160 D1.000 160B6000</p> <p>4 Cyl. 1929 ccm Cyl. 82,6 Ø</p> <p>Tempra 04/1990 → 07/1996</p> <p>Tempra TD 05/1990 → 08/1996</p> <p>Tipo TD 04/1990 → 04/1995</p> <p>Uno 01/1989 → 03/1994</p>	<p>ES⊕ 143.071 ● 5892429 +40004940</p> 	<p>724.760 46431639 1,65 mm $\frac{\pm}{\text{mm}}$ 83,5 Ø</p>  <p>724.770 46431640 1,75 mm $\frac{\pm}{\text{mm}}$ 83,5 Ø</p>  <p>724.780 46431641 1,85 mm $\frac{\pm}{\text{mm}}$ 83,5 Ø</p>  <p>724.790 46431642 1,95 mm $\frac{\pm}{\text{mm}}$ 83,5 Ø</p>  <p>986.373 46451593 1,65 mm $\frac{\pm}{\text{mm}}$ 83 Ø</p>  <p>986.381 46451594 1,75 mm $\frac{\pm}{\text{mm}}$ 83 Ø 1 ▽</p>  <p>773.990 46451595 1,85 mm $\frac{\pm}{\text{mm}}$ 83 Ø 2 ▽</p>  <p>986.390 46451596 1,95 mm $\frac{\pm}{\text{mm}}$ 83 Ø 3 ▽</p> 	<p>ZKS 760.510 7653650 (10x) M 12x1,25x134</p> 	<p>480.980 7702774</p> 



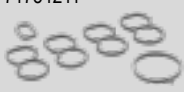







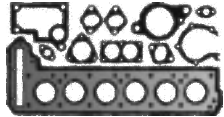
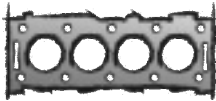

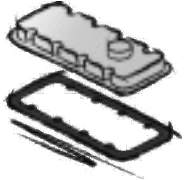
			<p>a) </p> <p>b) </p>	<p>K: </p> <p>N: </p>	
<p>VAS 294.250 FPM</p>	<p>458.360 46467747</p> 	<p>879.280 71738458</p> 	<p>a) 030.793 Dirko HT</p> <p>b) 877.920 incl. 339.580 46476967 M 18x1,5x22</p> <p>b) 339.580 55196309 CU A 18x26x1,5</p>	<p>K:← 069.590 7628850 AW/BS RD FPM 31x41x7</p> <p>K:→ 199.191 71718365 SP LD FPM 93x12</p> <p>N:← 505.838 60809849 ASW RD FPM 30x42x7</p>	<p>TLS 703.930</p> 
<p>VAS 294.250 FPM</p> <p>294.110 7553637 FPM 8x</p>	<p>⇒</p>	<p>480.990 46462772</p> 	<p>a) 480.960 7647596</p>  <p>b) 587.100 7734022 M 22x1,5x13</p>	<p>K:← 440.730 40004260 AW/BS RD ACM 30x43x8</p> <p>K:→ 440.830 40004300 AW/BS LD FPM 74x90x10</p> <p>N:← 440.750 40004940 AW/BS RD FPM 30x52x7</p>	



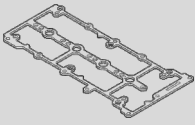



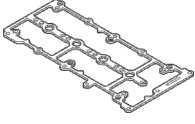

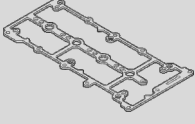





<p>FIAT</p> 				
<p>160 A7.000 230 A2.000 230 A3.000 230 A4.000</p> <p>4 Cyl. 1929 ccm Cyl. 82,6 Ø</p> <p>Brava 10/1995 → 10/2001</p> <p>Bravo 10/1995 → 10/2001</p> <p>Ducato 03/1994 → 04/2002</p> <p>Ducato TD 03/1994 → 04/2002</p> <p>Tempra 07/1991 → 08/1996</p> <p>Tipo 07/1991 → 08/1995</p>	<p>S⊕* 143.041 5890694 +40004940 +40004300 +40004260</p>  <p>ES⊕ 143.031 5890695 +40004940</p> 	<p>724.760 46431639 1,65 mm $\frac{+}{-}$ 83,5 Ø </p> <p>724.770 46431640 1,75 mm $\frac{+}{-}$ 83,5 Ø </p> <p>724.780 46431641 1,85 mm $\frac{+}{-}$ 83,5 Ø </p> <p>724.790 46431642 1,95 mm $\frac{+}{-}$ 83,5 Ø </p> <p>986.373 46451593 1,65 mm $\frac{+}{-}$ 83 Ø </p> <p>986.381 46451594 1,75 mm $\frac{+}{-}$ 83 Ø </p> <p>773.990 46451595 1,85 mm $\frac{+}{-}$ 83 Ø </p> <p>986.390 46451596 1,95 mm $\frac{+}{-}$ 83 Ø </p>	<p>ZKS 760.510 7653650 (10x) M 12x1,25x134</p> 	<p>480.980 7702774</p> 
<p>149 A1.000 149 B1.000 280 A1.000</p> <p>4 Cyl. 1929 ccm Cyl. 82,6 Ø</p> <p>Ducato 02/1987 → 05/1994</p> <p>Ducato TD 03/1989 → 03/1994</p> <p>Regata 04/1984 → 07/1989</p> <p>Talento 03/1989 → 03/1994</p> <p>Tempra 07/1991 → 08/1996</p> <p>Tipo 07/1991 → 08/1995</p>	<p>S⊕* 143.041 5890694 +40004940 +40004300 +40004260</p>  <p>ES⊕ 143.031 5890695 +40004940</p> 	<p>724.760 46431639 1,65 mm $\frac{+}{-}$ 83,5 Ø </p> <p>724.770 46431640 1,75 mm $\frac{+}{-}$ 83,5 Ø </p> <p>724.780 46431641 1,85 mm $\frac{+}{-}$ 83,5 Ø </p> <p>724.790 46431642 1,95 mm $\frac{+}{-}$ 83,5 Ø </p> <p>986.373 46451593 1,65 mm $\frac{+}{-}$ 83 Ø </p> <p>986.381 46451594 1,75 mm $\frac{+}{-}$ 83 Ø </p> <p>773.990 46451595 1,85 mm $\frac{+}{-}$ 83 Ø </p> <p>986.390 46451596 1,95 mm $\frac{+}{-}$ 83 Ø </p>	<p>ZKS 760.510 7653650 (10x) M 12x1,25x134</p> 	<p>480.980 7702774</p> 











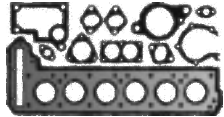
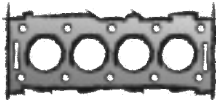

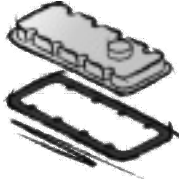



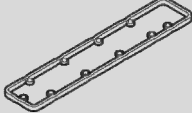
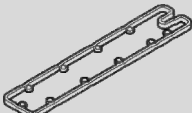



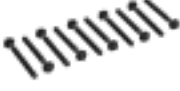
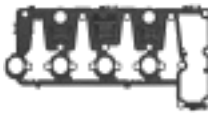

			<p>a) </p> <p>b) </p>	<p>K: </p> <p>N: </p>	
<p>VAS 294.250 FPM</p> <p>294.110 7553637 FPM 8x</p>	<p>⇒</p>	<p>480.990 46462772</p> 	<p>a) 480.960 7647596</p>  <p>b) 587.100 7734022 M 22x1,5x13</p>	<p>K:← 440.730 40004260 AW/BS RD ACM 30x43x8</p> <p>K:→ 440.830 40004300 AW/BS LD FPM 74x90x10</p> <p>N:← 440.750 40004940 AW/BS RD FPM 30x52x7</p>	
<p>VAS 294.250 FPM</p> <p>294.110 7553637 FPM 8x</p>	<p>⇒</p>	<p>480.990 46462772</p> 	<p>a) 671.100 5959226 →12/1989</p>  <p>a) 480.960 7647596 01/1990→</p>  <p>b) 587.100 7734022 M 22x1,5x13</p>	<p>K:← 440.730 40004260 AW/BS RD ACM 30x43x8</p> <p>K:→ 440.830 40004300 AW/BS LD FPM 74x90x10</p> <p>N:← 440.750 40004940 AW/BS RD FPM 30x52x7</p>	















<p>FIAT</p> 				
<p>198 A5.000 198 A8.000 250 A1.000 250 A2.000 263 A1.000 844 A2.000</p> <p>4 Cyl. 1956 ccm Cyl. 83,0 Ø</p> <p>Bravo Multijet 09/2008 → 12/2014</p> <p>Doblo Multijet 01/2010 →</p> <p>Ducato Multijet 06/2011 →</p>	<p>ES⊕ 693.880 71769839</p>  <p>CS* 592.910 71749743 +71718365</p> <p>CS 926.720</p>	<p>758.710 55259469</p>  <p>0,110 mm → 0,230 mm</p> <p>0,95 mm $\frac{1}{2}$ 84 Ø</p> <p>758.680 55259470</p>  <p>0,231 mm → 0,330 mm</p> <p>1,05 mm $\frac{1}{2}$ 84 Ø 1 ⊗</p> <p>758.690 55259471</p>  <p>0,331 mm → 0,425 mm</p> <p>1,15 mm $\frac{1}{2}$ 84 Ø 2 ⊗</p>	<p>ZKS 687.330 55 214 216 (10x) M 12x1,25x219</p>	<p>748.591 55205111</p> 
<p>552 63 087</p> <p>4 Cyl. 1956 ccm Cyl. 83,0 Ø</p> <p>500X Multijet 09/2014 →</p>	<p>ES⊕ 687.350</p>  <p>CS 926.720</p>	<p>758.710 55259469</p>  <p>0,110 mm → 0,230 mm</p> <p>0,95 mm $\frac{1}{2}$ 84 Ø</p> <p>758.680 55259470</p>  <p>0,231 mm → 0,330 mm</p> <p>1,05 mm $\frac{1}{2}$ 84 Ø 1 ⊗</p> <p>758.690 55259471</p>  <p>0,331 mm → 0,425 mm</p> <p>1,15 mm $\frac{1}{2}$ 84 Ø 2 ⊗</p>	<p>ZKS 687.330 55 214 216 (10x) M 12x1,25x219</p>	<p>748.591 55205111</p> 
<p>552 63 088</p> <p>4 Cyl. 1956 ccm Cyl. 83,0 Ø</p> <p>500X Multijet 09/2014 →</p> <p>Toro 01/2016 →</p>	<p>ES⊕ 687.350</p>  <p>CS 926.720</p>	<p>758.710 55259469</p>  <p>0,110 mm → 0,230 mm</p> <p>0,95 mm $\frac{1}{2}$ 84 Ø</p> <p>758.680 55259470</p>  <p>0,231 mm → 0,330 mm</p> <p>1,05 mm $\frac{1}{2}$ 84 Ø 1 ⊗</p> <p>758.690 55259471</p>  <p>0,331 mm → 0,425 mm</p> <p>1,15 mm $\frac{1}{2}$ 84 Ø 2 ⊗</p>	<p>ZKS 687.330 55 214 216 (10x) M 12x1,25x219</p>	<p>748.591 55205111</p> 











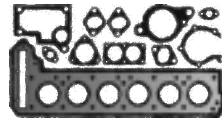
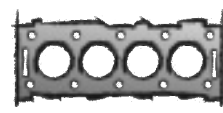

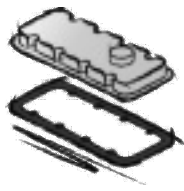



			<p>a) </p> <p>b) </p>	<p>K: </p> <p>N: </p>	
<p>506.550 55183812 FPM 16x</p>	<p>748.510 55210879</p> 	<p>AAS 340.470 71754211</p> 	<p>a) 030.793 Dirko HT</p> <p>b) 877.920 incl. 339.580 46476967 M 18x1,5x22</p> <p>b) 878.030 incl. 359.300 M 18x1,5x20</p> <p>b) 339.580 55196309 CU A 18x26x1,5</p> <p>b) 359.300 FPM A 18x26x1,5 FE/FPM</p>	<p>K:← 069.590 7628850 AW/BS RD FPM 31x41x7</p> <p>K:→ 199.191 71718365 SP LD FPM 93x12</p> <p>N:← 434.500 46802577 A/BS RD FPM 30x45x7</p>	
<p>506.550 55183812 FPM 16x</p>	<p>748.530 55222403 Euro 5</p>  <p>907.400 Euro 6</p> 	<p>AAS 340.470 71754211</p> 	<p>a) 030.793 Dirko HT</p> <p>b) 877.920 incl. 339.580 46476967 M 18x1,5x22</p> <p>b) 878.030 incl. 359.300 M 18x1,5x20</p> <p>b) 339.580 55196309 CU A 18x26x1,5</p> <p>b) 359.300 FPM A 18x26x1,5 FE/FPM</p>	<p>K:← 069.590 7628850 AW/BS RD FPM 31x41x7</p> <p>K:→ 199.191 71718365 SP LD FPM 93x12</p> <p>N:← 434.500 46802577 A/BS RD FPM 30x45x7</p>	<p>TLS 803.330</p>
<p>506.550 55183812 FPM 16x</p>	<p>748.530 55222403 Euro 5</p>  <p>907.400 Euro 6</p> 	<p>AAS 340.470 71754211</p> 	<p>a) 030.793 Dirko HT</p> <p>b) 877.920 incl. 339.580 46476967 M 18x1,5x22</p> <p>b) 878.030 incl. 359.300 M 18x1,5x20</p> <p>b) 339.580 55196309 CU A 18x26x1,5</p> <p>b) 359.300 FPM A 18x26x1,5 FE/FPM</p>	<p>K:← 069.590 7628850 AW/BS RD FPM 31x41x7</p> <p>K:→ 199.191 71718365 SP LD FPM 93x12</p> <p>N:← 434.500 46802577 A/BS RD FPM 30x45x7</p>	<p>TLS 803.330 500X (334)</p>



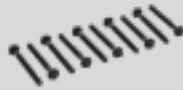





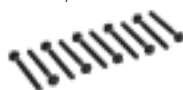
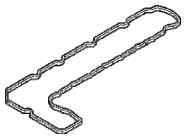



<p>FIAT</p> 				
<p>552 83 099</p> <p>4 Cyl. 1956 ccm Cyl. 83,0 Ø</p> <p>500X Multijet 09/2014 →</p>	<p>ES⊕ 687.350</p>  <p>CS 926.720</p>	<p>758.710 55259469</p>  <p>0,110 mm → 0,230 mm</p> <p>0,95 mm $\frac{+}{-}$ 84 Ø</p> <p>758.680 55259470</p>  <p>0,231 mm → 0,330 mm</p> <p>1,05 mm $\frac{+}{-}$ 84 Ø 1 ⊗</p> <p>758.690 55259471</p>  <p>0,331 mm → 0,425 mm</p> <p>1,15 mm $\frac{+}{-}$ 84 Ø 2 ⊗</p>	<p>ZKS 687.330 55 214 216 (10x) M 12x1,25x219</p>	<p>748.591 55205111</p> 
<p>939 B5.000 940 A5.000</p> <p>4 Cyl. 1956 ccm Cyl. 83,0 Ø</p> <p>Freemont JTD 08/2011 →</p>	<p>ES⊕ 940.460</p>  <p>CS 926.720</p>	<p>758.710 55259469</p>  <p>0,110 mm → 0,230 mm</p> <p>0,95 mm $\frac{+}{-}$ 84 Ø</p> <p>758.680 55259470</p>  <p>0,231 mm → 0,330 mm</p> <p>1,05 mm $\frac{+}{-}$ 84 Ø 1 ⊗</p> <p>758.690 55259471</p>  <p>0,331 mm → 0,425 mm</p> <p>1,15 mm $\frac{+}{-}$ 84 Ø 2 ⊗</p>		<p>748.591 55205111</p> 
<p>D20AA</p> <p>4 Cyl. 1956 ccm Cyl. 83,0 Ø</p> <p>Sedici Multijet 06/2006 → 10/2014</p>	<p>ES⊕ 693.880 71769839</p>  <p>CS* 592.910 71749743 +71718365</p> <p>CS 926.720</p>		<p>ZKS 687.330 55 214 216 (10x) M 12x1,25x219</p>	<p>748.591 55205111</p> 











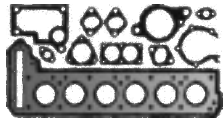
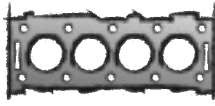

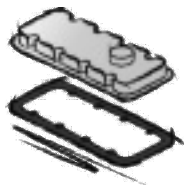
			<p>a) </p> <p>b) </p>	<p>K: </p> <p>N: </p>	
<p>506.550 55183812 FPM 16x</p>	<p>748.530 55222403 Euro 5  907.400 Euro 6 </p>	<p>AAS 340.470 71754211 </p>	<p>a) 030.793 Dirko HT</p> <p>b) 877.920 incl. 339.580 46476967 M 18x1,5x22</p> <p>b) 878.030 incl. 359.300 M 18x1,5x20</p> <p>b) 339.580 55196309 CU A 18x26x1,5</p> <p>b) 359.300 FPM A 18x26x1,5 FE/FPM</p>	<p>K:← 069.590 7628850 AW/BS RD FPM 31x41x7</p> <p>K:→ 199.191 71718365 SP LD FPM 93x12</p> <p>N:← 434.500 46802577 A/BS RD FPM 30x45x7</p>	
<p>506.550 55183812 FPM 16x</p>	<p>748.530 55222403 Euro 5 </p>	<p>AAS 340.470 71754211 </p>	<p>a) 030.793 Dirko HT</p> <p>b) 877.920 incl. 339.580 46476967 M 18x1,5x22</p> <p>b) 878.030 incl. 359.300 M 18x1,5x20</p> <p>b) 339.580 55196309 CU A 18x26x1,5</p> <p>b) 359.300 FPM A 18x26x1,5 FE/FPM</p>	<p>K:← 069.590 7628850 AW/BS RD FPM 31x41x7</p> <p>K:→ 199.191 71718365 SP LD FPM 93x12</p> <p>N:← 434.500 46802577 A/BS RD FPM 30x45x7</p>	<p>TLS 940.491</p>
<p>506.550 55183812 FPM 16x</p>	<p>748.510 55210879 </p>	<p>AAS 340.470 71754211 </p>	<p>a) 030.793 Dirko HT</p> <p>b) 877.920 incl. 339.580 46476967 M 18x1,5x22</p> <p>b) 878.030 incl. 359.300 M 18x1,5x20</p> <p>b) 339.580 55196309 CU A 18x26x1,5</p> <p>b) 359.300 FPM A 18x26x1,5 FE/FPM</p>	<p>K:← 069.590 7628850 AW/BS RD FPM 31x41x7</p> <p>K:→ 199.191 71718365 SP LD FPM 93x12</p> <p>N:← 434.500 46802577 A/BS RD FPM 30x45x7</p>	











<p>FIAT</p> 				
<p>RFN (EW10J4)</p> <p>4 Cyl. 1997 ccm Cyl. 85,0 Ø</p> <p>Scudo 05/2000 → 12/2006</p> <p>Ulysse 09/2000 → 06/2011</p>	<p>ES⊕ 331.600 CS* 458.810</p>	<p>125.911 9636017380 85,5 Ø</p>  <p>724.500 1,10 mm ± 85,5 Ø</p>  <p>724.510 1,40 mm ± 85,5 Ø</p> 	<p>ZKS 262.820 9647888280 (10x) M 11x1,5x141</p> 	<p>331.540 9463377480 E</p>  <p>331.550 9463377580 A</p> 
<p>RH02 RHH</p> <p>4 Cyl. 1997 ccm Cyl. 85,0 Ø</p> <p>Scudo Multijet 07/2010 →</p>	<p>S⊕* 587.250</p>  <p>ES⊕ 587.150</p>  <p>CS* 572.860</p>	<p>442.802 9682002980 1,25 mm ± 85,8 Ø 1 ⊗</p>  <p>442.812 9682013280 1,30 mm ± 85,8 Ø 2 ⊗</p>  <p>442.822 9682013380 1,35 mm ± 85,8 Ø 3 ⊗</p>  <p>442.832 9682013580 1,40 mm ± 85,8 Ø 2 ⊗</p> 	<p>ZKS 267.551 9646397880 (10x) M 12x1,5x121</p> 	<p>453.500 9671432980</p> 
<p>RHG</p> <p>4 Cyl. 1997 ccm Cyl. 85,0 Ø</p> <p>Scudo Multijet 01/2007 →</p>	<p>S⊕* 527.660</p>   <p>ES⊕ 527.550</p>  	<p>135.052 9644450580 0,550 mm → 0,600 mm 1,25 mm ± 86 Ø 1 ⊗</p>  <p>153.002 9644450680 0,610 mm → 0,650 mm 1,30 mm ± 86 Ø 2 ⊗</p>  <p>153.142 9644450780 0,660 mm → 0,710 mm 1,35 mm ± 86 Ø 3 ⊗</p>  <p>135.072 9644050880 0,710 mm → 0,750 mm 1,40 mm ± 86 Ø 4 ⊗</p> 	<p>ZKS 267.551 9646397880 (10x) M 12x1,5x121</p> 	<p>ZKHS 540.540</p> 











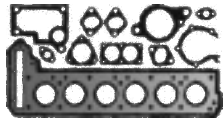
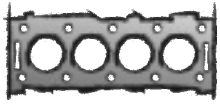

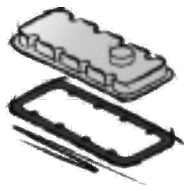
			<p>a) </p> <p>b) </p>	<p>K: </p> <p>N: </p>	
<p>VAS 155.750 FPM 149.360 9400956459 FPM 16x</p>	<p>136.690 9464038380 </p>	<p>216.500 9463260280 4x </p>	<p>a) 030.793 Dirko HT b) 813.036 9400313279 CU C 14x20x2</p>	<p>K:← 076.220 9456202980 AS RD FPM 40x55x6,5 K:→ 508.209 9614379380 ASW LD FPM/ACM 90x110x7 N:← 505.366 9653528780 9400236499 ASW RD FPM/ACM 36x50x7 2x</p>	
<p>VAS 453.750 FPM</p>	<p>521.960 9467613880 </p>		<p>a) 030.793 Dirko HT b) 877.930 incl. 108.502 M 10x1,25x13 b) 108.502 9400313409 CU A 10x21x2,1</p>	<p>K:← 393.990 9614194980 ASW RD PTFE/ACM 42x62x7 K:→ 394.012 ASW LD PTFE/ACM 90x110x8 N:← 153.740 9400807289 ASW RD FPM 27x47x7</p>	<p>TLS 587.210 </p>
<p>VAS 155.740 FPM 2x 136.940 9400956489 FPM 16x</p>	<p>156.770 9400349129 </p>	<p>AAS 540.540 </p>	<p>a) 036.164 Dirko HT / EU a) 510.031 Dirko HT / USA/CDN/MEX a) 527.291 Dirko HT / RU a) 648.661 Dirko HT / BR b) 877.950 incl. 813.036 M 14x1,25x13 b) 813.036 9400313279 CU C 14x20x2</p>	<p>K:← 393.990 9614194980 ASW RD PTFE/ACM 42x62x7 K:→ 394.012 ASW LD PTFE/ACM 90x110x8 N:← 153.740 9400807289 ASW RD FPM 27x47x7</p>	<p>TLS 714.640 </p>











<p>FIAT</p> 				
<p>RHK (DW10UTED4)</p> <p>4 Cyl. 1997 ccm Cyl. 85,0 Ø</p> <p>Scudo JTD 05/1999 → 12/2006</p>	<p>S⊕* 527.660</p>   <p>ES⊕ 527.550</p>  	<p>135.052 9644450580</p>  <p>0,550 mm → 0,600 mm</p> <p>1,25 mm $\frac{\pm}{\pm}$ 86 Ø 1 ⊗</p> <p>153.002 9644450680</p>  <p>0,610 mm → 0,650 mm</p> <p>1,30 mm $\frac{\pm}{\pm}$ 86 Ø 2 ⊗</p> <p>153.142 9644450780</p>  <p>0,660 mm → 0,710 mm</p> <p>1,35 mm $\frac{\pm}{\pm}$ 86 Ø 3 ⊗</p> <p>135.072 9644050880</p>  <p>0,710 mm → 0,750 mm</p> <p>1,40 mm $\frac{\pm}{\pm}$ 86 Ø 4 ⊗</p>	<p>ZKS 267.551 9646397880 (10x) M 12x1,5x121</p> 	<p>ZKHS 540.540</p> 
<p>RHM (DW10ATED4) RHW (DW10ATED4)</p> <p>4 Cyl. 1997 ccm Cyl. 85,0 Ø</p> <p>Scudo JTD 05/1999 → 12/2006</p> <p>Ulysse 05/1999 → 08/2002</p> <p>Ulysse JTD 08/2002 → 08/2006</p>	<p>ES⊕ 216.470 9463380080</p> 	<p>135.052 9644450580</p>  <p>0,550 mm → 0,600 mm</p> <p>1,25 mm $\frac{\pm}{\pm}$ 86 Ø 1 ⊗</p> <p>153.002 9644450680</p>  <p>0,610 mm → 0,650 mm</p> <p>1,30 mm $\frac{\pm}{\pm}$ 86 Ø 2 ⊗</p> <p>153.142 9644450780</p>  <p>0,660 mm → 0,710 mm</p> <p>1,35 mm $\frac{\pm}{\pm}$ 86 Ø 3 ⊗</p> <p>135.072 9644050880</p>  <p>0,710 mm → 0,750 mm</p> <p>1,40 mm $\frac{\pm}{\pm}$ 86 Ø 4 ⊗</p>	<p>ZKS 267.551 9646397880 (10x) M 12x1,5x121</p> 	<p>154.170 9463380380</p> 











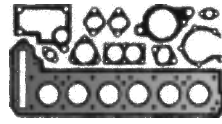
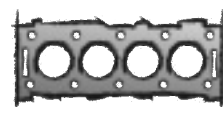

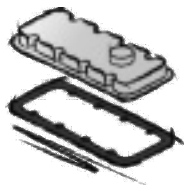

			<p>a) </p> <p>b) </p>	<p>K: </p> <p>N: </p>	
<p>VAS 155.740 FPM 2x 136.940 9400956489 FPM 16x</p>	<p>156.770 9400349129 </p>	<p>AAS 540.540 </p>	<p>a) 030.793 Dirko HT</p> <p>b) 877.950 incl. 813.036 M 14x1,25x13</p> <p>b) 813.036 9400313279 CU C 14x20x2</p>	<p>K:← 393.990 9614194980 ASW RD PTFE/ACM 42x62x7</p> <p>K:→ 394.012 ASW LD PTFE/ACM 90x110x8</p> <p>N:← 153.740 9400807289 ASW RD FPM 27x47x7</p>	<p>TLS 714.640 </p>
<p>VAS 155.740 FPM 2x 136.940 9400956489 FPM 16x</p>	<p>156.770 9400349129 </p>		<p>a) 030.793 Dirko HT</p> <p>b) 877.950 incl. 813.036 M 14x1,25x13</p> <p>b) 813.036 9400313279 CU C 14x20x2</p>	<p>K:← 508.233 9614194980 ASW RD FPM/ACM 42x62x7</p> <p>K:→ 508.209 9614379380 ASW LD FPM/ACM 90x110x7</p> <p>N:← 153.740 9400807289 ASW RD FPM 27x47x7</p>	<p>TLS 714.610 </p>







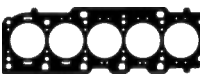



<p>FIAT</p> 				
<p>DW10BTED4 RHK RHR</p> <p>4 Cyl. 1997 ccm Cyl. 85,0 Ø</p> <p>Scudo Multijet 01/2007 →</p> <p>Ulysse Multijet 05/2006 → 06/2011</p>	<p>S⊕* 527.660</p>   <p>ES⊕ 527.550</p>  	<p>135.052 9644450580</p>  <p>0,550 mm → 0,600 mm</p> <p>1,25 mm $\frac{\pm}{\pm}$ 86 Ø 1 ⊗</p> <p>153.002 9644450680</p>  <p>0,610 mm → 0,650 mm</p> <p>1,30 mm $\frac{\pm}{\pm}$ 86 Ø 2 ⊗</p> <p>153.142 9644450780</p>  <p>0,660 mm → 0,710 mm</p> <p>1,35 mm $\frac{\pm}{\pm}$ 86 Ø 3 ⊗</p> <p>135.072 9644050880</p>  <p>0,710 mm → 0,750 mm</p> <p>1,40 mm $\frac{\pm}{\pm}$ 86 Ø 4 ⊗</p>	<p>ZKS 267.551 9646397880 (10x) M 12x1,5x121</p> 	<p>ZKHS 540.540</p> 







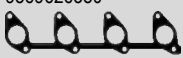
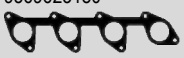

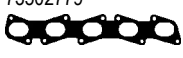
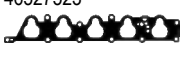

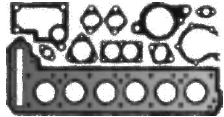
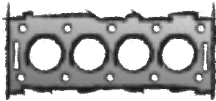

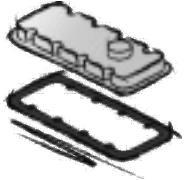

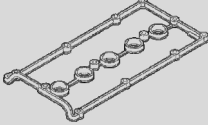

			<p>a) </p> <p>b) </p>	<p>K: </p> <p>N: </p>	
<p>VAS 155.740 FPM 2x 136.940 9400956489 FPM 16x</p>	<p>156.770 9400349129 </p>	<p>AAS 540.540 </p>	<p>a) 030.793 Dirko HT</p> <p>b) 877.950 incl. 813.036 M 14x1,25x13</p> <p>b) 813.036 9400313279 CU C 14x20x2</p>	<p>K:← 393.990 9614194980 ASW RD PTFE/ACM 42x62x7</p> <p>K:→ 394.012 ASW LD PTFE/ACM 90x110x8</p> <p>N:← 153.740 9400807289 ASW RD FPM 27x47x7</p>	<p>TLS 714.640 </p>



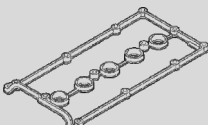

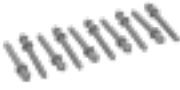



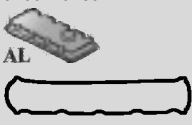









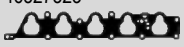

<p>FIAT</p> 				
<p>RHV</p> <p>4 Cyl. 1997 ccm Cyl. 85,0 Ø</p> <p>Ducato JTD 07/2001 →</p>	<p>S⊕* 449.471</p>  <p>ES⊕ 851.361</p>  <p>CS* 851.292</p>	<p>075.820 9635967180  0,470 mm → 0,605 mm 1,30 mm $\frac{\pm}{\pm}$ 86 Ø 1 ▽</p> <p>075.830 9635967280  0,605 mm → 0,655 mm 1,35 mm $\frac{\pm}{\pm}$ 86 Ø 2 ▽</p> <p>075.840 9635967380  0,655 mm → 0,705 mm 1,40 mm $\frac{\pm}{\pm}$ 86 Ø 3 ▽</p> <p>075.850 9635967480  0,705 mm → 0,755 mm 1,45 mm $\frac{\pm}{\pm}$ 86 Ø 4 ▽</p> <p>075.860 9635967580  0,755 mm → 0,830 mm 1,50 mm $\frac{\pm}{\pm}$ 86 Ø 5 ▽</p> <p>075.870 1,55 mm $\frac{\pm}{\pm}$ 86 Ø ▽▽▽</p> <p>075.880 1,60 mm $\frac{\pm}{\pm}$ 86 Ø ▽▽▽▽</p> <p>075.890 1,65 mm $\frac{\pm}{\pm}$ 86 Ø ▽▽▽▽▽</p>	<p>ZKS 267.551 9646397880 (10x) M 12x1,5x121</p> 	<p>851.560 9630142380</p> 











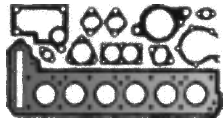
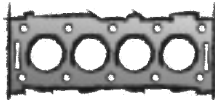

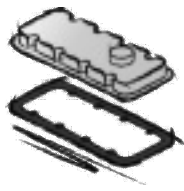
			<p>a) </p> <p>b) </p>	<p>K: </p> <p>N: </p>	
<p>VAS 155.740 FPM 136.940 9400956489 FPM 8x</p>	<p>044.611 9569626380 </p>	<p>851.550 9569623180 </p>	<p>a) 030.793 Dirko HT</p> <p>b) 877.950 incl. 813.036 M 14x1,25x13</p> <p>b) 813.036 9400313279 CU C 14x20x2</p>	<p>K:← 508.233 9614194980 ASW RD FPM/ACM 42x62x7</p> <p>K:→ 508.209 9614379380 ASW LD FPM/ACM 90x110x7</p> <p>N:← 153.740 9400807289 ASW RD FPM 27x47x7</p>	<p>TLS 714.620 </p>





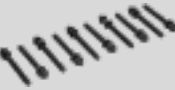
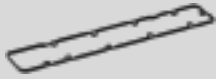
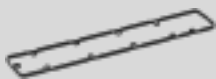

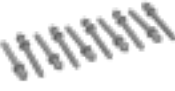



<p>FIAT</p> 				
<p>RHX RHZ</p> <p>4 Cyl. 1997 ccm Cyl. 85,0 Ø</p> <p>Scudo JTD 10/1999 → 12/2006</p> <p>Ulysse JTD 10/1999 → 08/2002</p>	<p>S⊕* 449.471 </p> <p>ES⊕ 851.361 </p> <p>CS* 851.292</p>	<p>075.820 9635967180  0,470 mm → 0,605 mm 1,30 mm $\frac{\pm}{\pm}$ 86 Ø 1 ▽</p> <p>075.830 9635967280  0,605 mm → 0,655 mm 1,35 mm $\frac{\pm}{\pm}$ 86 Ø 2 ▽</p> <p>075.840 9635967380  0,655 mm → 0,705 mm 1,40 mm $\frac{\pm}{\pm}$ 86 Ø 3 ▽</p> <p>075.850 9635967480  0,705 mm → 0,755 mm 1,45 mm $\frac{\pm}{\pm}$ 86 Ø 4 ▽</p> <p>075.860 9635967580  0,755 mm → 0,830 mm 1,50 mm $\frac{\pm}{\pm}$ 86 Ø 5 ▽</p> <p>075.870 1,55 mm $\frac{\pm}{\pm}$ 86 Ø ▽▽▽</p> <p>075.880 1,60 mm $\frac{\pm}{\pm}$ 86 Ø ▽▽▽▽</p> <p>075.890 1,65 mm $\frac{\pm}{\pm}$ 86 Ø ▽▽▽▽▽</p>	<p>ZKS 267.551 9646397880 (10x) M 12x1,5x121</p> 	<p>851.560 9630142380</p> 
<p>175 A3.000</p> <p>5 Cyl. 1998 ccm Cyl. 82,0 Ø</p> <p>Coupé Turbo 08/1996 → 08/2000</p>	<p>S⊕* 180.630 71711518</p> <p>ES⊕ 180.640 71711517</p>	<p>184.742 55192551 1,65 mm $\frac{\pm}{\pm}$ 83 Ø</p> 	<p>ZKS 152.090 7710582 (12x) M 10x1,25x254</p> 	<p>ZKHS 199.100 7766236</p> 

			<p>a) </p> <p>b) </p>	<p>K: </p> <p>N: </p>	
<p>VAS 155.740 FPM 136.940 9400956489 FPM 8x</p>	<p>044.611 9569626380 </p>	<p>851.550 9569623180 </p>	<p>a) 030.793 Dirko HT</p> <p>b) 877.930 incl. 108.502 M 10x1,25x13</p> <p>b) 877.950 incl. 813.036 M 14x1,25x13</p> <p>b) 108.502 9400313409 CU A 10x21x2,1</p> <p>b) 813.036 9400313279 CU C 14x20x2</p>	<p>K:← 508.233 9614194980 ASW RD FPM/ACM 42x62x7</p> <p>K:→ 508.209 9614379380 ASW LD FPM/ACM 90x110x7</p> <p>N:← 153.740 9400807289 ASW RD FPM 27x47x7</p>	<p>TLS 714.610 </p>
<p>701.289 46436047 FPM 20x</p>	<p>725.850 73502779 </p>	<p>725.840 46527523 </p>	<p>a) 030.793 Dirko HT</p> <p>b) 877.920 incl. 339.580 46476967 M 18x1,5x22</p> <p>b) 339.580 55196309 CU A 18x26x1,5</p>	<p>K:← 069.590 7628850 AW/BS RD FPM 31x41x7</p> <p>K:→ 199.191 71718365 SP LD FPM 93x12</p> <p>N:← 477.010 60603436 AW/BS RD FPM 55x68x8</p> <p>N:← 505.838 60809849 ASW RD FPM 30x42x7</p>	

<p>FIAT</p> 				
<p>182 B3.000 182 B7.000</p> <p>5 Cyl. 1998 ccm Cyl. 82,0 Ø</p> <p>Bravo 07/1998 → 10/2001</p> <p>Coupé 04/1998 → 08/2000</p> <p>Marea 04/1999 → 02/2003</p>	<p>S⊕* 198.950 71713676</p>	<p>710.520 7766268</p>  <p>83 Ø</p>	<p>ZKS 152.090 7710582 (12x) M 10x1,25x254</p> 	<p>199.110 46464114</p> 
<p>182 A1.000 185 A5.011</p> <p>5 Cyl. 1998 ccm Cyl. 82,0 Ø</p> <p>Bravo 10/1995 → 07/1998</p> <p>Coupé 08/1996 → 09/1998</p> <p>Marea 09/1996 → 09/2000</p>		<p>710.520 7766268</p>  <p>83 Ø</p>	<p>ZKS 152.090 7710582 (12x) M 10x1,25x254</p> 	<p>ZKHS 199.100 7766236</p> 
<p>185 A8.000</p> <p>5 Cyl. 1998 ccm Cyl. 82,0 Ø</p> <p>Marea 01/2001 → 05/2002</p>	<p>ES⊕ 198.850 71718045</p>	<p>687.346 55189964 0,49 mm $\frac{1}{16}$</p>  <p>84 Ø</p>	<p>ZKS 152.090 7710582 (12x) M 10x1,25x254</p> 	<p>199.110 46464114</p> 
<p>RFL RFW</p> <p>4 Cyl. 1998 ccm Cyl. 86,0 Ø</p> <p>Ducato 03/1994 →</p>	<p>ES⊕ 219.100 CS* 436.540</p>	<p>219.071 9616067680 1,25 mm $\frac{1}{8}$</p>  <p>87 Ø</p>	<p>ZKS 152.550 9633190080 (10x) M 12x1,5x123</p> 	<p>590.932 9400249489</p>  <p>AL</p>
<p>RFU (XU10J2C)</p> <p>4 Cyl. 1998 ccm Cyl. 86,0 Ø</p> <p>Ulysse 06/1994 → 08/2002</p>	<p>ES⊕ 219.170 CS* 436.540</p>	<p>219.071 9616067680 1,25 mm $\frac{1}{8}$</p>  <p>87 Ø</p>	<p>ZKS 152.550 9633190080 (10x) M 12x1,5x123</p> 	<p>590.932 9400249489</p>  <p>AL</p>

			<p>a) </p> <p>b) </p>	<p>K: </p> <p>N: </p>	
<p>701.289 46436047 FPM 20x</p>	<p>725.850 73502779</p> 	<p>725.840 46527523</p> 	<p>a) 030.793 Dirko HT</p> <p>b) 877.920 incl. 339.580 46476967 M 18x1,5x22</p> <p>b) 339.580 55196309 CU A 18x26x1,5</p>	<p>K:← 069.590 7628850 AW/BS RD FPM 31x41x7</p> <p>K:→ 199.191 71718365 SP LD FPM 93x12</p> <p>N:← 477.010 60603436 AW/BS RD FPM 55x68x8</p> <p>N:← 505.838 60809849 ASW RD FPM 30x42x7</p>	
<p>701.289 46436047 FPM 20x</p>	<p>725.850 73502779</p> 	<p>725.840 46527523</p> 	<p>a) 030.793 Dirko HT</p> <p>b) 877.920 incl. 339.580 46476967 M 18x1,5x22</p> <p>b) 339.580 55196309 CU A 18x26x1,5</p>	<p>K:← 069.590 7628850 AW/BS RD FPM 31x41x7</p> <p>K:→ 199.191 71718365 SP LD FPM 93x12</p> <p>N:← 477.010 60603436 AW/BS RD FPM 55x68x8</p> <p>N:← 505.838 60809849 ASW RD FPM 30x42x7</p>	
<p>701.289 46436047 FPM 20x</p>	<p>725.850 73502779</p> 	<p>725.840 46527523</p> 	<p>a) 030.793 Dirko HT</p> <p>b) 877.920 incl. 339.580 46476967 M 18x1,5x22</p> <p>b) 339.580 55196309 CU A 18x26x1,5</p>	<p>K:← 069.590 7628850 AW/BS RD FPM 31x41x7</p> <p>K:→ 199.191 71718365 SP LD FPM 93x12</p> <p>N:← 477.010 60603436 AW/BS RD FPM 55x68x8</p> <p>N:← 505.838 60809849 ASW RD FPM 30x42x7</p>	
<p>VAS 294.250 FPM 294.110 7553637 FPM 8x</p>	<p>590.959 9400349709 4x</p> 	<p>023.540 2x</p>  <p>023.680 5894954 2x</p> 	<p>a) 590.984</p>  <p>b) 877.950 incl. 813.036 M 14x1,25x13</p> <p>b) 813.036 9400313279 CU C 14x20x2</p>	<p>K:← 508.233 9614194980 ASW RD FPM/ACM 42x62x7</p> <p>K:→ 508.209 9614379380 ASW LD FPM/ACM 90x110x7</p> <p>N:← 505.366 9653528780 9400236499 ASW RD FPM/ACM 36x50x7</p>	
<p>VAS 294.250 FPM 294.110 7553637 FPM 8x</p>	<p>590.959 9400349709 4x</p> 	<p>505.020 9569138780 2x</p> 	<p>a) 590.984</p>  <p>b) 877.950 incl. 813.036 M 14x1,25x13</p> <p>b) 813.036 9400313279 CU C 14x20x2</p>	<p>K:← 508.233 9614194980 ASW RD FPM/ACM 42x62x7</p> <p>K:→ 508.209 9614379380 ASW LD FPM/ACM 90x110x7</p> <p>N:← 505.366 9653528780 9400236499 ASW RD FPM/ACM 36x50x7</p>	

<p>FIAT</p> 				
<p>RFV 4 Cyl. 1998 ccm Cyl. 86,0 Ø</p> <p>Ulysse 05/1998 → 09/2000</p>	<p>S⊕* 872.250 09/1998 → </p> <p>ES⊕ 182.020 →08/1998 </p> <p>ES⊕ 182.050 09/1998 → </p> <p>CS* 258.760</p>	<p>851.091 9616818580 1,15 mm $\frac{\pm}{\pm}$ 87 Ø </p> <p>183.411 9629100980 1,35 mm $\frac{\pm}{\pm}$ 87 Ø </p>	<p>ZKS 129.900 9605999480 (10x) M 12x1,5x110</p> 	<p>152.307 9463330280 E</p>  <p>152.317 9463331080 A</p> 
<p>RGX (XU10J2CTE) 4 Cyl. 1998 ccm Cyl. 86,0 Ø</p> <p>Ulysse Turbo 06/1994 → 08/2002</p>	<p>CS* 436.540</p>	<p>331.740 9619659980 1,20 mm $\frac{\pm}{\pm}$ 87 Ø </p>	<p>ZKS 152.550 9633190080 (10x) M 12x1,5x123</p> 	<p>590.932 9400249489</p>  <p>AL</p> 

			<p>a) </p> <p>b) </p>	<p>K: </p> <p>N: </p>	
<p>VAS 155.720 FPM →08/1998</p> <p>VAS 155.750 FPM 08/1998→</p> <p>090.970 9400956480 FPM →08/1998 16x</p> <p>149.360 9400956459 FPM 09/1998→ 16x</p>	<p>076.040 9569136880</p> 	<p>181.340 9569108380 4x</p>	<p>a) 030.793 Dirko HT</p> <p>b) 877.950 incl. 813.036 M 14x1,25x13</p> <p>b) 813.036 9400313279 CU C 14x20x2</p>	<p>K:← 508.233 9614194980 ASW RD FPM/ACM 42x62x7</p> <p>K:→ 508.209 9614379380 ASW LD FPM/ACM 90x110x7</p> <p>N:← 505.366 9653528780 9400236499 ASW RD FPM/ACM 36x50x7</p>	
<p>VAS 294.250 FPM</p> <p>294.110 7553637 FPM 8x</p>		<p>505.020 9569138780 2x 11/1997→</p> 	<p>a) 590.984</p>  <p>b) 877.950 incl. 813.036 M 14x1,25x13</p> <p>b) 813.036 9400313279 CU C 14x20x2</p>	<p>K:← 508.233 9614194980 ASW RD FPM/ACM 42x62x7</p> <p>K:→ 508.209 9614379380 ASW LD FPM/ACM 90x110x7</p> <p>N:← 505.366 9653528780 9400236499 ASW RD FPM/ACM 36x50x7</p>	

FIAT

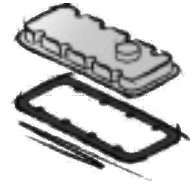
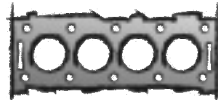
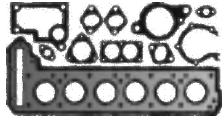

P8C

4 Cyl. 2088 ccm
Cyl. 85,0 Ø

Ulysse TD

03/1996 → 10/1999

ES⊕ 436.581



422.531

9628575980

 0,540 mm
→
0,640 mm
1,35 mm $\frac{\pm}{\pm}$ 86 Ø

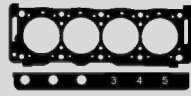

147.001

9620480580

 0,640 mm
→
0,760 mm
1,52 mm $\frac{\pm}{\pm}$ 86 Ø

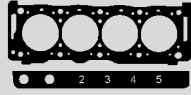

147.011

9620480680

 0,760 mm
→
0,810 mm
1,57 mm $\frac{\pm}{\pm}$ 86 Ø

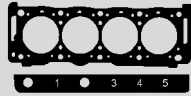

147.021

9620480780

 0,810 mm
→
0,860 mm
1,62 mm $\frac{\pm}{\pm}$ 86 Ø

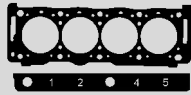

147.031

9620480880

 0,860 mm
→
0,910 mm
1,67 mm $\frac{\pm}{\pm}$ 86 Ø

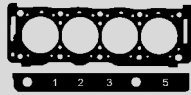

147.041

9620480980

 0,910 mm
→
0,960 mm
1,72 mm $\frac{\pm}{\pm}$ 86 Ø

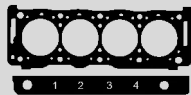

422.551

9628139280

1,77 mm $\frac{\pm}{\pm}$ 86 Ø



ZKS 758.260









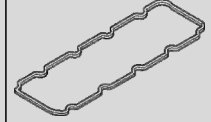

9638586480 (10x)
M 12x1,5x150











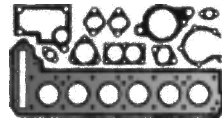
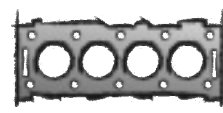

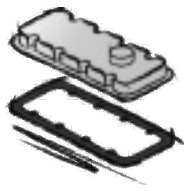













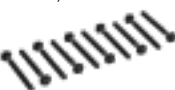
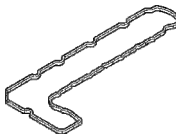



773.950











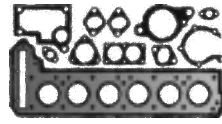
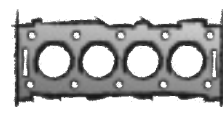

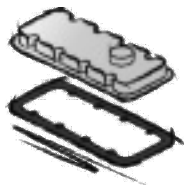

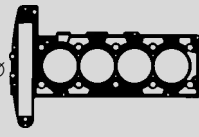



9608064880



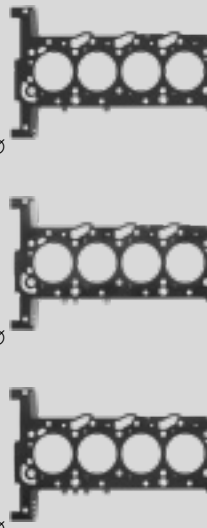

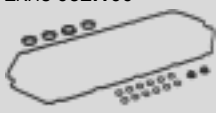

























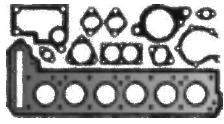
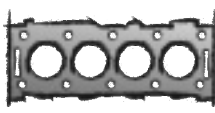

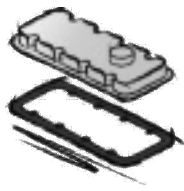











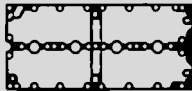

			<p>a) </p> <p>b) </p>	<p>K: </p> <p>N: </p>	
<p>294.110 7553637 FPM 12x</p>	<p>439.760 9569623480</p> 	<p>439.770 9400348969</p> 	<p>a) 590.984</p>  <p>b) 877.950 incl. 813.036 M 14x1,25x13</p> <p>b) 813.036 9400313279 CU C 14x20x2</p>	<p>K:← 508.233 9614194980 ASW RD FPM/ACM 42x62x7</p> <p>K:→ 508.209 9614379380 ASW LD FPM/ACM 90x110x7</p> <p>N:← 302.589 9400236149 A WD FPM 35x50x8</p>	











<p>FIAT</p> 				
<p>4HP 4HR 4HS 4HT (DW12BTED4)</p> <p>4 Cyl. 2179 ccm Cyl. 85,0 Ø</p> <p>Ulysse JTD 03/2008 → 06/2011</p> <p>Ulysse Multijet 03/2008 → 06/2011</p>	<p>ES⊕ 449.600</p>  <p>CS* 729.880</p>	<p>732.160 9687750280</p>  <p>0,550 mm → 0,600 mm</p> <p>1,25 mm $\frac{\pm}{\pm}$ 86 Ø 1 ⊗</p> <p>732.170 9687750380</p>  <p>0,610 mm → 0,650 mm</p> <p>1,30 mm $\frac{\pm}{\pm}$ 86 Ø 2 ⊗</p> <p>732.180 9687750480</p>  <p>0,660 mm → 0,700 mm</p> <p>1,35 mm $\frac{\pm}{\pm}$ 86 Ø 3 ⊗</p> <p>732.190 9687750580</p>  <p>0,710 mm → 0,750 mm</p> <p>1,40 mm $\frac{\pm}{\pm}$ 86 Ø 4 ⊗</p>	<p>ZKS 267.551 9646397880 (10x) M 12x1,5x121</p> 	<p>ZKHS 469.070</p>  <p>790.690 9656742280</p> 
<p>4HW (DW12ATED4)</p> <p>4 Cyl. 2179 ccm Cyl. 85,0 Ø</p> <p>Ulysse JTD 08/2002 → 08/2006</p>	<p>ES⊕ 216.470 9463380080</p>  <p>CS* 449.680</p>	<p>135.052 9644450580</p>  <p>0,550 mm → 0,600 mm</p> <p>1,25 mm $\frac{\pm}{\pm}$ 86 Ø 1 ⊗</p> <p>153.002 9644450680</p>  <p>0,610 mm → 0,650 mm</p> <p>1,30 mm $\frac{\pm}{\pm}$ 86 Ø 2 ⊗</p> <p>153.142 9644450780</p>  <p>0,660 mm → 0,710 mm</p> <p>1,35 mm $\frac{\pm}{\pm}$ 86 Ø 3 ⊗</p> <p>135.072 9644050880</p>  <p>0,710 mm → 0,750 mm</p> <p>1,40 mm $\frac{\pm}{\pm}$ 86 Ø 4 ⊗</p>	<p>ZKS 267.551 9646397880 (10x) M 12x1,5x121</p> 	<p>154.170 9463380380</p> 







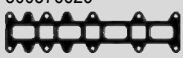
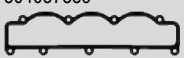
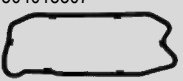

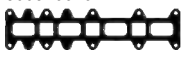
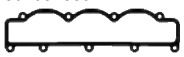
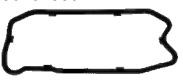

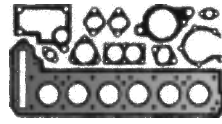
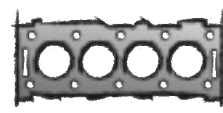

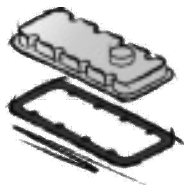









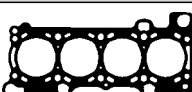

			<p>a) </p> <p>b) </p>	<p>K: </p> <p>N: </p>	
<p>VAS 453.750 FPM</p>	<p>901.840 </p>	<p>AAS 469.080 9661413780 </p>	<p>a) 036.164 Dirko HT / EU</p> <p>a) 510.031 Dirko HT / USA/CDN/MEX</p> <p>a) 527.291 Dirko HT / RU</p> <p>a) 648.661 Dirko HT / BR</p> <p>b) 877.930 incl. 108.502 M 10x1,25x13</p> <p>b) 108.502 9400313409 CU A 10x21x2,1</p>	<p>K:← 393.990 9614194980 ASW RD PTFE/ACM 42x62x7</p> <p>K:→ 394.012 ASW LD PTFE/ACM 90x110x8</p> <p>N:← 153.740 9400807289 ASW RD FPM 27x47x7</p>	
<p>VAS 155.740 FPM 2x</p> <p>136.940 9400956489 FPM 16x</p>	<p>156.770 9400349129 </p>		<p>a) 036.164 Dirko HT / EU</p> <p>a) 510.031 Dirko HT / USA/CDN/MEX</p> <p>a) 527.291 Dirko HT / RU</p> <p>a) 648.661 Dirko HT / BR</p> <p>b) 877.950 incl. 813.036 M 14x1,25x13</p> <p>b) 813.036 9400313279 CU C 14x20x2</p>	<p>K:← 508.233 9614194980 ASW RD FPM/ACM 42x62x7</p> <p>K:→ 508.209 9614379380 ASW LD FPM/ACM 90x110x7</p> <p>N:← 153.740 9400807289 ASW RD FPM 27x47x7</p>	<p>TLS 745.120 </p>



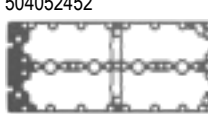





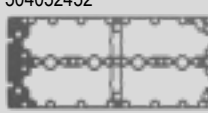







<p>FIAT</p> 				
<p>194 A1.000 4 Cyl. 2198 ccm Cyl. 86,0 Ø</p> <p>Croma 06/2005 →</p>	<p>ES⊕ 081.500 71739402  PLASTIC</p> <p>CS* 382.130</p>	<p>807.801 71739387 0,50 mm $\frac{\pm}{\pm}$ 87,3 Ø</p> 	<p>ZKS 257.910 71739374 (10x) M 11x1,5x162</p>  <p>ZKS 509.710 M 11x1,5x162 / M 8</p> 	<p>ZKHS 428.750 ●</p>  PLASTIC
<p>4HJ (PUMA C) 4 Cyl. 2198 ccm Cyl. 86,0 Ø</p>				<p>469.690 ↑ 2x</p>
<p>4HU (P22DTE) 4HV 4 Cyl. 2198 ccm Cyl. 86,0 Ø</p> <p>Ducato Multijet 07/2006 →</p>	<p>S⊕ 867.800 </p> <p>ES⊕ 429.170 </p> <p>CS* 437.370</p>	<p>156.201 9649197480  0,430 mm → 0,520 mm 1,10 mm $\frac{\pm}{\pm}$ 87,1 Ø 1 ▽</p> <p>156.211 9660534980  0,521 mm → 0,570 mm 1,15 mm $\frac{\pm}{\pm}$ 87,1 Ø 2 ▽</p> <p>156.221 9660535080  0,571 mm → 0,620 mm 1,20 mm $\frac{\pm}{\pm}$ 87,1 Ø 3 ▽</p> 	<p>ZKS 733.100 9659281480 (8x) +9659135580 (10x) M 10x1,5x140 8x1,25x121</p> 	<p>ZKHS 052.100</p>  ↑ 2x  173.700 ↑ 2x <p>027.720 9662221680</p>  177.700 9662222180 4x  389.140 12x

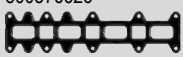
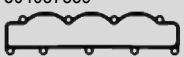
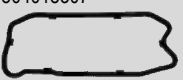





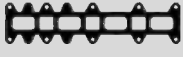



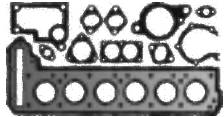
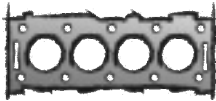

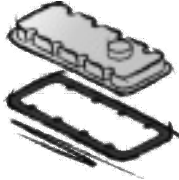

			<p>a) </p> <p>b) </p>	<p>K: </p> <p>N: </p>	
<p>VAS 538.080 FPM 007.030 71739347 FPM 16x</p> 	<p>124.372 71739214</p> 	<p>AAS 007.051 71739202</p> 	<p>a) 030.793 Dirko HT</p> <p>b) 823.400 M 12x1,75x17</p> <p>b) 056.130 71739194 FPM RD 10,8x20,8x2,6</p>	<p>K:← 127.610 71739386 ASW RD FPM/ACM 42x55x7</p> <p>K:← 595.170 AW/BS OF RD FPM 42x55x7</p> <p>K:→ 694.770 71739336 ASW LD FPM/ACM 90x104x11</p>	
<p>027.740 9660039680 FPM 16x</p> 	<p>392.440 9661331880</p> 	<p>AAS 280.350 9660148080</p>  <p>027.150 9661743180 8x</p> 	<p>a) OWS 027.371 9660148080</p>  <p>a) 036.164 Dirko HT / EU ↓</p> <p>a) 510.031 Dirko HT / USA/CDN/MEX ↓</p> <p>a) 527.291 Dirko HT / RU ↓</p> <p>a) 648.661 Dirko HT / BR ↓</p> <p>b) 012.001 9659107280 M 14x1,5x20</p> <p>b) 176.090 13x22,4x3</p>	<p>K:← 026.782 9659901780 ASW RD PTFE 50x90x14</p> <p>K:→ 026.812 9659337480 IWD LD PTFE/ACM 106x215</p>	<p>TLS 430.140</p> 

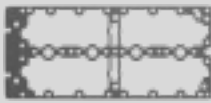



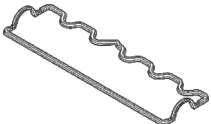



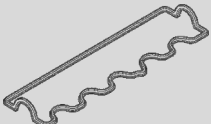







<p>FIAT</p> 				
<p>F1AE0481C</p> <p>4 Cyl. 2287 ccm Cyl. 88,0 Ø</p> <p>Ducato JTD 04/2002 →</p>	<p>S* 332.691 →Mot. 133428</p>  <p>S* 733.541 ● Mot. 133429→</p>  <p>S⊕* 733.542 Mot. 133429→</p>  <p>ES⊕ 452.700 500055000</p> <p>ES⊕ 651.930</p>  <p>ES⊕ 431.500 504049362 →Mot. 133428</p>  <p>ES⊕ 733.530 ● 2995609 Mot. 133429→</p> 	<p>389.430 500387067</p>  <p> 0,300 mm → 0,400 mm 1,10 mm $\frac{2}{3}$ 88,5 Ø</p> <p>389.440 500387068</p>  <p> 0,400 mm → 0,500 mm 1,20 mm $\frac{2}{3}$ 88,5 Ø</p> <p>389.450 500387069</p>  <p> 0,500 mm → 0,600 mm 1,30 mm $\frac{2}{3}$ 88,5 Ø</p>	<p>ZKS 464.390</p>	<p>431.620 504019494 →Mot. 133428</p>  <p>718.220 504052452 Mot. 133429→</p>  <p>452.640 504239811 4x</p>
<p>F1AE0481D/N</p> <p>4 Cyl. 2287 ccm Cyl. 88,0 Ø</p> <p>Ducato Multijet 07/2006 →</p>	<p>S* 733.541 ●</p>  <p>S⊕* 733.542</p>  <p>ES⊕ 452.700 500055000</p> <p>ES⊕ 651.930</p>  <p>ES⊕ 733.530 ● 2995609</p> 	<p>389.430 500387067</p>  <p> 0,300 mm → 0,400 mm 1,10 mm $\frac{2}{3}$ 88,5 Ø</p> <p>389.440 500387068</p>  <p> 0,400 mm → 0,500 mm 1,20 mm $\frac{2}{3}$ 88,5 Ø</p> <p>389.450 500387069</p>  <p> 0,500 mm → 0,600 mm 1,30 mm $\frac{2}{3}$ 88,5 Ø</p>	<p>ZKS 464.390</p>	<p>718.220 504052452</p>  <p>452.640 504239811 4x</p>







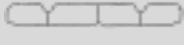

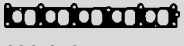
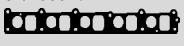

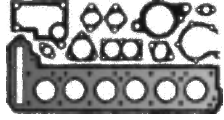
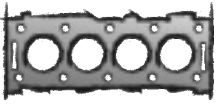



			<p>a) </p> <p>b) </p>	<p>K: </p> <p>N: </p>	
<p>718.210 500395378 FPM 16x</p> 	<p>722.140 500376626</p> 	<p>718.680 504037859</p> 	<p>a) 505.450 504018307</p>  <p>b) 877.910 M 22x1,5x10</p> <p>b) 128.503 16508460 CU A 22x27x1,5</p>	<p>K:← 431.110 504014155 SP RD FVMQ 50x80x14</p> <p>K:← 749.250 504087648 SP RD PTFE 50x80x11</p> <p>K:→ 431.120 504010779 SP LD FPM 83x113x14</p> <p>N:← 375.470 500350049 A/BS RD FPM 34x60x10</p>	
<p>718.210 500395378 FPM 16x</p> 	<p>722.140 500376626</p> 	<p>718.680 504037859</p> 	<p>a) 505.450 504018307</p>  <p>b) 877.910 M 22x1,5x10</p> <p>b) 128.503 16508460 CU A 22x27x1,5</p>	<p>K:← 431.110 504014155 SP RD FVMQ 50x80x14</p> <p>K:← 749.250 504087648 SP RD PTFE 50x80x11</p> <p>K:→ 431.120 504010779 SP LD FPM 83x113x14</p> <p>N:← 375.470 500350049 A/BS RD FPM 34x60x10</p>	



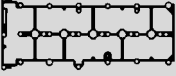
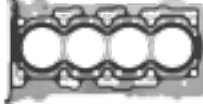
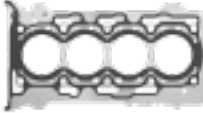
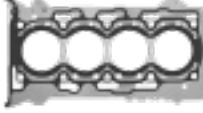











<p>FIAT</p> 				
<p>F1AE0481T</p> <p>4 Cyl. 2287 ccm Cyl. 88,0 Ø</p> <p>Ducato JTD 09/2009 →</p>	<p>ES⊕ 452.700 500055000</p> <p>ES⊕ 651.930</p>  <p>ES⊕ 733.530 ● 2995609</p> 	<p>389.430 500387067</p>  <p>0,300 mm → 0,400 mm</p> <p>1,10 mm $\frac{+}{-}$ 88,5 Ø</p>  <p>389.440 500387068</p>  <p>0,400 mm → 0,500 mm</p> <p>1,20 mm $\frac{+}{-}$ 88,5 Ø</p>  <p>389.450 500387069</p>  <p>0,500 mm → 0,600 mm</p> <p>1,30 mm $\frac{+}{-}$ 88,5 Ø</p> 	<p>ZKS 464.390</p>	<p>718.220 504052452</p>  <p>452.640 504239811 4x</p>
<p>F1AE3481D</p> <p>4 Cyl. 2287 ccm Cyl. 88,0 Ø</p> <p>Ducato Multijet 07/2006 →</p>	<p>ES⊕ 452.700 500055000</p> <p>ES⊕ 651.930</p>  <p>ES⊕ 733.530 ● 2995609</p> 	<p>389.430 500387067</p>  <p>0,300 mm → 0,400 mm</p> <p>1,10 mm $\frac{+}{-}$ 88,5 Ø</p>  <p>389.440 500387068</p>  <p>0,400 mm → 0,500 mm</p> <p>1,20 mm $\frac{+}{-}$ 88,5 Ø</p>  <p>389.450 500387069</p>  <p>0,500 mm → 0,600 mm</p> <p>1,30 mm $\frac{+}{-}$ 88,5 Ø</p> 	<p>ZKS 464.390</p>	<p>718.220 504052452</p>  <p>452.640 504239811 4x</p>
<p>F1AE3481E/G</p> <p>4 Cyl. 2287 ccm Cyl. 88,0 Ø</p> <p>Ducato Multijet 08/2006 →</p>		<p>389.430 500387067</p>  <p>0,300 mm → 0,400 mm</p> <p>1,10 mm $\frac{+}{-}$ 88,5 Ø</p>  <p>389.440 500387068</p>  <p>0,400 mm → 0,500 mm</p> <p>1,20 mm $\frac{+}{-}$ 88,5 Ø</p>  <p>389.450 500387069</p>  <p>0,500 mm → 0,600 mm</p> <p>1,30 mm $\frac{+}{-}$ 88,5 Ø</p> 	<p>ZKS 464.390</p>	<p>718.220 504052452</p>  <p>452.640 504239811 4x</p>



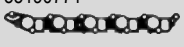







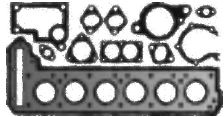
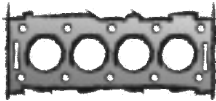

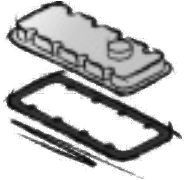

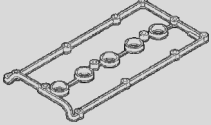
			<p>a) </p> <p>b) </p>	<p>K: </p> <p>N: </p>	
<p>718.210 500395378 FPM 16x</p> 	<p>722.140 500376626</p> 	<p>718.680 504037859</p> 	<p>a) 505.450 504018307</p>  <p>b) 877.910 M 22x1,5x10</p> <p>b) 128.503 16508460 CU A 22x27x1,5</p>	<p>K:← 431.110 504014155 SP RD FVMQ 50x80x14</p> <p>K:← 749.250 504087648 SP RD PTFE 50x80x11</p> <p>K:→ 431.120 504010779 SP LD FPM 83x113x14</p> <p>N:← 375.470 500350049 A/BS RD FPM 34x60x10</p>	
<p>718.210 500395378 FPM 16x</p> 	<p>722.140 500376626</p> 	<p>384.640</p>  <p>718.680 504037859</p> 	<p>a) 505.450 504018307</p>  <p>b) 877.910 M 22x1,5x10</p> <p>b) 128.503 16508460 CU A 22x27x1,5</p>	<p>K:← 431.110 504014155 SP RD FVMQ 50x80x14</p> <p>K:← 749.250 504087648 SP RD PTFE 50x80x11</p> <p>K:→ 431.120 504010779 SP LD FPM 83x113x14</p> <p>N:← 375.470 500350049 A/BS RD FPM 34x60x10</p>	
<p>718.210 500395378 FPM 16x</p> 	<p>722.140 500376626</p> 	<p>384.640</p> 	<p>a) 505.450 504018307</p>  <p>b) 877.910 M 22x1,5x10</p> <p>b) 128.503 16508460 CU A 22x27x1,5</p>	<p>K:← 431.110 504014155 SP RD FVMQ 50x80x14</p> <p>K:← 749.250 504087648 SP RD PTFE 50x80x11</p> <p>K:→ 431.120 504010779 SP LD FPM 83x113x14</p> <p>N:← 375.470 500350049 A/BS RD FPM 34x60x10</p>	









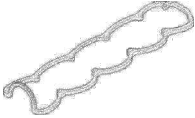









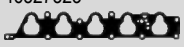

FIAT 				
F1AGL4111-4114 F1AGL411A-D 4 Cyl. 2287 ccm Cyl. 88,0 Ø Ducato Multijet 07/2006 →	ES⊕ 452.700 500055000 ES⊕ 651.930 	389.430 500387067  0,300 mm → 0,400 mm 1,10 mm $\frac{\pm}{\pm}$ 88,5 Ø 389.440 500387068  0,400 mm → 0,500 mm 1,20 mm $\frac{\pm}{\pm}$ 88,5 Ø 389.450 500387069  0,500 mm → 0,600 mm 1,30 mm $\frac{\pm}{\pm}$ 88,5 Ø	ZKS 464.390	718.220 504052452  452.640 504239811 4x
ED3 4 Cyl. 2360 ccm Cyl. 88,0 Ø Freemont 08/2011 →	ES⊕ 448.390 CS* 528.970 CS* 656.420	448.440 0,50 mm $\frac{\pm}{\pm}$ 89 Ø	ZKS 657.030 M 11x1,5x165 	ZKHS 464.280
EDG 4 Cyl. 2360 ccm Cyl. 88,0 Ø Freemont 08/2011 →	CS* 528.970 CS* 656.420	448.440 0,50 mm $\frac{\pm}{\pm}$ 89 Ø	ZKS 657.030 M 11x1,5x165 	ZKHS 464.280
185 A2.000 5 Cyl. 2387 ccm Cyl. 82,0 Ø Marea TD 09/1996 → 04/1999		187.690 ● 46468414 1,70 mm $\frac{\pm}{\pm}$ 83 Ø 1 ⊗ 187.710 46461885 1,80 mm $\frac{\pm}{\pm}$ 83 Ø 2 ⊗	ZKS 152.760 7775920 (12x) M 12x1,25x218 	375.170 7708317 
185 A6.000 839 A5.000 5 Cyl. 2387 ccm Cyl. 82,0 Ø Marea JTD 04/1999 → 05/2002	S⊕* 180.650 ● 71717835 +7735415  ES⊕ 180.730 71717836 +7735415 	184.921 60814966 1,60 mm $\frac{\pm}{\pm}$ 83 Ø 184.951 60814967 1,70 mm $\frac{\pm}{\pm}$ 83 Ø 1 ⊗ 184.931 60814968 1,80 mm $\frac{\pm}{\pm}$ 83 Ø 2 ⊗	ZKS 152.760 7775920 (12x) M 12x1,25x218 	199.050 60814925 











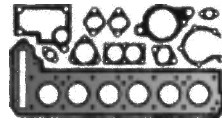
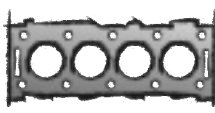

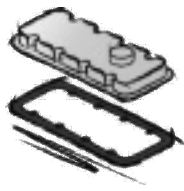



			<p>a) </p> <p>b) </p>	<p>K: </p> <p>N: </p>	
<p>718.210 500395378 FPM 16x</p> 	<p>722.140 500376626</p> 	<p>384.640</p> 	<p>a) 505.450 504018307</p>  <p>b) 877.910 M 22x1,5x10</p> <p>b) 128.503 16508460 CU A 22x27x1,5</p>	<p>K:← 749.250 504087648 SP RD PTFE 50x80x11</p> <p>K:→ 431.120 504010779 SP LD FPM 83x113x14</p> <p>N:← 375.470 500350049 A/BS RD FPM 34x60x10</p>	
<p>429.320 K2222425000 FPM 16x</p>	<p>428.210 K1555A185</p> 	<p>464.050</p> 	<p>a) 036.164 Dirko HT / EU</p> <p>a) 510.031 Dirko HT / USA/CDN/MEX</p> <p>a) 527.291 Dirko HT / RU</p> <p>a) 648.661 Dirko HT / BR</p> <p>b) 298.480 M 14x1,5x18</p>	<p>K:← 127.610 71739386 ASW RD FPM/ACM 42x55x7</p> <p>K:→ 034.560 K05047167AA AS LD FPM 85x103x8</p>	
<p>429.320 K2222425000 FPM 16x</p>		<p>464.050</p> 	<p>a) 036.164 Dirko HT / EU</p> <p>a) 510.031 Dirko HT / USA/CDN/MEX</p> <p>a) 527.291 Dirko HT / RU</p> <p>a) 648.661 Dirko HT / BR</p> <p>b) 298.480 M 14x1,5x18</p>	<p>K:← 127.610 71739386 ASW RD FPM/ACM 42x55x7</p> <p>K:→ 034.560 K05047167AA AS LD FPM 85x103x8</p>	
<p>294.110 7553637 FPM 10x</p>	<p>689.960 46467746</p> 		<p>a) 030.793 Dirko HT</p> <p>b) 877.920 incl. 339.580 46476967 M 18x1,5x22</p> <p>b) 339.580 55196309 CU A 18x26x1,5</p>	<p>K:← 069.590 7628850 AW/BS RD FPM 31x41x7</p> <p>K:→ 199.191 71718365 SP LD FPM 93x12</p> <p>N:← 505.838 60809849 ASW RD FPM 30x42x7</p>	
<p>294.110 7553637 FPM 10x</p>	<p>689.960 46467746</p> 	<p>690.070 7735415 →01/2000</p>  <p>690.140 46772390 01/2000→</p> 	<p>a) 030.793 Dirko HT</p> <p>b) 877.920 incl. 339.580 46476967 M 18x1,5x22</p> <p>b) 339.580 55196309 CU A 18x26x1,5</p>	<p>K:← 069.590 7628850 AW/BS RD FPM 31x41x7</p> <p>K:→ 199.191 71718365 SP LD FPM 93x12</p> <p>N:← 505.838 60809849 ASW RD FPM 30x42x7</p>	



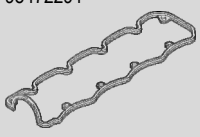





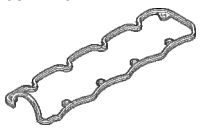









<p>FIAT</p> 				
<p>939 A3.000</p> <p>5 Cyl. 2387 ccm Cyl. 82,0 Ø</p> <p>Croma Multijet 06/2005 →</p>	<p>ES⊕ 356.180 71740961 Mot. 5553218→</p> 	<p>061.151 55184740 0,110 mm → 0,230 mm 0,95 mm $\frac{\pm}{\pm}$ 83 Ø</p>  <p>061.161 55184741 0,231 mm → 0,330 mm 1,05 mm $\frac{\pm}{\pm}$ 83 Ø 1 ⊗</p>  <p>061.171 55184742 0,331 mm → 0,425 mm 1,15 mm $\frac{\pm}{\pm}$ 83 Ø 2 ⊗</p> 	<p>ZKS 497.410 M 12x1,25x224 →08/2007</p> 	<p>375.340 46814175</p> 
<p>4N15</p> <p>4 Cyl. 2442 ccm Cyl. 86,0 Ø</p> <p>Fullback 04/2016 →</p>		<p>468.920 6000605017 1,30 mm $\frac{\pm}{\pm}$ 87,5 Ø 1 ▽</p>  <p>468.870 6000605016 1,35 mm $\frac{\pm}{\pm}$ 87,5 Ø 2 ▽</p>  <p>468.930 6000605018 1,40 mm $\frac{\pm}{\pm}$ 87,5 Ø 3 ▽</p> 		<p>468.850</p> 
<p>8140.61 8140.61.204 8144.61.200 8144.61.500.81</p> <p>4 Cyl. 2445 ccm Cyl. 93,0 Ø</p> <p>Argenta TD 07/1983 → 08/1985</p> <p>Campagnola 06/1974 → 10/1989</p> <p>Ducato 09/1986 → 05/1990</p>	<p>S⊕* 143.300 5892433</p>  <p>ES⊕ 143.291 5892434</p> 	<p>143.280 5891282 1,65 mm $\frac{\pm}{\pm}$ 95,3 Ø centr. 10 mm</p> 	<p>ZKS 760.300 4854648 (10x) +4828150 (12x) M 12x1,25x119/163</p> 	<p>763.071 7302293 Mot. 574799→</p> 











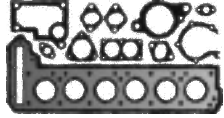
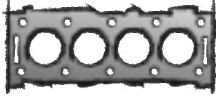

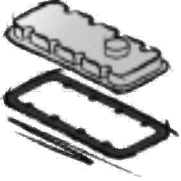

			<p>a) </p> <p>b) </p>	<p>K: </p> <p>N: </p>	
<p>332.330 46743167 FPM →Mot. 5553217 20x</p> <p>506.550 55183812 FPM Mot. 5553218→ 20x</p>	<p>725.850 73502779</p> 	<p>331.230 55190771</p> 	<p>a) 030.793 Dirko HT</p> <p>b) 877.920 incl. 339.580 46476967 M 18x1,5x22</p> <p>b) 339.580 55196309 CU A 18x26x1,5</p>	<p>K:← 069.590 7628850 AW/BS RD FPM 31x41x7</p> <p>K:→ 199.191 71718365 SP LD FPM 93x12</p> <p>N:← 434.500 46802577 A/BS RD FPM 30x45x7</p>	
<p>019.140 FPM E 8x</p> <p>469.350 6000605143 FPM A 8x</p>	<p>477.260</p> 	<p>474.140 6000608401</p>	<p>a) 036.164 Dirko HT / EU</p> <p>a) 510.031 Dirko HT / USA/CDN/MEX</p> <p>a) 527.291 Dirko HT / RU</p> <p>a) 648.661 Dirko HT / BR</p>	<p>K:← 524.890 6000605068 AS RD FPM 70x85x7,5</p> <p>K:→ 524.920 6000605069 AS LD FPM 95x111x8</p>	
<p>VAS 790.860 FPM</p> <p>143.930 40101573 FPM 8x</p>	<p>AAS 898.310 481.300 (4x) +481.320 (4x)</p>  <p>481.320 7300877 4x</p> 	<p>481.300 98425767 4x</p> 	<p>a) 569.670 504017372</p>  <p>a) 890.952 99488483</p>  <p>b) 878.040 incl. 128.503 M 22x1,5x10</p> <p>b) 128.503 16508460 CU A 22x27x1,5</p>	<p>K:← 763.144 98454053 AW/BS RD FPM 70x90x10</p> <p>K:→ 763.136 40100314 ASW LD FPM 90x115x13</p> <p>N:← 419.730 99433965 AW/BS RD FPM 55x70x8</p>	



















<p>FIAT</p> 				
<p>185 A7.011 192 A2.000 192 A7.011</p> <p>5 Cyl. 2446 ccm Cyl. 83,0 Ø</p> <p>Marea 07/2000 → 12/2007</p> <p>Stilo 10/2001 → 08/2008</p>	<p>ES⊕ 198.850 71718045</p>	<p>687.346 55189964 0,49 mm $\frac{1}{4}$ 84 Ø</p> 	<p>ZKS 152.090 7710582 (12x) M 10x1,25x254</p> 	<p>199.110 46464114</p> 
<p>4D56</p> <p>4 Cyl. 2477 ccm Cyl. 91,1 Ø</p> <p>Fullback 04/2016 →</p>	<p>S⊕* 966.260</p> 	<p>940.740 6000605013 1,07 mm $\frac{1}{4}$ 93 Ø</p> <p>940.750 6000605014 1,12 mm $\frac{1}{4}$ 93 Ø</p> <p>940.760 6000605015 1,17 mm $\frac{1}{4}$ 93 Ø</p>		<p>ZKHS 942.790 940.290 6000605051</p> 
<p>8144.97 8144.97.2200/2400</p> <p>4 Cyl. 2499 ccm Cyl. 93,0 Ø</p> <p>Croma TD 05/1989 → 08/1996</p>		<p>143.180 ● 98499876 0,810 mm  → 0,950 mm 1,65 mm $\frac{1}{4}$ 95,3 Ø centr. 12 mm Mot. 1055647→</p> 	<p>ZKS 760.300 4854648 (10x) +4828150 (12x) M 12x1,25x119/163</p> 	
<p>8140.27 8140.27.2100</p> <p>4 Cyl. 2500 ccm Cyl. 93,0 Ø</p> <p>Ducato 09/1986 → 05/1990</p> <p>Ducato TD 09/1986 → 05/1994</p>	<p>S⊕* 143.261 5890738 +99433965 +98451055 +40100341 +40004290</p>  <p>ES⊕ 143.231 5890739 +98454041</p> 	<p>986.496 98410475 1,27 mm $\frac{1}{4}$ 95,3 Ø</p>  <p>986.518 99461499 1,43 mm $\frac{1}{4}$ 95,3 Ø</p> 	<p>ZKS 760.300 4854648 (10x) +4828150 (12x) M 12x1,25x119/163</p> 	<p>763.071 7302293</p> 











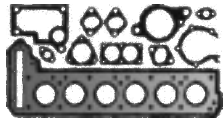
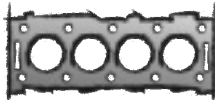

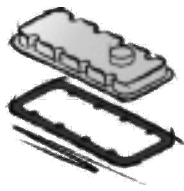











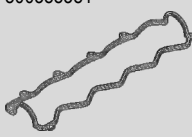

			<p>a) </p> <p>b) </p>	<p>K: </p> <p>N: </p>	
<p>701.289 46436047 FPM 20x</p>	<p>725.850 73502779</p> 	<p>725.840 46527523</p> 	<p>a) 030.793 Dirko HT</p> <p>b) 877.920 incl. 339.580 46476967 M 18x1,5x22</p> <p>b) 339.580 55196309 CU A 18x26x1,5</p>	<p>K:← 069.590 7628850 AW/BS RD FPM 31x41x7</p> <p>K:→ 199.191 71718365 SP LD FPM 93x12</p> <p>N:← 477.010 60603436 AW/BS RD FPM 55x68x8</p> <p>N:← 505.838 60809849 ASW RD FPM 30x42x7</p>	
<p>019.140 FPM 16x</p>	<p>940.580 6000608444</p> 	<p>934.350 6000608404</p>  <p>934.550 6000608403</p> 	<p>a) 858.930 6000608022</p>	<p>K:← 247.280 6000608173 AS RD FPM 44x60x7</p> <p>K:→ 940.640 6000611678 AS LD FPM 91x107x8</p> <p>N:← 293.946 A RD ACM 35x50x8</p>	
<p>VAS 790.860 FPM 143.930 40101573 FPM 8x</p>	<p>AAS 898.310 481.300 (4x) +481.320 (4x)</p>  <p>481.320 7300877 4x</p> 	<p>481.300 98425767 4x</p> 	<p>b) 877.910 M 22x1,5x10</p> <p>b) 128.503 16508460 CU A 22x27x1,5</p>	<p>K:← 419.730 99433965 AW/BS RD FPM 55x70x8</p> <p>K:→ 419.700 98486091 AW/BS LD FPM 100x118x10</p> <p>N:← 419.730 99433965 AW/BS RD FPM 55x70x8</p> <p>N:→ 302.589 9400236149 A WD FPM 35x50x8</p>	
<p>VAS 790.860 FPM 143.930 40101573 FPM 8x</p>	<p>AAS 898.310 481.300 (4x) +481.320 (4x)</p>  <p>481.320 7300877 4x</p> 	<p>481.300 98425767 4x</p> 	<p>a) OWS 290.910 9943 2807 +9943 2808</p>  <p>a) 569.670 504017372</p>  <p>a) 890.952 99488483</p>  <p>b) 877.910 M 22x1,5x10</p> <p>b) 878.040 incl. 128.503 M 22x1,5x10</p> <p>b) 128.503 16508460 CU A 22x27x1,5</p>	<p>K:← 763.144 98454053 AW/BS RD FPM 70x90x10</p> <p>K:→ 419.700 98486091 AW/BS LD FPM 100x118x10</p> <p>N:← 419.730 99433965 AW/BS RD FPM 55x70x8</p>	



















<p>FIAT</p> 				
<p>8140.47/47R</p> <p>4 Cyl. 2500 ccm Cyl. 93,0 Ø</p> <p>Ducato 11/1994 → 04/1998</p> <p>Ducato TD 06/1994 → 09/2001</p> <p>Ducato TDI 03/1994 → 04/2002</p>	<p>S⊕* 710.320 →Mot. 2122143</p>  <p>S⊕* 125.800 5894788 Mot. 2122144 → →Mot. 2263444</p>  <p>S⊕* 125.850 5896986 Mot. 2263445 →</p>  <p>ES⊕ 710.350 5894789</p>  <p>CS* 862.960 →Mot. 2122143</p> <p>CS* 862.940 Mot. 2122144 → →Mot. 2263444</p> <p>CS* 862.950 Mot. 2263445 →</p>	<p>986.496 98410475 1,27 mm $\frac{1}{2}$ 95,3 Ø</p>  <p>986.518 99461499 1,43 mm $\frac{1}{2}$ 95,3 Ø</p>  <p>863.980 98448817 1,57 mm $\frac{1}{2}$ 95,3 Ø</p> 	<p>ZKS 760.300 4854648 (10x) +4828150 (12x) M 12x1,25x119/163</p> 	<p>081.540 98472291</p> 
<p>8140.67</p> <p>4 Cyl. 2500 ccm Cyl. 93,0 Ø</p> <p>Ducato 03/1994 → 04/2002</p>	<p>S⊕* 710.320 →Mot. 2122143</p>  <p>S⊕* 125.800 5894788 Mot. 2122144 → →Mot. 2263444</p>  <p>S⊕* 125.850 5896986 Mot. 2263445 →</p>  <p>ES⊕ 710.350 5894789</p>  <p>CS* 862.960 →Mot. 2122143</p> <p>CS* 862.940 Mot. 2122144 → →Mot. 2263444</p> <p>CS* 862.950 Mot. 2263445 →</p>	<p>986.305 98492581 1,74 mm $\frac{1}{2}$ centr. 13 mm</p> 	<p>ZKS 760.300 4854648 (10x) +4828150 (12x) M 12x1,25x119/163</p> 	<p>081.540 98472291</p> 





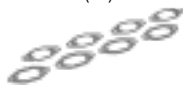





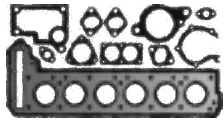
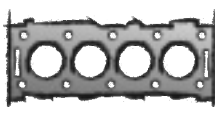

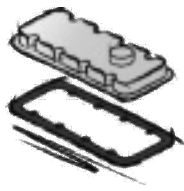











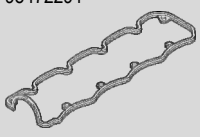

			<p>a) </p> <p>b) </p>	<p>K: </p> <p>N: </p>	
<p>VAS 790.860 FPM 143.930 40101573 FPM 8x</p>	<p>AAS 898.310 481.300 (4x) +481.320 (4x)</p>  <p>481.320 7300877 4x</p> 	<p>481.300 98425767 4x</p> 	<p>a) OWS 290.910 9943 2807 +9943 2808</p>  <p>a) 429.000 500327440</p>  <p>b) 878.040 incl. 128.503 M 22x1,5x10</p> <p>b) 128.503 16508460 CU A 22x27x1,5</p>	<p>K:← 199.220 98461673 IWD RD FPM 70x14</p> <p>K:← 763.144 98454053 AW/BS RD FPM 70x90x10</p> <p>K:→ 199.230 99468744 IWD LD FPM 114x13</p> <p>K:→ 419.700 98486091 AW/BS LD FPM 100x118x10</p> <p>N:← 419.730 99433965 AW/BS RD FPM 55x70x8</p>	<p>TLS 063.110</p> 
<p>VAS 790.860 FPM 143.930 40101573 FPM 8x</p>	<p>AAS 898.310 481.300 (4x) +481.320 (4x)</p>  <p>481.320 7300877 4x</p> 	<p>481.300 98425767 4x</p> 	<p>a) OWS 290.910 9943 2807 +9943 2808</p>  <p>a) 429.000 500327440</p>  <p>b) 878.040 incl. 128.503 M 22x1,5x10</p> <p>b) 128.503 16508460 CU A 22x27x1,5</p>	<p>K:← 199.220 98461673 IWD RD FPM 70x14</p> <p>K:← 763.144 98454053 AW/BS RD FPM 70x90x10</p> <p>K:→ 199.230 99468744 IWD LD FPM 114x13</p> <p>K:→ 419.700 98486091 AW/BS LD FPM 100x118x10</p> <p>N:← 419.730 99433965 AW/BS RD FPM 55x70x8</p>	









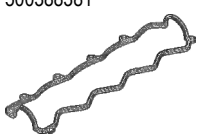









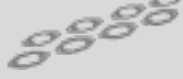

<p>FIAT</p> 				
<p>8144.67</p> <p>4 Cyl. 2500 ccm Cyl. 93,0 Ø</p> <p>Croma 12/1985 → 12/1989</p> <p>Ducato 01/1982 → 05/1994</p>	<p>S⊕* 143.300 5892433</p>  <p>ES⊕ 143.291 5892434</p> 	<p>986.305 98492581 1,74 mm ± centr. 13 mm</p> 	<p>ZKS 760.300 4854648 (10x) +4828150 (12x) M 12x1,25x119/163</p> 	<p>763.071 7302293</p> 
<p>8144.97 S</p> <p>4 Cyl. 2500 ccm Cyl. 93,0 Ø</p> <p>Croma TD 12/1991 → 08/1996</p>		<p>143.180 ● 98499876</p>  <p>0,810 mm → 0,950 mm</p> <p>1,65 mm ± 95,3 Ø centr. 12 mm</p> 	<p>ZKS 760.300 4854648 (10x) +4828150 (12x) M 12x1,25x119/163</p> 	
<p>8144.97 Y</p> <p>4 Cyl. 2500 ccm Cyl. 93,0 Ø</p> <p>Croma TD 05/1989 → 08/1996</p>		<p>143.180 ● 98499876</p>  <p>0,810 mm → 0,950 mm</p> <p>1,65 mm ± 95,3 Ø centr. 12 mm Mot. 1055647→</p> 	<p>ZKS 760.300 4854648 (10x) +4828150 (12x) M 12x1,25x119/163</p> 	











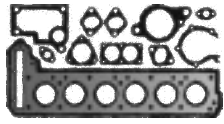
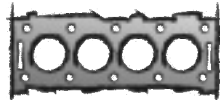

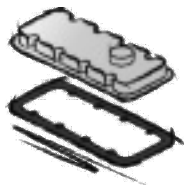



			<p>a) </p> <p>b) </p>	<p>K: </p> <p>N: </p>	
<p>VAS 790.860 FPM 143.930 40101573 FPM 8x</p>	<p>AAS 898.310 481.300 (4x) +481.320 (4x)</p>  <p>481.320 7300877 4x</p> 	<p>481.300 98425767 4x</p> 	<p>a) 569.670 504017372</p>  <p>a) 890.952 99488483</p>  <p>b) 877.910 M 22x1,5x10</p> <p>b) 128.503 16508460 CU A 22x27x1,5</p>	<p>K:← 763.144 98454053 AW/BS RD FPM 70x90x10</p> <p>K:→ 419.700 98486091 AW/BS LD FPM 100x118x10</p> <p>K:→ 763.136 40100314 ASW LD FPM 90x115x13</p> <p>N:← 419.730 99433965 AW/BS RD FPM 55x70x8</p>	
<p>VAS 790.860 FPM 143.930 40101573 FPM 8x</p>	<p>AAS 898.310 481.300 (4x) +481.320 (4x)</p>  <p>481.320 7300877 4x</p> 	<p>481.300 98425767 4x</p> 	<p>b) 877.910 M 22x1,5x10</p> <p>b) 128.503 16508460 CU A 22x27x1,5</p>	<p>K:← 419.730 99433965 AW/BS RD FPM 55x70x8</p> <p>K:→ 419.700 98486091 AW/BS LD FPM 100x118x10</p> <p>N:← 419.730 99433965 AW/BS RD FPM 55x70x8</p>	
<p>VAS 790.860 FPM 143.930 40101573 FPM 8x</p>	<p>AAS 898.310 481.300 (4x) +481.320 (4x)</p>  <p>481.320 7300877 4x</p> 	<p>481.300 98425767 4x</p> 	<p>b) 877.910 M 22x1,5x10</p> <p>b) 128.503 16508460 CU A 22x27x1,5</p>	<p>K:← 419.730 99433965 AW/BS RD FPM 55x70x8</p> <p>K:→ 419.700 98486091 AW/BS LD FPM 100x118x10</p> <p>N:← 419.730 99433965 AW/BS RD FPM 55x70x8</p> <p>N:→ 302.589 9400236149 A WD FPM 35x50x8</p>	

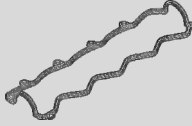



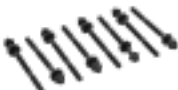



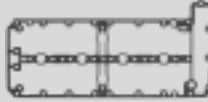







<p>FIAT</p> 				
<p>8140.43S</p> <p>4 Cyl. 2798 ccm Cyl. 94,4 Ø</p> <p>Ducato JTD 11/2000 →</p>	<p>S⊕* 181.270 71718011 +500363870</p>  <p>ES⊕ 181.320 71718012</p> 	<p>863.080 99432354</p>  <p> 0,400 mm → 0,500 mm</p> <p>1,20 mm $\frac{\pm}{\pm}$</p> <p>863.110 99432353</p>  <p> 0,510 mm → 0,600 mm</p> <p>1,30 mm $\frac{\pm}{\pm}$</p> <p>863.120 99460983</p>  <p> 0,610 mm → 0,700 mm</p> <p>1,40 mm $\frac{\pm}{\pm}$</p> <p>863.130 99458402</p>  <p> 0,710 mm → 0,800 mm</p> <p>1,50 mm $\frac{\pm}{\pm}$</p>	<p>ZKS 374.180 4854648 (14x) +99442951 (8x) M 12x1,25x90/163</p> 	<p>199.060 500388381</p> 
<p>8140.23.2200</p> <p>4 Cyl. 2800 ccm Cyl. 94,4 Ø</p> <p>Ducato TD 04/2005 →</p>	<p>S⊕* 863.150 71713696</p>  <p>ES⊕ 863.160</p>  <p>CS* 863.170</p>	<p>863.080 99432354</p>  <p> 0,400 mm → 0,500 mm</p> <p>1,20 mm $\frac{\pm}{\pm}$</p> <p>863.110 99432353</p>  <p> 0,510 mm → 0,600 mm</p> <p>1,30 mm $\frac{\pm}{\pm}$</p> <p>863.120 99460983</p>  <p> 0,610 mm → 0,700 mm</p> <p>1,40 mm $\frac{\pm}{\pm}$</p> <p>863.130 99458402</p>  <p> 0,710 mm → 0,800 mm</p> <p>1,50 mm $\frac{\pm}{\pm}$</p>	<p>ZKS 760.300 4854648 (10x) +4828150 (12x) M 12x1,25x119/163</p> 	<p>081.540 98472291</p> 

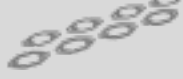





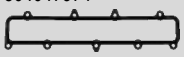



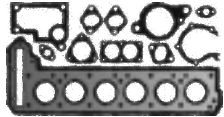
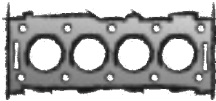

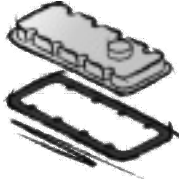









			<p>a) </p> <p>b) </p>	<p>K: </p> <p>N: </p>	
<p>VAS 790.860 FPM 143.930 40101573 FPM 8x</p>	<p>AAS 898.310 481.300 (4x) +481.320 (4x)</p>  <p>481.320 7300877 4x</p> 	<p>481.300 98425767 4x</p> 	<p>a) OWS 290.910 9943 2807 +9943 2808</p>  <p>a) 429.000 500327440</p>  <p>b) 877.910 M 22x1,5x10</p> <p>b) 878.040 incl. 128.503 M 22x1,5x10</p> <p>b) 128.503 16508460 CU A 22x27x1,5</p>	<p>K:← 199.220 98461673 IWD RD FPM 70x14</p> <p>K:→ 199.230 99468744 IWD LD FPM 114x13</p> <p>N:← 419.730 99433965 AW/BS RD FPM 55x70x8</p>	<p>TLS 714.810</p> 
<p>VAS 790.860 FPM 143.930 40101573 FPM 8x</p>	<p>AAS 898.310 481.300 (4x) +481.320 (4x)</p>  <p>481.320 7300877 4x</p> 	<p>481.300 98425767 4x</p> 	<p>a) OWS 290.910 9943 2807 +9943 2808</p>  <p>b) 877.910 M 22x1,5x10</p> <p>b) 878.040 incl. 128.503 M 22x1,5x10</p> <p>b) 128.503 16508460 CU A 22x27x1,5</p>	<p>K:← 199.220 98461673 IWD RD FPM 70x14</p> <p>K:→ 199.230 99468744 IWD LD FPM 114x13</p> <p>N:← 419.730 99433965 AW/BS RD FPM 55x70x8</p>	

<p>FIAT</p> 				
<p>8140.43</p> <p>4 Cyl. 2800 ccm Cyl. 94,4 Ø</p> <p>Ducato JTD 11/2003 → 07/2006</p> <p>Ducato TD 05/1998 → 07/2006</p> <p>Ducato TDI 10/1997 → 04/2002</p>	<p>S⊕* 181.260 71713696 +500363870</p>  <p>ES⊕ 198.900 71713695</p> 	<p>863.080 99432354</p>  <p> 0,400 mm → 0,500 mm</p> <p>1,20 mm $\frac{\pm}{\pm}$</p> <p>863.110 99432353</p>  <p> 0,510 mm → 0,600 mm</p> <p>1,30 mm $\frac{\pm}{\pm}$</p> <p>863.120 99460983</p>  <p> 0,610 mm → 0,700 mm</p> <p>1,40 mm $\frac{\pm}{\pm}$</p> <p>863.130 99458402</p>  <p> 0,710 mm → 0,800 mm</p> <p>1,50 mm $\frac{\pm}{\pm}$</p>	<p>ZKS 760.300 4854648 (10x) +4828150 (12x) M 12x1,25x119/163</p> 	<p>081.540 98472291</p> 
<p>8140.43N</p> <p>4 Cyl. 2800 ccm Cyl. 94,4 Ø</p> <p>Ducato JTD 04/2004 →</p>	<p>S⊕* 181.270 71718011 +500363870</p>  <p>ES⊕ 181.320 71718012</p> 	<p>863.080 99432354</p>  <p> 0,400 mm → 0,500 mm</p> <p>1,20 mm $\frac{\pm}{\pm}$</p> <p>863.110 99432353</p>  <p> 0,510 mm → 0,600 mm</p> <p>1,30 mm $\frac{\pm}{\pm}$</p> <p>863.120 99460983</p>  <p> 0,610 mm → 0,700 mm</p> <p>1,40 mm $\frac{\pm}{\pm}$</p> <p>863.130 99458402</p>  <p> 0,710 mm → 0,800 mm</p> <p>1,50 mm $\frac{\pm}{\pm}$</p>	<p>ZKS 374.180 4854648 (14x) +99442951 (8x) M 12x1,25x90/163</p> 	<p>199.060 500388381</p> 

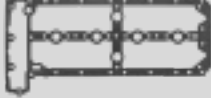
			<p>a) </p> <p>b) </p>	<p>K: </p> <p>N: </p>	
<p>VAS 790.860 FPM 143.930 40101573 FPM 8x</p>	<p>AAS 898.310 481.300 (4x) +481.320 (4x)</p>  <p>481.320 7300877 4x</p> 	<p>481.300 98425767 4x</p> 	<p>a) OWS 290.910 9943 2807 +9943 2808</p>  <p>a) 429.000 500327440</p>  <p>b) 877.910 M 22x1,5x10</p> <p>b) 878.040 incl. 128.503 M 22x1,5x10</p> <p>b) 128.503 16508460 CU A 22x27x1,5</p>	<p>K:← 199.220 98461673 IWD RD FPM 70x14</p> <p>K:→ 199.230 99468744 IWD LD FPM 114x13</p> <p>N:← 419.730 99433965 AW/BS RD FPM 55x70x8</p>	<p>TLS 714.810</p> 
<p>VAS 790.860 FPM 143.930 40101573 FPM 8x</p>	<p>AAS 898.310 481.300 (4x) +481.320 (4x)</p>  <p>481.320 7300877 4x</p> 	<p>481.300 98425767 4x</p> 	<p>a) OWS 290.910 9943 2807 +9943 2808</p>  <p>a) 429.000 500327440</p>  <p>b) 877.910 M 22x1,5x10</p> <p>b) 878.040 incl. 128.503 M 22x1,5x10</p> <p>b) 128.503 16508460 CU A 22x27x1,5</p>	<p>K:← 199.220 98461673 IWD RD FPM 70x14</p> <p>K:→ 199.230 99468744 IWD LD FPM 114x13</p> <p>N:← 419.730 99433965 AW/BS RD FPM 55x70x8</p>	<p>TLS 286.600</p> 

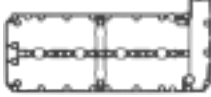
<p>FIAT</p> 				
<p>8140.63</p> <p>4 Cyl. 2800 ccm Cyl. 94,4 Ø</p> <p>Ducato 02/1998 → 04/2002</p> <p>Ducato TD 05/1998 → 11/2001</p>	<p>S⊕* 181.110 71713988 +500363870</p>  <p>ES⊕ 181.150 71713987</p> 	<p>181.010 500306170</p>  <p>0,750 mm → 0,850 mm</p> <p>1,60 mm $\frac{\pm}{\pm}$ 96 Ø</p> <p>181.060 500306171</p>  <p>0,850 mm → 0,950 mm</p> <p>1,70 mm $\frac{\pm}{\pm}$ 96 Ø 1 ⊗</p> <p>181.070 500306172</p>  <p>0,950 mm → 1,050 mm</p> <p>1,80 mm $\frac{\pm}{\pm}$ 96 Ø 2 ⊗</p>	<p>ZKS 374.180 4854648 (14x) +99442951 (8x) M 12x1,25x90/163</p> 	<p>199.060 500388381</p> 
<p>XFW</p> <p>6 Cyl. 2946 ccm Cyl. 87,0 Ø</p> <p>Ulysse 08/2002 → 06/2011</p>		<p>123.022 9651513480 0,74 mm $\frac{\pm}{\pm}$ L</p>  <p>123.601 9636179280 0,95 mm $\frac{\pm}{\pm}$ L</p>  <p>123.032 9651513280 0,74 mm $\frac{\pm}{\pm}$ R</p>  <p>123.611 9636180080 0,95 mm $\frac{\pm}{\pm}$ R</p> 	<p>ZKS 152.570 ● 9626469380 (8x) M 10x1,5x148 2x</p> 	
<p>F1CE0441A</p> <p>4 Cyl. 2999 ccm Cyl. 95,8 Ø</p> <p>Ducato 04/2009 →</p>		<p>589.110 504093500 1,10 mm $\frac{\pm}{\pm}$ 95,8 Ø</p>  <p>340.260 504093499 1,20 mm $\frac{\pm}{\pm}$ 95,8 Ø</p>  <p>590.080 504093501 1,30 mm $\frac{\pm}{\pm}$ 95,8 Ø</p> 	<p>ZKS 877.740</p>	<p>351.260 504161187 →Mot. 1101495</p>  <p>485.510 504175733 Mot. 1101496→</p> 

			<p>a) </p> <p>b) </p>	<p>K: </p> <p>N: </p>	
<p>VAS 790.860 FPM 143.930 40101573 FPM 8x</p>	<p>AAS 898.310 481.300 (4x) +481.320 (4x)</p>  <p>481.320 7300877 4x</p> 	<p>481.300 98425767 4x</p> 	<p>a) OVS 290.910 9943 2807 +9943 2808</p>  <p>a) 429.000 500327440</p>  <p>b) 877.910 M 22x1,5x10</p> <p>b) 878.040 incl. 128.503 M 22x1,5x10</p> <p>b) 128.503 16508460 CU A 22x27x1,5</p>	<p>K:← 199.220 98461673 IWD RD FPM 70x14</p> <p>K:→ 199.230 99468744 IWD LD FPM 114x13</p> <p>N:← 419.730 99433965 AW/BS RD FPM 55x70x8</p>	
<p>VAS 424.820 FPM 403.730 9400956389 FPM 24x</p>				<p>K:← 148.230 9624290880 AS RD FPM/ACM 42x56x6,5</p> <p>K:→ 509.930 9400119149 ASW LD FPM/ACM 98x120x7</p> <p>N:← 135.140 9609874280 ASW RD FPM 38x50x6 4x</p>	
<p>718.210 500395378 FPM 16x</p> 	<p>452.400 504022754</p> 	<p>351.270 504047974</p> 	<p>a) 548.200 504083813</p>  <p>b) 128.503 16508460 CU A 22x27x1,5</p>	<p>K:← 353.780 504056152 AW RD PTFE/ACM 50x70x11</p> <p>K:→ 353.090 504180969 SP LD FPM 90x120x13,65</p>	

FIAT 				
F1CE3481E 4 Cyl. 2999 ccm Cyl. 95,8 Ø Ducato Multijet 06/2011 →	ES⊕ 452.680	589.110 504093500 1,10 mm $\frac{\pm}{\pm}$ 95,8 Ø  340.260 504093499 1,20 mm $\frac{\pm}{\pm}$ 95,8 Ø  590.080 504093501 1,30 mm $\frac{\pm}{\pm}$ 95,8 Ø 	ZKS 877.740	351.260 504161187  452.640 504239811 4x 390.600 5801438487 4x
F1CE0481D F1CE3481M 4 Cyl. 2999 ccm Cyl. 95,8 Ø Ducato Multijet 07/2006 →	S⊕* 586.540 8094874  ES⊕ 586.530 8094873 	589.110 504093500 1,10 mm $\frac{\pm}{\pm}$ 95,8 Ø  340.260 504093499 1,20 mm $\frac{\pm}{\pm}$ 95,8 Ø  590.080 504093501 1,30 mm $\frac{\pm}{\pm}$ 95,8 Ø 	ZKS 877.740	351.260 504161187  452.640 504239811 4x 390.600 5801438487 4x
F1CE3481N 4 Cyl. 2999 ccm Cyl. 95,8 Ø Ducato Multijet 04/2010 →	S⊕* 452.660 ES⊕ 452.680	589.110 504093500 1,10 mm $\frac{\pm}{\pm}$ 95,8 Ø  340.260 504093499 1,20 mm $\frac{\pm}{\pm}$ 95,8 Ø  590.080 504093501 1,30 mm $\frac{\pm}{\pm}$ 95,8 Ø 	ZKS 877.740	351.260 504161187  452.640 504239811 4x 390.600 5801438487 4x
F1CFA401A/C 4 Cyl. 2999 ccm Cyl. 95,8 Ø Ducato 04/2009 →	S⊕* 654.780 ES⊕ 654.770 500086113 CS* 655.750	340.260 504093499 1,20 mm $\frac{\pm}{\pm}$ 95,8 Ø 	ZKS 877.740	485.510 504175733 
ERB 6 Cyl. 3604 ccm Cyl. 96,0 Ø Freemont 08/2011 →	ES⊕ 694.360 CS 854.010 →08/2012 OKS 512.820 OKS 854.020 →08/2012 	586.270 K05184455AE L  586.280 K05184456AE R 	ZKS 949.390 M 12x1,5x128 2x	527.780 K05184596AE L  527.800 K05184595AE R 523.950 ↑ 2x

			<p>a) </p> <p>b) </p>	<p>K: </p> <p>N: </p>	
<p>718.210 500395378 FPM 16x</p> 	<p>452.400 504022754</p> 	<p>351.270 504047974</p> 	<p>a) 548.200 504083813</p>  <p>b) 128.503 16508460 CU A 22x27x1,5</p>	<p>K:← 353.780 504056152 AW RD PTFE/ACM 50x70x11</p> <p>K:→ 353.090 504180969 SP LD FPM 90x120x13,65</p>	
<p>718.210 500395378 FPM 16x</p> 	<p>452.400 504022754</p> 	<p>351.270 504047974</p> 	<p>a) 548.200 504083813</p>  <p>b) 128.503 16508460 CU A 22x27x1,5</p>	<p>K:← 353.780 504056152 AW RD PTFE/ACM 50x70x11</p> <p>K:→ 353.090 504180969 SP LD FPM 90x120x13,65</p>	
<p>718.210 500395378 FPM 16x</p> 	<p>452.400 504022754</p> 	<p>351.270 504047974</p> 	<p>a) 548.200 504083813</p>  <p>b) 128.503 16508460 CU A 22x27x1,5</p>	<p>K:← 353.780 504056152 AW RD PTFE/ACM 50x70x11</p> <p>K:→ 353.090 504180969 SP LD FPM 90x120x13,65</p>	
<p>718.210 500395378 FPM 16x</p> 	<p>452.400 504022754</p> 	<p>351.270 504047974</p> 	<p>a) 548.200 504083813</p>  <p>b) 128.503 16508460 CU A 22x27x1,5</p>	<p>K:← 353.780 504056152 AW RD PTFE/ACM 50x70x11</p> <p>K:→ 353.090 504180969 SP LD FPM 90x120x13,65</p>	
<p>VAS 424.820 FPM 403.730 9400956389 FPM 24x</p> 	<p>692.760 K68093232AA 2x</p> 	<p>524.330 K05148331AC 6x↓</p>	<p>a) 036.164 Dirko HT / EU</p> <p>a) 510.031 Dirko HT / USA/CDN/MEX</p> <p>a) 527.291 Dirko HT / RU</p> <p>a) 648.661 Dirko HT / BR</p> <p>b) 298.480 M 14x1,5x18</p>	<p>K:← 424.841 K68079589AA ASW RD PTFE/ACM 45x67x8</p> <p>K:← 520.690 ● K68079589AA ASW RD FPM 45x67x8,2</p>	

FORD



B-Max	3	998	88	08/2012		M1JA	994
B-Max	3	998	74	10/2012		SFJA SFJB SFJC SFJD	994
B-Max	3	998	92	10/2012		M1JE M1JH	994
B-Max	3	998	103	02/2016		YYJC	994
B-Max	4	1388	66	10/2012		RTJC SPJD SPJE	1012
B-Max	4	1388	64	08/2013		RTJC	1012
B-Max	4	1596	77	10/2012		IQJC	1034
B-Max TDCi	4	1499	55	10/2012		UGJC UGJG XUJA XUJB	1020
B-Max TDCi	4	1499	70	04/2015		XVJA XVJC	1020
B-Max TDCi	4	1560	70	10/2012		T3JB	1026
Capri	4	1593	53	08/1972	12/1977	LCE OHC TL 16 H	1028
Capri	4	1593	65	08/1972	12/1977	LE LEC	1028
Capri	4	1593	50	09/1974	12/1977	LAC	1028
Capri	4	1993	72	04/1974	12/1977	OHC TL 20 H	1098
Capri	4	1993	74	01/1978	12/1985	NEN OHC TL 20 H	1098
Capri	4	1994	64	01/1978	12/1985	TL20LNM	1098
Capri	6	2792	118	01/1981	04/1987	PRN	1148
C-Max	3	998	74	10/2012	06/2019	M2DA M2DC SFDA	994
C-Max	3	998	92	10/2012	06/2019	M1DA M1DD	994
C-Max	3	999	74	07/2018	06/2019	B3DA	996
C-Max	4	1498	110	03/2015	06/2019	M8DB M8DF	1016
C-Max	4	1498	134	03/2015	06/2019	M9DB	1016
C-Max	4	1596	74	02/2007	09/2010	HWDA HWDB SHDA SHDB SHDC	1032
C-Max	4	1596	85	04/2007	09/2010	HXDA HXDB SIDA	1028
C-Max	4	1596	77	10/2010	06/2019	IQDA IQDB	1034

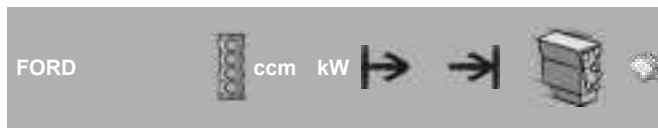

C-Max	4	1596	63	12/2010	06/2019	XTDA	1034
C-Max	4	1596	92	12/2010	06/2019	PNDA PNDD	1034
C-Max	4	1596	110	12/2010	06/2019	JQDA JQDB	1032
C-Max	4	1596	134	12/2010	06/2019	JTDA JTDB	1032
C-Max	4	1596	88	02/2011	06/2019	MUDA MUDD	1034
C-Max	4	1596	86	02/2012	06/2019	MUDA MUDD	1034
C-Max	4	1798	90	02/2007	09/2010	QQDC	1082
C-Max	4	1798	92	02/2007	09/2010	Q7DA QQDA QQDB	1082
C-Max	4	1999	107	02/2007	09/2010	AODA AODB AODE SYDA	1112
C-Max	4	1999	103	01/2015	06/2019	UADA	1118
C-Max	4	1999	136	01/2015	06/2019	UADA	1118
C-Max TDCi	4	1499	70	03/2015	06/2019	XXDA XXDC XXDD	1020
C-Max TDCi	4	1499	77	03/2015	06/2019	AEDA	1020
C-Max TDCi	4	1499	88	03/2015	06/2019	XWDA XWDB XWDC XWDD XWDE	1020
C-Max TDCi	4	1560	66	02/2007	09/2010	GPDA HHDA HHDB	1024
C-Max TDCi	4	1560	74	02/2007	09/2010	G8DC MTDA	1024
C-Max TDCi	4	1560	80	02/2007	09/2010	G8DA G8DB G8DD	1024
C-Max TDCi	4	1560	70	12/2010	06/2019	T3DA T3DB	1026
C-Max TDCi	4	1560	85	12/2010	06/2019	T1DA T1DB	1026
C-Max TDCi	4	1753	85	02/2007	09/2010	KKDA KKDB	1052
C-Max TDCi	4	1997	98	02/2007	09/2010	G6DC G6DE G6DF	1102
C-Max TDCi	4	1997	100	02/2007	06/2019	G6DA G6DB G6DD G6DG UKDB	1102



FORD	ccm	kW	→	→		
C-Max TDCi	4	1997	103	04/2010	06/2019	UFDB 1104
C-Max TDCi	4	1997	120	12/2010	06/2019	TXDB 1104
C-Max TDCi	4	1997	85	02/2011	06/2019	TYDA 1104
C-Max TDCi	4	1997	110	03/2015	06/2019	T7DB 1104 T7DC T7DD
C-Max TDCi	4	1997	125	03/2015	06/2019	T8DE 1104
Consul	4	1993	73	01/1972	12/1975	NE 1096
Cortina	4	1593	63	10/1970	03/1972	LCJ 1028
Cougar	4	1988	96	08/1998	12/2001	EDBA 1092 EDBB EDBC EDBD
Cougar	6	2495	151	01/2000	12/2001	SGA 1136
Cougar	6	2495	125	06/2000	12/2001	LCBB 1136 LCBC LCBE
Cougar	6	2544	125	08/1998	12/2001	LCBA 1136 LCBB 1144 LCBC LCBE
Courier	4	1299	44	07/1997	08/1999	JKKC 1006
Courier	4	1388	66	07/1997	08/1999	FVKB 1008
Courier	4	1596	74	08/2001	12/2011	FYDC 1030
Courier	4	1753	44	06/1999	02/2002	RTK 1074
Courier	4	1796	85	03/1998	02/2002	RKA 1080
Courier	4	2499	80	03/1998	09/2005	WL-T 1142
Ecosport	3	998	92	10/2013		M1JC 994 M1JJ M1JU
Ecosport	3	998	103	03/2016		YYJD 994 YYJF
Ecosport	3	998	74	04/2018		SFJL 994
Ecosport	4	1498	82	10/2013		UEJB 1018
Ecosport	4	1596	90	08/2012		HXJD 1034 IQJB
Ecosport	4	1999	125	01/2018		MGDA 1118
Ecosport TDCi	4	1499	67	10/2012		UGJE 1020
Ecosport TDCi	4	1499	66	10/2013		UGJE 1020
Ecosport TDCi	4	1499	70	05/2015		XVJD 1020
Ecosport TDCi	4	1499	74	05/2015		UGJM 1020 XUJH 1022 ZZJA
Ecosport TDCi	4	1499	92	11/2017		ZTJA 1022 ZTJB ZTJC

FORD	ccm	kW	→	→		
Escort	4	1117	40	09/1980	08/1983	GLB 998
Escort	4	1117	37	03/1981	09/1990	GLB 998 GSE GSG
Escort	4	1296	51	09/1980	07/1988	JPA 1004
Escort	4	1297	44	01/1986	07/1990	JBB 1006 JLA JLB
Escort	4	1297	46	07/1988	10/1990	JBA 1006
Escort	4	1299	44	07/1990	02/1999	J4B 1008 J6A
Escort	4	1299	46	07/1990	12/1994	JBD 1006
Escort	4	1391	52	07/1990	12/1994	F6F 1014 F6G
Escort	4	1391	55	09/1990	02/1999	F4B 1012 FUH 1014
Escort	4	1391	54	01/1995	08/2000	F4B 1012
Escort	4	1392	51	10/1985	10/1990	FUAA 1014
Escort	4	1392	54	01/1986	12/1999	F4B 1012 F6B 1014 F6D FUC
Escort	4	1392	55	01/1986	07/1990	FUA 1014
Escort	4	1392	52	07/1990	01/1995	F6F 1014 F6G
Escort	4	1593	62	08/1969	11/1974	TL 16M 1028
Escort	4	1597	58	09/1980	07/1990	LP1 1042 LP2 LPA
Escort	4	1597	71	09/1980	10/1982	LUA 1042
Escort	4	1597	85	05/1982	12/1985	LUAE 1042
Escort	4	1597	77	10/1982	07/1990	LR1 1040 LR2 1042 LRA LRB
Escort	4	1597	66	07/1985	07/2000	L1E 1038 L1K 1040 L4B 1042 LUC
Escort	4	1597	60	02/1986	07/1990	LUC 1042
Escort	4	1597	75	08/1989	07/1990	LJB 1040
Escort	4	1597	65	01/1994	12/1996	L1H 1038
Escort	4	1597	70	01/2001	08/2002	L1K 1038
Escort	4	1598	66	01/1986	08/1992	L4B 1040 LUC 1042 LUJ 1044 LUK
Escort	4	1598	65	04/1989	07/1990	LUG 1042

FORD



FORD ccm kW

Escort	4	1598	77	07/1990	08/1993	LJF	1040
Escort	4	1608	40	02/1984	07/1990	LTA LTC	1044
Escort	4	1753	44	07/1988	08/2000	RTA RTB RTE RTF RTH	1068 1070
Escort	4	1753	51	12/1995	06/2001	RVA	1064
Escort	4	1796	77	02/1992	08/1998	RDA	1078
Escort	4	1796	96	02/1992	08/2000	RQB	1078
Escort	4	1796	85	01/1995	02/1999	RKC	1078
Escort	4	1993	73	03/1973	02/1977	NE	1096
Escort	4	1993	80	08/1975	08/1980	NE	1096
Escort TD	4	1753	55	05/1991	12/1992	D18TRFL	1060
Escort TD	4	1753	66	02/1993	08/2000	RFD RFK RFN RFS	1056 1064 1066
Everest	5	3198	147	01/2016	02/2020	P5-AT	1150
Fiesta	4	957	29	05/1976	11/1986	TKA TKW	994
Fiesta	4	957	33	05/1976	11/1989	TKB TLA	994
Fiesta	3	998	92	09/2012		M1JE M1JH M1JL M1JM M1JP	994
Fiesta	3	998	59	10/2012		P4JA P4JB P4JC P4JD	996
Fiesta	3	998	48	01/2013		XMJA XMJB XMJC XMJD	996
Fiesta	3	998	74	01/2013		SFJA SFJB SFJC SFJD SFJE SFJF SFJH SFJJ SFJK SFJN SFJP	994
Fiesta	3	998	103	05/2014		YYJA YYJB YYJE YYJG	994

FORD ccm kW

Fiesta	3	998	63	04/2018		Q0JA Q0JB Q0JC Q0JD	994
Fiesta	4	999	33	04/1989	12/1991	TLB	996
Fiesta	4	999	38	04/1996	09/1999	ZH10JRB	998
Fiesta	4	999	48	09/1999	08/2004	C4E	998
Fiesta	4	999	49	05/2002	03/2008	C4E	998
Fiesta	4	999	70	05/2002	12/2006	CPJA	998
Fiesta	4	999	54	09/2006		ZH10JRY	998
Fiesta	3	999	92	09/2013		M1JE M1JH	994
Fiesta	4	1001	33	03/1989	12/1995	TLB	996
Fiesta	3	1084	52	05/2017		XPJA XPJB XPJC XPJD	998
Fiesta	3	1084	63	05/2017		XYJA XYJB XYJC XYJD XYJE XYJF	998
Fiesta	3	1084	55	04/2019		FSJB	998
Fiesta	4	1117	39	05/1976	11/1986	GL1 GLA	998
Fiesta	4	1117	40	02/1981	08/1983	GLW	998
Fiesta	4	1117	37	09/1983	02/1989	GLC GSF	998
Fiesta	4	1117	36	05/1986	02/1989	GSH	998
Fiesta	4	1119	37	03/1989	12/1995	G6A	1000
Fiesta	4	1119	40	03/1989	12/1995	GUD GUE	1000
Fiesta	4	1242	55	08/1995	06/2008	DHA DHB DHC DHD DHE DHF DHG FUJA FUJB	1000 1002
Fiesta	4	1242	51	03/2003	06/2008	M7JA M7JB	1002
Fiesta	4	1242	44	06/2008	04/2017	STJA STJB STJC	1002
Fiesta	4	1242	60	06/2008		SNJA SNJB SNJC SNJD	1002



FORD	4	ccm	kW	→	→		
Fiesta	4	1296	51	09/1983	01/1987	JPC	1004
Fiesta	4	1297	51	09/1983	09/1989	JPC	1004
Fiesta	4	1297	44	03/1989	12/1995	JBB	1006 JBC 1008
Fiesta	4	1299	44	03/1989	08/2008	BAJA	1004 J4C 1006 J4J 1008 J4L J4Q J4R J4T J6B JBC
Fiesta	4	1299	37	08/1995	01/2002	JJA	1006 JJC JJE JJJ JKK JMM
Fiesta	4	1299	51	11/2001	06/2008	A9JA	1004 A9JB
Fiesta	4	1299	55	01/2002	12/2004	A9JA	1004
Fiesta	4	1388	66	04/1996	04/2002	FHA	1008 FHE
Fiesta	4	1388	59	11/2001	06/2008	FXJA	1010 FXJB
Fiesta	4	1388	71	10/2008	04/2017	RTJA	1010 RTJB 1012 RTJD SPJA SPJC SPJE
Fiesta	4	1388	68	01/2009	04/2017	RTJA	1010 RTJB 1012 RTJD
Fiesta	4	1391	52	03/1989	12/1995	F6E	1014
Fiesta	4	1391	54	03/1989	12/1995	F4A	1012 FUG 1014 FUJ
Fiesta	4	1392	51	09/1983	01/1987	FUBA	1014
Fiesta	4	1392	55	10/1985	12/1996	FUB	1014 FUF
Fiesta	4	1392	52	09/1986	09/1989	F6A	1014 F6C
Fiesta	4	1392	54	02/1987	02/1989	FUD	1014
Fiesta	4	1499	82	04/2012		C154CSG	1018

FORD	4	ccm	kW	→	→		
Fiesta	4	1499	63	05/2017		XUJC	1020 XUJD XUJE XUJF XUJG XUJK XUJL XUJM XUJN XVJE
Fiesta	4	1499	88	05/2017		XWJA	1020 XWJB XWJC
Fiesta	4	1596	72	02/1999	09/2002	L1V	1034
Fiesta	4	1596	76	02/2000	01/2002	L1T	1034 L1V
Fiesta	4	1596	74	11/2001	06/2008	FYJA	1030 FYJB
Fiesta	4	1596	88	06/2008		HXJA	1034 HXJB HXJE
Fiesta	4	1596	85	06/2010		C16HDEX	1028
Fiesta	4	1596	89	10/2010		HXJA	1034 HXJB
Fiesta	4	1596	99	12/2010		U5JA	1034
Fiesta	4	1596	77	09/2012		IQJC	1034 IQJE
Fiesta	4	1596	96	03/2013	03/2015	C16HDEX	1028
Fiesta	4	1596	134	03/2013		JTJA	1032 JTJB
Fiesta	4	1596	94	05/2013		C16HDEX	1028
Fiesta	4	1596	147	06/2016	04/2017	JTJC	1032
Fiesta	4	1597	70	03/1984	06/2002	L1V	1034 LUD 1042
Fiesta	4	1597	71	04/1984	02/1989	LUB	1042
Fiesta	4	1597	58	01/1985	11/1989	LP3	1042
Fiesta	4	1597	65	01/1989	12/1995	L1G	1038 LUH 1044
Fiesta	4	1597	66	03/1989	12/1992	LUH	1044
Fiesta	4	1597	81	03/1989	01/1994	LJC	1040
Fiesta	4	1598	76	03/1989	03/1993	LJD	1040
Fiesta	4	1608	40	09/1983	09/1989	LTB	1044
Fiesta	4	1753	43	03/1989	12/1995	RTC	1070 RTD RTG
Fiesta	4	1753	44	03/1989	04/2002	RTC	1070 RTD 1074 RTG RTJ RTK

FORD



FORD	ccm	kW	→	→		
Fiesta	4	1753	55	07/1993	08/1995	D18TRFL 1060
Fiesta	4	1796	77	02/1992	12/1995	RDB 1078
Fiesta	4	1796	96	02/1992	12/1995	RQC 1078
Fiesta	4	1999	110	03/2005	06/2008	N4JB 1112
Fiesta DI	4	1753	55	04/2000	08/2003	RTN 1076 RTP RTQ
Fiesta TD	4	1753	55	03/1993	08/2003	RFL 1060 RTN 1076 RTP RTQ
Fiesta TDCi	4	1399	50	11/2001		F6JA 1014 F6JB 1016 F6JC F6JD KVJA
Fiesta TDCi	4	1399	51	07/2010		F6JD 1014 KVJA 1016
Fiesta TDCi	4	1499	55	09/2012		UGJC 1020 XUJA XUJB
Fiesta TDCi	4	1499	70	05/2015		XVJB 1020 XVJC
Fiesta TDCi	4	1499	88	09/2018		XWJA 1020 XWJB XWJC
Fiesta TDCi	4	1499	63	04/2019		XUJC 1020 XUJD XUJE XUJF XUJG XUJK XUJL XUJM XUJN
Fiesta TDCi	4	1560	66	11/2004		HHJA 1024 HHJB HHJC HHJD HHJE
Fiesta TDCi	4	1560	55	06/2008	12/2012	HHJF 1024 UBJA
Fiesta TDCi	4	1560	70	02/2010		T3JA 1026 TZJA TZJB
Fiesta TDCi	4	1499	67	01/2011	12/2016	15DSOX 1020
Fiesta TDCi	4	1499	88	05/2017		XWJA 1020 XWJB XWJC

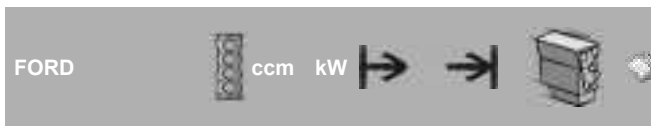

FORD	ccm	kW	→	→		
Fiesta TDCI	4	1499	63	04/2018		XUJC 1020 XUJD XUJE XUJF XUJG XUJK XUJL XUJM XUJN
Focus	3	998	74	02/2012		M2DA 994 M2DB M2DC SFDA SFDB
Focus	3	998	92	02/2012		M1DA 994 M1DC M1DD
Focus	3	998	103	10/2017		M1DH 994
Focus	3	998	63	05/2018		SFDC 994
Focus	3	999	74	01/2018		B3DA 996
Focus	4	1388	55	10/1998	03/2005	FXDA 1010 FXDB FXDC FXDD
Focus	4	1388	59	07/2004	09/2012	ASDA 1008 ASDB
Focus	4	1498	110	09/2014		M8DA 1016 M8DB M8DD M8DE
Focus	4	1498	134	09/2014		M9DA 1016 M9DB
Focus	4	1499	132	05/2015		M9DA 1016 M9DB
Focus	4	1499	70	01/2018		Z2DA 1022
Focus	4	1499	88	01/2018		ZTDA 1022 ZTDB
Focus	4	1596	74	10/1998	09/2012	FYDA 1030 FYDB 1032 FYDC FYDD FYDH HWDA HWDB SHDA SHDB SHDC
Focus	4	1596	75	01/2002	11/2004	FYDH 1030
Focus	4	1596	85	07/2004	09/2013	C16HDEX 1028 HXDA HXDB SIDA
Focus	4	1596	81	01/2010		C16HDEZ 1028
Focus	4	1596	77	07/2010		IQDA 1034 IQDB



FORD	ccm	kW	→	→		
Focus	4	1596	88	07/2010		MUDA 1034 MUDD
Focus	4	1596	92	07/2010		PNDA 1034 PNDD
Focus	4	1596	110	07/2010		JQDA 1032 JQDB YUDA
Focus	4	1596	134	07/2010		JTDA 1032 JTDB
Focus	4	1596	63	08/2011		XTDA 1034
Focus	4	1596	86	02/2012		MUDA 1034
Focus	4	1598	76	07/2003	06/2007	FYDA 1030
Focus	4	1796	85	10/1998	03/2005	EYDB 1078 EYDC EYDD EYDE EYDF EYDG EYDI EYDJ EYDL
Focus	4	1796	82	02/2003	01/2005	EYDL 1078
Focus	4	1798	96	12/2005	01/2008	QQDD 1082
Focus	4	1798	92	01/2006	09/2012	Q7DA 1082 QQDA QQDB
Focus	4	1988	96	10/1998	11/2004	EDDB 1092 EDDC EDDD EDDF
Focus	4	1988	85	02/1999	11/2004	EDDD 1092
Focus	4	1988	92	07/2000	05/2005	EDDB 1092
Focus	4	1988	93	07/2000	05/2005	EDDB 1092 EDDC EDDD EDDF
Focus	4	1988	158	10/2002	11/2004	HMDA 1092
Focus	4	1995	110	01/2018		YLDA 1098
Focus	4	1995	140	04/2019		BCDA 1098
Focus	4	1996	140	04/2019		BCDA 1098
Focus	4	1999	107	07/2004	09/2012	AODA 1112 AODB AODE SYDA
Focus	4	1999	104	06/2005	09/2012	AODE 1112 SYDA
Focus	4	1999	109	04/2010	09/2013	SYDA 1112
Focus	4	1999	125	07/2010		MGDA 1118
Focus	4	1999	119	04/2011		C20HDEX 1110

FORD	ccm	kW	→	→		
Focus	4	1999	184	07/2012		R9DA 1112 R9DB R9DC R9DD
Focus	4	1999	110	10/2013		XQDA 1118
Focus	4	1999	131	10/2013	06/2019	C20HDEX 1110
Focus	5	2521	224	01/2009	07/2011	JZDA 1144
Focus	5	2521	257	05/2010	07/2011	JZDA 1144
Focus	5	2522	166	10/2005	09/2012	HYDA 1144
Focus C-Max	4	1596	74	10/2003	03/2007	HWDA 1032 HWDB SHDA SHDB SHDC
Focus C-Max	4	1596	85	08/2004	03/2007	HXDA 1028 SIDA
Focus C-Max	4	1798	88	10/2003	03/2007	CSDA 1082 CSDB
Focus C-Max	4	1798	92	04/2004	03/2007	Q7DA 1082 QQDA QQDB
Focus C-Max	4	1798	90	09/2005	03/2007	QQDC 1082
Focus C-Max	4	1999	107	03/2004	03/2007	AODA 1112 AODB AODE SYDA
Focus C-Max TDCi	4	1560	80	10/2003	03/2007	G8DA 1024 G8DB G8DD G8DE G8DF
Focus C-Max TDCi	4	1560	66	02/2005	03/2007	HHDA 1024 HHDB
Focus C-Max TDCi	4	1753	85	01/2005	03/2007	KKDA 1052 KKDB
Focus C-Max TDCi	4	1997	98	10/2003	03/2007	G6DC 1102 G6DE G6DF
Focus C-Max TDCi	4	1997	100	10/2003	03/2007	G6DA 1102 G6DB G6DD G6DG
Focus DI/TDDi	4	1753	66	10/1998	11/2004	C9DA 1048 C9DB C9DC
Focus DI/TDDi	4	1753	55	08/1999	03/2005	BHDA 1046 BHDB
Focus TDCi	4	1499	70	09/2014		XXDA 1020 XXDC XXDD
Focus TDCi	4	1499	77	09/2014		AEDA 1020 XXDB

FORD

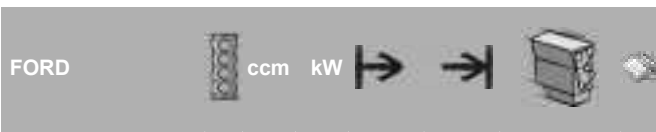

Focus TDCi	4	1499	88	09/2014		XWDA 1020 XWDB XWDC XWDD XWDE
-------------------	---	------	----	---------	--	---

Focus TDCi	4	1560	66	07/2004	09/2012	GPDA 1024 GPDB GPDC HHDA HHDB
-------------------	---	------	----	---------	---------	---

Focus TDCi	4	1560	74	07/2004	09/2012	G8DC 1024 MTDA
-------------------	---	------	----	---------	---------	-------------------

Focus TDCi	4	1560	80	07/2004	09/2012	G8DA 1024 G8DB G8DD G8DE G8DF
-------------------	---	------	----	---------	---------	---

Focus TDCi	4	1560	81	12/2007	09/2012	G8DA 1024
-------------------	---	------	----	---------	---------	-----------

Focus TDCi	4	1560	70	07/2010		T3DA 1026 T3DB
-------------------	---	------	----	---------	--	-------------------

Focus TDCi	4	1560	85	07/2010		T1DA 1026 T1DB
-------------------	---	------	----	---------	--	-------------------

Focus TDCi	4	1560	77	05/2012		NGDA 1026 NGDB
-------------------	---	------	----	---------	--	-------------------

Focus TDCi	4	1753	85	03/2001	09/2012	F9DA 1050 F9DB 1052 KKDA
-------------------	---	------	----	---------	---------	--------------------------------

Focus TDCi	4	1753	74	08/2002	03/2005	FFDA 1048
-------------------	---	------	----	---------	---------	-----------

Focus TDCi	4	1997	98	07/2004	01/2008	G6DE 1102 G6DF
-------------------	---	------	----	---------	---------	-------------------

Focus TDCi	4	1997	100	07/2004		G6DA 1102 G6DB 1104 G6DD G6DG UKDB
-------------------	---	------	-----	---------	--	--

Focus TDCi	4	1997	85	07/2010		TYDA 1104
-------------------	---	------	----	---------	--	-----------

Focus TDCi	4	1997	103	07/2010		UFDB 1104
-------------------	---	------	-----	---------	--	-----------

Focus TDCi	4	1997	120	07/2010		TXDB 1104
-------------------	---	------	-----	---------	--	-----------

Focus TDCi	4	1997	110	11/2014		T7DA 1104 T7DB
-------------------	---	------	-----	---------	--	-------------------

Focus TDCi	4	1997	136	11/2014		T8DA 1104
-------------------	---	------	-----	---------	--	-----------

Focus TDDi	4	1753	66	08/1998	03/2005	C9DA 1048 C9DB C9DC
-------------------	---	------	----	---------	---------	---------------------------

Focus TDDi	4	1753	55	08/1999	03/2005	BHDA 1046 BHDB
-------------------	---	------	----	---------	---------	-------------------

Fusion	4	1242	55	08/2004	12/2012	FUJA 1002 FUJB
---------------	---	------	----	---------	---------	-------------------

Fusion	4	1299	44	11/2002	07/2005	BAJA 1004
---------------	---	------	----	---------	---------	-----------



Fusion	4	1388	59	08/2002	12/2012	FXJA 1010 FXJB 1012 FXJC UTJA
---------------	---	------	----	---------	---------	--

Fusion	4	1596	74	08/2002	11/2009	FYJA 1030 FYJB FYJC
---------------	---	------	----	---------	---------	---------------------------

Fusion TDCi	4	1399	50	08/2002	12/2012	F6JA 1014 F6JB
--------------------	---	------	----	---------	---------	-------------------

Fusion TDCi	4	1560	66	11/2004	12/2012	HHJA 1024 HHJB
--------------------	---	------	----	---------	---------	-------------------

Galaxy	4	1499	118	01/2015	06/2018	UNCI 1016 UNCK UNCK
---------------	---	------	-----	---------	---------	---------------------------

Galaxy	4	1499	121	07/2018		C15HDTX 1016
---------------	---	------	-----	---------	--	--------------

Galaxy	4	1596	118	11/2010	06/2015	JTWA 1032 JTWB
---------------	---	------	-----	---------	---------	-------------------

Galaxy	4	1995	88	07/2018		YNCA 1098
---------------	---	------	----	---------	--	-----------

Galaxy	4	1995	110	07/2018		YMCB 1098
---------------	---	------	-----	---------	--	-----------

Galaxy	4	1995	140	07/2018		BCCC 1098
---------------	---	------	-----	---------	--	-----------

Galaxy	4	1995	176	07/2018		YLCB 1098
---------------	---	------	-----	---------	--	-----------

Galaxy	4	1998	85	11/1995	05/2006	NSE 1110 ZVSA
---------------	---	------	----	---------	---------	------------------

Galaxy	4	1999	107	05/2006	06/2015	AOWA 1112 AOWB TBWA TBWB
---------------	---	------	-----	---------	---------	-----------------------------------

Galaxy	4	1999	149	03/2010	06/2015	TNWA 1116
---------------	---	------	-----	---------	---------	-----------

Galaxy	4	1999	146	07/2010	06/2015	TNWB 1116
---------------	---	------	-----	---------	---------	-----------

Galaxy	4	1999	176	01/2015		R9CD 1112 R9CI
---------------	---	------	-----	---------	--	-------------------

Galaxy	4	2261	118	09/2007	06/2015	SEWA 1128
---------------	---	------	-----	---------	---------	-----------

Galaxy	4	2295	107	09/1996	05/2006	E5SA 1130 Y5B
---------------	---	------	-----	---------	---------	------------------

Galaxy	4	2295	103	09/2001	05/2006	E5SB 1130
---------------	---	------	-----	---------	---------	-----------

Galaxy	6	2792	128	11/1995	07/2000	AAA 1146 AMY
---------------	---	------	-----	---------	---------	-----------------

Galaxy	6	2792	150	04/2000	05/2006	AYL 1146
---------------	---	------	-----	---------	---------	----------

Galaxy TDCi	4	1560	85	02/2011	06/2015	T1WA 1026 T1WB
--------------------	---	------	----	---------	---------	-------------------

Galaxy TDCi	4	1753	74	05/2006	06/2015	FFWA 1052
--------------------	---	------	----	---------	---------	-----------

Galaxy TDCi	4	1753	92	05/2006	06/2015	QYWA 1052
--------------------	---	------	----	---------	---------	-----------

Galaxy TDCi	4	1997	96	05/2006	06/2015	AZWA 1102
--------------------	---	------	----	---------	---------	-----------

Galaxy TDCi	4	1997	100	05/2006	06/2015	AZWC 1102 UKWA 1104
--------------------	---	------	-----	---------	---------	------------------------

FORD



FORD	ccm	kW	→	→		
Galaxy TDCi	4	1997	103	05/2006	06/2015	QXWA 1102 QXWB 1104 QXWC UFWA
Galaxy TDCi	4	1997	85	01/2007	06/2015	TYWA 1104
Galaxy TDCi	4	1997	120	03/2010	06/2015	TXWA 1104
Galaxy TDCi	4	1997	88	01/2015	06/2018	UFCA 1104 UFCB
Galaxy TDCi	4	1997	110	01/2015	06/2018	T7CI 1104 T7CJ T7CK T7CL
Galaxy TDCi	4	1997	132	01/2015	06/2018	T8CG 1104 T8CH T8CI T8CJ
Galaxy TDCi	4	1997	154	01/2015	06/2018	T9CB 1104 T9CC T9CD
Galaxy TDCi	4	2179	129	03/2008	12/2012	Q4WA 1120
Galaxy TDCi	4	2179	147	11/2010	06/2015	KNWA 1120
Galaxy TDI	4	1896	66	03/1995	05/2006	1Z 1084 AHU 1086 ANU
Galaxy TDI	4	1896	81	08/1997	04/2000	AFN 1084 AVG 1090
Galaxy TDI	4	1896	85	04/2000	05/2006	AUY 1088
Galaxy TDI	4	1896	96	02/2003	05/2006	ASZ 1088
Galaxy TDI	4	1896	110	05/2005	05/2006	BTB 1090
Granada	4	1993	74	08/1979	08/1985	NEP 1098
Granada	4	1993	77	08/1981	08/1985	NEK 1098
Granada	4	1994	73	01/1975	12/1975	TL 20 LC 1096
Granada	4	1994	64	01/1976	07/1979	OHC LC 1096 TL 20 LC
Granada	4	1994	70	01/1976	07/1977	TL 20 LC 1096
Granada	4	2499	51	08/1982	08/1985	STP 1140
Granada	6	2792	99	08/1977	08/1985	PYA 1148
Granada	6	2792	108	08/1977	08/1985	PRD 1148
Granada	6	2792	118	08/1977	08/1981	PRB 1148
Granada	6	2792	97	06/1981	08/1985	PYU 1148
Granada	6	2792	110	10/1982	08/1985	PRC 1148
Grand C-Max	3	998	74	10/2012	06/2019	B3DA 994 M2DA 996 M2DC SFDA
Grand C-Max	3	998	92	10/2012	06/2019	M1DA 994 M1DD

FORD	ccm	kW	→	→		
Grand C-Max	4	1498	110	03/2015	06/2019	M8DB 1016 M8DF
Grand C-Max	4	1498	134	03/2015	06/2019	M9DB 1016
Grand C-Max	4	1596	63	12/2010	06/2019	XTDA 1034
Grand C-Max	4	1596	77	12/2010	06/2019	IQDA 1034 IQDB
Grand C-Max	4	1596	92	12/2010	06/2019	PNDA 1034 PNDD
Grand C-Max	4	1596	110	12/2010	06/2019	JQDA 1032 JQDB
Grand C-Max	4	1596	134	12/2010	06/2019	JTDA 1032 JTDB
Grand C-Max TDCi	4	1499	70	03/2015	06/2019	XXDA 1020 XXDC
Grand C-Max TDCi	4	1499	88	03/2015	06/2019	XWDA 1020 XWDB XWDC XWDD XWDE
Grand C-Max TDCi	4	1560	70	12/2010	06/2019	T3DA 1026 T3DB
Grand C-Max TDCi	4	1560	85	12/2010	06/2019	T1DA 1026 T1DB
Grand C-Max TDCi	4	1997	103	12/2010	06/2019	UFDB 1104
Grand C-Max TDCi	4	1997	120	12/2010	06/2019	TXDB 1104
Grand C-Max TDCi	4	1997	85	02/2011	06/2019	TYDA 1104
Grand C-Max TDCi	4	1997	100	02/2011	06/2019	UKDB 1104
Grand C-Max TDCi	4	1997	110	03/2015	06/2019	T7DB 1104 T7DC
Grand C-Max TDCi	4	1997	125	03/2015	06/2019	T8DE 1104
Ka	3	997	63	08/2014	12/2018	P4JA 996
Ka	4	999	39	01/1997	07/1999	ZH10JRB 998
Ka	4	999	38	07/1997	09/1999	ZH10JRB 998
Ka	4	999	48	09/1999	11/2008	ZH10JRY 998
Ka	4	1242	51	10/2008	05/2016	169A4000 1000 AAAA FP4
Ka	4	1299	37	09/1996	10/2002	JJB 1006
Ka	4	1299	44	09/1996	11/2008	BAA 1004 J4D 1006 J4K J4M J4N J4P J4S

FORD

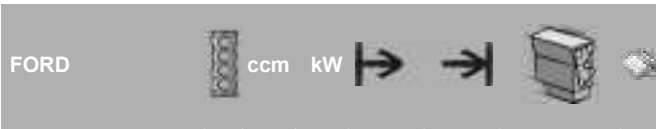

FORD	ccm	kW	→	→	→	→
Ka	4	1299	36	06/1998	11/2008	JJD 1006 JFJ JJG JJH JJL
Ka	4	1299	51	08/2002	11/2008	A9A 1004 A9B
Ka	4	1499	81	08/2014		C154CSG 1018
Ka	4	1499	82	09/2015	01/2018	UEJB 1018
Ka	4	1499	77	01/2017		UEJB 1018
Ka	4	1598	70	02/2008		CDB 1044 CDC
Ka	4	1599	70	02/2001	11/2008	CDB 1044 CDC
Ka TDCi	4	1248	55	10/2008	05/2016	169A1000 1004 BAAA FD4
Ka TDCi	4	1498	74	09/2015		15DSOX 1020
Ka TDCi	4	1499	66	02/2018		15DSOX 1020
Ka TDCi	4	1499	70	02/2018		15DSOX 1020
Kuga	4	1499	110	09/2014		M8MA 1016 M8MB M8MC M8MD M8ME
Kuga	4	1499	134	09/2014		M9MA 1016 M9MB M9MC M9MD
Kuga	4	1499	132	10/2015		M9MA 1016
Kuga	4	1499	88	01/2016		BNMA 1016 BNMB 1022 BNMC ZTDA
Kuga	4	1499	129	08/2018		M9ME 1016
Kuga	4	1596	132	10/2012	04/2015	JTMA 1032
Kuga	4	1596	130	01/2013		JTMA 1032
Kuga	4	1596	110	03/2013	09/2014	JQMA 1032 JQMB
Kuga	4	1596	134	03/2013	09/2014	JTMA 1032
Kuga	4	1995	110	07/2019		YLDC 1098
Kuga	4	1995	140	07/2019		YMDA 1098
Kuga	4	1996	110	02/2021		YLDC 1098
Kuga	4	1999	177	01/2014		R9MA 1114 R9MB
Kuga	4	1999	178	08/2017		R9MA 1114
Kuga	4	2488	110	01/2014		YTMA 1136



Kuga	5	2521	147	02/2008	11/2012	HYDB 1144 HYDC
Kuga	5	2522	147	02/2008	11/2012	HYDB 1144 HYDC
Kuga TDCi	4	1499	88	07/2016		XWMB 1020 XWMC
Kuga TDCi	4	1997	100	03/2008		G6DG 1102 UKDA 1104 UKMA
Kuga TDCi	4	1997	103	03/2010		UFDA 1104 UFMA
Kuga TDCi	4	1997	120	03/2010	11/2012	TXDA 1104
Kuga TDCi	4	1997	88	06/2019		XRMA 1104 XRMB
Kuga TDCi	4	1998	120	03/2010	09/2014	TXDA 1104 TXMA
Kuga TDCi	4	1998	85	03/2013		TYMA 1104
Kuga TDCi	4	1998	88	09/2014	06/2019	XRMA 1104 XRMB XRMC
Kuga TDCi	4	1998	110	09/2014		T7MA 1104 T7MB T7MC T7MD
Kuga TDCi	4	1998	132	09/2014		T8MA 1104 T8MB T8MC
Maverick	4	1989	91	02/2001		YF 1092
Maverick	4	2261	110	03/2004		GZ 1128
Metrostar	4	1999	107	10/2000	02/2007	ZH20CJBB 1112
Metrostar	6	2495	125	10/2000	02/2007	LCBD 1138
Mondeo	3	998	92	02/2015		M1CA 994 M1CB
Mondeo	3	999	92	02/2015		M1CA 994 M1CB
Mondeo	4	1499	118	09/2014		UNCA 1016 UNCB UNCE UNCF
Mondeo	4	1499	121	05/2018		UNCN 1016
Mondeo	4	1596	81	03/2007	01/2015	RHBA 1034
Mondeo	4	1596	92	03/2007	01/2015	PNBA 1034
Mondeo	4	1596	88	03/2010	01/2015	KGBA 1034
Mondeo	4	1596	118	11/2010	01/2015	JTBA 1032 JTBB
Mondeo	4	1597	66	02/1993	09/2000	L1F 1036 L1J
Mondeo	4	1597	65	07/1994	08/1996	L1J 1036



FORD	ccm	kW	→	→		
Mondeo	4	1597	70	05/1998	09/2000	L1L 1038 L1N L1Q
Mondeo	4	1796	85	02/1993	09/2000	RKA 1080 RKB RKF RKH RKJ RKK
Mondeo	4	1796	82	01/1994	08/1996	RKB 1080
Mondeo	4	1798	81	10/2000	03/2007	CGBA 1082 CGBB
Mondeo	4	1798	92	10/2000	03/2007	CHBA 1082 CHBB
Mondeo	4	1976	149	03/2010	01/2015	TNBA 1114
Mondeo	4	1988	97	01/1993	08/1996	NGA 1094
Mondeo	4	1988	100	02/1993	08/1996	NGA 1094
Mondeo	4	1988	96	08/1996	09/2000	NGA 1094 NGB NGC NGD
Mondeo	4	1995	88	01/2019		BCCD 1098
Mondeo	4	1995	110	01/2019		YLCC 1098
Mondeo	4	1995	140	01/2019		YMCC 1098
Mondeo	4	1999	106	10/2000	03/2007	CJBA 1112
Mondeo	4	1999	107	10/2000	01/2015	AOBA 1112 AOBC CJBA CJBB TBBA TBBB
Mondeo	4	1999	149	03/2010		TNBA 1114 TNCA 1116 TNCB TNCD TNCF
Mondeo	4	1999	176	03/2010		R9CB 1112 R9CF 1114 R9CH TPBA
Mondeo	4	1999	140	09/2014		UACA 1118
Mondeo	4	1999	103	10/2014		UACA 1118 UACC
Mondeo	4	1999	146	05/2015		TNCC 1116
Mondeo	4	2261	118	07/2007	01/2015	SEBA 1128
Mondeo	6	2451	125	10/2000	03/2007	LCBD 1138
Mondeo	4	2488	127	09/2012		YTMA 1136
Mondeo	4	2488	125	05/2015		YTMA 1136
Mondeo	4	2489	110	05/2015		S7CB 1136

FORD	ccm	kW	→	→		
Mondeo	6	2495	151	05/1999	09/2000	SGA 1136
Mondeo	6	2495	125	10/1999	03/2007	LCBD 1136 SEB 1138 SEC
Mondeo	5	2521	162	03/2007	01/2015	HUBA 1144
Mondeo	6	2544	125	07/1994	09/2000	SEA 1144
Mondeo	6	2967	166	04/2002	03/2007	MEBA 1150
Mondeo	6	2967	150	09/2004	03/2007	REBA 1150
Mondeo TD	4	1753	65	06/1993	08/1996	RFM 1064 RFN 1066
Mondeo TD	4	1753	66	10/1995	09/2000	RFM 1064 RFN 1066
Mondeo TDCi	4	1499	88	03/2015		UGCC 1020 XUCA
Mondeo TDCi	4	1560	85	12/2010		NGCA 1026 T1BA T1BB T1BC U3CA
Mondeo TDCi	4	1753	74	03/2007	01/2015	FFBA 1052
Mondeo TDCi	4	1753	92	06/2007	01/2015	KHBA 1052 QYBA
Mondeo TDCi	4	1997	96	03/2007	01/2015	AZBA 1102
Mondeo TDCi	4	1997	100	03/2007	12/2014	AZBC 1102 UKBA 1104 UKBB
Mondeo TDCi	4	1997	103	03/2007	01/2015	QXBA 1102 QXBB 1104 UFBA UFBB
Mondeo TDCi	4	1997	85	11/2007	01/2015	KLBA 1102 LPBA 1104 TYBA
Mondeo TDCi	4	1997	120	03/2010	01/2015	TXBA 1104 TXBB
Mondeo TDCi	4	1998	92	10/2000	03/2007	PD20FMCR 1110
Mondeo TDCi	4	1998	96	10/2001	03/2007	FMBA 1110 N7BA
Mondeo TDCi	4	1998	110	09/2014		T7CA 1104 T7CC T7CD T7CE T7CF T7CN T7CP T7CQ
Mondeo TDCi	4	1998	132	09/2014		T8CA 1104 T8CB T8CC T8CD T8CL
Mondeo TDCi	4	1998	154	03/2015		T9CA 1104

FORD



Mondeo TDCi	4	2179	129	03/2008	10/2010	Q4BA 1120
Mondeo TDCi	4	2179	147	07/2010	01/2015	KNBA 1120
Mondeo TDCi	4	2198	110	09/2004	03/2007	QJBC 1122 QJBD
Mondeo TDCi	4	2198	114	09/2004	03/2007	QJBA 1122 QJBB
Mondeo TDDi/TDCi	4	1998	66	10/2000	03/2007	D5BA 1106 SDBA
Mondeo TDDi/TDCi	4	1998	85	10/2000	03/2007	D6BA 1108 HJBA HJBB HJBC
Orion	4	1296	51	07/1983	07/1988	JPA 1004
Orion	4	1297	44	12/1985	07/1990	JBB 1006 JLA JLB
Orion	4	1299	44	07/1990	12/1993	J4B 1008 J6A
Orion	4	1391	52	07/1990	12/1993	F6F 1014 F6G
Orion	4	1392	55	12/1985	07/1990	FUA 1014
Orion	4	1392	54	01/1986	12/1993	F6B 1014 F6D FUC FUH
Orion	4	1392	52	03/1986	07/1990	FUAA 1014
Orion	4	1597	58	07/1983	03/1986	LP1 1042 LPA
Orion	4	1597	77	07/1983	07/1990	LR1 1040 LRA 1042 LRB
Orion	4	1597	66	12/1985	12/1993	L1E 1038 L4B 1040 LUC 1042
Orion	4	1597	75	02/1986	07/1990	LJB 1040
Orion	4	1597	65	03/1986	07/1990	LUG 1042
Orion	4	1598	66	07/1990	12/1992	LUJ 1044 LUK
Orion	4	1598	77	07/1990	09/1992	LJF 1040
Orion	4	1608	40	02/1984	01/1989	LTA 1044 LTC
Orion	4	1753	44	01/1989	12/1993	RTA 1068 RTB 1070 RTE RTF RTH
Orion	4	1796	96	01/1992	12/1993	RQB 1078
Orion	4	1796	77	02/1992	12/1993	RDA 1078

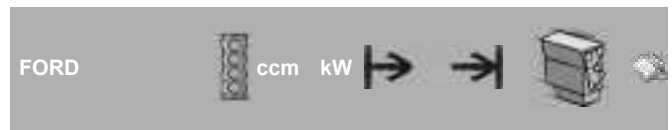

Orion TD	4	1753	66	03/1992	12/1993	RFD 1056 RFK
P 100	4	1993	57	10/1987	12/1992	NAE 1096
P 100 TD	4	1753	55	10/1987	12/1992	RFA 1060
Puma	3	999	92	12/2021		B7JG 996
Puma	4	1388	66	11/1997	10/2000	FHD 1008 FHF
Puma	4	1596	76	08/2000	06/2002	L1W 1034
Ranger	4	1796	85	06/1999	02/2002	RKA 1080
Ranger	4	2488	122	11/2011		GBVAK 1134
Ranger	4	2499	80	06/2005	11/2011	WL-T 1142
Ranger	4	2500	57	10/1999	04/2002	WL 1142
Ranger TD	4	2500	80	10/1999	06/2006	WL-T 1142
Ranger TD	4	2500	62	04/2002	06/2006	WL-T 1142
Ranger TDCi	4	2198	88	04/2011		ENPF 1126 GBVAJPF
Ranger TDCi	4	2198	92	04/2011		ENQW 1126 GBVAJQW
Ranger TDCi	4	2198	110	04/2011		ENQJ 1126 GBVAJQJ
Ranger TDCi	4	2198	118	05/2015		GBVAJQJ 1126 T22DD0P
Ranger TDCi	5	3198	147	04/2011		ENSA 1150 P5-AT 1152 SA2R SA2S SA2W SAFA
Scorpio	4	1993	77	04/1985	08/1989	NEL 1096
Scorpio	4	1993	85	04/1985	09/1994	NRA 1098 NRI
Scorpio	4	1993	74	10/1985	12/1990	NER 1096 NRC
Scorpio	4	2295	108	06/1996	08/1998	Y5A 1130
Scorpio	4	2498	51	12/1985	12/1994	STR 1142
Scorpio	4	2499	51	10/1990	08/1992	STR 1142
Scorpio	6	2792	110	04/1985	11/1986	PRE 1148
Scorpio TD	4	2498	68	06/1988	07/1993	SFA 1140 SFB
Scorpio TD	4	2500	85	08/1993	08/1998	SCB 1142 SCC 1144
Scorpio TD	4	2500	92	09/1996	08/1998	VM 1144
Sierra	4	1593	55	08/1982	12/1986	LSD 1042
Sierra	4	1593	51	10/1982	02/1987	LSDA 1042



FORD	ccm	kW	→	→	→	→
Sierra	4	1597	58	08/1984	12/1986	LSD 1042
Sierra	4	1597	55	01/1987	02/1993	LSE 1042
Sierra	4	1597	53	01/1988	02/1993	LSF 1042
Sierra	4	1597	59	10/1989	02/1993	L6B 1040
Sierra	4	1598	59	10/1989	02/1993	L6B 1040
Sierra	4	1769	64	05/1988	02/1993	R2C 1076
Sierra	4	1796	66	01/1987	05/1988	R2A 1076
Sierra	4	1993	77	08/1982	02/1993	NES 1096 NET 1098
Sierra	4	1993	85	03/1985	02/1993	N4A 1098 N4I NR2 NRB
Sierra	4	1993	74	10/1985	02/1993	N4B 1096 NE5 1098 NEJ NRD
Sierra	4	2304	49	08/1982	02/1993	YTR 1130 YTT
Sierra	6	2792	105	08/1982	02/1993	PR6 1148 PR8
Sierra	6	2792	107	08/1982	02/1993	PR5 1148 PR6 PR7
Sierra	6	2792	110	08/1982	09/1989	PRG 1148 PRT
Sierra TD	4	1753	55	08/1988	02/1993	RFA 1060 RFB RFL
S-Max	4	1498	118	01/2015	06/2018	UNCI 1016 UNCJ UNCK
S-Max	4	1499	121	07/2018		C15HDTX 1016 UNCP
S-Max	4	1596	118	02/2011	12/2014	JTWA 1032 JTWB
S-Max	4	1995	88	07/2018		YNCA 1098
S-Max	4	1995	110	07/2018		YMCB 1098
S-Max	4	1995	140	07/2018		BCCC 1098
S-Max	4	1995	176	07/2018		YLCB 1098
S-Max	4	1999	107	05/2006	12/2014	AODE 1112 AOWA AOWB TBWA TBWB
S-Max	4	1999	149	03/2010	12/2014	TNWA 1116
S-Max	4	1999	146	07/2010	12/2014	TNWB 1116

FORD	ccm	kW	→	→	→	→
S-Max	4	1999	176	07/2010		R9CD 1112 R9CI 1116 TPWA
S-Max	4	2261	118	07/2007	12/2014	SEWA 1128
S-Max	5	2521	162	05/2006	12/2014	HUWA 1144
S-Max TDCi	4	1560	85	02/2011	12/2014	T1WA 1026 T1WB
S-Max TDCi	4	1753	92	05/2006	12/2014	QYWA 1052
S-Max TDCi	4	1753	74	01/2007	12/2010	FFWA 1052
S-Max TDCi	4	1997	96	05/2006	12/2014	AZWA 1102
S-Max TDCi	4	1997	100	05/2006	12/2014	AZWC 1102 UKWA 1104
S-Max TDCi	4	1997	103	05/2006	12/2014	QXWA 1102 QXWB 1104 QXWC UFWA
S-Max TDCi	4	1997	85	01/2007	12/2014	TYWA 1104
S-Max TDCi	4	1997	120	03/2010	12/2014	TXWA 1104
S-Max TDCi	4	1997	88	01/2015	06/2018	UFCA 1104 UFCB UFCD
S-Max TDCi	4	1997	110	01/2015	06/2018	T7CI 1104 T7CJ T7CK T7CL
S-Max TDCi	4	1997	132	01/2015	06/2018	T8CG 1104 T8CH T8CI T8CJ
S-Max TDCi	4	1997	154	01/2015	06/2018	T9CB 1104 T9CC
S-Max TDCi	4	2179	129	03/2008	12/2012	Q4WA 1120
S-Max TDCi	4	2179	147	07/2010	12/2014	KNWA 1120
Street Ka	4	1599	70	05/2003	07/2005	CDRA 1044 CDRB
Taurus	4	1576	53	08/1970	02/1976	LCJ 1028
Taurus	4	1576	65	08/1970	02/1976	LE 1028
Taurus	4	1593	53	01/1970	07/1979	LCJ 1028
Taurus	4	1593	50	01/1974	08/1979	LAD 1028
Taurus	4	1593	65	08/1976	07/1982	LE 1028
Taurus	4	1593	66	09/1976	08/1979	LE 1028
Taurus	4	1593	51	07/1979	07/1982	LAR 1028
Taurus	4	1593	54	07/1979	07/1982	LCJ 1028
Taurus	4	1593	68	09/1979	12/1982	LE 1028
Taurus	4	1993	72	08/1973	07/1979	NEE 1096 NEG

FORD

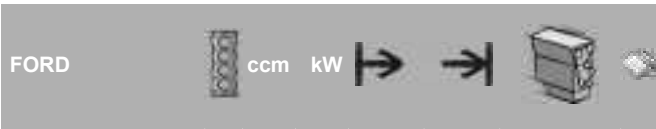

FORD	ccm	kW	→	→	→	→
Taurus	4	1993	64	07/1979	07/1982	NER 1096
Taurus	4	1993	74	07/1979	07/1982	NER 1096
Taurus	4	1994	64	12/1975	07/1976	OHC LC 1096
Taurus	4	1994	70	08/1976	07/1979	NEG 1096 OHC TL 20 H 1098
Tourneo	4	1995	96	05/2019		BKFC 1100 BKFD
Tourneo	4	1995	136	05/2019		BCFA 1100 BCFB BCFC BCFD
Tourneo Connect	3	998	74	11/2013		B3GA 994 M2GA M2GB SFCB
Tourneo Connect	4	1499	55	05/2018		BEGA 1022
Tourneo Connect	4	1499	74	05/2018		Z2GA 1022
Tourneo Connect	4	1499	88	05/2018		ZTGA 1022
Tourneo Connect	4	1596	110	11/2013		JQGA 1032
Tourneo Connect	4	1796	85	06/2002	12/2013	EYPA 1078 EYPB EYPC EYPD
Tourneo Connect	4	1999	102	09/2009	12/2013	C20HDEX 1110
Tourneo Connect TDCi	4	1499	55	05/2015		XUGA 1018
Tourneo Connect TDCi	4	1499	74	05/2015		XVGA 1018 XVGB XVGC XXGA
Tourneo Connect TDCi	4	1499	88	05/2015		XWGA 1018 XWGB XWGC
Tourneo Connect TDCi	4	1499	70	08/2016		XXGA 1018
Tourneo Connect TDCi	4	1560	55	09/2013		UBGA 1026
Tourneo Connect TDCi	4	1560	70	09/2013		TZGA 1026 TZGB
Tourneo Connect TDCi	4	1560	85	09/2013		T1GA 1026
Tourneo Connect TDCi	4	1753	55	06/2002	12/2013	BHPA 1054 P7PA P7PB R2PA

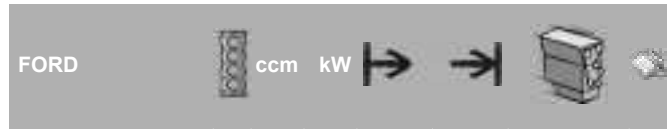

FORD	ccm	kW	→	→	→	→
Tourneo Connect TDCi	4	1753	66	06/2002	12/2013	HCPA 1054 HCPB HCPC HCPD P9PA P9PB P9PC P9PD R3PA RWPE RWPF
Tourneo Connect TDCi	4	1753	81	08/2006	12/2013	RWPA 1054 RWPB RWPC RWPD
Tourneo Courier	3	998	74	02/2014		SFCA 994 SFCB SFCC SFCD SFCE SFCF
Tourneo Courier TDCi	4	1499	55	02/2014		UGCA 1020 UGCB XUCC XUCD XUCE XWCA XWCB
Tourneo Courier TDCi	4	1499	70	05/2015		XVCA 1020 XVCB XVCC XVCD
Tourneo Courier TDCi	4	1499	74	04/2018		XXCA 1020 XXCB XXCC
Tourneo Courier TDCi	4	1560	70	02/2014		T3CA 1026 T3CB T3CC
Tourneo TDCi	4	1995	77	12/2015		BJFA 1100 BJFB YLF6 YLFA YLFB YLFS
Tourneo TDCi	4	1995	96	12/2015		BKFA 1100 BKFB YMF6 YMFA YMF6 YMF7
Tourneo TDCi	4	1995	125	12/2015		BLFA 1100 BLFB YNF6 YNFA YNFB YNFS
Tourneo TDCi	4	2198	74	04/2012	12/2015	DRF4 1122 DRFF DRFG
Tourneo TDCi	4	2198	92	04/2012	12/2015	CYF4 1122 CYFF



FORD	ccm	kW	→	→	→	→
Tourneo TDCi	4	2198	114	04/2012	12/2015	CVFF 1122
Transit	4	1993	43	11/1977	07/1982	4RC 1098
Transit	4	1993	55	11/1977	10/1986	4RC 1098
Transit	4	1993	57	11/1977	09/1992	4RC 1096 N6T 1098
Transit	4	1993	56	10/1985	03/1991	NAW 1096 NAX
Transit	4	1993	60	10/1985	03/1991	N6TS 1096
Transit	4	1993	66	04/1991	09/1994	NBA 1098
Transit	4	1994	57	09/1985	09/1992	NAT 1096 NAV
Transit	4	1994	72	09/1991	08/1994	NCA 1098
Transit	4	1995	77	12/2015		BJFA 1100 BJFB BJFC BJFD YLF6 YLFA YLFB YLFS
Transit	4	1995	96	12/2015		BKFA 1100 BKFB BKFC BKFD BKRB YMF6 YMFA YMF6 YMFB YMFS YMHA
Transit	4	1995	125	12/2015		BLFA 1100 BLFB BLFC BLFD BLHA BLRA BLRB YNF6 YNFA YNFB YNFS
Transit	4	1995	136	05/2019		BCFA 1100 BCFB BCFC BCFD BCRA BCRB
Transit	4	1995	110	10/2021		P0FA 1100 P0FB
Transit	4	2261	100	04/2006	08/2014	GZFC 1128
Transit	4	2261	107	04/2006	08/2014	GZFA 1128 GZFB GZFC
Transit	4	2295	107	08/2000	05/2006	E5FA 1130 E5FC
Transit	4	2295	105	03/2001	03/2006	E5FC 1130

FORD	ccm	kW	→	→	→	→
Transit	4	2496	50	10/1983	09/1991	4AB 1138
Transit	4	2496	60	10/1985	03/1991	4AE 1138
Transit	4	2496	52	09/1988	09/1992	4BA 1138 4CA
Transit Connect	3	998	74	02/2013		B3GA 994 B3GB M2GA M2GB
Transit Connect	4	1499	88	05/2015		ZTGA 1022
Transit Connect	4	1499	55	05/2018		BEGA 1022
Transit Connect	4	1499	74	05/2018		Z2GA 1022
Transit Connect	4	1596	133	09/2013		JQGA 1032
Transit Connect	4	1596	110	11/2013		JQGA 1032
Transit Connect	4	1796	85	06/2002	12/2013	EYPA 1078 EYPC EYPD
Transit Connect	4	1999	101	09/2009		C20HDEX 1110
Transit Connect	4	1999	112	01/2019	12/2019	C20HDEX 1110
Transit Connect	4	1999	121	01/2020		C20HDEX 1110
Transit Connect	4	2488	126	09/2013		S7GA 1134 S7GB
Transit Connect DI	4	1753	55	06/2002	12/2013	BHPA 1054 P7PA P7PB R2PA
Transit Connect TDCi	4	1499	74	05/2015		XVGA 1018 XVGB XVGC XXGA
Transit Connect TDCi	4	1499	88	05/2015		XWGA 1018 XWGB XWGC
Transit Connect TDCi	4	1499	55	08/2015		XUGA 1018
Transit Connect TDCi	4	1499	70	03/2016		XXGA 1018
Transit Connect TDCi	4	1560	55	02/2013		UBGA 1026
Transit Connect TDCi	4	1560	70	02/2013		TZGA 1026 TZGB
Transit Connect TDCi	4	1560	85	02/2013		T1GA 1026
Transit Connect TDCi	4	1753	66	06/2002	12/2013	HCPA 1054 HCPB HCPC HCPD P9PA P9PB P9PC P9PD R3PA RWPE RWPF



FORD ccm kW

Transit TDCi	4	2198	92	09/2011	12/2018	CY14 1122 CY24 1126 CYF4 CYF5 CYFA CYFB CYFC CYFD CYFF CYFG CYR5 CYRA CYRB CYRC USF6 USR6
---------------------	---	------	----	---------	---------	--

Transit TDCi	4	2198	100	09/2011	08/2014	USRA 1126 USRB
---------------------	---	------	-----	---------	---------	-------------------

Transit TDCi	4	2198	74	10/2011	12/2018	DRF4 1122 DRF5 1126 DRFA DRFB DRFC DRFD DRFE DRFF DRFG DRR5 DRRA DRRB DRRC
---------------------	---	------	----	---------	---------	--

Transit TDCi	4	2198	114	10/2011	12/2018	CV24 1122 CVF5 1126 CVFF CVR5 CVRA CVRB CVRC UYR6
---------------------	---	------	-----	---------	---------	--

Transit TDCi	4	2198	99	08/2013	12/2018	UHR5 1126
---------------------	---	------	----	---------	---------	-----------

Transit TDCi	4	2402	101	03/2004	05/2006	H9FA 1132
---------------------	---	------	-----	---------	---------	-----------

Transit TDCi	4	2402	74	04/2006	08/2014	PHFA 1132 PHFC
---------------------	---	------	----	---------	---------	-------------------

Transit TDCi	4	2402	85	04/2006	08/2014	JXFA 1132 JXFC
---------------------	---	------	----	---------	---------	-------------------

Transit TDCi	4	2402	103	04/2006	08/2014	H9FB 1132 H9FD
---------------------	---	------	-----	---------	---------	-------------------

Transit TDCi	4	2402	88	01/2007	12/2011	SWFA 1132
---------------------	---	------	----	---------	---------	-----------

Transit TDCi	5	3199	147	09/2007	08/2014	SAFA 1152 SAFB
---------------------	---	------	-----	---------	---------	-------------------

Transit TDE	4	2402	92	07/2001	05/2006	DOFA 1132
--------------------	---	------	----	---------	---------	-----------

Transit TDE	4	2402	85	03/2004	05/2006	FXFA 1132
--------------------	---	------	----	---------	---------	-----------

Transit Tourneo	4	2496	55	08/1994	06/2000	4HA 1140
------------------------	---	------	----	---------	---------	----------

Transit Tourneo	4	2496	63	11/1994	12/2000	4GA 1138 4GB 4GC 4GD
------------------------	---	------	----	---------	---------	-------------------------------

FORD ccm kW

Transit Tourneo	4	2496	74	04/1998	12/2000	4EB 1138 4EC
------------------------	---	------	----	---------	---------	-----------------

Transit Tourneo DI	4	1998	74	06/2000	03/2005	ABFA 1106
---------------------------	---	------	----	---------	---------	-----------

Transit Tourneo DI	4	2496	51	11/1994	12/2000	4FA 1138 4FB 4FC 4FD
---------------------------	---	------	----	---------	---------	-------------------------------

Transit Tourneo DI	4	2496	56	11/1994	12/2000	4HA 1140 4HB 4HC
---------------------------	---	------	----	---------	---------	------------------------

Transit Tourneo TDCi	4	1998	55	06/2000	08/2003	D3FA 1106
-----------------------------	---	------	----	---------	---------	-----------

Transit Tourneo TDCi	4	1998	92	03/2002	03/2006	FIFA 1108
-----------------------------	---	------	----	---------	---------	-----------

Transit Tourneo TDCi	4	2198	81	07/2006	08/2014	QVFA 1124
-----------------------------	---	------	----	---------	---------	-----------

Transit Tourneo TDCi	4	2198	96	07/2006	08/2014	QWFA 1124
-----------------------------	---	------	----	---------	---------	-----------

Transit Tourneo TDCi	4	2198	103	10/2007	08/2014	PGFA 1124 PGFB UHFA UHFB UHFC
-----------------------------	---	------	-----	---------	---------	---

Transit Tourneo TDCi	4	2198	85	10/2008	08/2014	SRFA 1124 SRFB SRFC SRFD SRFE
-----------------------------	---	------	----	---------	---------	---

Transit Tourneo TDCi	4	2198	92	10/2011	08/2014	CYFA 1122 CYFB CYFC CYFD
-----------------------------	---	------	----	---------	---------	-----------------------------------

FORD

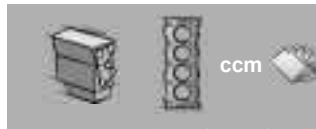
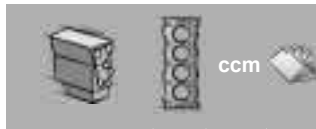

15DSOX	4	1499	1020
169A1000	4	1248	1004
169A4000	4	1242	1000
1Z	4	1896	1084
4AB	4	2496	1138
4AE	4	2496	1138
4BA	4	2496	1138
4BB	4	2496	1138
4BC	4	2496	1138
4CA	4	2496	1138
4CB	4	2496	1138
4CC	4	2496	1138
4DA	4	2496	1138
4EA	4	2496	1138
4EB	4	2496	1138
4EC	4	2496	1138
4ED	4	2496	1138
4FA	4	2496	1138
4FB	4	2496	1138
4FC	4	2496	1138
4FD	4	2496	1138
4GA	4	2496	1138
4GB	4	2496	1138
4GC	4	2496	1138
4GD	4	2496	1138
4GE	4	2496	1138
4GF	4	2496	1138
4HA	4	2496	1140
4HB	4	2496	1140
4HC	4	2496	1140
4HD	4	2496	1140
4RC	4	1993	1098
A9A	4	1299	1004
A9B	4	1299	1004
A9JA	4	1299	1004
A9JB	4	1299	1004
A9JD	4	1299	1004

AAA	6	2792	1146
AAAA	4	1242	1000
ABFA	4	1998	1106
AEDA	4	1499	1020
AFN	4	1896	1084
AHU	4	1896	1086
AMY	6	2792	1146
ANU	4	1896	1086
AOBA	4	1999	1112
AOBC	4	1999	1112
AODA	4	1999	1112
AODB	4	1999	1112
AODE	4	1999	1112
AOWA	4	1999	1112
AOWB	4	1999	1112
ASDA	4	1388	1008
ASDB	4	1388	1008
ASZ	4	1896	1088
AUY	4	1896	1088
AVG	4	1896	1090
AYL	6	2792	1146
AZBA	4	1997	1102
AZBC	4	1997	1102
AZWA	4	1997	1102
AZWC	4	1997	1102
B3DA	3	999	996
B3GA	3	998	994
B3GB	3	998	994
B7JG	3	999	996
BAA	4	1299	1004
BAAA	4	1248	1004
BAJA	4	1299	1004
BCCC	4	1995	1098
BCCD	4	1995	1098
BCDA	4	1995	1098
BCFA	4	1995	1100
BCFB	4	1995	1100

BCFC	4	1995	1100
BCFD	4	1995	1100
BCRA	4	1995	1100
BCRB	4	1995	1100
BEGA	4	1499	1022
BHDA	4	1753	1046
BHDB	4	1753	1046
BHPA	4	1753	1054
BJFA	4	1995	1100
BJFB	4	1995	1100
BJFC	4	1995	1100
BJFD	4	1995	1100
BJRA	4	1995	1100
BJRB	4	1995	1100
BKFA	4	1995	1100
BKFB	4	1995	1100
BKFC	4	1995	1100
BKFD	4	1995	1100
BKRA	4	1995	1100
BKRB	4	1995	1100
BLFA	4	1995	1100
BLFB	4	1995	1100
BLFC	4	1995	1100
BLFD	4	1995	1100
BLHA	4	1995	1100
BLRA	4	1995	1100
BLRB	4	1995	1100
BNMA	4	1498	1016
BNMB	4	1498	1016
BNMC	4	1498	1016
BTB	4	1896	1090
C	4	1993	1096
C154CSG	4	1499	1018
C15HDTX	4	1498	1016
C16HDEX	4	1596	1028
C16HDEZ	4	1596	1028
C20HDEX	4	1999	1110

C4E	4	999	998
C9DA	4	1753	1048
C9DB	4	1753	1048
C9DC	4	1753	1048
CCA	4	1599	1044
CDB	4	1599	1044
CDC	4	1599	1044
CDRA	4	1599	1044
CDRB	4	1599	1044
CGBA	4	1798	1082
CGBB	4	1798	1082
CHBA	4	1798	1082
CHBB	4	1798	1082
CJBA	4	1999	1112
CJBB	4	1999	1112
CPJA	4	999	998
CSDA	4	1798	1082
CSDB	4	1798	1082
CV24	4	2198	1126
CVF5	4	2198	1122
CVFF	4	2198	1122
CVR5	4	2198	1126
CVRA	4	2198	1126
CVRB	4	2198	1126
CVRC	4	2198	1126
CY14	4	2198	1122
CY24	4	2198	1126
CYF4	4	2198	1122
CYF5	4	2198	1122
CYFA	4	2198	1122
CYFB	4	2198	1122
CYFC	4	2198	1122
CYFD	4	2198	1122
CYFF	4	2198	1122
CYFG	4	2198	1122
CYR5	4	2198	1126
CYRA	4	2198	1126



CYRB	4	2198	1126
CYRC	4	2198	1126
D18TRFL	4	1753	1060
D2FA	4	2402	1132
D2FB	4	2402	1132
D2FE	4	2402	1132
D3FA	4	1998	1106
D4FA	4	2402	1132
D5BA	4	1998	1106
D6BA	4	1998	1108
DHA	4	1242	1000
DHB	4	1242	1000
DHC	4	1242	1000
DHD	4	1242	1000
DHE	4	1242	1000
DHF	4	1242	1000
DHG	4	1242	1000
DOFA	4	2402	1132
DRF4	4	2198	1122
DRF5	4	2198	1122
DRFA	4	2198	1122
DRFB	4	2198	1122
DRFC	4	2198	1122
DRFD	4	2198	1122
DRFE	4	2198	1122
DRFF	4	2198	1122
DRFG	4	2198	1122
DRR5	4	2198	1126
DRRA	4	2198	1126
DRRB	4	2198	1126
DRRC	4	2198	1126
E5FA	4	2295	1130
E5FC	4	2295	1130
E5SA	4	2295	1130
E5SB	4	2295	1130
EDBA	4	1988	1092
EDBB	4	1988	1092



EDBC	4	1988	1092
EDBD	4	1988	1092
EDDB	4	1988	1092
EDDC	4	1988	1092
EDDD	4	1988	1092
EDDF	4	1988	1092
ENPF	4	2198	1126
ENQJ	4	2198	1126
ENQW	4	2198	1126
ENSA	5	3198	1150
EYDB	4	1796	1078
EYDC	4	1796	1078
EYDD	4	1796	1078
EYDE	4	1796	1078
EYDF	4	1796	1078
EYDG	4	1796	1078
EYDI	4	1796	1078
EYDJ	4	1796	1078
EYDL	4	1796	1078
EYPA	4	1796	1078
EYPB	4	1796	1078
EYPC	4	1796	1078
EYPD	4	1796	1078
F3FA	4	1998	1106
F4A	4	1392	1012
F4B	4	1392	1012
F4FA	4	2402	1132
F6A	4	1392	1014
F6B	4	1392	1014
F6C	4	1392	1014
F6D	4	1392	1014
F6E	4	1392	1014
F6F	4	1392	1014
F6G	4	1392	1014
F6JA	4	1399	1014
F6JB	4	1399	1014
F6JC	4	1399	1014



F6JD	4	1399	1014
F9DA	4	1753	1050
F9DB	4	1753	1050
FD4	4	1248	1004
FFBA	4	1753	1052
FFDA	4	1753	1048
FFWA	4	1753	1052
FHA	4	1388	1008
FHD	4	1388	1008
FHE	4	1388	1008
FHF	4	1388	1008
FIFA	4	1998	1108
FMBA	4	1998	1110
FP4	4	1242	1000
FSJB	3	1084	998
FUA	4	1392	1014
FUAA	4	1392	1014
FUB	4	1392	1014
FUBA	4	1392	1014
FUC	4	1392	1014
FUD	4	1392	1014
FUF	4	1392	1014
FUG	4	1392	1014
FUH	4	1392	1014
FUJ	4	1392	1014
FUJA	4	1242	1002
FUJB	4	1242	1002
FVKB	4	1388	1008
FXDA	4	1388	1010
FXDB	4	1388	1010
FXDC	4	1388	1010
FXDD	4	1388	1010
FXFA	4	2402	1132
FXJA	4	1388	1010
FXJB	4	1388	1010
FXJC	4	1388	1010
FYDA	4	1596	1030



FYDB	4	1596	1030
FYDC	4	1596	1030
FYDD	4	1596	1030
FYDH	4	1596	1030
FYJA	4	1596	1030
FYJB	4	1596	1030
FYJC	4	1596	1030
G6A	4	1117	1000
G6DA	4	1997	1102
G6DB	4	1997	1102
G6DC	4	1997	1102
G6DD	4	1997	1102
G6DE	4	1997	1102
G6DF	4	1997	1102
G6DG	4	1997	1102
G8DA	4	1560	1024
G8DB	4	1560	1024
G8DC	4	1560	1024
G8DD	4	1560	1024
G8DE	4	1560	1024
G8DF	4	1560	1024
GBVAJPF	4	2198	1126
GBVAJQJ	4	2198	1126
GBVAJQW	4	2198	1126
GBVAK	4	2488	1134
GL1	4	1117	998
GLA	4	1117	998
GLB	4	1117	998
GLC	4	1117	998
GLW	4	1117	998
GPDA	4	1560	1024
GPDB	4	1560	1024
GPDC	4	1560	1024
GSE	4	1117	998
GSF	4	1117	998
GSG	4	1117	998
GSH	4	1117	998

FORD

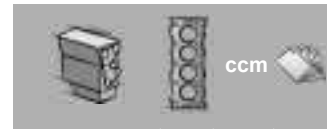
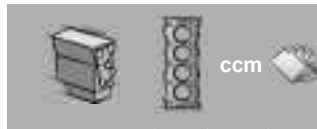

GUB	4	1117	1000
GUC	4	1117	1000
GUD	4	1117	1000
GUE	4	1117	1000
GUF	4	1117	1000
GZ	4	2261	1128
GZFA	4	2261	1128
GZFB	4	2261	1128
GZFC	4	2261	1128
H9FA	4	2402	1132
H9FB	4	2402	1132
H9FD	4	2402	1132
HCPA	4	1753	1054
HCPB	4	1753	1054
HCPC	4	1753	1054
HCPD	4	1753	1054
HHDA	4	1560	1024
HHDB	4	1560	1024
HHJA	4	1560	1024
HHJB	4	1560	1024
HHJC	4	1560	1024
HHJD	4	1560	1024
HHJE	4	1560	1024
HHJF	4	1560	1024
HJBA	4	1998	1108
HJBB	4	1998	1108
HJBC	4	1998	1108
HMDA	4	1988	1092
HUBA	5	2521	1144
HUWA	5	2521	1144
HWDA	4	1596	1032
HWDB	4	1596	1032
HXDA	4	1596	1028
HXDB	4	1596	1028
HXJA	4	1596	1034
HXJB	4	1596	1034
HXJD	4	1596	1034

HXJE	4	1596	1034
HYDA	5	2521	1144
HYDB	5	2521	1144
HYDC	5	2521	1144
IQDA	4	1596	1034
IQDB	4	1596	1034
IQJB	4	1596	1034
IQJC	4	1596	1034
IQJE	4	1596	1034
J4B	4	1299	1008
J4C	4	1299	1006
J4D	4	1299	1006
J4J	4	1299	1006
J4K	4	1299	1006
J4L	4	1299	1006
J4M	4	1299	1006
J4N	4	1299	1006
J4P	4	1299	1006
J4Q	4	1299	1006
J4R	4	1299	1006
J4S	4	1299	1006
J4T	4	1299	1006
J6A	4	1299	1008
J6B	4	1299	1008
JBA	4	1299	1006
JBB	4	1299	1006
JBC	4	1299	1008
JBD	4	1299	1006
JBE	4	1299	1008
JJA	4	1299	1006
JJB	4	1299	1006
JJC	4	1299	1006
JJD	4	1299	1006
JJE	4	1299	1006
JJF	4	1299	1006
JJG	4	1299	1006
JJH	4	1299	1006

JJJ	4	1299	1006
JJK	4	1299	1006
JJL	4	1299	1006
JJM	4	1299	1006
JKKC	4	1299	1006
JLA	4	1299	1006
JLB	4	1299	1006
JPA	4	1296	1004
JPC	4	1296	1004
JQDA	4	1596	1032
JQDB	4	1596	1032
JQGA	4	1596	1032
JQMA	4	1596	1032
JQMB	4	1596	1032
JTBA	4	1596	1032
JTBB	4	1596	1032
JTDA	4	1596	1032
JTDB	4	1596	1032
JTJA	4	1596	1032
JTJB	4	1596	1032
JTJC	4	1596	1032
JTMA	4	1596	1032
JTWA	4	1596	1032
JTWB	4	1596	1032
JXFA	4	2402	1132
JXFC	4	2402	1132
JZDA	5	2521	1144
KGBA	4	1596	1034
KHBA	4	1753	1052
KKDA	4	1753	1052
KKDB	4	1753	1052
KLBA	4	1997	1102
KNBA	4	2179	1120
KNBB	4	2179	1120
KNWA	4	2179	1120
KNWB	4	2179	1120
KVJA	4	1399	1016

L1E	4	1597	1038
L1F	4	1597	1036
L1G	4	1597	1038
L1H	4	1597	1038
L1J	4	1597	1036
L1K	4	1597	1038
L1L	4	1597	1038
L1N	4	1597	1038
L1Q	4	1597	1038
L1T	4	1596	1034
L1V	4	1596	1034
L1W	4	1596	1034
L4B	4	1597	1040
L6B	4	1597	1040
LAC	4	1593	1028
LAD	4	1593	1028
LAR	4	1593	1028
LCBA	6	2544	1144
LCBB	6	2495	1136
LCBC	6	2495	1136
LCBD	6	2495	1138
LCBE	6	2495	1136
LCE	4	1593	1028
LCJ	4	1593	1028
LE	4	1593	1028
LEC	4	1593	1028
LJA	4	1597	1040
LJB	4	1597	1040
LJC	4	1597	1040
LJD	4	1597	1040
LJE	4	1597	1040
LJF	4	1597	1040
LP1	4	1597	1042
LP2	4	1597	1042
LP3	4	1597	1042
LPA	4	1597	1042
LPBA	4	1997	1102

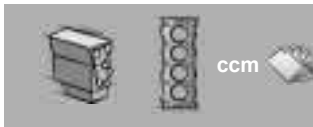

LR1	4	1597	1042
LR2	4	1597	1040
LRA	4	1597	1042
LRB	4	1597	1040
LSD	4	1597	1042
LSDA	4	1597	1042
LSE	4	1597	1042
LSF	4	1597	1042
LTA	4	1608	1044
LTB	4	1608	1044
LTC	4	1608	1044
LUA	4	1597	1042
LUAE	4	1597	1042
LUB	4	1597	1042
LUC	4	1597	1042
LUD	4	1597	1042
LUG	4	1597	1042
LUH	4	1597	1044
LUJ	4	1597	1044
LUK	4	1597	1044
M1CA	3	998	994
M1CB	3	998	994
M1DA	3	998	994
M1DC	3	998	994
M1DD	3	998	994
M1DH	3	998	994
M1JA	3	998	994
M1JC	3	998	994
M1JE	3	998	994
M1JH	3	998	994
M1JJ	3	998	994
M1JL	3	998	994
M1JM	3	998	994
M1JP	3	998	994
M1JU	3	998	994
M2DA	3	998	994
M2DB	3	998	994

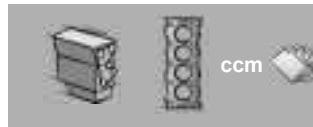

M2DC	3	998	994
M2GA	3	998	994
M2GB	3	998	994
M7JA	4	1242	1002
M7JB	4	1242	1002
M8DA	4	1498	1016
M8DB	4	1498	1016
M8DD	4	1498	1016
M8DE	4	1498	1016
M8DF	4	1498	1016
M8MA	4	1498	1016
M8MB	4	1498	1016
M8MC	4	1498	1016
M8MD	4	1498	1016
M8ME	4	1498	1016
M9DA	4	1498	1016
M9DB	4	1498	1016
M9DG	4	1498	1016
M9DH	4	1498	1016
M9MA	4	1498	1016
M9MB	4	1498	1016
M9MC	4	1498	1016
M9MD	4	1498	1016
M9ME	4	1498	1016
MEBA	6	2967	1150
MGDA	4	1999	1118
MTDA	4	1560	1024
MUDA	4	1596	1034
MUDD	4	1596	1034
N4A	4	1993	1098
N4B	4	1993	1098
N4I	4	1993	1098
N4JB	4	1999	1112
N6T	4	1993	1096
N6TS	4	1993	1096
N7BA	4	1998	1110
NAE	4	1993	1096



NAT	4	1993	1096
NAV	4	1993	1096
NAW	4	1993	1096
NAX	4	1993	1096
NBA	4	1993	1098
NCA	4	1993	1098
NE	4	1993	1096
NE1	4	1993	1096
NE3	4	1993	1096
NE4	4	1993	1096
NE5	4	1993	1096
NEE	4	1993	1096
NEG	4	1993	1096
NEJ	4	1993	1096
NEK	4	1993	1098
NEL	4	1993	1096
NEN	4	1993	1098
NEP	4	1993	1098
NER	4	1993	1096
NES	4	1993	1096
NET	4	1993	1098
NGA	4	1988	1094
NGB	4	1988	1094
NGC	4	1988	1094
NGCA	4	1560	1026
NGD	4	1988	1094
NGDA	4	1560	1026
NGDB	4	1560	1026
NR2	4	1993	1098
NRA	4	1993	1098
NRB	4	1993	1098
NRC	4	1993	1096
NRD	4	1993	1098
NRI	4	1993	1098
NSE	4	1998	1110
OHC LC	4	1993	1096
OHC TL 16 G	4	1593	1028

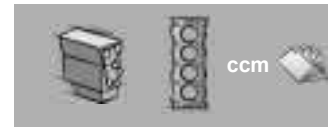

OHC TL 16 H	4	1593	1028
OHC TL 20	4	1993	1098
OHC TL 20 H	4	1993	1098
OHC TL 20 L	4	1993	1098
P0FA	4	1995	1100
P0FB	4	1995	1100
P4JA	3	998	996
P4JB	3	998	996
P4JC	3	998	996
P4JD	3	998	996
P5-AT	5	3198	1150
P7PA	4	1753	1054
P7PB	4	1753	1054
P8FA	4	2198	1124
P8FB	4	2198	1124
P9PA	4	1753	1054
P9PB	4	1753	1054
P9PC	4	1753	1054
P9PD	4	1753	1054
PD20FMCR	4	1998	1110
PGFA	4	2198	1124
PGFB	4	2198	1124
PHFA	4	2402	1132
PHFC	4	2402	1132
PNBA	4	1596	1034
PNDA	4	1596	1034
PNDD	4	1596	1034
PR	6	2792	1148
PR3	6	2792	1148
PR4	6	2792	1148
PR5	6	2792	1148
PR6	6	2792	1148
PR7	6	2792	1148
PR8	6	2792	1148
PRB	6	2792	1148
PRC	6	2792	1148
PRD	6	2792	1148

FORD

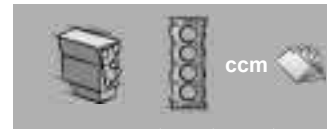
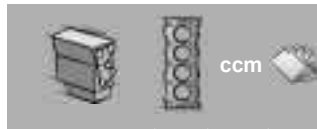

PRE	6	2792	1148
PRG	6	2792	1148
PRI	6	2792	1148
PRN	6	2792	1148
PRT	6	2792	1148
PYA	6	2792	1148
PYU	6	2792	1148
Q0JA	3	998	994
Q0JB	3	998	994
Q0JC	3	998	994
Q0JD	3	998	994
Q4BA	4	2179	1120
Q4WA	4	2179	1120
Q7DA	4	1798	1082
QJBA	4	2198	1122
QJBB	4	2198	1122
QJBC	4	2198	1122
QJBD	4	2198	1122
QQDA	4	1798	1082
QQDB	4	1798	1082
QQDC	4	1798	1082
QQDD	4	1798	1082
QVFA	4	2198	1124
QWFA	4	2198	1124
QXBA	4	1997	1102
QXBB	4	1997	1102
QXWA	4	1997	1102
QXWB	4	1997	1102
QXWC	4	1997	1102
QYBA	4	1753	1052
QYWA	4	1753	1052
R2A	4	1769	1076
R2C	4	1769	1076
R2PA	4	1753	1054
R3PA	4	1753	1054
R9CB	4	1999	1112
R9CD	4	1999	1112

R9CF	4	1999	1112
R9CH	4	1999	1112
R9CI	4	1999	1112
R9DA	4	1999	1112
R9DB	4	1999	1112
R9DC	4	1999	1112
R9DD	4	1999	1112
R9MA	4	1999	1114
R9MB	4	1999	1114
RDA	4	1796	1078
RDB	4	1796	1078
REBA	6	2967	1150
RFA	4	1753	1060
RFB	4	1753	1060
RFD	4	1753	1056
RFK	4	1753	1056
RFL	4	1753	1060
RFM	4	1753	1066
RFN	4	1753	1064
RFS	4	1753	1066
RHBA	4	1596	1034
RKA	4	1796	1080
RKB	4	1796	1080
RKC	4	1796	1078
RKF	4	1796	1080
RKH	4	1796	1080
RKJ	4	1796	1080
RKK	4	1796	1080
RQB	4	1796	1078
RQC	4	1796	1078
RTA	4	1753	1068
RTB	4	1753	1068
RTC	4	1753	1070
RTD	4	1753	1070
RTE	4	1753	1070
RTF	4	1753	1070
RTG	4	1753	1070

RTH	4	1753	1070
RTJ	4	1753	1074
RTJA	4	1388	1010
RTJB	4	1388	1010
RTJC	4	1388	1012
RTJD	4	1388	1012
RTK	4	1753	1074
RTN	4	1753	1076
RTP	4	1753	1076
RTQ	4	1753	1076
RVA	4	1753	1064
RWPA	4	1753	1054
RWPB	4	1753	1054
RWPC	4	1753	1054
RWPD	4	1753	1054
RWPE	4	1753	1054
RWPF	4	1753	1054
S7CB	4	2489	1136
S7GA	4	2488	1134
S7GB	4	2488	1134
SA2R	5	3198	1150
SA2S	5	3198	1150
SA2W	5	3198	1150
SAFA	5	3198	1152
SAFB	5	3198	1152
SCB	4	2500	1142
SCC	4	2500	1144
SDBA	4	1998	1106
SEA	6	2544	1144
SEB	6	2495	1136
SEBA	4	2261	1128
SEC	6	2495	1136
SEWA	4	2261	1128
SFA	4	2498	1140
SFB	4	2498	1140
SFCA	3	998	994
SFCB	3	998	994

SFCC	3	998	994
SFCD	3	998	994
SFCE	3	998	994
SFCF	3	998	994
SFDA	3	998	994
SFDB	3	998	994
SFDC	3	998	994
SFJA	3	998	994
SFJB	3	998	994
SFJC	3	998	994
SFJD	3	998	994
SFJE	3	998	994
SFJF	3	998	994
SFJH	3	998	994
SFJJ	3	998	994
SFJK	3	998	994
SFJL	3	998	994
SFJN	3	998	994
SFJP	3	998	994
SGA	6	2495	1136
SHDA	4	1596	1032
SHDB	4	1596	1032
SHDC	4	1596	1032
SIDA	4	1596	1028
SNJA	4	1242	1002
SNJB	4	1242	1002
SNJC	4	1242	1002
SNJD	4	1242	1002
SPJA	4	1388	1010
SPJC	4	1388	1010
SPJD	4	1388	1012
SPJE	4	1388	1012
SRFA	4	2198	1124
SRFB	4	2198	1124
SRFC	4	2198	1124
SRFD	4	2198	1124
SRFE	4	2198	1124



STJA	4	1242	1002
STJB	4	1242	1002
STJC	4	1242	1002
STP	4	2498	1140
STR	4	2498	1142
SWFA	4	2402	1132
SYDA	4	1999	1112
T1BA	4	1560	1026
T1BB	4	1560	1026
T1BC	4	1560	1026
T1DA	4	1560	1026
T1DB	4	1560	1026
T1GA	4	1560	1026
T1WA	4	1560	1026
T1WB	4	1560	1026
T22DD0P	4	2198	1126
T3CA	4	1560	1026
T3CB	4	1560	1026
T3CC	4	1560	1026
T3DA	4	1560	1026
T3DB	4	1560	1026
T3JA	4	1560	1026
T3JB	4	1560	1026
T7CA	4	1997	1104
T7CC	4	1997	1104
T7CD	4	1997	1104
T7CE	4	1997	1104
T7CF	4	1997	1104
T7CI	4	1997	1104
T7CJ	4	1997	1104
T7CK	4	1997	1104
T7CL	4	1997	1104
T7CN	4	1997	1104
T7CP	4	1997	1104
T7CQ	4	1997	1104
T7DA	4	1997	1104
T7DB	4	1997	1104



T7DC	4	1997	1104
T7DD	4	1997	1104
T7MA	4	1997	1104
T7MB	4	1997	1104
T7MC	4	1997	1104
T7MD	4	1997	1104
T8CA	4	1997	1104
T8CB	4	1997	1104
T8CC	4	1997	1104
T8CD	4	1997	1104
T8CG	4	1997	1104
T8CH	4	1997	1104
T8CI	4	1997	1104
T8CJ	4	1997	1104
T8CL	4	1997	1104
T8DA	4	1997	1104
T8DE	4	1997	1104
T8MA	4	1997	1104
T8MB	4	1997	1104
T8MC	4	1997	1104
T9CA	4	1997	1104
T9CB	4	1997	1104
T9CC	4	1997	1104
T9CD	4	1997	1104
TBBA	4	1999	1112
TBBB	4	1999	1112
TBWA	4	1999	1112
TBWB	4	1999	1112
TKA	4	957	994
TKB	4	957	994
TKW	4	957	994
TL 16M	4	1593	1028
TL 20 LC	4	1993	1096
TL20LNM	4	1993	1098
TLA	4	957	994
TLB	4	999	996
TNBA	4	1999	1114



TNBB	4	1999	1114
TNCA	4	1999	1116
TNCB	4	1999	1116
TNCC	4	1999	1116
TNCD	4	1999	1116
TNCF	4	1999	1116
TNWA	4	1999	1116
TNWB	4	1999	1116
TPBA	4	1999	1114
TPWA	4	1999	1116
TXBA	4	1997	1104
TXBB	4	1997	1104
TXDA	4	1997	1104
TXDB	4	1997	1104
TXMA	4	1997	1104
TXWA	4	1997	1104
TYBA	4	1997	1104
TYDA	4	1997	1104
TYMA	4	1997	1104
TYWA	4	1997	1104
TZGA	4	1560	1026
TZGB	4	1560	1026
TZJA	4	1560	1026
TZJB	4	1560	1026
U3CA	4	1560	1026
U5JA	4	1596	1034
UACA	4	1999	1118
UACC	4	1999	1118
UADA	4	1999	1118
UBGA	4	1560	1026
UBJA	4	1560	1024
UEJB	4	1499	1018
UFBA	4	1997	1104
UFBB	4	1997	1104
UFCA	4	1997	1104
UFCD	4	1997	1104



UFDA	4	1997	1104
UFDB	4	1997	1104
UFMA	4	1997	1104
UFWA	4	1997	1104
UGCA	4	1499	1020
UGCB	4	1499	1020
UGCC	4	1499	1020
UGJC	4	1499	1020
UGJE	4	1499	1020
UGJG	4	1499	1020
UGJM	4	1499	1020
UHFA	4	2198	1124
UHFB	4	2198	1124
UHFC	4	2198	1124
UHR5	4	2198	1126
UKBA	4	1997	1104
UKBB	4	1997	1104
UKDA	4	1997	1104
UKDB	4	1997	1104
UKMA	4	1997	1104
UKWA	4	1997	1104
UNCA	4	1498	1016
UNCB	4	1498	1016
UNCC	4	1498	1016
UNCD	4	1498	1016
UNCE	4	1498	1016
UNCF	4	1498	1016
UNCG	4	1498	1016
UNCH	4	1498	1016
UNCI	4	1498	1016
UNCJ	4	1498	1016
UNCJ	4	1498	1016
UNCK	4	1498	1016
UNCM	4	1498	1016
UNCN	4	1498	1016
UNCP	4	1498	1016
USF6	4	2198	1126
USR6	4	2198	1126

FORD



FORD

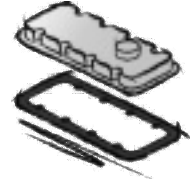
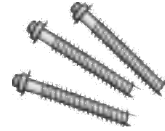
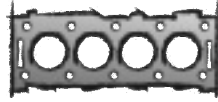
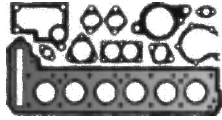

TKA **TKB**
TKW **TLA**

4 Cyl. **957 ccm**
Cyl. 74,0 Ø

Fiesta
05/1976 → 11/1989

ES⊕ **751.066 ●**
93BX 6014AA
5 028 400
+86BM 6051B1B
+5 026 593

561.951 ●
86BM 6051B2B
5 026 593

80 Ø

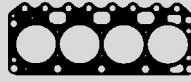

087.262
96BM 6584A1A
1 000 438



B3GA **B3GB**
M1CA **M1CB**
M1DA **M1DC**
M1DD **M1DH**
M1JA **M1JC**
M1JE **M1JH**
M1JJ **M1JL**
M1JM **M1JP**
M1JU **M2DA**
M2DB **M2DC**
M2GA **M2GB**
Q0JA **Q0JB**
Q0JC **Q0JD**
SFCA **SFCB**
SFCC **SFCD**
SFCE **SFCF**
SFDA **SFDB**
SFDC **SFJA**
SFJB **SFJC**
SFJD **SFJE**
SFJF **SFJH**
SFJJ **SFJK**
SFJL **SFJN**
SFJP **YYJA**
YYJB **YYJC**
YYJD **YYJE**
YYJF **YYJG**

3 Cyl. **998 ccm**
Cyl. 71,9 Ø

B-Max
08/2012 →
C-Max
10/2012 → 06/2019
Ecosport
10/2013 →
Fiesta
09/2012 →
Focus
02/2012 →
Grand C-Max
10/2012 → 06/2019
Mondeo
02/2015 →
Tourneo Connect
11/2013 →
Tourneo Courier
02/2014 →
Transit Connect
02/2013 →
Transit Courier
02/2014 →

ES⊕ **657.110**
ES⊕ **713.110**
CS* **773.130**













650.420
CM5G 6051GC
1 939 521
0,70 mm ± 73 Ø









ZKS 477.970
CM5G-6065-EA (8x)
1 804 813 (8x)

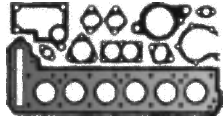
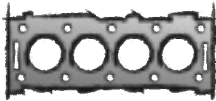

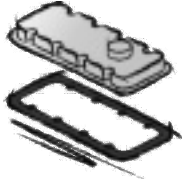
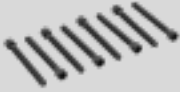



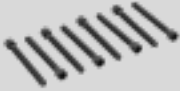
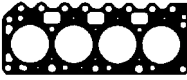







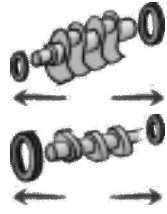





696.080
CM5G-6K260-EB
1 799 829



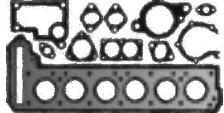
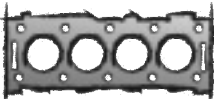

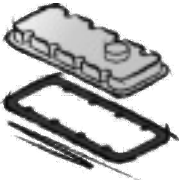
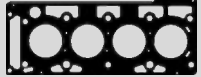



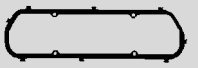



















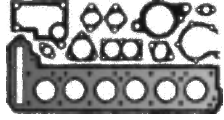
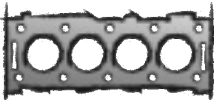



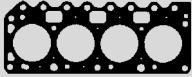

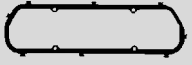

			<p>a) </p> <p>b) </p>	<p>K: </p> <p>N: </p>	
<p>206.954 70HM 6571A3B 1 490 525 ACM E 4x</p> 	<p>103.706 77BM 9448EB 5 026 592 4x</p> 	<p>102.823 77BM 9441DB 5 026 591</p> 	<p>a) 103.960 A76SX 6013A1A 6 707 924</p>  <p>b) 786.500 928M 6734AA 1 454 118 Nylon A 14,5x22x2</p>	<p>K:← 586.730 83BM 6700A4A 6 139 049 ASW RD VMQ 36,51x52,48x8</p> <p>K:→ 693.201 92TM 6701A1A 1 048 572 ASW LD FPM 60,45x76,18x10</p>	
<p>317.020 BM5G-6571-CA 1 791 865 FPM 12x</p>	<p>AAS 553.480</p>	<p>AAS 770.330</p> 	<p>a) 036.164 Dirko HT / EU</p> <p>a) 510.031 Dirko HT / USA/CDN/MEX</p> <p>a) 527.291 Dirko HT / RU</p> <p>a) 648.661 Dirko HT / BR</p> <p>b) 012.001 97JM 6730BA 1 013 938 M 14x1,5x20</p> <p>b) 176.090 97JM 6734BA 1 005 593 13x22,4x3</p>	<p>K:← 707.450 CM5G-6700-EB 1 812 510 ASW OF RD FPM 55x70x8</p> <p>K:→ 765.860 CM5G-6K301-EB 1 828 787 SP LD AEM 80</p>	<p>TLS 657.120</p>



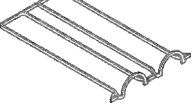

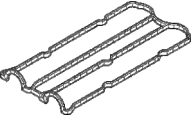

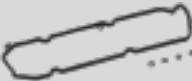











<p>FORD</p> 				
<p> P4JA P4JB P4JC P4JD XMJA XMJB XMJC XMJD </p> <p>3 Cyl. 998 ccm Cyl. 71,9 Ø</p> <p>Fiesta 10/2012 →</p> <p>Ka 08/2014 → 12/2018</p>	<p> ES⊕ 657.110 ES⊕ 713.110 CS* 773.130 </p>	<p> 650.420 CM5G 6051GC 1 939 521 0,70 mm $\frac{1}{16}$ 73 Ø </p>	<p> ZKS 477.970 CM5G-6065-EA (8x) 1 804 813 (8x) </p> 	<p> 696.080 CM5G-6K260-EB 1 799 829 </p> 
<p>B3DA</p> <p>3 Cyl. 999 ccm Cyl. 71,9 Ø</p> <p>C-Max 07/2018 → 06/2019</p> <p>Focus 01/2018 →</p> <p>Grand C-Max 10/2012 → 06/2019</p>	<p> ES⊕ 657.110 ES⊕ 713.110 CS* 773.130 </p>	<p> 650.420 CM5G 6051GC 1 939 521 0,70 mm $\frac{1}{16}$ 73 Ø </p>	<p> ZKS 477.970 CM5G-6065-EA (8x) 1 804 813 (8x) </p> 	<p> 696.080 CM5G-6K260-EB 1 799 829 </p> 
<p>B7JG</p> <p>3 Cyl. 999 ccm Cyl. 71,9 Ø</p> <p>Puma 12/2021 →</p>	<p>CS* 773.130</p>		<p> ZKS 477.970 CM5G-6065-EA (8x) 1 804 813 (8x) </p> 	
<p>TLB</p> <p>4 Cyl. 999 ccm Cyl. 68,7 Ø</p> <p>Fiesta 03/1989 → 12/1995</p>	<p> S⊕* 766.675 ● ES⊕ 766.682 93BX 6014AA 5 028 399 +89BM 6051B2D +1 020 808 </p>	<p> 693.553 89BM 6051B2D 1 020 808 1,00 mm $\frac{1}{16}$ 70,2 Ø </p> 	<p> ZKS 802.910 6 184 406 (10x) M 11x1,5x121 </p> 	<p> 087.262 96BM 6584A1A 1 000 438 </p> 











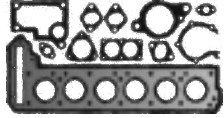
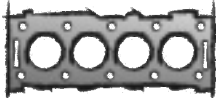

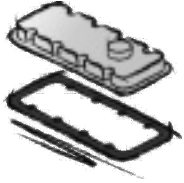



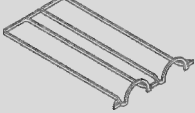

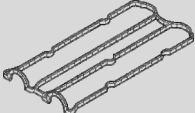
			<p>a) </p> <p>b) </p>	<p>K: </p> <p>N: </p>	
<p>317.020 BM5G-6571-CA 1 791 865 FPM 12x</p>	<p>AAS 553.480</p>	<p>AAS 770.330</p> 	<p>a) 036.164 Dirko HT / EU</p> <p>a) 510.031 Dirko HT / USA/CDN/MEX</p> <p>a) 527.291 Dirko HT / RU</p> <p>a) 648.661 Dirko HT / BR</p> <p>b) 012.001 97JM 6730BA 1 013 938 M 14x1,5x20</p> <p>b) 176.090 97JM 6734BA 1 005 593 13x22,4x3</p>	<p>K:← 707.450 CM5G-6700-EB 1 812 510 ASW OF RD FPM 55x70x8</p> <p>K:→ 765.860 CM5G-6K301-EB 1 828 787 SP LD AEM 80</p>	
<p>317.020 BM5G-6571-CA 1 791 865 FPM 12x</p>	<p>AAS 553.480</p>	<p>AAS 770.330</p> 	<p>a) 036.164 Dirko HT / EU</p> <p>a) 510.031 Dirko HT / USA/CDN/MEX</p> <p>a) 527.291 Dirko HT / RU</p> <p>a) 648.661 Dirko HT / BR</p> <p>b) 012.001 97JM 6730BA 1 013 938 M 14x1,5x20</p> <p>b) 176.090 97JM 6734BA 1 005 593 13x22,4x3</p>	<p>K:← 707.450 CM5G-6700-EB 1 812 510 ASW OF RD FPM 55x70x8</p> <p>K:→ 765.860 CM5G-6K301-EB 1 828 787 SP LD AEM 80</p>	<p>TLS 657.120</p>
<p>317.020 BM5G-6571-CA 1 791 865 FPM 12x</p>			<p>a) 036.164 Dirko HT / EU</p> <p>a) 510.031 Dirko HT / USA/CDN/MEX</p> <p>a) 527.291 Dirko HT / RU</p> <p>a) 648.661 Dirko HT / BR</p> <p>b) 012.001 97JM 6730BA 1 013 938 M 14x1,5x20</p> <p>b) 176.090 97JM 6734BA 1 005 593 13x22,4x3</p>	<p>K:← 707.450 CM5G-6700-EB 1 812 510 ASW OF RD FPM 55x70x8</p>	
<p>766.615 88WM 6571A2A 6 166 533 FPM 8x</p>	<p>916.295 95BM 9448AC 7 126 483 4x</p> 	<p>765.112 89BM 9441AB 6 173 339</p> 	<p>a) 103.960 A76SX 6013A1A 6 707 924</p>  <p>b) 786.500 928M 6734AA 1 454 118 Nylon A 14,5x22x2</p>	<p>K:← 586.730 83BM 6700A4A 6 139 049 ASW RD VMQ 36,51x52,48x8</p> <p>K:→ 693.201 92TM 6701A1A 1 048 572 ASW LD FPM 60,45x76,18x10</p>	



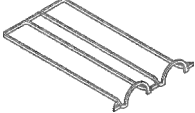

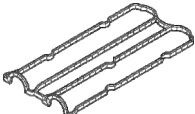



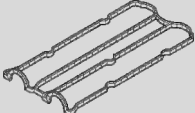





<p>FORD</p> 				
<p>C4E CPJA ZH10JRB/JRY</p> <p>4 Cyl. 999 ccm Cyl. 68,7 Ø</p> <p>Fiesta 04/1996 →</p> <p>Ka 01/1997 → 11/2008</p>	<p>CS* 030.440</p>	<p>383.230 ● XS6E 6051AC 1 089 763 0,40 mm ± 70 Ø</p> 	<p>ZKS 156.550 1 385 727 (10x) M 11x1,5x158</p> 	<p>026.540 XS6E 6584AB 1 089 844</p> 
<p>FSJB XPJA XPJB XPJC XPJD XYJA XYJB XYJC XYJD XYJE XYJF</p> <p>3 Cyl. 1084 ccm Cyl. 73,0 Ø</p> <p>Fiesta 05/2017 →</p>			<p>ZKS 477.970 CM5G-6065-EA (8x) 1 804 813 (8x)</p> 	
<p>GL1 GLA GLB GLC GLW GSE GSF GSG GSH</p> <p>4 Cyl. 1117 ccm Cyl. 74,0 Ø</p> <p>Escort 09/1980 → 09/1990</p> <p>Fiesta 05/1976 → 02/1989</p>	<p>ES⊕ 751.066 ● 93BX 6014AA 5 028 400 +86BM 6051B1B +5 026 593</p>	<p>561.951 ● 86BM 6051B2B 5 026 593 80 Ø</p> 		<p>087.262 96BM 6584A1A 1 000 438</p> 

			<p>a) </p> <p>b) </p>	<p>K: </p> <p>N: </p>	
<p>026.640 XS6E 6571AB 1 313 567 FPM 8x</p>		<p>025.271 2S6U 9441AA 1 149 707 2x</p> 	<p>a) 025.481 XS6E 6710A2B 1 089 838</p>  <p>b) 012.001 97JM 6730BA 1 013 938 M 14x1,5x20</p> <p>b) 176.090 97JM 6734BA 1 005 593 13x22,4x3</p>	<p>K:← 023.740 2S6G 6D316AA 1 219 337 ASW RD PTFE/ACM 40x62x7,4</p> <p>K:→ 023.950 2S6G 6A321BA 1 388 409 IWD LD PTFE 79,33x131,3x19</p>	
<p>317.020 BM5G-6571-CA 1 791 865 FPM 12x</p>	<p>547.920 1 805 818</p> 		<p>a) 036.164 Dirko HT / EU</p> <p>a) 510.031 Dirko HT / USA/CDN/MEX</p> <p>a) 527.291 Dirko HT / RU</p> <p>a) 648.661 Dirko HT / BR</p> <p>b) 012.001 97JM 6730BA 1 013 938 M 14x1,5x20</p> <p>b) 176.090 97JM 6734BA 1 005 593 13x22,4x3</p>	<p>K:← 707.450 CM5G-6700-EB 1 812 510 ASW OF RD FPM 55x70x8</p> <p>K:→ 765.860 CM5G-6K301-EB 1 828 787 SP LD AEM 80</p>	
<p>206.954 70HM 6571A3B 1 490 525 ACM E 4x</p> 	<p>103.706 77BM 9448EB 5 026 592 4x</p> 	<p>102.823 77BM 9441DB 5 026 591</p> 	<p>a) 103.960 A76SX 6013A1A 6 707 924</p>  <p>b) 786.500 928M 6734AA 1 454 118 Nylon A 14,5x22x2</p>	<p>K:← 586.730 83BM 6700A4A 6 139 049 ASW RD VMQ 36,51x52,48x8</p> <p>K:→ 693.201 92TM 6701A1A 1 048 572 ASW LD FPM 60,45x76,18x10</p>	

FORD 					
G6A GUB GUC GUD GUE GUF 4 Cyl. 1117 ccm Cyl. 68,7 Ø Fiesta 03/1989 → 12/1995	S⊕* 766.675 ● →04/1992 ES⊕ 766.682 93BX 6014AA 5 028 399 +89BM 6051B2D +1 020 808 CS* 424.560 93BX 6013BA 5 028 398 04/1992→  FE	693.553 89BM 6051B2D 1 020 808 1,00 mm $\frac{1}{2}$ 70,2 Ø 	ZKS 802.910 6 184 406 (10x) M 11x1,5x121 	087.262 96BM 6584A1A 1 000 438 	
DHA DHB DHC DHD DHE DHF DHG 4 Cyl. 1242 ccm Cyl. 71,9 Ø Fiesta 08/1995 → 01/2002	ES⊕ 023.551 96MX 6014AA 1 015 369   CS* 023.660 96MX 6013AA 1 015 368 →11/1999	025.040 96MM 6051BC 1 035 729 1,25 mm $\frac{1}{2}$ 73 Ø →05/1998 025.030 YS6G 6051BA 1 100 328 0,50 mm $\frac{1}{2}$ 73 Ø 05/1998→  	ZKS 087.830 1 765 604 (10x) M 10x1,5x143 	389.110  AL  761.031 1S6G 6K260AA 1 141 575  PLASTIC 	
169A4000 AAAA FP4 4 Cyl. 1242 ccm Cyl. 70,8 Ø Ka 10/2008 → 05/2016	ES⊕ 037.461 CS* 431.560	040.554 1 535 632 0,49 mm $\frac{1}{2}$ 72,4 Ø 	ZKS 760.720 1 549 981 (10x) M 9x1,25x96 	ZKHS 724.280  505.060 1 563 478 	

			<p>a) </p> <p>b) </p>	<p>K: </p> <p>N: </p>	
<p>766.615 88WM 6571A2A 6 166 533 FPM 8x</p>	<p>916.295 95BM 9448AC 7 126 483 4x</p> 	<p>765.112 89BM 9441AB 6 173 339</p> 	<p>a) OWS 751.040 96BX 6013CA 1 016 152 04/1992→</p>  <p>FE</p>  <p>a) 103.960 A76SX 6013A1A 6 707 924 →04/1992</p>  <p>b) 786.500 928M 6734AA 1 454 118 Nylon A 14,5x22x2</p>	<p>K:← 586.730 83BM 6700A4A 6 139 049 ASW RD VMQ 36,51x52,48x8</p> <p>K:→ 693.201 92TM 6701A1A 1 048 572 ASW LD FPM 60,45x76,18x10 →04/1992</p> <p>K:→ 550.680 1 032 209 ASW LD PTFE/FPM 79,33x95,28x11 04/1992→</p> <p>K:→ 763.713 86HM 6701A1A 1 641 893 AW/BS LD FPM 79,33x95,25x11 04/1992→</p>	
<p>VAS 398.450 026.700 96MM 6571AG 1 148 124 FPM E 8x</p> <p>026.670 96MM 6571BG 1 148 123 FPM A 8x</p>	<p>864.221 98MM 9448AB 1 072 066</p> 	<p>025.280 96MM 9441AD 1 004 476 2x →11/1999</p> <p>025.290 YS6U 9441AB 1 130 257 12/1999→ 4x</p> 	<p>a) 025.450 96MM 6710AD 1 004 459 →11/1999</p>  <p>a) 036.164 Dirko HT / EU 12/1999→</p> <p>a) 510.031 Dirko HT / USA/CDN/MEX 12/1999→</p> <p>a) 527.291 Dirko HT / RU 12/1999→</p> <p>a) 648.661 Dirko HT / BR 12/1999→</p> <p>b) 012.001 97JM 6730BA 1 013 938 M 14x1,5x20</p> <p>b) 176.090 97JM 6734BA 1 005 593 13x22,4x3</p>	<p>K:← 023.590 YS6G 6700AA 1 112 945 ASW RD FPM 33x47x5</p> <p>K:→ 023.862 1S4G-6K301AB 1 211 161 SP LD PTFE 80</p> <p>N:← 023.520 6M5G 6K292BA 1 471 482 ASW RD FPM 38x52x6 2x</p>	
<p>VAS 688.050 FPM</p> <p>476.691 1 535 535 FPM 8x</p>	<p>375.070 1 560 743</p> 	<p>AAS 444.760 1 580 144</p> 	<p>a) 036.164 Dirko HT / EU</p> <p>a) 510.031 Dirko HT / USA/CDN/MEX</p> <p>a) 527.291 Dirko HT / RU</p> <p>a) 648.661 Dirko HT / BR</p> <p>b) 587.100 M 22x1,5x13</p>	<p>K:← 069.540 1 535 494 AW/BS RD FPM 27x37x7</p> <p>K:→ 069.600 1 565 564 AW/BS LD FPM 74x88x8</p> <p>N:← 290.710 1 535 463 AW/BS RD FPM 40x55x7</p>	

FORD 					
FUJA FUJB 4 Cyl. 1242 ccm Cyl. 71,9 Ø Fiesta 05/2002 → 06/2008 Fusion 08/2004 → 12/2012	ES⊕ 024.961   CS* 025.510	025.030 YS6G 6051BA 1 100 328 0,50 mm $\frac{\pm}{\text{mm}}$ 73 Ø →12/2002 125.022 3S4G 6051BA 1 229 474 0,32 mm $\frac{\pm}{\text{mm}}$ 73 Ø 12/2002→	ZKS 087.830 1 765 604 (10x) M 10x1,5x143 	389.110  AL  761.031 1S6G 6K260AA 1 141 575 PLASTIC  	
M7JA M7JB 4 Cyl. 1242 ccm Cyl. 71,9 Ø Fiesta 03/2003 → 06/2008	ES⊕ 024.961   CS* 025.510	125.022 3S4G 6051BA 1 229 474 0,32 mm $\frac{\pm}{\text{mm}}$ 73 Ø	ZKS 087.830 1 765 604 (10x) M 10x1,5x143 	389.110  AL  761.031 1S6G 6K260AA 1 141 575 PLASTIC  	
SNJA SNJB SNJC SNJD STJA STJB STJC 4 Cyl. 1242 ccm Cyl. 71,9 Ø Fiesta 06/2008 →	ES⊕ 790.620 CS* 752.860 	457.531 8A6G 6051BB 1 538 349 0,30 mm $\frac{\pm}{\text{mm}}$ 72,9 Ø	ZKS 087.830 1 765 604 (10x) M 10x1,5x143 	761.031 1S6G 6K260AA 1 141 575 PLASTIC  	

			<p>a) </p> <p>b) </p>	<p>K: </p> <p>N: </p>	
<p>VAS 398.450 026.700 96MM 6571AG 1 148 124 FPM E 8x</p> <p>026.670 96MM 6571BG 1 148 123 FPM A 8x</p>	<p>024.940 97MF 9448AA 1 031 021</p> 	<p>025.260 2S6G 9441CA 1 142 502 4x</p> 	<p>a) 036.164 Dirko HT / EU</p> <p>a) 510.031 Dirko HT / USA/CDN/MEX</p> <p>a) 527.291 Dirko HT / RU</p> <p>a) 648.661 Dirko HT / BR</p> <p>b) 012.001 97JM 6730BA 1 013 938 M 14x1,5x20</p> <p>b) 176.090 97JM 6734BA 1 005 593 13x22,4x3</p>	<p>K:← 023.590 YS6G 6700AA 1 112 945 ASW RD FPM 33x47x5</p> <p>K:→ 023.862 1S4G-6K301AB 1 211 161 SP LD PTFE 80</p> <p>N:← 023.520 6M5G 6K292BA 1 471 482 ASW RD FPM 38x52x6 2x</p>	
<p>VAS 398.450 026.700 96MM 6571AG 1 148 124 FPM E 8x</p> <p>026.670 96MM 6571BG 1 148 123 FPM A 8x</p>	<p>024.940 97MF 9448AA 1 031 021</p> 	<p>025.260 2S6G 9441CA 1 142 502 4x</p> 	<p>a) 036.164 Dirko HT / EU</p> <p>a) 510.031 Dirko HT / USA/CDN/MEX</p> <p>a) 527.291 Dirko HT / RU</p> <p>a) 648.661 Dirko HT / BR</p> <p>b) 012.001 97JM 6730BA 1 013 938 M 14x1,5x20</p> <p>b) 176.090 97JM 6734BA 1 005 593 13x22,4x3</p>	<p>K:← 023.590 YS6G 6700AA 1 112 945 ASW RD FPM 33x47x5</p> <p>K:→ 023.862 1S4G-6K301AB 1 211 161 SP LD PTFE 80</p> <p>N:← 023.520 6M5G 6K292BA 1 471 482 ASW RD FPM 38x52x6 2x</p>	
<p>VAS 398.450 026.700 96MM 6571AG 1 148 124 FPM E 8x</p> <p>026.670 96MM 6571BG 1 148 123 FPM A 8x</p>	<p>377.811 2S6G 9448DA 1 326 381</p> 	<p>753.020 1 538 577 4x</p> 	<p>a) 036.164 Dirko HT / EU</p> <p>a) 510.031 Dirko HT / USA/CDN/MEX</p> <p>a) 527.291 Dirko HT / RU</p> <p>a) 648.661 Dirko HT / BR</p> <p>b) 012.001 97JM 6730BA 1 013 938 M 14x1,5x20</p> <p>b) 176.090 97JM 6734BA 1 005 593 13x22,4x3</p>	<p>K:← 023.590 YS6G 6700AA 1 112 945 ASW RD FPM 33x47x5</p> <p>K:→ 023.862 1S4G-6K301AB 1 211 161 SP LD PTFE 80</p> <p>N:← 023.520 6M5G 6K292BA 1 471 482 ASW RD FPM 38x52x6 2x</p>	

FORD

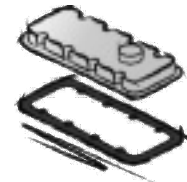
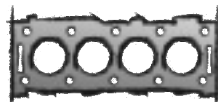
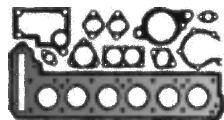

169A1000 BAAA
FD4

4 Cyl. **1248 ccm**
Cyl. 69,6 Ø

Ka TDCi
10/2008 → 05/2016

ES⊕ **431.401**



CS* **452.150**

076.348



0,028 mm
→
0,127 mm



0,72 mm $\frac{+}{-}$ 70,6 Ø

076.358



0,128 mm
→
0,227 mm



0,82 mm $\frac{+}{-}$ 70,6 Ø

1 ⊗

076.408



0,228 mm
→
0,327 mm

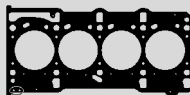

0,92 mm $\frac{+}{-}$ 70,6 Ø

2 ⊗

ZKS 374.240

1 562 728 (10x)
M 10x1,25x119

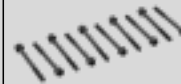

074.173

1 563 470

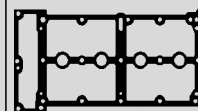

JPA JPC

4 Cyl. **1296 ccm**
Cyl. 80,0 Ø

Escort
09/1980 → 07/1988

Fiesta
09/1983 → 09/1989

Orion
07/1983 → 07/1988

ES⊕ **325.121**

93SX 6014BA
1 008 718
+86SM 6051A3C
+6 772 502

CS* **762.874**

93SX 6013BA
5 028 484
04/1985→

814.262

92SM 6051BA

6 772 502

1,70 mm $\frac{+}{-}$ 83 Ø



ZKS 820.490

6 088 344 (10x)
M 10x1,5x135



764.221

88SM 6584AA
1 651 775

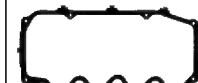

A9A A9JA A9JD BAJA

A9B A9JB BAA

4 Cyl. **1299 ccm**
Cyl. 74,0 Ø

Fiesta
11/2001 → 08/2008

Fusion
11/2002 → 07/2005

Ka
09/1996 → 11/2008

ES⊕ **026.910**

CS* **030.440**

025.000

1N2G 6051B2D

1 351 483

0,35 mm $\frac{+}{-}$ 76 Ø



ZKS 156.550

















1 385 727 (10x)
M 11x1,5x158

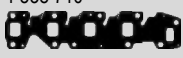
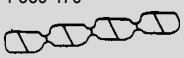

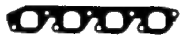



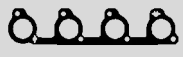



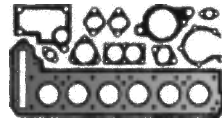
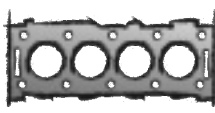

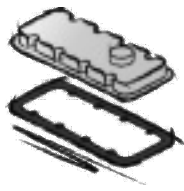

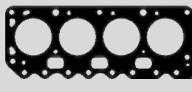

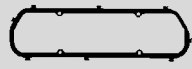

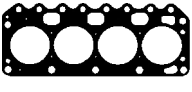

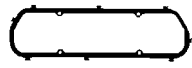







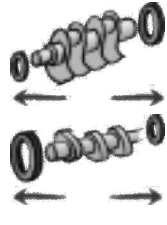





026.540











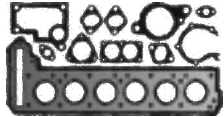
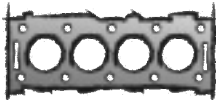

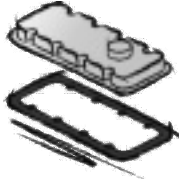





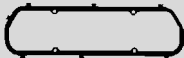



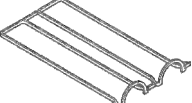

XS6E 6584AB
1 089 844

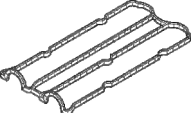





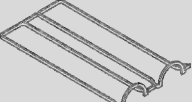

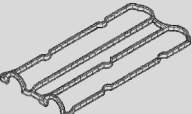











			<p>a) </p> <p>b) </p>	<p>K: </p> <p>N: </p>	
<p>VAS 445.100 FPM</p>	<p>431.310 1 538 710</p> 	<p>431.180 1 539 476</p> 	<p>a) 036.164 Dirko HT / EU</p> <p>a) 510.031 Dirko HT / USA/CDN/MEX</p> <p>a) 527.291 Dirko HT / RU</p> <p>a) 648.661 Dirko HT / BR</p> <p>b) 587.100 M 22x1,5x13</p>	<p>K:← 445.060 1 538 743 AW/BS RD FPM 40x52x7</p> <p>K:→ 428.970 1 550 335 ASW LD PTFE/ACM 78x100x9</p>	<p>TLS 715.320</p> 
<p>405.990 81SM 6571A2F 6 674 302 FPM 8x</p>	<p>318.974 91SM 9448BB 6 591 017</p> 	<p>318.968 92SM 9441AA 6 851 355</p> 	<p>a) OWS 388.940 6 166 108 +1 454 118 04/1985→</p>  <p>a) 587.486 88SM 6710AA 6 166 108 04/1985→</p>  <p>b) 786.500 928M 6734AA 1 454 118 Nylon A 14,5x22x2</p>	<p>K:← 757.292 928M 6700B5A 6 165 500 ASW RD FPM 35x50x7</p> <p>K:→ 750.476 928M 6701B5A 6 126 179 ASW LD FPM 88x108x11</p> <p>N:← 757.497 86HM 6700AA 1 669 254 ASW RD FPM 42x56x7</p>	
<p>026.640 XS6E 6571AB 1 313 567 FPM 8x</p>	<p>024.950 1 127 417</p> 	<p>025.271 2S6U 9441AA 1 149 707 2x</p> 	<p>a) 025.481 XS6E 6710A2B 1 089 838</p>  <p>b) 012.001 97JM 6730BA 1 013 938 M 14x1,5x20</p> <p>b) 176.090 97JM 6734BA 1 005 593 13x22,4x3</p>	<p>K:← 023.740 2S6G 6D316AA 1 219 337 ASW RD PTFE/ACM 40x62x7,4</p> <p>K:→ 023.950 2S6G 6A321BA 1 388 409 IWD LD PTFE 79,33x131,3x19</p>	

FORD 					
J4C J4J J4L J4N J4Q J4S JJA JJC JJE JJG JJJ JJL JKKC 4 Cyl. 1299 ccm Cyl. 74,0 Ø Courier 07/1997 → 08/1999 Fiesta 08/1995 → 08/2003 Ka 09/1996 → 11/2008	J4D J4K J4M J4P J4R J4T JB JJD JJF JJH JJK JJM	ES⊕ 129.800 96BX 6014AA 1 016 155 +96BM 6051A2A +1 000 389 CS* 104.280 96BX 6013AA 1 016 149  AL CS* 424.560 93BX 6013BA 5 028 398  FE	445.920 96BM 6051A2A 1 000 389 1,00 mm $\frac{3}{4}$ 75,5 Ø 	ZKS 802.910 6 184 406 (10x) M 11x1,5x121 	087.262 96BM 6584A1A 1 000 438 
JBA JBD JLB 4 Cyl. 1299 ccm Cyl. 74,0 Ø Escort 01/1986 → 12/1994 Fiesta 03/1989 → 12/1995 Orion 12/1985 → 07/1990	JBB JLA	S⊕* 766.691 ● 08/1988→  FE ES⊕ 751.066 ● 93BX 6014AA 5 028 400 +86BM 6051B1B +5 026 593 →08/1988 ES⊕ 766.704 93BX 6014AA 5 028 399 +1 000 389 08/1988→ CS* 424.560 93BX 6013BA 5 028 398 08/1988→  FE	561.951 ● 86BM 6051B2B 5 026 593 80 Ø →08/1988 445.920 96BM 6051A2A 1 000 389 1,00 mm $\frac{3}{4}$ 75,5 Ø 08/1988→  	ZKS 802.910 6 184 406 (10x) M 11x1,5x121 08/1988→ 	087.262 96BM 6584A1A 1 000 438 →08/1988 

			<p>a) </p> <p>b) </p>	<p>K: </p> <p>N: </p>	
<p>766.615 88WM 6571A2A 6 166 533 FPM 8x</p>	<p>916.295 95BM 9448AC 7 126 483 4x</p> 	<p>362.141 XS6G 9441AA 1 000 147</p> 	<p>a) OWS 751.040 96BX 6013CA 1 016 152</p>  <p>FE</p>  <p>a) 916.261 96BM 6710A2A 1 002 814</p>  <p>AL</p>  <p>b) 012.001 97JM 6730BA 1 013 938 M 14x1,5x20</p> <p>b) 176.090 97JM 6734BA 1 005 593 13x22,4x3</p> <p>b) 786.500 928M 6734AA 1 454 118 Nylon A 14,5x22x2</p>	<p>K:← 586.730 83BM 6700A4A 6 139 049 ASW RD VMQ 36,51x52,48x8</p> <p>K:→ 550.680 1 032 209 ASW LD PTFE/FPM 79,33x95,28x11</p> <p>K:→ 763.713 86HM 6701A1A 1 641 893 AW/BS LD FPM 79,33x95,25x11</p>	
<p>766.615 88WM 6571A2A 6 166 533 FPM 08/1988→ 8x</p> <p>206.954 70HM 6571A3B 1 490 525 ACM →08/1988 E 4x</p> 	<p>103.706 77BM 9448EB 5 026 592 →08/1988 4x</p>  <p>916.295 95BM 9448AC 7 126 483 08/1988→ 4x</p> 	<p>102.823 77BM 9441DB 5 026 591 →08/1988</p>  <p>765.112 89BM 9441AB 6 173 339 08/1988→</p> 	<p>a) OWS 751.040 96BX 6013CA 1 016 152</p>  <p>FE</p>  <p>b) 786.500 928M 6734AA 1 454 118 Nylon A 14,5x22x2</p>	<p>K:← 586.730 83BM 6700A4A 6 139 049 ASW RD VMQ 36,51x52,48x8</p> <p>K:→ 550.680 1 032 209 ASW LD PTFE/FPM 79,33x95,28x11</p> <p>K:→ 763.713 86HM 6701A1A 1 641 893 AW/BS LD FPM 79,33x95,25x11</p>	

<p>FORD</p> 				
<p>J4B J6B JBE</p> <p>J6A JBC</p> <p>4 Cyl. 1299 ccm Cyl. 74,0 Ø</p> <p>Escort 07/1990 → 02/1999</p> <p>Fiesta 03/1989 → 01/2002</p> <p>Orion 07/1990 → 12/1993</p>	<p>S⊕* 766.691 ● →08/1995</p>  <p>FE</p> <p>ES⊕ 766.704 93BX 6014AA 5 028 399 +1 000 389 →08/1995</p> <p>ES⊕ 129.800 96BX 6014AA 1 016 155 +96BM 6051A2A +1 000 389 09/1995→</p> <p>CS* 104.280 96BX 6013AA 1 016 149</p>  <p>AL</p> <p>CS* 424.560 93BX 6013BA 5 028 398</p>  <p>FE</p>	<p>445.920 96BM 6051A2A 1 000 389 1,00 mm ± 75,5 Ø</p> 	<p>ZKS 802.910 6 184 406 (10x) M 11x1,5x121</p> 	<p>087.262 96BM 6584A1A 1 000 438</p> 
<p>ASDA ASDB</p> <p>4 Cyl. 1388 ccm Cyl. 76,0 Ø</p> <p>Focus 07/2004 → 09/2012</p>	<p>ES⊕ 388.961 →06/2009</p> <p>ES⊕ 221.290 06/2009→</p>   <p>CS* 389.000</p>	<p>255.040 3S4G 6051AA 1 253 984 0,32 mm ± 77 Ø →06/2009</p>  <p>457.551 8A6G 6051DA 1 538 348 0,32 mm ± 77 Ø 06/2009→</p> 	<p>ZKS 087.830 1 765 604 (10x) M 10x1,5x143</p> 	<p>389.110</p>  <p>AL</p>  <p>761.031 1S6G 6K260AA 1 141 575</p> <p>PLASTIC</p>  
<p>FHA FHE FVKB</p> <p>FHD FHF</p> <p>4 Cyl. 1388 ccm Cyl. 76,0 Ø</p> <p>Courier 07/1997 → 08/1999</p> <p>Fiesta 04/1996 → 04/2002</p> <p>Puma 11/1997 → 10/2000</p>	<p>ES⊕ 023.551 96MX 6014AA 1 015 369</p>   <p>CS* 023.660 96MX 6013AA 1 015 368</p>	<p>646.813 1 304 003 →05/1998</p> <p>287.630 98MM 6051AC 1 303 769 0,50 mm ± 77 Ø 05/1998→</p>  	<p>ZKS 087.830 1 765 604 (10x) M 10x1,5x143</p> 	<p>389.110</p>  <p>AL</p>  <p>761.031 1S6G 6K260AA 1 141 575</p> <p>PLASTIC</p>  

			<p>a) </p> <p>b) </p>	<p>K: </p> <p>N: </p>	
<p>766.615 88WM 6571A2A 6 166 533 FPM 8x</p>	<p>916.295 95BM 9448AC 7 126 483 4x</p> 	<p>765.112 89BM 9441AB 6 173 339 →08/1995</p>  <p>362.141 XS6G 9441AA 1 000 147 09/1995→</p> 	<p>a) OWS 751.040 96BX 6013CA 1 016 152</p>  <p>FE</p>  <p>a) 916.261 96BM 6710A2A 1 002 814</p>  <p>AL</p>  <p>b) 786.500 928M 6734AA 1 454 118 Nylon A 14,5x22x2</p>	<p>K:← 586.730 83BM 6700A4A 6 139 049 ASW RD VMQ 36,51x52,48x8</p> <p>K:→ 550.680 1 032 209 ASW LD PTFE/FPM 79,33x95,28x11</p> <p>K:→ 763.713 86HM 6701A1A 1 641 893 AW/BS LD FPM 79,33x95,25x11</p>	
<p>VAS 398.450 026.700 96MM 6571AG 1 148 124 FPM E 8x</p> <p>026.670 96MM 6571BG 1 148 123 FPM A 8x</p>	<p>377.811 2S6G 9448DA 1 326 381</p> 	<p>025.260 2S6G 9441CA 1 142 502 4x</p> 	<p>a) 036.164 Dirko HT / EU</p> <p>a) 510.031 Dirko HT / USA/CDN/MEX</p> <p>a) 527.291 Dirko HT / RU</p> <p>a) 648.661 Dirko HT / BR</p> <p>b) 012.001 97JM 6730BA 1 013 938 M 14x1,5x20</p> <p>b) 176.090 97JM 6734BA 1 005 593 13x22,4x3</p>	<p>K:← 023.590 YS6G 6700AA 1 112 945 ASW RD FPM 33x47x5</p> <p>K:→ 023.862 1S4G-6K301AB 1 211 161 SP LD PTFE 80</p> <p>N:← 023.520 6M5G 6K292BA 1 471 482 ASW RD FPM 38x52x6 2x</p>	
<p>VAS 398.450 026.700 96MM 6571AG 1 148 124 FPM E 8x</p> <p>026.670 96MM 6571BG 1 148 123 FPM A 8x</p>	<p>864.221 98MM 9448AB 1 072 066</p> 	<p>025.280 96MM 9441AD 1 004 476 2x</p>	<p>a) 025.450 96MM 6710AD 1 004 459</p>  <p>b) 012.001 97JM 6730BA 1 013 938 M 14x1,5x20</p> <p>b) 176.090 97JM 6734BA 1 005 593 13x22,4x3</p>	<p>K:← 023.590 YS6G 6700AA 1 112 945 ASW RD FPM 33x47x5</p> <p>K:→ 023.862 1S4G-6K301AB 1 211 161 SP LD PTFE 80</p> <p>N:← 023.520 6M5G 6K292BA 1 471 482 ASW RD FPM 38x52x6 2x</p>	

FORD

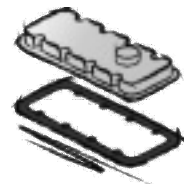
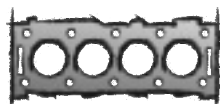
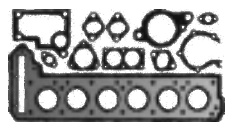

FXDA **FXDB**
FXDC **FXDD**

4 Cyl. **1388 ccm**
Cyl. 76,0 Ø

Focus
10/1998 → 03/2005

ES⊕ **388.981**
→12/2002



ES⊕ **389.021**
12/2002→



CS* **388.970**
→12/1999

CS* **389.010**
12/1999→



287.630
98MM 6051AC
1 303 769
0,50 mm $\frac{+}{-}$ 77 Ø
→12/2002



255.040
3S4G 6051AA
1 253 984
0,32 mm $\frac{+}{-}$ 77 Ø
12/2002→

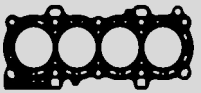

ZKS 087.830
1 765 604 (10x)
M 10x1,5x143



389.110

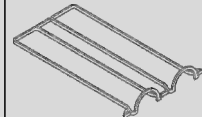

761.031
1S6G 6K260AA
1 141 575



FXJA **FXJB**
FXJC

4 Cyl. **1388 ccm**
Cyl. 76,0 Ø

Fiesta
11/2001 → 06/2008

Fusion
08/2002 → 12/2012

ES⊕ **024.961**
→10/2003



ES⊕ **221.290**
11/2003→



CS* **025.510**

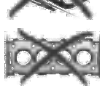

287.630
98MM 6051AC
1 303 769
0,50 mm $\frac{+}{-}$ 77 Ø
→08/2003



255.040
3S4G 6051AA
1 253 984
0,32 mm $\frac{+}{-}$ 77 Ø
09/2003→
→10/2008

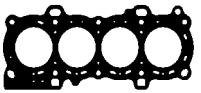

457.551
8A6G 6051DA
1 538 348
0,32 mm $\frac{+}{-}$ 77 Ø
11/2008→

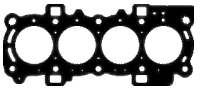

ZKS 087.830
1 765 604 (10x)
M 10x1,5x143

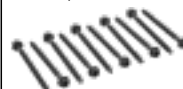

389.110

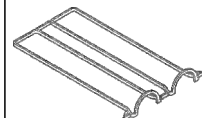

761.031
1S6G 6K260AA
1 141 575

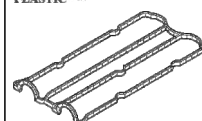

RTJA **RTJB**
SPJA **SPJC**

4 Cyl. **1388 ccm**
Cyl. 76,0 Ø

Fiesta
10/2008 → 04/2017

ES⊕ **191.640**
→12/2012

CS* **752.860**
→12/2012



457.551
8A6G 6051DA
1 538 348
0,32 mm $\frac{+}{-}$ 77 Ø

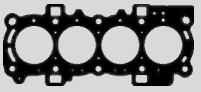

















ZKS 087.830
1 765 604 (10x)
M 10x1,5x143

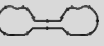
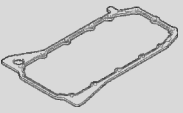

761.031
1S6G 6K260AA
1 141 575



			<p>a) </p> <p>b) </p>	<p>K: </p> <p>N: </p>	
<p>VAS 398.450 026.700 96MM 6571AG 1 148 124 FPM E 8x 026.670 96MM 6571BG 1 148 123 FPM A 8x</p>	<p>864.221 98MM 9448AB 1 072 066 →11/2003  377.811 2S6G 9448DA 1 326 381 11/2003→ </p>	<p>377.170 98MM 9441AA 1 072 063 2x </p>	<p>a) 025.450 96MM 6710AD 1 004 459 →12/1999 </p> <p>a) 036.164 Dirko HT / EU 12/1999→</p> <p>a) 510.031 Dirko HT / USA/CDN/MEX 12/1999→</p> <p>a) 527.291 Dirko HT / RU 12/1999→</p> <p>a) 648.661 Dirko HT / BR 12/1999→</p> <p>b) 012.001 97JM 6730BA 1 013 938 M 14x1,5x20</p> <p>b) 176.090 97JM 6734BA 1 005 593 13x22,4x3</p>	<p>K:← 023.590 YS6G 6700AA 1 112 945 ASW RD FPM 33x47x5 K:→ 023.862 1S4G-6K301AB 1 211 161 SP LD PTFE 80 N:← 023.520 6M5G 6K292BA 1 471 482 ASW RD FPM 38x52x6 2x</p>	
<p>VAS 398.450 026.700 96MM 6571AG 1 148 124 FPM E 8x 026.670 96MM 6571BG 1 148 123 FPM A 8x</p>	<p>024.940 97MF 9448AA 1 031 021 →10/2003  377.811 2S6G 9448DA 1 326 381 11/2003→ </p>	<p>025.260 2S6G 9441CA 1 142 502 4x </p>	<p>a) 036.164 Dirko HT / EU</p> <p>a) 510.031 Dirko HT / USA/CDN/MEX</p> <p>a) 527.291 Dirko HT / RU</p> <p>a) 648.661 Dirko HT / BR</p> <p>b) 012.001 97JM 6730BA 1 013 938 M 14x1,5x20</p> <p>b) 176.090 97JM 6734BA 1 005 593 13x22,4x3</p>	<p>K:← 023.590 YS6G 6700AA 1 112 945 ASW RD FPM 33x47x5 K:→ 023.862 1S4G-6K301AB 1 211 161 SP LD PTFE 80 N:← 023.520 6M5G 6K292BA 1 471 482 ASW RD FPM 38x52x6 2x</p>	
<p>VAS 398.450 026.700 96MM 6571AG 1 148 124 FPM E 8x 026.670 96MM 6571BG 1 148 123 FPM A 8x</p>	<p>377.811 2S6G 9448DA 1 326 381 </p>	<p>537.630 4M5G 9441FA 1 338 179 →12/2012 4x  753.020 1 538 577 12/2012→ 4x </p>	<p>a) 036.164 Dirko HT / EU</p> <p>a) 510.031 Dirko HT / USA/CDN/MEX</p> <p>a) 527.291 Dirko HT / RU</p> <p>a) 648.661 Dirko HT / BR</p> <p>b) 012.001 97JM 6730BA 1 013 938 M 14x1,5x20</p> <p>b) 176.090 97JM 6734BA 1 005 593 13x22,4x3</p>	<p>K:← 023.590 YS6G 6700AA 1 112 945 ASW RD FPM 33x47x5 K:→ 023.862 1S4G-6K301AB 1 211 161 SP LD PTFE 80 N:← 023.520 6M5G 6K292BA 1 471 482 ASW RD FPM 38x52x6 2x</p>	

FORD

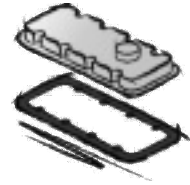
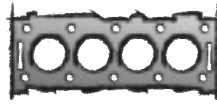
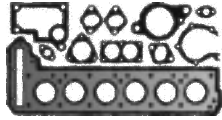

RTJC **RTJD**
SPJD **SPJE**

4 Cyl. **1388 ccm**
Cyl. 76,0 Ø

B-Max
10/2012 →

Fiesta
10/2008 → 04/2017

457.551
8A6G 6051DA
1 538 348
0,32 mm \pm 77 Ø

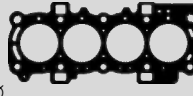

ZKS 087.830
1 765 604 (10x)
M 10x1,5x143



761.031
1S6G 6K260AA
1 141 575

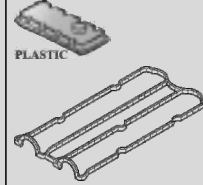

UTJA

4 Cyl. **1388 ccm**
Cyl. 76,0 Ø

Fusion
01/2010 → 12/2012

457.551
8A6G 6051DA
1 538 348
0,32 mm \pm 77 Ø

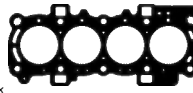

ZKS 087.830
1 765 604 (10x)
M 10x1,5x143



761.031
1S6G 6K260AA
1 141 575

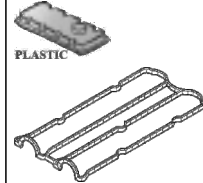

F4A F4B

4 Cyl. **1392 ccm**
Cyl. 77,2 Ø

Escort
09/1990 → 08/2000

Fiesta
03/1989 → 12/1995

S \oplus * **704.939**
86SX 6014AA
5 016 203
→01/1994

ES \oplus **704.947**
93SX 6014AB
1 008 718
+92SM 6051AB
+6 918 548
→01/1994

ES \oplus **027.890**
01/1994→

CS* **762.874**
93SX 6013BA
5 028 484

892.815
92SM 6051AB
6 918 548
1,75 mm \pm 80 Ø





















ZKS 820.490
6 088 344 (10x)
M 10x1,5x135



764.221
88SM 6584AA
1 651 775

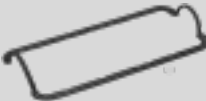

			<p>a) </p> <p>b) </p>	<p>K: </p> <p>N: </p>	
<p>VAS 398.450 026.700 96MM 6571AG 1 148 124 FPM E 8x</p> <p>026.670 96MM 6571BG 1 148 123 FPM A 8x</p>	<p>377.811 2S6G 9448DA 1 326 381</p> 	<p>753.020 1 538 577 4x</p> 	<p>a) 036.164 Dirko HT / EU</p> <p>a) 510.031 Dirko HT / USA/CDN/MEX</p> <p>a) 527.291 Dirko HT / RU</p> <p>a) 648.661 Dirko HT / BR</p> <p>b) 012.001 97JM 6730BA 1 013 938 M 14x1,5x20</p> <p>b) 176.090 97JM 6734BA 1 005 593 13x22,4x3</p>	<p>K:← 023.590 YS6G 6700AA 1 112 945 ASW RD FPM 33x47x5</p> <p>K:→ 023.862 1S4G-6K301AB 1 211 161 SP LD PTFE 80</p> <p>N:← 023.520 6M5G 6K292BA 1 471 482 ASW RD FPM 38x52x6 2x</p>	
<p>VAS 398.450 026.700 96MM 6571AG 1 148 124 FPM E 8x</p> <p>026.670 96MM 6571BG 1 148 123 FPM A 8x</p>	<p>377.811 2S6G 9448DA 1 326 381</p> 	<p>025.260 2S6G 9441CA 1 142 502 4x</p> 	<p>a) 036.164 Dirko HT / EU</p> <p>a) 510.031 Dirko HT / USA/CDN/MEX</p> <p>a) 527.291 Dirko HT / RU</p> <p>a) 648.661 Dirko HT / BR</p> <p>b) 012.001 97JM 6730BA 1 013 938 M 14x1,5x20</p> <p>b) 176.090 97JM 6734BA 1 005 593 13x22,4x3</p>	<p>K:← 023.590 YS6G 6700AA 1 112 945 ASW RD FPM 33x47x5</p> <p>K:→ 023.862 1S4G-6K301AB 1 211 161 SP LD PTFE 80</p> <p>N:← 023.520 6M5G 6K292BA 1 471 482 ASW RD FPM 38x52x6 2x</p>	
<p>405.990 81SM 6571A2F 6 674 302 FPM 8x</p>	<p>705.811 91SM 9448AB 6 591 016 →01/1994</p>  <p>318.974 91SM 9448BB 6 591 017 01/1994→</p> 	<p>318.968 92SM 9441AA 6 851 355 →01/1994</p>  <p>711.662 94SM 9441AB 6 930 966 01/1994→</p> 	<p>a) OWS 388.940 6 166 108 +1 454 118</p>  <p>a) 587.486 88SM 6710AA 6 166 108</p>  <p>b) 786.500 928M 6734AA 1 454 118 Nylon A 14,5x22x2</p>	<p>K:← 757.292 928M 6700B5A 6 165 500 ASW RD FPM 35x50x7</p> <p>K:→ 750.476 928M 6701B5A 6 126 179 ASW LD FPM 88x108x11</p> <p>N:← 757.497 86HM 6700AA 1 669 254 ASW RD FPM 42x56x7</p>	

FORD

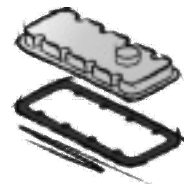
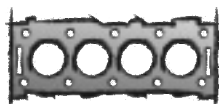
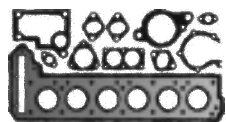

F6A **F6B**
F6C **F6D**
F6E **F6F**
F6G **FUA**
FUAA **FUB**
FUBA **FUC**
FUD **FUF**
FUG **FUH**
FUJ

4 Cyl. **1392 ccm**
 Cyl. 77,2 Ø

Escort
 10/1985 → 02/1999
Fiesta
 09/1983 → 12/1996
Orion
 12/1985 → 12/1993

S⊕* **704.939**
 86SX 6014AA
 5 016 203
 ES⊕ **704.947**
 93SX 6014AB
 1 008 718
 +92SM 6051AB
 +6 918 548
 CS* **762.874**
 93SX 6013BA
 5 028 484

892.815
 92SM 6051AB
 6 918 548
 1,75 mm $\frac{1}{16}$ 80 Ø



ZKS 820.490
 6 088 344 (10x)
 M 10x1,5x135



764.221
 88SM 6584AA
 1 651 775



F6JA **F6JB**
F6JC **F6JD**

4 Cyl. **1399 ccm**
 Cyl. 73,7 Ø

Fiesta TDCi
 11/2001 →
Fusion TDCi
 08/2002 → 12/2012

S⊕* **726.090**

 ES⊕ **030.760**

 CS* **030.780**
 OKS **027.170**

 OKS **747.080**

100.400
 2S6Q 6051AA
 1 146 049

 0,618 mm
 →
 0,725 mm
 1,25 mm $\frac{1}{16}$ 75 Ø
 2 ▽

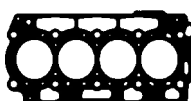

100.410
 2S6Q 6051BA
 1 146 050

 0,726 mm
 →
 0,775 mm
 1,30 mm $\frac{1}{16}$ 75 Ø
 3 ▽

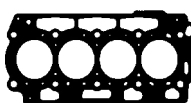

100.420
 2S6Q 6051CA
 1 146 051

 0,776 mm
 →
 0,825 mm
 1,35 mm $\frac{1}{16}$ 75 Ø
 1 ▽

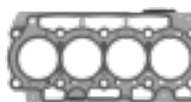

100.430
 2S6Q 6051DA
 1 146 052

 0,826 mm
 →
 0,875 mm
 1,40 mm $\frac{1}{16}$ 75 Ø
 4 ▽

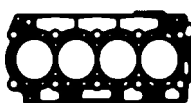

100.440
 2S6Q 6051EA
 1 146 053

 0,876 mm
 →
 0,983 mm
 1,45 mm $\frac{1}{16}$ 75 Ø
 5 ▽

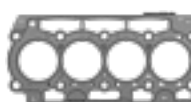

ZKS 330.390
 1 229 885 (10x)
 M 11x1,5x147

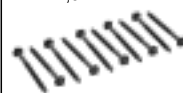







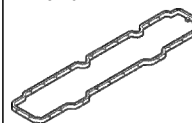







ZKHS 428.960



027.730
 2S6Q 6P038AA
 1 148 101

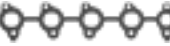

			<p>a) </p> <p>b) </p>	<p>K: </p> <p>N: </p>	
<p>405.990 81SM 6571A2F 6 674 302 FPM 8x</p>	<p>705.811 91SM 9448AB 6 591 016</p> 	<p>318.968 92SM 9441AA 6 851 355</p> 	<p>a) OWS 388.940 6 166 108 +1 454 118</p>  <p>a) 587.486 88SM 6710AA 6 166 108</p>  <p>b) 786.500 928M 6734AA 1 454 118 Nylon A 14,5x22x2</p>	<p>K:← 757.292 928M 6700B5A 6 165 500 ASW RD FPM 35x50x7</p> <p>K:→ 750.476 928M 6701B5A 6 126 179 ASW LD FPM 88x108x11</p> <p>N:← 757.497 86HM 6700AA 1 669 254 ASW RD FPM 42x56x7</p>	
<p>VAS 261.330 FPM</p> <p>027.750 2S6Q 6571AA 1 145 937 FPM 8x</p>	<p>761.041 2S6Q 9448AB 1 148 115</p> 	<p>AAS 428.960</p>  <p>027.160 1 148 106 4x</p>	<p>a) 036.164 Dirko HT / EU</p> <p>a) 510.031 Dirko HT / USA/CDN/MEX</p> <p>a) 527.291 Dirko HT / RU</p> <p>a) 648.661 Dirko HT / BR</p> <p>b) 877.930 incl. 108.502 M 10x1,25x13</p> <p>b) 108.502 2S6Q 6734AA 1 145 962 CU A 10x21x2,1</p>	<p>K:← 026.750 2S6Q 6700AA 1 142 359 ASW RD PTFE/FPM 40x55x6,4</p> <p>K:→ 026.790 2S6Q 6701AA 1 142 360 ASW LD PTFE/FPM 85x105x8,8</p> <p>N:← 026.740 2S6Q 6L270AA 1 145 953 ASW RD PTFE/ACM 27x47x7</p>	<p>TLS 714.590</p> 

FORD

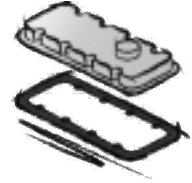
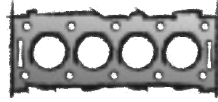
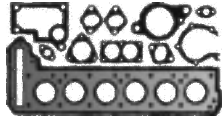

KVJA
4 Cyl. **1399 ccm**
Cyl. 73,7 Ø

Fiesta TDCi
05/2002 →

S⊕* **726.090**



ES⊕ **570.920**



OKS **027.170**



OKS **747.080**

490.001
AV2Q-6051AA
1 703 259
1,25 mm ± 74,7 Ø
2 ▽

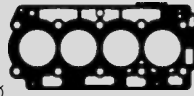

490.011
AV2Q-6051BA
1 703 267
1,30 mm ± 74,7 Ø
3 ▽



490.021
AV2Q-6051CA
1 703 268
1,35 mm ± 74,7 Ø
1 ▽



490.031
AV2Q-6051DA
1 703 270
1,40 mm ± 74,7 Ø
4 ▽



490.041
AV2Q-6051EA
1 703 275
1,45 mm ± 74,7 Ø
5 ▽



ZKS 330.390
1 229 885 (10x)
M 11x1,5x147



453.420
1 704 086



BNMA BNMB
BNMC C15HDTX
M8DA M8DB
M8DD M8DE
M8DF M8MA
M8MB M8MC
M8MD M8ME
M9DA M9DB
M9DG M9DH
M9MA M9MB
M9MC M9MD
M9ME UNCA
UNCB UNCC
UNCD UNCE
UNCF UNCG
UNCH UNCI
UNCJ UNCK
UNCM UNCN
UNCP

4 Cyl. **1498 ccm**
Cyl. 79,0 Ø

C-Max
03/2015 → 06/2019

Focus
09/2014 →

Galaxy
01/2015 →

Grand C-Max
03/2015 → 06/2019

Kuga
09/2014 →

Mondeo
09/2014 →

S-Max
01/2015 →

ES⊕ **460.600**
1 891 382

CS* **465.770**



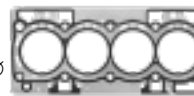









460.970
1 845 570
0,60 mm ± 80,3 Ø



ZKS 087.830
1 765 604 (10x)
M 10x1,5x143



461.100
DS7G-6584-BA
1 849 927

			<p>a) </p> <p>b) </p>	<p>K: </p> <p>N: </p>	
<p>VAS 261.330 FPM 027.750 2S6Q 6571AA 1 145 937 FPM 8x</p>	<p>284.680 1 690 577</p> 	<p>341.080 AV6Q-6C653AA 1 699 542</p> 	<p>a) 036.164 Dirko HT / EU a) 510.031 Dirko HT / USA/CDN/MEX a) 527.291 Dirko HT / RU a) 648.661 Dirko HT / BR b) 877.930 incl. 108.502 M 10x1,25x13 b) 108.502 2S6Q 6734AA 1 145 962 CU A 10x21x2,1</p>	<p>K:← 026.750 2S6Q 6700AA 1 142 359 ASW RD PTFE/FPM 40x55x6,4 K:→ 026.790 2S6Q 6701AA 1 142 360 ASW LD PTFE/FPM 85x105x8,8 N:← 026.740 2S6Q 6L270AA 1 145 953 ASW RD PTFE/ACM 27x47x7</p>	<p>TLS 430.160</p> 
<p>317.020 BM5G-6571-CA 1 791 865 FPM 16x</p>	<p>461.090 1 814 569</p> 	<p>461.120 DS7G-9439-AA 1 837 186</p>	<p>a) 036.164 Dirko HT / EU a) 510.031 Dirko HT / USA/CDN/MEX a) 527.291 Dirko HT / RU a) 648.661 Dirko HT / BR b) 012.001 97JM 6730BA 1 013 938 M 14x1,5x20 b) 176.090 97JM 6734BA 1 005 593 13x22,4x3</p>	<p>K:← 023.590 YS6G 6700AA 1 112 945 ASW RD FPM 33x47x5 K:→ 023.862 1S4G-6K301AB 1 211 161 SP LD PTFE 80 N:← 542.030 4M5G 6K292CB 1 319 178 ASW RD FPM 46x56,4x7 2x</p>	<p>TLS 464.200</p>

FORD

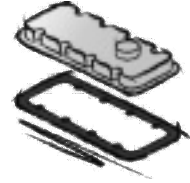
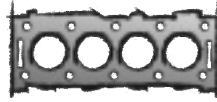
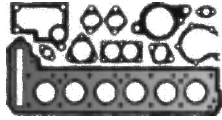

C154CSG
UEJB

4 Cyl. 1499 ccm
Cyl. 79,0 Ø

Ecosport
10/2013 →
Fiesta
04/2012 →
Ka
08/2014 →

ES⊕ **226.400**
CS* **539.410**

362.832
7S7G 6051XB
1 471 557
0,32 mm $\frac{1}{32}$ 79,8 Ø

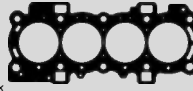

ZKS 087.830
1 765 604 (10x)
M 10x1,5x143



010.051
4M5G 6K260CA
1 319 177

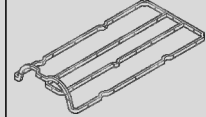

XUGA **XVGA**
XVGB **XVGC**
XWGA **XWGB**
XWGC **XXGA**

4 Cyl. 1499 ccm
Cyl. 73,5 Ø

Tourneo Connect TDCi
05/2015 →
Transit Connect TDCi
05/2015 →

S⊕* **726.090**



ES⊕ **570.920**

OKS **027.170**



OKS **747.080**

490.001
AV2Q-6051AA
1 703 259
1,25 mm $\frac{1}{16}$ 74,7 Ø
2 ▽

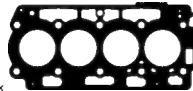

490.011
AV2Q-6051BA
1 703 267
1,30 mm $\frac{1}{16}$ 74,7 Ø
3 ▽

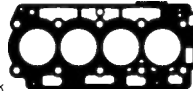

490.021
AV2Q-6051CA
1 703 268
1,35 mm $\frac{1}{16}$ 74,7 Ø
1 ▽

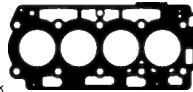

490.031
AV2Q-6051DA
1 703 270
1,40 mm $\frac{1}{16}$ 74,7 Ø
4 ▽



490.041
AV2Q-6051EA
1 703 275
1,45 mm $\frac{1}{16}$ 74,7 Ø
5 ▽













ZKS 330.390
1 229 885 (10x)
M 11x1,5x147

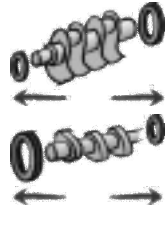

453.420
1 704 086



					
<p> VAS 398.450 026.700 96MM 6571AG 1 148 124 FPM E 8x 026.670 96MM 6571BG 1 148 123 FPM A 8x </p>	<p> 377.811 2S6G 9448DA 1 326 381  </p>	<p> 537.630 4M5G 9441FA 1 338 179 4x  </p>	<p> a) 036.164 Dirko HT / EU a) 510.031 Dirko HT / USA/CDN/MEX a) 527.291 Dirko HT / RU a) 648.661 Dirko HT / BR b) 012.001 97JM 6730BA 1 013 938 M 14x1,5x20 b) 176.090 97JM 6734BA 1 005 593 13x22,4x3 </p>	<p> K:← 023.590 YS6G 6700AA 1 112 945 ASW RD FPM 33x47x5 K:→ 023.862 1S4G-6K301AB 1 211 161 SP LD PTFE 80 N:← 542.030 4M5G 6K292CB 1 319 178 ASW RD FPM 46x56,4x7 2x </p>	
<p> VAS 261.330 FPM 027.750 2S6Q 6571AA 1 145 937 FPM 8x </p>	<p> 284.680 1 690 577  </p>	<p> 341.080 AV6Q-6C653AA 1 699 542  </p>	<p> a) 036.164 Dirko HT / EU a) 510.031 Dirko HT / USA/CDN/MEX a) 527.291 Dirko HT / RU a) 648.661 Dirko HT / BR b) 877.930 incl. 108.502 M 10x1,25x13 b) 108.502 2S6Q 6734AA 1 145 962 CU A 10x21x2,1 b) 813.052 CU C 16x22x2 </p>	<p> K:← 026.750 2S6Q 6700AA 1 142 359 ASW RD PTFE/FPM 40x55x6,4 K:→ 026.790 2S6Q 6701AA 1 142 360 ASW LD PTFE/FPM 85x105x8,8 N:← 026.740 2S6Q 6L270AA 1 145 953 ASW RD PTFE/ACM 27x47x7 </p>	<p> TLS 430.160  </p>

FORD

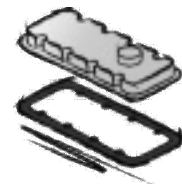
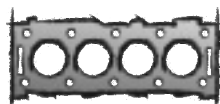
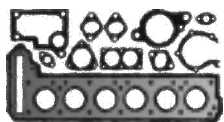

15DSOX **AEDA**
UGCA **UGCB**
UGCC **UGJC**
UGJE **UGJG**
UGJM **XUCA**
XUCC **XUCD**
XUCE **XUJA**
XUJB **XUJC**
XUJD **XUJE**
XUJF **XUJG**
XUJH **XUJK**
XUJL **XUJM**
XUJN **XVCA**
XVCB **XVCC**
XVCD **XVJA**
XVJB **XVJC**
XVJD **XVJE**
XWCA **XWCB**
XWDA **XWDB**
XWDC **XWDD**
XWDE **XWJA**
XWJB **XWJC**
XWMA **XWMB**
XWMC **XXCA**
XXCB **XXCC**
XXDA **XXDB**
XXDC **XXDD**

4 Cyl. 1499 ccm
Cyl. 73,5 Ø

B-Max TDCi
 10/2012 →
C-Max TDCi
 03/2015 → 06/2019
Ecosport TDCi
 10/2012 →
Fiesta
 05/2017 →
Fiesta TDCi
 01/2011 →
Focus TDCi
 09/2014 →
Grand C-Max TDCi
 03/2015 → 06/2019
Ka TDCi
 09/2015 →
Kuga TDCi
 07/2016 →
Mondeo TDCi
 03/2015 →
Tourneo Courier TDCi
 02/2014 →
Transit Courier
 04/2018 →
Transit Courier TDCi
 02/2014 →

S⊕* **726.090**



ES⊕ **570.920**



OKS **027.170**



OKS **747.080**

490.001

AV2Q-6051AA

1 703 259

1,25 mm ± 74,7 Ø

2 ▽

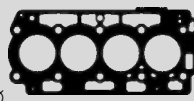

490.011

AV2Q-6051BA

1 703 267

1,30 mm ± 74,7 Ø

3 ▽

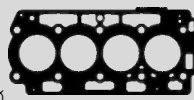

490.021

AV2Q-6051CA

1 703 268

1,35 mm ± 74,7 Ø

1 ▽

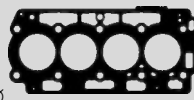

490.031

AV2Q-6051DA

1 703 270

1,40 mm ± 74,7 Ø

4 ▽

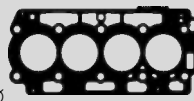

490.041

AV2Q-6051EA

1 703 275

1,45 mm ± 74,7 Ø

5 ▽

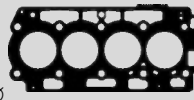

ZKS **330.390**

1 229 885 (10x)











M 11x1,5x147



453.420

1 704 086



			<p>a) </p> <p>b) </p>	<p>K: </p> <p>N: </p>	
<p>VAS 261.330 FPM</p> <p>027.750 2S6Q 6571AA 1 145 937 FPM 8x</p>	<p>284.680 1 690 577</p> 	<p>341.080 AV6Q-6C653AA 1 699 542</p> 	<p>a) 036.164 Dirko HT / EU</p> <p>a) 510.031 Dirko HT / USA/CDN/MEX</p> <p>a) 527.291 Dirko HT / RU</p> <p>a) 648.661 Dirko HT / BR</p> <p>b) 877.930 incl. 108.502 M 10x1,25x13</p> <p>b) 108.502 2S6Q 6734AA 1 145 962 CU A 10x21x2,1</p> <p>b) 813.052 CU C 16x22x2</p>	<p>K:← 026.750 2S6Q 6700AA 1 142 359 ASW RD PTFE/FPM 40x55x6,4</p> <p>K:→ 026.790 2S6Q 6701AA 1 142 360 ASW LD PTFE/FPM 85x105x8,8</p> <p>N:← 026.740 2S6Q 6L270AA 1 145 953 ASW RD PTFE/ACM 27x47x7</p>	<p>TLS 430.160</p> 

FORD

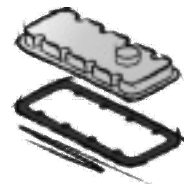
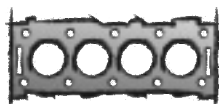
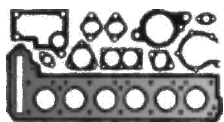

BEGA **Z2DA**
Z2GA **Z2JA**
ZTDA **ZTDB**
ZTGA **ZTJA**
ZTJB **ZTJC**

4 Cyl. **1499 ccm**
 Cyl. 75,0 Ø

Ecosport TDCi
 11/2017 →

Focus
 01/2018 →

Kuga
 07/2019 →

Tourneo Connect
 05/2018 →

Transit Connect
 05/2015 →

S⊕* **967.070**



ES⊕ **967.050**



CS* **967.060**

OKS **907.240**
 JX6Q-6A646-AA
 2 189 427

330.971

JX6Q-6051-AB
 2 189 860

1,25 mm $\frac{\pm}{\pm}$ 76,3 Ø
 2 ▽

330.981

JX6Q-6051-BB
 2 189 869

1,30 mm $\frac{\pm}{\pm}$ 76,3 Ø
 3 ▽

330.991

JX6Q-6051-CB
 2 189 872

1,35 mm $\frac{\pm}{\pm}$ 76,3 Ø
 1 ▽

331.001

JX6Q-6051-DB
 2 189 877

1,40 mm $\frac{\pm}{\pm}$ 76,3 Ø
 4 ▽

331.011

JX6Q-6051-EB
 2 189 896

1,45 mm $\frac{\pm}{\pm}$ 76,3 Ø
 5 ▽

ZKS **330.390**



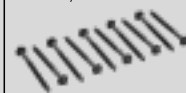





1 229 885 (10x)
 M 11x1,5x147



ZKHS **907.170**

929.060
 JX6Q-6K780-AB
 2 191 035
 4x



			<p>a) </p> <p>b) </p>	<p>K: </p> <p>N: </p>	
<p>910.610 JX6Q-6571-AA 2 190 197 FPM 16x</p> 			<p>a) 036.164 Dirko HT / EU</p> <p>a) 510.031 Dirko HT / USA/CDN/MEX</p> <p>a) 527.291 Dirko HT / RU</p> <p>a) 648.661 Dirko HT / BR</p>	<p>K:← 964.160 JX6Q-6700BA 2 190 320 ASW RD PTFE/ACM 38x55x5,9</p> <p>K:→ 369.470 ASW LD PTFE/ACM 85x105x8</p> <p>N:← 966.950 JX6Q 6L270BA 2 191 039 ASW RD PTFE/ACM 24,7x42x6</p>	

FORD

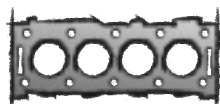
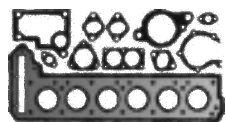

G8DA **G8DB**
G8DC **G8DD**
G8DE **G8DF**
GPDA **GPDB**
GPDC **HHDA**
HHDB **HHJA**
HHJB **HHJC**
HHJD **HHJE**
HHJF **MTDA**
UBJA

4 Cyl. **1560 ccm**
Cyl. 75,0 Ø

C-Max TDCi
02/2007 → 09/2010

Fiesta TDCi
11/2004 →

Focus C-Max TDCi
10/2003 → 03/2007

Focus TDCi
07/2004 → 09/2012

Fusion TDCi
11/2004 → 12/2012

S⊕* **456.780**



S⊕* **726.090**



ES⊕ **569.410**



CS* **030.780**

OKS **027.170**



OKS **747.080**

569.812

3M5Q 6051AA
1 229 877

0,533 mm
→
0,634 mm

1,25 mm $\frac{+}{-}$ 76 Ø

2 ⊗

2 ∇

569.822

3M5Q 6051BA
1 229 878

0,635 mm
→
0,684 mm

1,30 mm $\frac{+}{-}$ 76 Ø

3 ⊗

3 ∇

569.802

3M5Q 6051CA
1 229 879

0,685 mm
→
0,734 mm

1,35 mm $\frac{+}{-}$ 76 Ø

1 ⊗

1 ∇

569.832

3M5Q 6051DA
1 229 880

0,735 mm
→
0,784 mm

1,40 mm $\frac{+}{-}$ 76 Ø

4 ⊗

4 ∇

569.842

3M5Q 6051EA
1 229 881

0,785 mm
→
0,886 mm

1,45 mm $\frac{+}{-}$ 76 Ø

5 ⊗

5 ∇

ZKS **330.390**



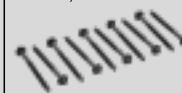









1 229 885 (10x)
M 11x1,5x147

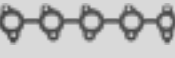

375.510

1 235 994



			<p>a) </p> <p>b) </p>	<p>K: </p> <p>N: </p>	
<p>262.650 3M5Q 6571AA 1 229 886 FPM 16x</p>	<p>761.041 2S6Q 9448AB 1 148 115</p> 	<p>AAS 429.040</p>  <p>389.041 3M5Q 6L004AA 1 254 375 4x</p>  <p>389.121 3M5Q 6L004BA 1 254 376 4x</p> 	<p>a) 036.164 Dirko HT / EU</p> <p>a) 510.031 Dirko HT / USA/CDN/MEX</p> <p>a) 527.291 Dirko HT / RU</p> <p>a) 648.661 Dirko HT / BR</p> <p>b) 877.930 incl. 108.502 M 10x1,25x13</p> <p>b) 108.502 2S6Q 6734AA 1 145 962 CU A 10x21x2,1</p>	<p>K:← 026.750 2S6Q 6700AA 1 142 359 ASW RD PTFE/FPM 40x55x6,4</p> <p>K:→ 026.790 2S6Q 6701AA 1 142 360 ASW LD PTFE/FPM 85x105x8,8</p> <p>N:← 026.740 2S6Q 6L270AA 1 145 953 ASW RD PTFE/ACM 27x47x7</p>	<p>TLS 714.600</p> 

FORD

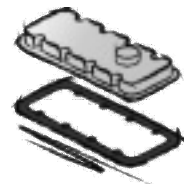
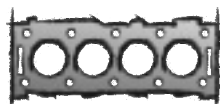
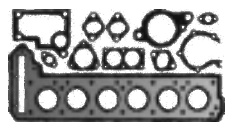

NGCA **NGDA**
NGDB **T1BA**
T1BB **T1BC**
T1DA **T1DB**
T1WA **T1WB**
T3CA **T3CB**
T3CC **T3DA**
T3DB **T3JA**
T3JB **TZJA**
TZJB **U3CA**

4 Cyl. **1560 ccm**
Cyl. 75,0 Ø

B-Max TDCi
 10/2012 →
C-Max TDCi
 12/2010 → 06/2019
Fiesta TDCi
 02/2010 →
Focus TDCi
 07/2010 →
Galaxy TDCi
 02/2011 → 06/2015
Grand C-Max TDCi
 12/2010 → 06/2019
Mondeo TDCi
 12/2010 →
S-Max TDCi
 02/2011 → 12/2014
Tourneo Courier TDCi
 02/2014 →
Transit Courier TDCi
 02/2014 →

S⊕* **726.090**



ES⊕ **570.920**



ES⊕ **995.620**



CS* **449.590**

OKS **027.170**



OKS **747.080**

718.311

AV6Q 6051AC

1 698 964

1,25 mm ± 76,3 Ø

2 ▽

718.321

AV6Q-6051BD

1 866 562

1,30 mm ± 76,3 Ø

3 ▽

718.331

AV6Q-6051CD

1 866 564

1,35 mm ± 76,3 Ø

1 ▽

718.341

AV6Q-6051DD

1 866 565

1,40 mm ± 76,3 Ø

4 ▽

718.351

AV6Q-6051EC

1 698 968

1,45 mm ± 76,3 Ø

5 ▽

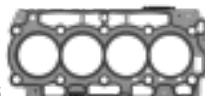
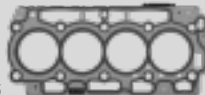
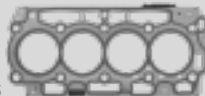

ZKS 330.390

1 229 885 (10x)

M 11x1,5x147



453.420

1 704 086



T1GA **TZGA**
TZGB **UBGA**

4 Cyl. **1560 ccm**
Cyl. 75,0 Ø

Tourneo Connect TDCi
 09/2013 →
Transit Connect TDCi
 02/2013 →

S⊕* **726.090**



ES⊕ **570.920**



ES⊕ **995.620**



CS* **449.590**

OKS **027.170**



OKS **747.080**

718.311

AV6Q 6051AC

1 698 964

1,25 mm ± 76,3 Ø

2 ▽

718.321

AV6Q-6051BD

1 866 562

1,30 mm ± 76,3 Ø

3 ▽

718.331

AV6Q-6051CD

1 866 564

1,35 mm ± 76,3 Ø

1 ▽

718.341

AV6Q-6051DD

1 866 565

1,40 mm ± 76,3 Ø

4 ▽

718.351

AV6Q-6051EC

1 698 968

1,45 mm ± 76,3 Ø

5 ▽

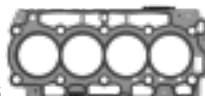

ZKS 330.390

1 229 885 (10x)















M 11x1,5x147











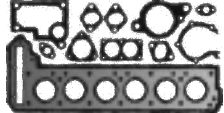
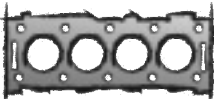

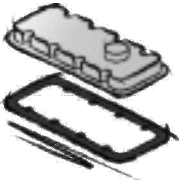





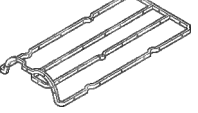







453.420

1 704 086



			<p>a) </p> <p>b) </p>	<p>K: </p> <p>N: </p>	
<p>VAS 261.330 FPM 027.750 2S6Q 6571AA 1 145 937 FPM 8x</p>	<p>284.680 1 690 577</p> 	<p>341.080 AV6Q-6C653AA 1 699 542</p> 	<p>a) 036.164 Dirko HT / EU</p> <p>a) 510.031 Dirko HT / USA/CDN/MEX</p> <p>a) 527.291 Dirko HT / RU</p> <p>a) 648.661 Dirko HT / BR</p> <p>b) 877.930 incl. 108.502 M 10x1,25x13</p> <p>b) 108.502 2S6Q 6734AA 1 145 962 CU A 10x21x2,1</p>	<p>K:← 026.750 2S6Q 6700AA 1 142 359 ASW RD PTFE/FPM 40x55x6,4</p> <p>K:→ 026.790 2S6Q 6701AA 1 142 360 ASW LD PTFE/FPM 85x105x8,8</p> <p>N:← 026.740 2S6Q 6L270AA 1 145 953 ASW RD PTFE/ACM 27x47x7</p>	<p>TLS 430.160</p> 
<p>VAS 261.330 FPM 027.750 2S6Q 6571AA 1 145 937 FPM 8x</p>	<p>284.680 1 690 577</p> 	<p>341.080 AV6Q-6C653AA 1 699 542</p> 	<p>a) 036.164 Dirko HT / EU →09/2013</p> <p>a) 510.031 Dirko HT / USA/CDN/MEX →09/2013</p> <p>a) 527.291 Dirko HT / RU →09/2013</p> <p>a) 648.661 Dirko HT / BR →09/2013</p> <p>b) 877.930 incl. 108.502 M 10x1,25x13 →09/2013</p> <p>b) 108.502 2S6Q 6734AA 1 145 962 CU A 10x21x2,1 →09/2013</p>	<p>K:← 026.750 2S6Q 6700AA 1 142 359 ASW RD PTFE/FPM 40x55x6,4</p> <p>K:→ 026.790 2S6Q 6701AA 1 142 360 ASW LD PTFE/FPM 85x105x8,8</p> <p>N:← 026.740 2S6Q 6L270AA 1 145 953 ASW RD PTFE/ACM 27x47x7</p>	<p>TLS 430.160</p> 

<p>FORD</p> 				
<p>LAC LAD LAR LCE LCJ LE LEC OHC TL 16 G/H TL 16M</p> <p>4 Cyl. 1593 ccm Cyl. 87,7 Ø</p> <p>Capri 08/1972 → 12/1977</p> <p>Cortina 10/1970 → 03/1972</p> <p>Escort 08/1969 → 11/1974</p> <p>Taunus 01/1970 → 12/1982</p>	<p>CS* 424.930 93HX 6013AA 5 028 466</p>	<p>896.691 ● 92HX 6051DA 5 051 959 1,30 mm $\frac{1}{2}$ 89,6 Ø</p> 		<p>217.484 71HM 6584KA 6 078 807</p> 
<p>C16HDEX/HDEZ HXDA HXDB SIDA</p> <p>4 Cyl. 1596 ccm Cyl. 79,0 Ø</p> <p>C-Max 04/2007 → 09/2010</p> <p>Fiesta 06/2010 →</p> <p>Focus 07/2004 →</p> <p>Focus C-Max 08/2004 → 03/2007</p>	<p>ES⊕ 569.970 →12/2007</p> <p>ES⊕ 226.400 12/2007→</p> <p>CS* 539.410</p>	<p>520.800 1 319 733 0,32 mm $\frac{1}{2}$ 79,8 Ø →12/2007</p>  <p>362.832 7S7G 6051XB 1 471 557 0,32 mm $\frac{1}{2}$ 79,8 Ø 12/2007→</p> 	<p>ZKS 087.830 1 765 604 (10x) M 10x1,5x143</p> 	<p>010.051 4M5G 6K260CA 1 319 177</p> 

			<p>a) </p> <p>b) </p>	<p>K: </p> <p>N: </p>	
<p>206.954 70HM 6571A3B 1 490 525 ACM 8x</p> 	<p>646.540 92HM 9448AA 6 909 665 3x</p>  <p>646.550 92HM 9448BA 6 909 666 1x</p> 	<p>825.639 91HM 9441AB 6 763 409</p>  	<p>a) 193.713 92HM 6013AA 5 027 042</p>  <p>b) 786.500 928M 6734AA 1 454 118 Nylon A 14,5x22x2</p>	<p>K:← 757.497 86HM 6700AA 1 669 254 ASW RD FPM 42x56x7</p> <p>K:→ 550.680 1 032 209 ASW LD PTFE/FPM 79,33x95,28x11</p> <p>K:→ 763.713 86HM 6701A1A 1 641 893 AW/BS LD FPM 79,33x95,25x11</p> <p>N:← 757.497 86HM 6700AA 1 669 254 ASW RD FPM 42x56x7</p>	
<p>VAS 398.450 026.670 96MM 6571BG 1 148 123 FPM 8x</p> <p>026.700 96MM 6571AG 1 148 124 FPM 8x</p>	<p>377.811 2S6G 9448DA 1 326 381</p> 	<p>537.630 4M5G 9441FA 1 338 179 4x</p> 	<p>a) 036.164 Dirko HT / EU</p> <p>a) 510.031 Dirko HT / USA/CDN/MEX</p> <p>a) 527.291 Dirko HT / RU</p> <p>a) 648.661 Dirko HT / BR</p> <p>b) 012.001 97JM 6730BA 1 013 938 M 14x1,5x20</p> <p>b) 176.090 97JM 6734BA 1 005 593 13x22,4x3</p>	<p>K:← 023.590 YS6G 6700AA 1 112 945 ASW RD FPM 33x47x5</p> <p>K:→ 023.862 1S4G-6K301AB 1 211 161 SP LD PTFE 80</p> <p>N:← 542.030 4M5G 6K292CB 1 319 178 ASW RD FPM 46x56,4x7 2x</p>	

FORD

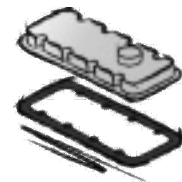
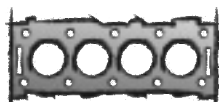
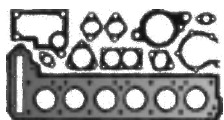

FYDA **FYDB**
FYDC **FYDD**
FYDH

4 Cyl. **1596 ccm**
Cyl. 79,0 Ø

Courier

08/2001 → 12/2011

Focus

10/1998 → 06/2007

ES⊕ **434.300**
→09/2002



ES⊕ **434.320**
10/2002→
→09/2003



ES* **196.150**
10/2003→

CS* **196.140**



013.920

YS4G 6051CA

1 097 083

0,50 mm $\frac{\pm}{\pm}$ 80 Ø

→09/2002



125.042

3S4G 6051CA

1 253 985

0,32 mm $\frac{\pm}{\pm}$ 80 Ø

10/2002→

→09/2003

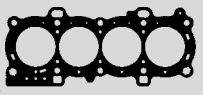

255.050

4M5G 6051CA

1 305 949

0,32 mm $\frac{\pm}{\pm}$ 80 Ø

10/2003→

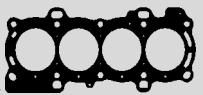

ZKS **087.830**

1 765 604 (10x)

M 10x1,5x143

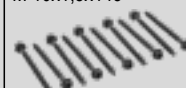

389.110

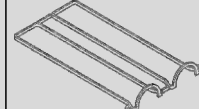

761.031

1S6G 6K260AA

1 141 575



FYJA
FYJC

FYJB

4 Cyl. **1596 ccm**
Cyl. 79,0 Ø

Fiesta

11/2001 → 06/2008

Fusion

08/2002 → 11/2009

ES⊕ **569.650**
→11/2003



ES⊕ **569.871**
12/2003→



CS* **389.050**



013.920

YS4G 6051CA

1 097 083

0,50 mm $\frac{\pm}{\pm}$ 80 Ø

→12/2002



125.042

3S4G 6051CA

1 253 985

0,32 mm $\frac{\pm}{\pm}$ 80 Ø

12/2002→

→09/2003

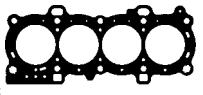

255.050

4M5G 6051CA

1 305 949

0,32 mm $\frac{\pm}{\pm}$ 80 Ø

09/2003→

→10/2008

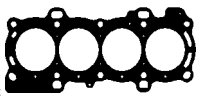

287.560

7S7G 6051CB

1 471 525

0,32 mm $\frac{\pm}{\pm}$ 79,8 Ø

11/2008→

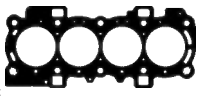

ZKS **087.830**

1 765 604 (10x)

M 10x1,5x143



389.110

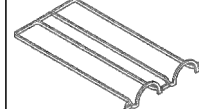















761.031

1S6G 6K260AA

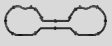
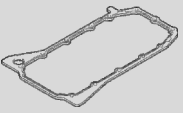
1 141 575



			<p>a) </p> <p>b) </p>	<p>K: </p> <p>N: </p>	
<p>VAS 398.450 026.700 96MM 6571AG 1 148 124 FPM E 8x 026.670 96MM 6571BG 1 148 123 FPM A 8x</p>	<p>864.221 98MM 9448AB 1 072 066 →11/2003  377.811 2S6G 9448DA 1 326 381 11/2003→ </p>	<p>377.170 98MM 9441AA 1 072 063 2x </p>	<p>a) 025.450 96MM 6710AD 1 004 459 →11/1999 </p> <p>a) 036.164 Dirko HT / EU 12/1999→</p> <p>a) 510.031 Dirko HT / USA/CDN/MEX 12/1999→</p> <p>a) 527.291 Dirko HT / RU 12/1999→</p> <p>a) 648.661 Dirko HT / BR 12/1999→</p> <p>b) 012.001 97JM 6730BA 1 013 938 M 14x1,5x20</p> <p>b) 176.090 97JM 6734BA 1 005 593 13x22,4x3</p>	<p>K:← 023.590 YS6G 6700AA 1 112 945 ASW RD FPM 33x47x5 K:→ 023.862 1S4G-6K301AB 1 211 161 SP LD PTFE 80 N:← 023.520 6M5G 6K292BA 1 471 482 ASW RD FPM 38x52x6 2x</p>	
<p>VAS 398.450 026.700 96MM 6571AG 1 148 124 FPM E 8x 026.670 96MM 6571BG 1 148 123 FPM A 8x</p>	<p>024.940 97MF 9448AA 1 031 021 →11/2003  377.811 2S6G 9448DA 1 326 381 12/2003→ </p>	<p>025.260 2S6G 9441CA 1 142 502 4x </p>	<p>a) 036.164 Dirko HT / EU</p> <p>a) 510.031 Dirko HT / USA/CDN/MEX</p> <p>a) 527.291 Dirko HT / RU</p> <p>a) 648.661 Dirko HT / BR</p> <p>b) 012.001 97JM 6730BA 1 013 938 M 14x1,5x20</p> <p>b) 176.090 97JM 6734BA 1 005 593 13x22,4x3</p>	<p>K:← 023.590 YS6G 6700AA 1 112 945 ASW RD FPM 33x47x5 K:→ 023.862 1S4G-6K301AB 1 211 161 SP LD PTFE 80 N:← 023.520 6M5G 6K292BA 1 471 482 ASW RD FPM 38x52x6 2x</p>	

FORD

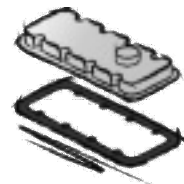
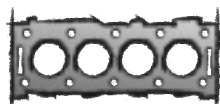
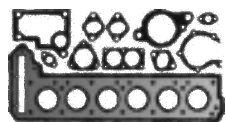

HWDA HWDB
SHDA SHDB
SHDC

4 Cyl. **1596 ccm**
Cyl. 79,0 Ø

C-Max
02/2007 → 09/2010
Focus
07/2004 → 09/2012
Focus C-Max
10/2003 → 03/2007

ES⊕ **569.871**



CS* **389.050**



255.050
4M5G 6051CA
1 305 949
0,32 mm $\frac{3}{4}$ 80 Ø
→02/2007

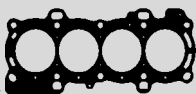

287.560
7S7G 6051CB
1 471 525
0,32 mm $\frac{3}{4}$ 79,8 Ø
03/2007→

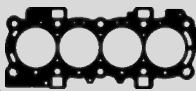

ZKS 087.830
1 765 604 (10x)
M 10x1,5x143



761.031
1S6G 6K260AA
1 141 575

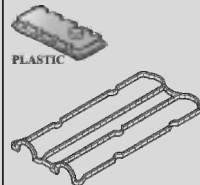

JQDA JQDB
JQGA JQMA
JQMB JTBA
JTBB JTDA
JTDB JTJA
JTJB JTJC
JTMA JTWA
JTWB YUDA

4 Cyl. **1596 ccm**
Cyl. 79,0 Ø

C-Max
12/2010 → 06/2019
Fiesta
03/2013 →
Focus
07/2010 →
Galaxy
11/2010 → 06/2015
Grand C-Max
12/2010 → 06/2019
Kuga
10/2012 →
Mondeo
11/2010 → 01/2015
S-Max
02/2011 → 12/2014
Tourneo Connect
11/2013 →
Transit Connect
09/2013 →

ES⊕ **389.980**

346.520
BM5G 6051AC
1 685 734
0,50 mm $\frac{3}{4}$ 79,7 Ø















486.470
BM5G-6051-AD
1 849 263
0,50 mm $\frac{3}{4}$ 80 Ø

ZKS 087.830
1 765 604 (10x)
M 10x1,5x143



318.170
BM5G 6584BA
1 704 081
(BM5G-6M293DE/DF)
(BM5G-6M293DB/DC)



			<p>a) </p> <p>b) </p>	<p>K: </p> <p>N: </p>	
<p>VAS 398.450 026.700 96MM 6571AG 1 148 124 FPM E 8x</p> <p>026.670 96MM 6571BG 1 148 123 FPM A 8x</p>	<p>377.811 2S6G 9448DA 1 326 381</p> 	<p>025.260 2S6G 9441CA 1 142 502 4x</p> 	<p>a) 036.164 Dirko HT / EU</p> <p>a) 510.031 Dirko HT / USA/CDN/MEX</p> <p>a) 527.291 Dirko HT / RU</p> <p>a) 648.661 Dirko HT / BR</p> <p>b) 012.001 97JM 6730BA 1 013 938 M 14x1,5x20</p> <p>b) 176.090 97JM 6734BA 1 005 593 13x22,4x3</p>	<p>K:← 023.590 YS6G 6700AA 1 112 945 ASW RD FPM 33x47x5</p> <p>K:→ 023.862 1S4G-6K301AB 1 211 161 SP LD PTFE 80</p> <p>N:← 023.520 6M5G 6K292BA 1 471 482 ASW RD FPM 38x52x6 2x</p>	
<p>317.020 BM5G-6571-CA 1 791 865 FPM 16x</p>	<p>346.510 BM5G-9448BA 1 850 924</p> 	<p>315.260 BM5G-9441BA 1 685 610</p> 	<p>a) 036.164 Dirko HT / EU</p> <p>a) 510.031 Dirko HT / USA/CDN/MEX</p> <p>a) 527.291 Dirko HT / RU</p> <p>a) 648.661 Dirko HT / BR</p> <p>b) 012.001 97JM 6730BA 1 013 938 M 14x1,5x20</p> <p>b) 176.090 97JM 6734BA 1 005 593 13x22,4x3</p>	<p>K:← 023.590 YS6G 6700AA 1 112 945 ASW RD FPM 33x47x5</p> <p>K:→ 023.862 1S4G-6K301AB 1 211 161 SP LD PTFE 80</p> <p>N:← 542.030 4M5G 6K292CB 1 319 178 ASW RD FPM 46x56,4x7 2x</p>	<p>TLS 541.510</p>

FORD

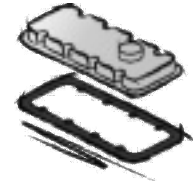
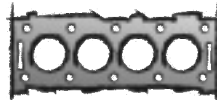
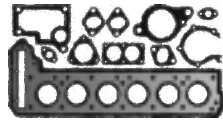

L1T L1V
L1W
 4 Cyl. **1596 ccm**
 Cyl. 79,0 Ø

Fiesta
 02/1999 → 09/2002
Puma
 08/2000 → 06/2002

ES⊕ **434.300**

 CS* **196.140**



013.920
 YS4G 6051CA
 1 097 083
 0,50 mm $\frac{1}{4}$ 80 Ø



ZKS 087.830
 1 765 604 (10x)
 M 10x1,5x143

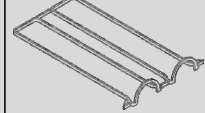

389.110
 AL



761.031
 1S6G 6K260AA
 1 141 575

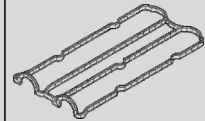

HXJA HXJB
HXJD HXJE
IQDA IQDB
IQJB IQJC
IQJE KGBA
MUDA MUDD
PNBA PNDA
PNDD RHBA
U5JA XTDA

4 Cyl. **1596 ccm**
 Cyl. 79,0 Ø

B-Max
 10/2012 →
C-Max
 10/2010 → 06/2019
Ecosport
 08/2012 →
Fiesta
 06/2008 →
Focus
 07/2010 →
Grand C-Max
 12/2010 → 06/2019
Mondeo
 03/2007 → 01/2015

ES⊕ **226.400**
 CS* **539.410**

362.832
 7S7G 6051XB
 1 471 557
 0,32 mm $\frac{1}{8}$ 79,8 Ø

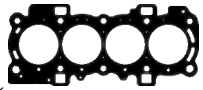







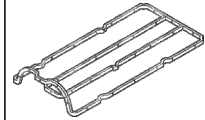



ZKS 087.830
 1 765 604 (10x)
 M 10x1,5x143



010.051
 4M5G 6K260CA
 1 319 177

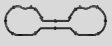

			<p>a) </p> <p>b) </p>	<p>K: </p> <p>N: </p>	
<p>VAS 398.450 026.700 96MM 6571AG 1 148 124 FPM E 8x</p> <p>026.670 96MM 6571BG 1 148 123 FPM A 8x</p>	<p>864.221 98MM 9448AB 1 072 066</p> 	<p>377.170 98MM 9441AA 1 072 063 2x</p> 	<p>a) 036.164 Dirko HT / EU</p> <p>a) 510.031 Dirko HT / USA/CDN/MEX</p> <p>a) 527.291 Dirko HT / RU</p> <p>a) 648.661 Dirko HT / BR</p> <p>b) 012.001 97JM 6730BA 1 013 938 M 14x1,5x20</p> <p>b) 176.090 97JM 6734BA 1 005 593 13x22,4x3</p>	<p>K:← 023.590 YS6G 6700AA 1 112 945 ASW RD FPM 33x47x5</p> <p>K:→ 023.862 1S4G-6K301AB 1 211 161 SP LD PTFE 80</p> <p>N:← 023.520 6M5G 6K292BA 1 471 482 ASW RD FPM 38x52x6 2x</p>	
<p>VAS 398.450 026.700 96MM 6571AG 1 148 124 FPM E 8x</p> <p>026.670 96MM 6571BG 1 148 123 FPM A 8x</p>	<p>377.811 2S6G 9448DA 1 326 381</p> 	<p>537.630 4M5G 9441FA 1 338 179 4x</p> 	<p>a) 036.164 Dirko HT / EU</p> <p>a) 510.031 Dirko HT / USA/CDN/MEX</p> <p>a) 527.291 Dirko HT / RU</p> <p>a) 648.661 Dirko HT / BR</p> <p>b) 012.001 97JM 6730BA 1 013 938 M 14x1,5x20</p> <p>b) 176.090 97JM 6734BA 1 005 593 13x22,4x3</p>	<p>K:← 023.590 YS6G 6700AA 1 112 945 ASW RD FPM 33x47x5</p> <p>K:→ 023.862 1S4G-6K301AB 1 211 161 SP LD PTFE 80</p> <p>N:← 542.030 4M5G 6K292CB 1 319 178 ASW RD FPM 46x56,4x7 2x</p>	

FORD

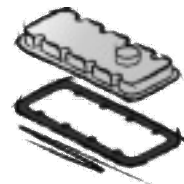
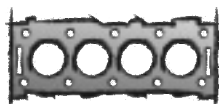
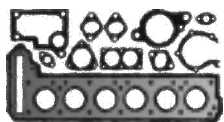

L1F
L1J

4 Cyl. **1597 ccm**
Cyl. 76,0 Ø

Mondeo
02/1993 → 09/2000

ES⊕ **458.521**
938X 6014BA
5 028 415
+938M 6051AA
+6 847 749

CS* **458.600**
938X 6013AB
5 031 032

646.631
938M 6051AA
6 847 749

77,5 Ø



ZKS 802.870
1 024 355 (10x)
M 10x1,5x102

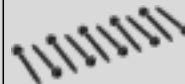

ZKHS 389.070
→05/1998



ZKHS 569.460
06/1998 →
→04/1999



ZKHS 389.060
05/1999 →



458.660
928M 6584C1B
1 663 394
→05/1998

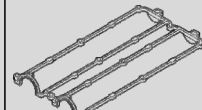

377.160
988M 6584AE
1 061 468
06/1998 →
→04/1999

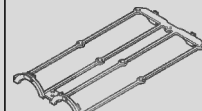











364.381
XS7G 6584AC
1 126 120
05/1999 →



198.240
6 759 630
9x14x5
10x

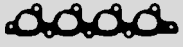

			<p>a) </p> <p>b) </p>	<p>K: </p> <p>N: </p>	
<p>VAS 214.540 127.490 958M 6571BD 1 086 432 FPM 8x</p> <p>127.510 958M 6571CC 1 086 431 FPM 8x</p>	<p>446.481 958M 9448AA 1 044 867</p> 	<p>832.245 938M 9441DC 6 780 895</p> 	<p>a) 467.830 938M 6710AC 7 008 824</p>  <p>b) 786.500 928M 6734AA 1 454 118 Nylon A 14,5x22x2</p>	<p>K:← 374.680 988M 6700A5B 1 102 415 ASW RD PTFE/ACM 35x50x7</p> <p>K:← 757.292 928M 6700B5A 6 165 500 ASW RD FPM 35x50x7</p> <p>K:→ 374.590 1M5G 6A321A5A 1 220 978 ASW LD PTFE/ACM 88x108x10</p> <p>K:→ 750.476 928M 6701B5A 6 126 179 ASW LD FPM 88x108x11</p> <p>N:← 467.860 928M 6K292B5B 1 067 029 AS OF RD FPM 42x53x7 2x</p>	

FORD

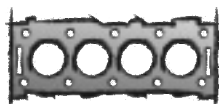
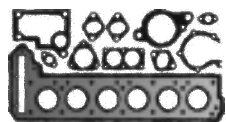

L1E L1G
L1H L1K
4 Cyl. **1597 ccm**
Cyl. 76,0 Ø

Escort
09/1992 → 08/2002
Fiesta
01/1994 → 12/1995
Orion
07/1992 → 12/1993

ES⊕ **458.441**
938X 6014AA
5 028 414
CS* **458.600**
938X 6013AB
5 031 032

646.631
938M 6051AA
6 847 749
77,5 Ø



ZKS **802.870**
1 024 355 (10x)
M 10x1,5x102

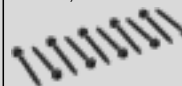

ZKHS **389.070**



458.660
928M 6584C1B
1 663 394

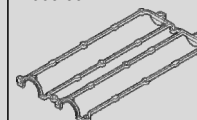

198.240
6 759 630
9x14x5
10x



L1L L1N
L1Q
4 Cyl. **1597 ccm**
Cyl. 76,0 Ø

Mondeo
05/1998 → 09/2000

476.200 ●
988M 6051AC
1 053 829
1,00 mm $\frac{3}{4}$
→01/1999



520.830
1 308 310
0,64 mm $\frac{3}{4}$ 77 Ø
02/1999 →



ZKS **802.870**
1 024 355 (10x)
M 10x1,5x102

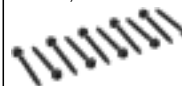

ZKHS **569.460**
→04/1999



ZKHS **389.060**
05/1999 →



377.160
988M 6584AE
1 061 468
→04/1999

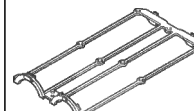















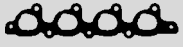

364.381
XS7G 6584AC
1 126 120
04/1999 →



198.240
6 759 630
9x14x5
10x



			<p>a) </p> <p>b) </p>	<p>K: </p> <p>N: </p>	
<p>VAS 214.540 127.490 958M 6571BD 1 086 432 FPM 8x</p> <p>127.510 958M 6571CC 1 086 431 FPM 8x</p>	<p>446.481 958M 9448AA 1 044 867</p> 	<p>446.461 928F-9441DB 1 663 389</p>  <p>829.473 928M 9441GB 6 669 767</p>	<p>a) 467.830 938M 6710AC 7 008 824</p>  <p>b) 786.500 928M 6734AA 1 454 118 Nylon A 14,5x22x2</p>	<p>K:← 374.680 988M 6700A5B 1 102 415 ASW RD PTFE/ACM 35x50x7</p> <p>K:← 757.292 928M 6700B5A 6 165 500 ASW RD FPM 35x50x7</p> <p>K:→ 374.590 1M5G 6A321A5A 1 220 978 ASW LD PTFE/ACM 88x108x10</p> <p>K:→ 750.476 928M 6701B5A 6 126 179 ASW LD FPM 88x108x11</p> <p>N:← 467.860 928M 6K292B5B 1 067 029 AS OF RD FPM 42x53x7 2x</p>	
<p>VAS 214.540 127.490 958M 6571BD 1 086 432 FPM 8x</p> <p>127.510 958M 6571CC 1 086 431 FPM 8x</p>	<p>446.481 958M 9448AA 1 044 867 →01/1999</p>  <p>439.101 988M 9448AA 1 078 966 02/1999→</p> 	<p>476.551 988M 9461AA 1 048 093 →09/1999 4x</p>  <p>364.071 XS7G 9461BA 1 090 949 10/1999→ 4x</p> 	<p>a) 036.164 Dirko HT / EU</p> <p>a) 510.031 Dirko HT / USA/CDN/MEX</p> <p>a) 527.291 Dirko HT / RU</p> <p>a) 648.661 Dirko HT / BR</p> <p>a) 388.160 988M 6710AG 1 078 707 ↑</p>  <p>b) 012.001 97JM 6730BA 1 013 938 M 14x1,5x20</p> <p>b) 176.090 97JM 6734BA 1 005 593 13x22,4x3</p>	<p>K:← 374.680 988M 6700A5B 1 102 415 ASW RD PTFE/ACM 35x50x7</p> <p>K:← 757.292 928M 6700B5A 6 165 500 ASW RD FPM 35x50x7</p> <p>K:→ 374.590 1M5G 6A321A5A 1 220 978 ASW LD PTFE/ACM 88x108x10</p> <p>K:→ 750.476 928M 6701B5A 6 126 179 ASW LD FPM 88x108x11</p> <p>N:← 467.860 928M 6K292B5B 1 067 029 AS OF RD FPM 42x53x7 2x</p>	

FORD

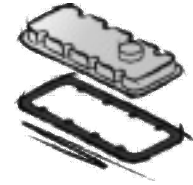
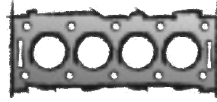
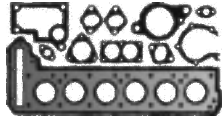

L4B LR2
4 Cyl. **1597 ccm**
Cyl. 80,0 Ø

Escort
07/1985 → 07/1990
Orion
03/1986 → 07/1990

ES⊕ **768.716**
93SX 6014BB
1 008 725
+86SM 6051A3C
+6 772 502
→08/1989

ES⊕ **768.694**
93SX 6014BB
86SX 6014BA
5 016 206
1 008 725
08/1989→

CS* **762.874**
93SX 6013BA
5 028 484

814.262
92SM 6051BA
6 772 502
1,70 mm ± 83 Ø



ZKS **820.490**
6 088 344 (10x)
M 10x1,5x135



764.221
88SM 6584AA
1 651 775



L6B
4 Cyl. **1597 ccm**
Cyl. 80,0 Ø

Sierra
10/1989 → 02/1993

ES⊕ **768.694**
93SX 6014BB
86SX 6014BA
5 016 206
1 008 725

CS* **762.874**
93SX 6013BA
5 028 484

814.262
92SM 6051BA
6 772 502
1,70 mm ± 83 Ø

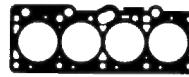

ZKS **820.490**
6 088 344 (10x)
M 10x1,5x135



764.221
88SM 6584AA
1 651 775



LJA LJB
LJC LJD
LJE LJF
4 Cyl. **1597 ccm**
Cyl. 80,0 Ø

Escort
08/1989 → 08/1993
Fiesta
03/1989 → 01/1994
Orion
02/1986 → 09/1992

ES⊕ **447.160**
93SX 6014EB
1 008 739
+86SM 6051A3C
+6 772 502

CS* **762.874**
93SX 6013BA
5 028 484

814.262
92SM 6051BA
6 772 502
1,70 mm ± 83 Ø

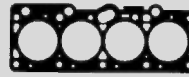













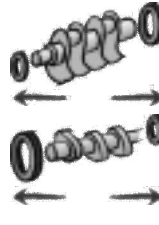

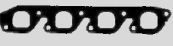



ZKS **820.490**
6 088 344 (10x)
M 10x1,5x135



764.221
88SM 6584AA
1 651 775

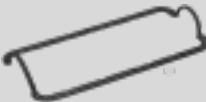

			<p>a) </p> <p>b) </p>	<p>K: </p> <p>N: </p>	
<p>405.990 81SM 6571A2F 6 674 302 FPM 8x</p>	<p>318.974 91SM 9448BB 6 591 017 →08/1989</p>  <p>705.811 91SM 9448AB 6 591 016 08/1989→</p> 	<p>318.968 92SM 9441AA 6 851 355</p> 	<p>a) OWS 388.940 6 166 108 +1 454 118</p>  <p>a) 587.486 88SM 6710AA 6 166 108</p>  <p>b) 786.500 928M 6734AA 1 454 118 Nylon A 14,5x22x2</p>	<p>K:← 757.292 928M 6700B5A 6 165 500 ASW RD FPM 35x50x7</p> <p>K:→ 750.476 928M 6701B5A 6 126 179 ASW LD FPM 88x108x11</p> <p>N:← 757.497 86HM 6700AA 1 669 254 ASW RD FPM 42x56x7</p>	
<p>405.990 81SM 6571A2F 6 674 302 FPM 8x</p>	<p>705.811 91SM 9448AB 6 591 016</p> 	<p>318.968 92SM 9441AA 6 851 355</p> 	<p>a) OWS 388.940 6 166 108 +1 454 118</p>  <p>a) 587.486 88SM 6710AA 6 166 108</p>  <p>b) 786.500 928M 6734AA 1 454 118 Nylon A 14,5x22x2</p>	<p>K:← 757.292 928M 6700B5A 6 165 500 ASW RD FPM 35x50x7</p> <p>K:→ 750.476 928M 6701B5A 6 126 179 ASW LD FPM 88x108x11</p> <p>N:← 757.497 86HM 6700AA 1 669 254 ASW RD FPM 42x56x7</p>	
<p>405.990 81SM 6571A2F 6 674 302 FPM 8x</p>	<p>318.974 91SM 9448BB 6 591 017</p> 	<p>446.340 91SM 9448BB 6 188 592</p> 	<p>a) OWS 388.940 6 166 108 +1 454 118</p>  <p>a) 587.486 88SM 6710AA 6 166 108</p>  <p>b) 786.500 928M 6734AA 1 454 118 Nylon A 14,5x22x2</p>	<p>K:← 757.292 928M 6700B5A 6 165 500 ASW RD FPM 35x50x7</p> <p>K:→ 750.476 928M 6701B5A 6 126 179 ASW LD FPM 88x108x11</p> <p>N:← 757.497 86HM 6700AA 1 669 254 ASW RD FPM 42x56x7</p>	

FORD

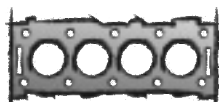
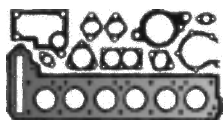

LP1 LP2
LP3 LPA
LUA LUAE
LUB LUC
LUD LUG

4 Cyl. **1597 ccm**
Cyl. 80,0 Ø

Escort
09/1980 → 07/1990
Fiesta
03/1984 → 11/1989
Orion
07/1983 → 07/1990

ES⊕ **325.121**
93SX 6014BA
1 008 718
+86SM 6051A3C
+6 772 502
CS* **762.874**
93SX 6013BA
5 028 484
04/1985→

814.262
92SM 6051BA
6 772 502
1,70 mm ± 83 Ø



ZKS **820.490**
6 088 344 (10x)
M 10x1,5x135



764.221
88SM 6584AA
1 651 775



LR1
LRA

4 Cyl. **1597 ccm**
Cyl. 80,0 Ø

Escort
10/1982 → 12/1985
Orion
07/1983 → 03/1986

ES⊕ **768.716**
93SX 6014BB
1 008 725
+86SM 6051A3C
+6 772 502
CS* **762.874**
93SX 6013BA
5 028 484
04/1985→

814.262
92SM 6051BA
6 772 502
1,70 mm ± 83 Ø



ZKS **820.490**
6 088 344 (10x)
M 10x1,5x135



764.221
88SM 6584AA
1 651 775



LSD LSDA
LSE LSF

4 Cyl. **1597 ccm**
Cyl. 81,3 Ø

Sierra
08/1982 → 02/1993

ES⊕ **590.615**
93HX 6014AB
5 028 468
+92HM 6051BA
+6 905 862
CS* **424.930**
93HX 6013AA
5 028 466

896.748 ●
92HM 6051BA
6 905 862
83,2 Ø





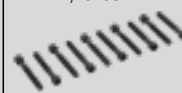



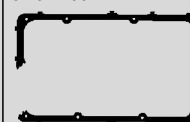

























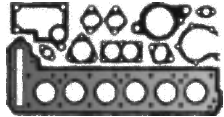
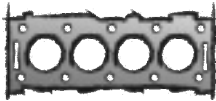

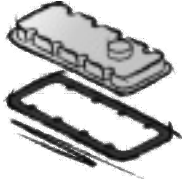



ZKS **802.860**
6 157 105 (10x)
M 12x1,75x95



















764.248
85HM 6584BB
6 491 460



			<p>a) </p> <p>b) </p>	<p>K: </p> <p>N: </p>	
<p>405.990 81SM 6571A2F 6 674 302 FPM 8x</p>	<p>318.974 91SM 9448BB 6 591 017</p> 	<p>318.968 92SM 9441AA 6 851 355</p> 	<p>a) OWS 388.940 6 166 108 +1 454 118</p>  <p>a) 587.486 88SM 6710AA 6 166 108</p>  <p>b) 786.500 928M 6734AA 1 454 118 Nylon A 14,5x22x2</p>	<p>K:← 757.292 928M 6700B5A 6 165 500 ASW RD FPM 35x50x7</p> <p>K:→ 750.476 928M 6701B5A 6 126 179 ASW LD FPM 88x108x11</p> <p>N:← 757.497 86HM 6700AA 1 669 254 ASW RD FPM 42x56x7</p>	
<p>405.990 81SM 6571A2F 6 674 302 FPM 8x</p>	<p>318.974 91SM 9448BB 6 591 017</p> 	<p>318.968 92SM 9441AA 6 851 355</p>  <p>522.407 V96SX 9441CA 1 023 229</p> 	<p>a) OWS 388.940 6 166 108 +1 454 118 04/1985→</p>  <p>a) 587.486 88SM 6710AA 6 166 108 04/1985→</p>  <p>b) 786.500 928M 6734AA 1 454 118 Nylon A 14,5x22x2</p>	<p>K:← 757.292 928M 6700B5A 6 165 500 ASW RD FPM 35x50x7</p> <p>K:→ 750.476 928M 6701B5A 6 126 179 ASW LD FPM 88x108x11</p> <p>N:← 757.497 86HM 6700AA 1 669 254 ASW RD FPM 42x56x7</p>	
<p>206.954 70HM 6571A3B 1 490 525 ACM 8x</p> 	<p>646.540 92HM 9448AA 6 909 665 3x</p>  <p>646.550 92HM 9448BA 6 909 666 1x</p> 	<p>825.639 91HM 9441AB 6 763 409</p> 	<p>a) 193.713 92HM 6013AA 5 027 042</p>  <p>b) 786.500 928M 6734AA 1 454 118 Nylon A 14,5x22x2</p>	<p>K:← 757.497 86HM 6700AA 1 669 254 ASW RD FPM 42x56x7</p> <p>K:→ 550.680 1 032 209 ASW LD PTFE/FPM 79,33x95,28x11</p> <p>K:→ 763.713 86HM 6701A1A 1 641 893 AW/BS LD FPM 79,33x95,25x11</p> <p>N:← 757.497 86HM 6700AA 1 669 254 ASW RD FPM 42x56x7</p>	

<p>FORD</p> 				
<p>LUH LUJ LUK</p> <p>4 Cyl. 1597 ccm Cyl. 80,0 Ø</p> <p>Escort 07/1990 → 08/1992</p> <p>Fiesta 01/1989 → 01/1994</p> <p>Orion 07/1990 → 12/1992</p>	<p>ES⊕ 325.121 93SX 6014BA 1 008 718 +86SM 6051A3C +6 772 502</p> <p>CS* 762.874 93SX 6013BA 5 028 484</p>	<p>814.262 92SM 6051BA 6 772 502 1,70 mm \pm 83 Ø</p> 	<p>ZKS 820.490 6 088 344 (10x) M 10x1,5x135</p> 	<p>764.221 88SM 6584AA 1 651 775</p> 
<p>CCA CDC CDRB</p> <p>4 Cyl. 1599 ccm Cyl. 82,0 Ø</p> <p>Ka 02/2001 →</p> <p>Street Ka 05/2003 → 07/2005</p>	<p>ES⊕ 030.470 CS* 030.440</p>	<p>024.999 YS6G 6051A2B 1 099 084 0,65 mm \pm 83 Ø</p> 	<p>ZKS 156.550 1 385 727 (10x) M 11x1,5x158</p> 	<p>026.540 XS6E 6584AB 1 089 844</p> 
<p>LTA LTC</p> <p>4 Cyl. 1608 ccm Cyl. 80,0 Ø</p> <p>Escort 02/1984 → 07/1990</p> <p>Fiesta 09/1983 → 09/1989</p> <p>Orion 02/1984 → 01/1989</p>	<p>ES⊕ 573.486 5 011 844</p> 	<p>580.075 91FF 6051CAA 6 830 397 0,630 mm → 0,680 mm 1,47 mm \pm 81,3 Ø</p> <p>580.083 ● 91FF 6051CBA 6 830 398 0,690 mm → 0,740 mm 1,55 mm \pm 81,3 Ø</p>  	<p>ZKS 802.940 6 175 359 (10x) 7/16"x135</p> 	<p>ZKHS 557.668</p>  <p>558.141 84FM 6584AD 1 628 397</p>  <p>557.617 84FM 6K670AB 6 123 016 →</p>  <p>557.609 84FM 6A545AC 6 112 196 ←</p> 

			<p>a) </p> <p>b) </p>	<p>K: </p> <p>N: </p>	
<p>405.990 81SM 6571A2F 6 674 302 FPM 8x</p>	<p>318.974 91SM 9448BB 6 591 017</p> 	<p>318.968 92SM 9441AA 6 851 355</p> 	<p>a) OWS 388.940 6 166 108 +1 454 118</p>  <p>a) 587.486 88SM 6710AA 6 166 108</p>  <p>b) 786.500 928M 6734AA 1 454 118 Nylon A 14,5x22x2</p>	<p>K:← 757.292 928M 6700B5A 6 165 500 ASW RD FPM 35x50x7</p> <p>K:→ 750.476 928M 6701B5A 6 126 179 ASW LD FPM 88x108x11</p> <p>N:← 757.497 86HM 6700AA 1 669 254 ASW RD FPM 42x56x7</p>	
<p>026.640 XS6E 6571AB 1 313 567 FPM 8x</p>	<p>024.950 1 127 417</p> 	<p>025.250 XS6E 9441BA 1 089 772 2x</p> 	<p>a) 025.481 XS6E 6710A2B 1 089 838</p>  <p>b) 012.001 97JM 6730BA 1 013 938 M 14x1,5x20</p> <p>b) 176.090 97JM 6734BA 1 005 593 13x22,4x3</p>	<p>K:← 023.740 2S6G 6D316AA 1 219 337 ASW RD PTFE/ACM 40x62x7,4</p> <p>K:→ 023.950 2S6G 6A321BA 1 388 409 IWD LD PTFE 79,33x131,3x19</p>	
<p>562.645 84FM 6571CA 1 635 583 FPM 8x</p>	<p>557.863 84FM 9448AB 6 121 889</p> 	<p>557.856 84FM 9441AC 6 886 002</p> 	<p>b) 786.500 928M 6734AA 1 454 118 Nylon A 14,5x22x2</p>	<p>K:← 562.661 84FM 6700A1B 6 135 093 ASW RD FPM 42x58x11</p> <p>K:→ 550.680 1 032 209 ASW LD PTFE/FPM 79,33x95,28x11</p> <p>K:→ 763.713 86HM 6701A1A 1 641 893 AW/BS LD FPM 79,33x95,25x11</p> <p>N:← 562.653 84FM 6L270A1A 6 135 090 ASW RD FPM 28x38x7</p>	

FORD

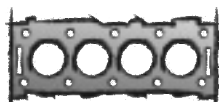
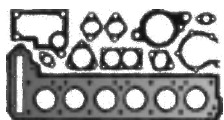

**BHDA
BHDB**

4 Cyl. 1753 ccm
Cyl. 82,5 Ø

Focus DI/TDDi

08/1999 → 03/2005

Focus TDDi

08/1999 → 03/2005

ES⊕ **030.492**



CS* **030.460**

027.062

1S4Q 6051GB
1 477 466



0,550 mm
→
0,600 mm

1,27 mm $\frac{\pm}{\pm}$

2 ⊗

027.072

1S4Q 6051HB
1 477 467



0,601 mm
→
0,650 mm

1,32 mm $\frac{\pm}{\pm}$

3 ⊗

027.082

1S4Q 6051JB
1 477 470



0,651 mm
→
0,700 mm

1,37 mm $\frac{\pm}{\pm}$

4 ⊗

027.092

1S4Q 6051KB
1 477 472



0,701 mm
→
0,750 mm

1,42 mm $\frac{\pm}{\pm}$

5 ⊗

027.102

1S4Q 6051LB
1 477 473



0,751 mm
→
0,800 mm

1,47 mm $\frac{\pm}{\pm}$

6 ⊗

027.112

1S4Q 6051MB
1 477 474



0,801 mm
→
0,850 mm

1,52 mm $\frac{\pm}{\pm}$

7 ⊗

ZKS **027.850**

1 079 925 (2x)
+1 079 926 (8x)
M 12x1,5x137/177











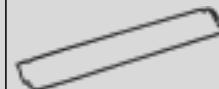





ZKHS **428.910**



027.570

XS4Q 6K260AB
1 078 524



			<p>a) </p> <p>b) </p>	<p>K: </p> <p>N: </p>	
<p>761.389 86TM 6571AB 1 644 647 FPM 8x</p>	<p>128.162 4M5Q 9448AA 1 352 847</p> 	<p>406.490 1S4Q 9441AA 1 113 080</p>  <p>944.110 Metal 1S4Q 9441AA 1 113 080</p> 	<p>a) 027.330 XS4Q 6710AE 1 078 498</p>  <p>a) 036.164 Dirko HT / EU</p> <p>a) 510.031 Dirko HT / USA/CDN/MEX</p> <p>a) 527.291 Dirko HT / RU</p> <p>a) 648.661 Dirko HT / BR</p> <p>b) 012.001 97JM 6730BA 1 013 938 M 14x1,5x20</p> <p>b) 176.090 97JM 6734BA 1 005 593 13x22,4x3</p>	<p>K:← 026.770 XS4Q 6700AD 1 198 045 ASW RD PTFE/ACM 30x50x7,5</p> <p>K:→ 026.821 XS4Q 6K301AF 1 207 615 IWD LD PTFE 79,8x18,8</p> <p>N:← 562.653 84FM 6L270A1A 6 135 090 ASW RD FPM 28x38x7</p>	<p>TLS 733.870</p> 

FORD

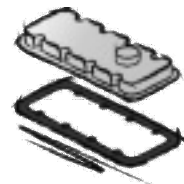
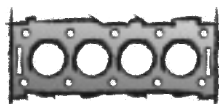
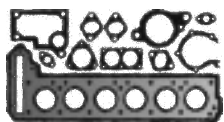

C9DA C9DB
C9DC FFDA

4 Cyl. 1753 ccm
Cyl. 82,5 Ø

Focus DI/TDDi
10/1998 → 11/2004

Focus TDCi
08/2002 → 03/2005

Focus TDDi
08/1998 → 03/2005

ES⊕ **030.492**



CS* **030.500**

027.062

1S4Q 6051GB
1 477 466



0,550 mm
→
0,600 mm

1,27 mm $\frac{1}{2}$

2 ⊗

027.072

1S4Q 6051HB
1 477 467



0,601 mm
→
0,650 mm

1,32 mm $\frac{1}{2}$

3 ⊗

027.082

1S4Q 6051JB
1 477 470



0,651 mm
→
0,700 mm

1,37 mm $\frac{1}{2}$

4 ⊗

027.092

1S4Q 6051KB
1 477 472



0,701 mm
→
0,750 mm

1,42 mm $\frac{1}{2}$

5 ⊗

027.102

1S4Q 6051LB
1 477 473



0,751 mm
→
0,800 mm

1,47 mm $\frac{1}{2}$

6 ⊗

027.112

1S4Q 6051MB
1 477 474



0,801 mm
→
0,850 mm

1,52 mm $\frac{1}{2}$

7 ⊗

ZKS **027.850**

1 079 925 (2x)
+1 079 926 (8x)
M 12x1,5x137/177











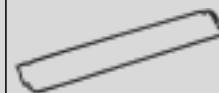





ZKHS **428.910**



027.570

XS4Q 6K260AB
1 078 524



			<p>a) </p> <p>b) </p>	<p>K: </p> <p>N: </p>	
<p>761.389 86TM 6571AB 1 644 647 FPM 8x</p>	<p>128.162 4M5Q 9448AA 1 352 847</p> 	<p>406.490 1S4Q 9441AA 1 113 080</p>  <p>944.110 Metal 1S4Q 9441AA 1 113 080</p> 	<p>a) 027.330 XS4Q 6710AE 1 078 498</p>  <p>a) 036.164 Dirko HT / EU</p> <p>a) 510.031 Dirko HT / USA/CDN/MEX</p> <p>a) 527.291 Dirko HT / RU</p> <p>a) 648.661 Dirko HT / BR</p> <p>b) 012.001 97JM 6730BA 1 013 938 M 14x1,5x20</p> <p>b) 176.090 97JM 6734BA 1 005 593 13x22,4x3</p>	<p>K:← 026.770 XS4Q 6700AD 1 198 045 ASW RD PTFE/ACM 30x50x7,5</p> <p>K:→ 026.821 XS4Q 6K301AF 1 207 615 IWD LD PTFE 79,8x18,8</p> <p>N:← 562.653 84FM 6L270A1A 6 135 090 ASW RD FPM 28x38x7</p>	<p>TLS 733.870</p> 

FORD

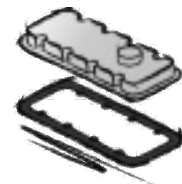
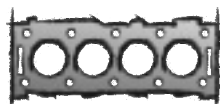
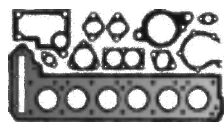

F9DA
F9DB
4 Cyl. **1753 ccm**
Cyl. 82,5 Ø

Focus TDCi
03/2001 → 03/2005

ES⊕ **030.521**



CS* **030.500**

027.062

1S4Q 6051GB
1 477 466



0,550 mm
→
0,600 mm

1,27 mm $\frac{\pm}{\pm}$
2 ⊗

027.072

1S4Q 6051HB
1 477 467



0,601 mm
→
0,650 mm

1,32 mm $\frac{\pm}{\pm}$
3 ⊗

027.082

1S4Q 6051JB
1 477 470



0,651 mm
→
0,700 mm

1,37 mm $\frac{\pm}{\pm}$
4 ⊗

027.092

1S4Q 6051KB
1 477 472



0,701 mm
→
0,750 mm

1,42 mm $\frac{\pm}{\pm}$
5 ⊗

027.102

1S4Q 6051LB
1 477 473



0,751 mm
→
0,800 mm

1,47 mm $\frac{\pm}{\pm}$
6 ⊗

027.112

1S4Q 6051MB
1 477 474



0,801 mm
→
0,850 mm

1,52 mm $\frac{\pm}{\pm}$
7 ⊗

ZKS **027.850**

1 079 925 (2x)
+1 079 926 (8x)
M 12x1,5x137/177











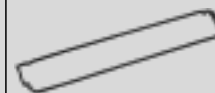





ZKHS **428.910**



027.570

XS4Q 6K260AB
1 078 524



			<p>a) </p> <p>b) </p>	<p>K: </p> <p>N: </p>	
<p>761.389 86TM 6571AB 1 644 647 FPM 8x</p>	<p>128.162 4M5Q 9448AA 1 352 847</p> 	<p>406.490 1S4Q 9441AA 1 113 080</p>  <p>944.110 Metal 1S4Q 9441AA 1 113 080</p> 	<p>a) 027.330 XS4Q 6710AE 1 078 498</p>  <p>a) 036.164 Dirko HT / EU</p> <p>a) 510.031 Dirko HT / USA/CDN/MEX</p> <p>a) 527.291 Dirko HT / RU</p> <p>a) 648.661 Dirko HT / BR</p> <p>b) 012.001 97JM 6730BA 1 013 938 M 14x1,5x20</p> <p>b) 176.090 97JM 6734BA 1 005 593 13x22,4x3</p>	<p>K:← 026.770 XS4Q 6700AD 1 198 045 ASW RD PTFE/ACM 30x50x7,5</p> <p>K:→ 026.821 XS4Q 6K301AF 1 207 615 IWD LD PTFE 79,8x18,8</p> <p>N:← 562.653 84FM 6L270A1A 6 135 090 ASW RD FPM 28x38x7</p>	<p>TLS 733.870</p> 

FORD

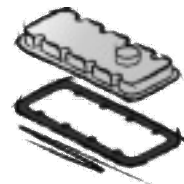
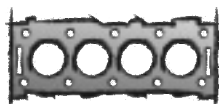
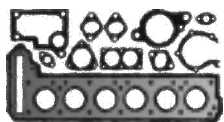

FFBA FFWA
KHBA KKDA
KKDB QYBA
QYWA

4 Cyl. 1753 ccm
Cyl. 82,5 Ø

C-Max TDCi

02/2007 → 09/2010

Focus C-Max TDCi

01/2005 → 03/2007

Focus TDCi

07/2004 → 09/2012

Galaxy TDCi

05/2006 → 06/2015

Mondeo TDCi

03/2007 → 01/2015

S-Max TDCi

05/2006 → 12/2014

ES⊕ **030.521**



CS* **030.500**

027.062

1S4Q 6051GB

1 477 466

0,550 mm
→
0,600 mm

1,27 mm ±

2 ⊗

027.072

1S4Q 6051HB

1 477 467

0,601 mm
→
0,650 mm

1,32 mm ±

3 ⊗

027.082

1S4Q 6051JB

1 477 470

0,651 mm
→
0,700 mm

1,37 mm ±

4 ⊗

027.092

1S4Q 6051KB

1 477 472

0,701 mm
→
0,750 mm

1,42 mm ±

5 ⊗

027.102

1S4Q 6051LB

1 477 473

0,751 mm
→
0,800 mm

1,47 mm ±

6 ⊗

027.112

1S4Q 6051MB

1 477 474

0,801 mm
→
0,850 mm

1,52 mm ±

7 ⊗

ZKS **027.850**

1 079 925 (2x)

+1 079 926 (8x)

M 12x1,5x137/177



ZKHS **428.910**









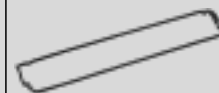





027.570

XS4Q 6K260AB

1 078 524



			<p>a) </p> <p>b) </p>	<p>K: </p> <p>N: </p>	
<p>761.389 86TM 6571AB 1 644 647 FPM 8x</p>	<p>128.162 4M5Q 9448AA 1 352 847</p> 	<p>406.490 1S4Q 9441AA 1 113 080</p>  <p>944.110 Metal 1S4Q 9441AA 1 113 080</p> 	<p>a) 027.330 XS4Q 6710AE 1 078 498</p>  <p>a) 036.164 Dirko HT / EU</p> <p>a) 510.031 Dirko HT / USA/CDN/MEX</p> <p>a) 527.291 Dirko HT / RU</p> <p>a) 648.661 Dirko HT / BR</p> <p>b) 012.001 97JM 6730BA 1 013 938 M 14x1,5x20</p> <p>b) 176.090 97JM 6734BA 1 005 593 13x22,4x3</p>	<p>K:← 026.770 XS4Q 6700AD 1 198 045 ASW RD PTFE/ACM 30x50x7,5</p> <p>K:→ 026.821 XS4Q 6K301AF 1 207 615 IWD LD PTFE 79,8x18,8</p> <p>N:← 562.653 84FM 6L270A1A 6 135 090 ASW RD FPM 28x38x7</p>	<p>TLS 551.410</p> 

FORD

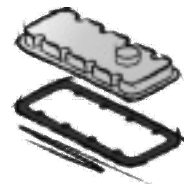
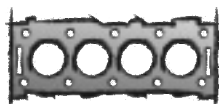
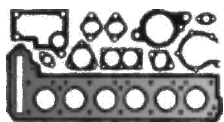

BHPA **HCPA**
HCPB **HCPC**
HCPD **P7PA**
P7PB **P9PA**
P9PB **P9PC**
P9PD **R2PA**
R3PA **RWPA**
RWPB **RWPC**
RWPD **RWPE**
RWPF

4 Cyl. 1753 ccm
Cyl. 82,5 Ø

Tourneo Connect TDCi

06/2002 → 12/2013

Transit Connect DI

06/2002 → 12/2013

Transit Connect TDCi

06/2002 → 12/2013

ES⊕ **030.531**



CS* **030.500**

027.062

1S4Q 6051GB
1 477 466



0,550 mm
 →
 0,600 mm

1,27 mm ±

2 ⊗

027.072

1S4Q 6051HB
1 477 467



0,601 mm
 →
 0,650 mm

1,32 mm ±

3 ⊗

027.082

1S4Q 6051JB
1 477 470



0,651 mm
 →
 0,700 mm

1,37 mm ±

4 ⊗

027.092

1S4Q 6051KB
1 477 472



0,701 mm
 →
 0,750 mm

1,42 mm ±

5 ⊗

027.102

1S4Q 6051LB
1 477 473



0,751 mm
 →
 0,800 mm

1,47 mm ±

6 ⊗

027.112

1S4Q 6051MB
1 477 474



0,801 mm
 →
 0,850 mm

1,52 mm ±

7 ⊗

ZKS **027.850**

1 079 925 (2x)
+1 079 926 (8x)
M 12x1,5x137/177











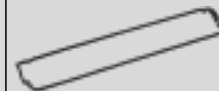





ZKHS **428.910**



027.570

XS4Q 6K260AB
1 078 524



			<p>a) </p> <p>b) </p>	<p>K: </p> <p>N: </p>	
<p>761.389 86TM 6571AB 1 644 647 FPM 8x</p>	<p>128.162 4M5Q 9448AA 1 352 847</p> 	<p>406.490 1S4Q 9441AA 1 113 080</p>  <p>944.110 Metal 1S4Q 9441AA 1 113 080</p> 	<p>a) 027.330 XS4Q 6710AE 1 078 498</p>  <p>a) 036.164 Dirko HT / EU</p> <p>a) 510.031 Dirko HT / USA/CDN/MEX</p> <p>a) 527.291 Dirko HT / RU</p> <p>a) 648.661 Dirko HT / BR</p> <p>b) 012.001 97JM 6730BA 1 013 938 M 14x1,5x20</p> <p>b) 176.090 97JM 6734BA 1 005 593 13x22,4x3</p>	<p>K:← 026.770 XS4Q 6700AD 1 198 045 ASW RD PTFE/ACM 30x50x7,5</p> <p>K:→ 026.821 XS4Q 6K301AF 1 207 615 IWD LD PTFE 79,8x18,8</p> <p>N:← 562.653 84FM 6L270A1A 6 135 090 ASW RD FPM 28x38x7</p>	<p>TLS 733.870</p> 

FORD

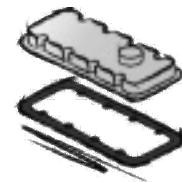
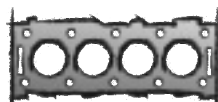
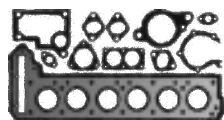

RFD
RFK

4 Cyl. 1753 ccm
Cyl. 82,5 Ø

Escort TD

02/1993 → 08/2000

Orion TD

03/1992 → 12/1993

ES⊕ **214.700**
89FF 6014AB
1 665 147
→07/1992



ES⊕ **214.711**
07/1992→
→06/1998



CS* **468.410**
91FF 6013AA
1 662 772



AL
CS* **468.690**
89FF 6013AB
1 665 146



FE

919.942 ●
90FF 6051AAA
6 474 024
0,500 mm
→
0,680 mm
1,36 mm ± 83,8 Ø
→07/1992



424.040 ●
90FF 6051BAA
1 662 936
0,500 mm
→
0,680 mm
1,36 mm ± 84,8 Ø
2 ▽
→07/1992



919.950
90FF 6051ABA
6 474 025
0,680 mm
→
0,740 mm
1,42 mm ± 83,8 Ø
→07/1992



424.050 ●
90FF 6051BBA
1 662 937
0,690 mm
→
0,740 mm
1,42 mm ± 84,8 Ø
3 ▽
→07/1992



919.969 ●
90FF 6051ACA
6 474 026
0,750 mm
→
0,840 mm
1,52 mm ± 83,8 Ø
→07/1992



424.070 ●
90FF 6051BCA
1 662 938
0,750 mm
→
0,840 mm
1,52 mm ± 84,8 Ø
4 ▽
→07/1992



164.241
1 303 931
0,500 mm
→
0,680 mm
1,36 mm ± 83,8 Ø
07/1992→



ZKS **802.940**
6 175 359 (10x)
7/16"x135
→07/1992



ZKS **802.880**
6 732 295 (10x)
M 12x1,75x136
07/1992→

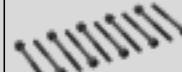

ZKHS **428.910**
06/1998→

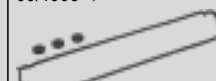

916.005
89FF 6K260AE
6 185 881
→06/1998

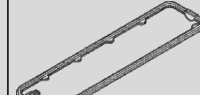















027.570
XS4Q 6K260AB
1 078 524
06/1998→



921.513
XS4Q 6P062AA
6 177 035
3x
→06/1998



			<p>a) </p> <p>b) </p>	<p>K: </p> <p>N: </p>	
<p>562.645 84FM 6571CA 1 635 583 FPM →07/1992 8x</p> <p>761.389 86TM 6571AB 1 644 647 FPM 07/1992→ 8x</p>	<p>128.162 4M5Q 9448AA 1 352 847</p> 	<p>406.490 1S4Q 9441AA 1 113 080</p>  <p>944.110 Metal 1S4Q 9441AA 1 113 080</p> 	<p>a) 468.631 XS4Q 6710BC 1 075 963</p>  <p>AL</p>  <p>a) 919.985 89FF 6710BA 1 651 865</p>  <p>FE</p>  <p>b) 012.001 97JM 6730BA 1 013 938 M 14x1,5x20</p> <p>b) 176.090 97JM 6734BA 1 005 593 13x22,4x3</p> <p>b) 422.090 92FF 6734AA 6 835 866 NBR A 14x24x1,5 FE/NBR</p>	<p>K:← 919.994 93FF 6700AB 1 075 771 ASW RD FPM 66,67x89,3x10</p> <p>K:→ 550.680 1 032 209 ASW LD PTFE/FPM 79,33x95,28x11</p> <p>K:→ 763.713 86HM 6701A1A 1 641 893 AW/BS LD FPM 79,33x95,25x11</p> <p>N:← 562.653 84FM 6L270A1A 6 135 090 ASW RD FPM 28x38x7</p>	

FORD

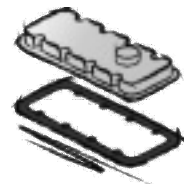
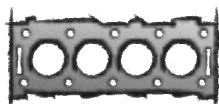
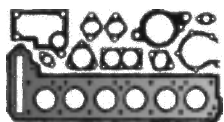

RFD
RFK

4 Cyl. 1753 ccm
Cyl. 82,5 Ø

Escort TD

02/1993 → 08/2000

Orion TD

03/1992 → 12/1993

ES⊕ **214.700**
89FF 6014AB
1 665 147
→07/1992



ES⊕ **214.711**
07/1992→
→06/1998



CS* **468.410**
91FF 6013AA
1 662 772



AL
CS* **468.690**
89FF 6013AB
1 665 146



FE

424.081 ●
XS4Q 6051SA
1 068 122

0,500 mm
→
0,680 mm



1,36 mm $\frac{\pm}{\pm}$ 84,8 Ø
2 ▽
07/1992→

164.261

1 315 704
 0,690 mm
→
0,740 mm



1,42 mm $\frac{\pm}{\pm}$ 83,8 Ø
07/1992→

424.091 ●
XS4Q 6051TA
1 068 123

0,690 mm
→
0,740 mm



1,42 mm $\frac{\pm}{\pm}$ 84,8 Ø
3 ▽
07/1992→

164.271

1 315 705
 0,750 mm
→
0,840 mm



1,52 mm $\frac{\pm}{\pm}$ 83,8 Ø
07/1992→

424.101 ●
XS4Q 6051VA
1 068 124

0,750 mm
→
0,840 mm



1,52 mm $\frac{\pm}{\pm}$ 84,8 Ø
4 ▽
07/1992→

ZKS **802.940**
6 175 359 (10x)
7/16"x135
→07/1992



ZKS **802.880**
6 732 295 (10x)
M 12x1,75x136
07/1992→



ZKHS **428.910**
06/1998→

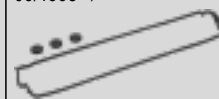

916.005
89FF 6K260AE
6 185 881
→06/1998

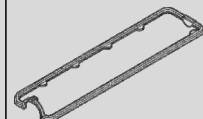



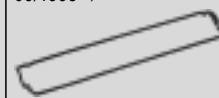











027.570
XS4Q 6K260AB
1 078 524
06/1998→



921.513
XS4Q 6P062AA
6 177 035
3x
→06/1998

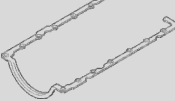

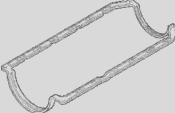
			<p>a) </p> <p>b) </p>	<p>K: </p> <p>N: </p>	
<p>562.645 84FM 6571CA 1 635 583 FPM →07/1992 8x</p> <p>761.389 86TM 6571AB 1 644 647 FPM 07/1992→ 8x</p>	<p>128.162 4M5Q 9448AA 1 352 847</p> 	<p>406.490 1S4Q 9441AA 1 113 080</p>  <p>944.110 Metal 1S4Q 9441AA 1 113 080</p> 	<p>a) 468.631 XS4Q 6710BC 1 075 963</p>  <p>AL</p>  <p>a) 919.985 89FF 6710BA 1 651 865</p>  <p>FE</p>  <p>b) 012.001 97JM 6730BA 1 013 938 M 14x1,5x20</p> <p>b) 176.090 97JM 6734BA 1 005 593 13x22,4x3</p> <p>b) 422.090 92FF 6734AA 6 835 866 NBR A 14x24x1,5 FE/NBR</p>	<p>K:← 919.994 93FF 6700AB 1 075 771 ASW RD FPM 66,67x89,3x10</p> <p>K:→ 550.680 1 032 209 ASW LD PTFE/FPM 79,33x95,28x11</p> <p>K:→ 763.713 86HM 6701A1A 1 641 893 AW/BS LD FPM 79,33x95,25x11</p> <p>N:← 562.653 84FM 6L270A1A 6 135 090 ASW RD FPM 28x38x7</p>	

FORD

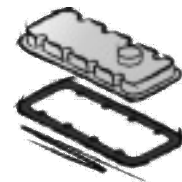
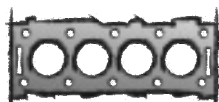
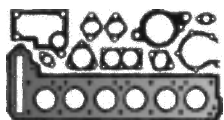

D18TRFL
RFB

RFA
RFL

4 Cyl. **1753 ccm**
Cyl. 82,5 Ø

Escort TD

05/1991 → 12/1992

Fiesta

07/1993 → 08/1995

Fiesta TD

03/1993 → 12/1995

P 100 TD

10/1987 → 12/1992

Sierra TD

08/1988 → 02/1993

ES⊕ **214.700**
89FF 6014AB
1 665 147
→07/1992



ES⊕ **214.711**
07/1992→



CS* **468.410**
91FF 6013AA
1 662 772



AL

CS* **468.690**
89FF 6013AB
1 665 146



FE

919.942 ●
90FF 6051AAA
6 474 024
→ 0,500 mm
→ 0,680 mm
1,36 mm ± 83,8 Ø
→07/1992



424.040 ●
90FF 6051BAA
1 662 936
→ 0,500 mm
→ 0,680 mm
1,36 mm ± 84,8 Ø
2 ▽
→07/1992



919.950
90FF 6051ABA
6 474 025
→ 0,680 mm
→ 0,740 mm
1,42 mm ± 83,8 Ø
→07/1992



424.050 ●
90FF 6051BBA
1 662 937
→ 0,690 mm
→ 0,740 mm
1,42 mm ± 84,8 Ø
3 ▽
→07/1992



919.969 ●
90FF 6051ACA
6 474 026
→ 0,750 mm
→ 0,840 mm
1,52 mm ± 83,8 Ø
→07/1992



424.070 ●
90FF 6051BCA
1 662 938
→ 0,750 mm
→ 0,840 mm
1,52 mm ± 84,8 Ø
4 ▽
→07/1992



164.241
1 303 931
→ 0,500 mm
→ 0,680 mm
1,36 mm ± 83,8 Ø
07/1992→



ZKS 802.940
6 175 359 (10x)
7/16"x135
→07/1992



ZKS 802.880
6 732 295 (10x)
M 12x1,75x136
07/1992→

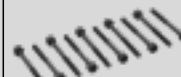



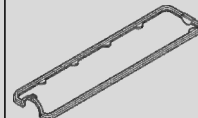











916.005
89FF 6K260AE
6 185 881



921.513
XS4Q 6P062AA
6 177 035
3x



			<p>a) </p> <p>b) </p>	<p>K: </p> <p>N: </p>	
<p>562.645 84FM 6571CA 1 635 583 FPM →07/1992 8x</p> <p>761.389 86TM 6571AB 1 644 647 FPM 07/1992→ 8x</p>	<p>128.162 4M5Q 9448AA 1 352 847</p> 	<p>406.490 1S4Q 9441AA 1 113 080</p>  <p>944.110 Metal 1S4Q 9441AA 1 113 080</p> 	<p>a) 468.631 XS4Q 6710BC 1 075 963</p>  <p>AL</p>  <p>a) 919.985 89FF 6710BA 1 651 865</p>  <p>FE</p>  <p>b) 012.001 97JM 6730BA 1 013 938 M 14x1,5x20</p> <p>b) 176.090 97JM 6734BA 1 005 593 13x22,4x3</p> <p>b) 422.090 92FF 6734AA 6 835 866 NBR A 14x24x1,5 FE/NBR</p>	<p>K:← 919.994 93FF 6700AB 1 075 771 ASW RD FPM 66,67x89,3x10</p> <p>K:→ 550.680 1 032 209 ASW LD PTFE/FPM 79,33x95,28x11</p> <p>K:→ 763.713 86HM 6701A1A 1 641 893 AW/BS LD FPM 79,33x95,25x11</p> <p>N:← 562.653 84FM 6L270A1A 6 135 090 ASW RD FPM 28x38x7</p>	

FORD

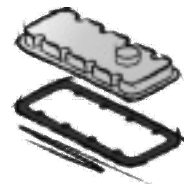
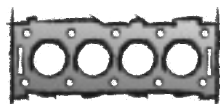
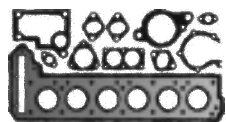

D18TRFL RFA
RFB RFL

4 Cyl. **1753 ccm**
Cyl. 82,5 Ø

Escort TD
05/1991 → 12/1992

Fiesta
07/1993 → 08/1995

Fiesta TD
03/1993 → 12/1995

P 100 TD
10/1987 → 12/1992

Sierra TD
08/1988 → 02/1993

ES⊕ **214.700**
89FF 6014AB
1 665 147
→07/1992



ES⊕ **214.711**
07/1992→



CS* **468.410**
91FF 6013AA
1 662 772



AL
CS* **468.690**
89FF 6013AB
1 665 146



FE

424.081 ●
XS4Q 6051SA
1 068 122
→ 0,500 mm
→ 0,680 mm



1,36 mm ≙ 84,8 Ø
2 ▽
07/1992→

164.261
1 315 704
→ 0,690 mm
→ 0,740 mm



1,42 mm ≙ 83,8 Ø
07/1992→

424.091 ●
XS4Q 6051TA
1 068 123
→ 0,690 mm
→ 0,740 mm



1,42 mm ≙ 84,8 Ø
3 ▽
07/1992→

164.271
1 315 705
→ 0,750 mm
→ 0,840 mm
1,52 mm ≙ 83,8 Ø
07/1992→



424.101 ●
XS4Q 6051VA
1 068 124
→ 0,750 mm
→ 0,840 mm
1,52 mm ≙ 84,8 Ø
4 ▽
07/1992→



ZKS **802.940**
6 175 359 (10x)
7/16"x135
→07/1992



ZKS **802.880**
6 732 295 (10x)
M 12x1,75x136
07/1992→

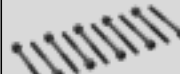



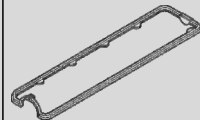











916.005
89FF 6K260AE
6 185 881



921.513
XS4Q 6P062AA
6 177 035
3x

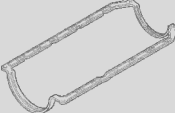

			<p>a) </p> <p>b) </p>	<p>K: </p> <p>N: </p>	
<p>562.645 84FM 6571CA 1 635 583 FPM →07/1992 8x</p> <p>761.389 86TM 6571AB 1 644 647 FPM 07/1992→ 8x</p>	<p>128.162 4M5Q 9448AA 1 352 847</p> 	<p>406.490 1S4Q 9441AA 1 113 080</p>  <p>944.110 Metal 1S4Q 9441AA 1 113 080</p> 	<p>a) 468.631 XS4Q 6710BC 1 075 963</p>  <p>AL</p>  <p>a) 919.985 89FF 6710BA 1 651 865</p>  <p>FE</p>  <p>b) 012.001 97JM 6730BA 1 013 938 M 14x1,5x20</p> <p>b) 176.090 97JM 6734BA 1 005 593 13x22,4x3</p> <p>b) 422.090 92FF 6734AA 6 835 866 NBR A 14x24x1,5 FE/NBR</p>	<p>K:← 919.994 93FF 6700AB 1 075 771 ASW RD FPM 66,67x89,3x10</p> <p>K:→ 550.680 1 032 209 ASW LD PTFE/FPM 79,33x95,28x11</p> <p>K:→ 763.713 86HM 6701A1A 1 641 893 AW/BS LD FPM 79,33x95,25x11</p> <p>N:← 562.653 84FM 6L270A1A 6 135 090 ASW RD FPM 28x38x7</p>	

FORD

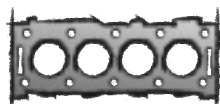
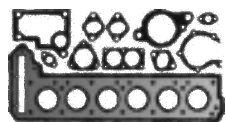

**RFN
RVA**

4 Cyl. 1753 ccm
Cyl. 82,5 Ø

Escort
12/1995 → 06/2001

Escort TD
01/1995 → 02/1999

Mondeo TD
06/1993 → 09/2000

ES⊕ **214.711**
→06/1998



CS* **468.410**
91FF 6013AA
1 662 772



AL
CS* **468.690**
89FF 6013AB
1 665 146



FE

164.241
1 303 931
→ 0,500 mm
→ 0,680 mm
1,36 mm ± 83,8 Ø



424.081 ●
XS4Q 6051SA
1 068 122
→ 0,500 mm
→ 0,680 mm
1,36 mm ± 84,8 Ø
2 ▽



164.261
1 315 704
→ 0,690 mm
→ 0,740 mm
1,42 mm ± 83,8 Ø



424.091 ●
XS4Q 6051TA
1 068 123
→ 0,690 mm
→ 0,740 mm
1,42 mm ± 84,8 Ø
3 ▽



164.271
1 315 705
→ 0,750 mm
→ 0,840 mm
1,52 mm ± 83,8 Ø



424.101 ●
XS4Q 6051VA
1 068 124
→ 0,750 mm
→ 0,840 mm
1,52 mm ± 84,8 Ø
4 ▽



ZKS **802.880**
6 732 295 (10x)
M 12x1,75x136

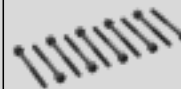

ZKHS **428.910**
06/1998→



916.005
89FF 6K260AE
6 185 881
→06/1998

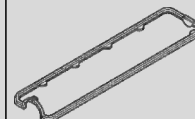



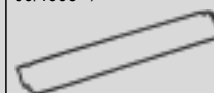











027.570
XS4Q 6K260AB
1 078 524
06/1998→



921.513
XS4Q 6P062AA
6 177 035
3x



			<p>a) </p> <p>b) </p>	<p>K: </p> <p>N: </p>	
<p>761.389 86TM 6571AB 1 644 647 FPM 8x</p>	<p>128.162 4M5Q 9448AA 1 352 847</p> 	<p>406.490 1S4Q 9441AA 1 113 080</p>  <p>944.110 Metal 1S4Q 9441AA 1 113 080</p> 	<p>a) 468.631 XS4Q 6710BC 1 075 963</p>  <p>AL</p>  <p>a) 919.985 89FF 6710BA 1 651 865</p>  <p>FE</p>  <p>b) 012.001 97JM 6730BA 1 013 938 M 14x1,5x20</p> <p>b) 176.090 97JM 6734BA 1 005 593 13x22,4x3</p> <p>b) 422.090 92FF 6734AA 6 835 866 NBR A 14x24x1,5 FE/NBR</p>	<p>K:← 919.994 93FF 6700AB 1 075 771 ASW RD FPM 66,67x89,3x10</p> <p>K:→ 550.680 1 032 209 ASW LD PTFE/FPM 79,33x95,28x11</p> <p>K:→ 763.713 86HM 6701A1A 1 641 893 AW/BS LD FPM 79,33x95,25x11</p> <p>N:← 562.653 84FM 6L270A1A 6 135 090 ASW RD FPM 28x38x7</p>	

FORD

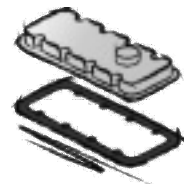
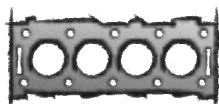
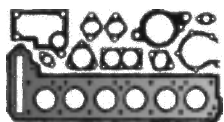

RFM
RFS

4 Cyl. **1753 ccm**
Cyl. 82,5 Ø

Escort TD

02/1993 → 08/2000

Mondeo TD

06/1993 → 08/1996

ES⊕ **214.711**



CS*

468.410
91FF 6013AA
1 662 772



AL

CS*

468.690
89FF 6013AB
1 665 146



FE

164.241

1 303 931

0,500 mm
→
0,680 mm

1,36 mm $\frac{1}{2}$ 83,8 Ø

424.081 ●

XS4Q 6051SA

1 068 122

0,500 mm
→
0,680 mm

1,36 mm $\frac{1}{2}$ 84,8 Ø

2 ▽

164.261

1 315 704

0,690 mm
→
0,740 mm

1,42 mm $\frac{1}{2}$ 83,8 Ø

424.091 ●

XS4Q 6051TA

1 068 123

0,690 mm
→
0,740 mm

1,42 mm $\frac{1}{2}$ 84,8 Ø

3 ▽

164.271

1 315 705

0,750 mm
→
0,840 mm

1,52 mm $\frac{1}{2}$ 83,8 Ø

424.101 ●

XS4Q 6051VA

1 068 124

0,750 mm
→
0,840 mm

1,52 mm $\frac{1}{2}$ 84,8 Ø

4 ▽

ZKS 802.880

6 732 295 (10x)

M 12x1,75x136



916.005

89FF 6K260AE

6 185 881

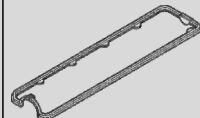















921.513

XS4Q 6P062AA

6 177 035

3x



			<p>a) </p> <p>b) </p>	<p>K: </p> <p>N: </p>	
<p>761.389 86TM 6571AB 1 644 647 FPM 8x</p>	<p>128.162 4M5Q 9448AA 1 352 847</p> 	<p>406.490 1S4Q 9441AA 1 113 080</p>  <p>944.110 Metal 1S4Q 9441AA 1 113 080</p> 	<p>a) 468.631 XS4Q 6710BC 1 075 963</p>  <p>AL</p>  <p>a) 919.985 89FF 6710BA 1 651 865</p>  <p>FE</p>  <p>b) 012.001 97JM 6730BA 1 013 938 M 14x1,5x20</p> <p>b) 176.090 97JM 6734BA 1 005 593 13x22,4x3</p> <p>b) 422.090 92FF 6734AA 6 835 866 NBR A 14x24x1,5 FE/NBR</p>	<p>K:← 919.994 93FF 6700AB 1 075 771 ASW RD FPM 66,67x89,3x10</p> <p>K:→ 550.680 1 032 209 ASW LD PTFE/FPM 79,33x95,28x11</p> <p>K:→ 763.713 86HM 6701A1A 1 641 893 AW/BS LD FPM 79,33x95,25x11</p> <p>N:← 562.653 84FM 6L270A1A 6 135 090 ASW RD FPM 28x38x7</p>	

FORD

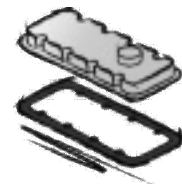
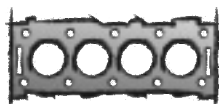
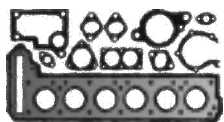

RTA
RTB

4 Cyl. **1753 ccm**
Cyl. 82,5 Ø

Escort
07/1988 → 12/1994

Orion
01/1989 → 07/1990

ES⊕ **919.934 ●**
89FF 6014AB
1 665 147
+E 85217S
+96FF 9448AA
+84FM 6571CA (8x)
+6 740 296
+1 665 182
+1 635 583 (8x)



CS* **468.410**
91FF 6013AA
1 662 772



AL **468.690**
89FF 6013AB
1 665 146



FE

919.942 ●
90FF 6051AAA
6 474 024
 0,500 mm
→
0,680 mm
1,36 mm \pm 83,8 Ø



424.040 ●
90FF 6051BAA
1 662 936
 0,500 mm
→
0,680 mm
1,36 mm \pm 84,8 Ø
2 ▽



919.950
90FF 6051ABA
6 474 025
 0,680 mm
→
0,740 mm
1,42 mm \pm 83,8 Ø



424.050 ●
90FF 6051BBA
1 662 937
 0,690 mm
→
0,740 mm
1,42 mm \pm 84,8 Ø
3 ▽



919.969 ●
90FF 6051ACA
6 474 026
 0,750 mm
→
0,840 mm
1,52 mm \pm 83,8 Ø



424.070 ●
90FF 6051BCA
1 662 938
 0,750 mm
→
0,840 mm
1,52 mm \pm 84,8 Ø
4 ▽



ZKS **802.940**
6 175 359 (10x)
7/16"x135





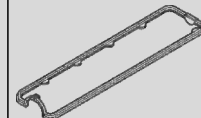











916.005
89FF 6K260AE
6 185 881



921.513
XS4Q 6P062AA
6 177 035
3x



			<p>a) </p> <p>b) </p>	<p>K: </p> <p>N: </p>	
<p>562.645 84FM 6571CA 1 635 583 FPM 8x</p>	<p>128.162 4M5Q 9448AA 1 352 847</p> 	<p>919.977 89FF 9441AA 6 169 448</p> 	<p>a) 468.631 XS4Q 6710BC 1 075 963</p>  <p>AL</p>  <p>a) 919.985 89FF 6710BA 1 651 865</p>  <p>FE</p>  <p>b) 422.090 92FF 6734AA 6 835 866 NBR A 14x24x1,5 FE/NBR</p>	<p>K:← 919.994 93FF 6700AB 1 075 771 ASW RD FPM 66,67x89,3x10</p> <p>K:→ 550.680 1 032 209 ASW LD PTFE/FPM 79,33x95,28x11</p> <p>K:→ 763.713 86HM 6701A1A 1 641 893 AW/BS LD FPM 79,33x95,25x11</p> <p>N:← 562.653 84FM 6L270A1A 6 135 090 ASW RD FPM 28x38x7</p>	

FORD

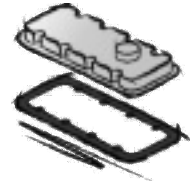

RTC **RTD**
RTE **RTF**
RTG **RTH**

4 Cyl. **1753 ccm**
Cyl. 82,5 Ø

Escort
07/1990 → 08/2000
Fiesta
03/1989 → 02/1996
Orion
11/1990 → 12/1993

ES⊕ **919.934 ●**
89FF 6014AB
1 665 147
+E 85217S
+96FF 9448AA
+84FM 6571CA (8x)
+6 740 296
+1 665 182
+1 635 583 (8x)
→07/1992



ES⊕ **214.711**
07/1992→



CS* **468.410**
91FF 6013AA
1 662 772



CS* **468.690**
89FF 6013AB
1 665 146



919.942 ●
90FF 6051AAA
6 474 024
 0,500 mm
→
0,680 mm
1,36 mm $\frac{\pm}{\pm}$ 83,8 Ø
→07/1992



424.040 ●
90FF 6051BAA
1 662 936
 0,500 mm
→
0,680 mm
1,36 mm $\frac{\pm}{\pm}$ 84,8 Ø
2 ▽
→07/1992



919.950
90FF 6051ABA
6 474 025
 0,680 mm
→
0,740 mm
1,42 mm $\frac{\pm}{\pm}$ 83,8 Ø
→07/1992



424.050 ●
90FF 6051BBA
1 662 937
 0,690 mm
→
0,740 mm
1,42 mm $\frac{\pm}{\pm}$ 84,8 Ø
3 ▽
→07/1992



919.969 ●
90FF 6051ACA
6 474 026
 0,750 mm
→
0,840 mm
1,52 mm $\frac{\pm}{\pm}$ 83,8 Ø
→07/1992



424.070 ●
90FF 6051BCA
1 662 938
 0,750 mm
→
0,840 mm
1,52 mm $\frac{\pm}{\pm}$ 84,8 Ø
4 ▽
→07/1992



164.241
1 303 931
 0,500 mm
→
0,680 mm
1,36 mm $\frac{\pm}{\pm}$ 83,8 Ø
07/1992→



ZKS 802.940
6 175 359 (10x)
7/16"x135
→07/1992



ZKS 802.880
6 732 295 (10x)
M 12x1,75x136
07/1992→





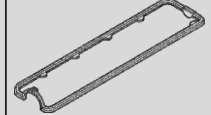











916.005
89FF 6K260AE
6 185 881



921.513
XS4Q 6P062AA
6 177 035
3x



FORD

			<p>a) </p> <p>b) </p>	<p>K: </p> <p>N: </p>	
<p>562.645 84FM 6571CA 1 635 583 FPM →07/1992 8x</p> <p>761.389 86TM 6571AB 1 644 647 FPM 07/1992→ 8x</p>	<p>128.162 4M5Q 9448AA 1 352 847</p> 	<p>919.977 89FF 9441AA 6 169 448</p> 	<p>a) 468.631 XS4Q 6710BC 1 075 963</p>  <p>AL</p>  <p>a) 919.985 89FF 6710BA 1 651 865</p>  <p>FE</p>  <p>b) 012.001 97JM 6730BA 1 013 938 M 14x1,5x20</p> <p>b) 176.090 97JM 6734BA 1 005 593 13x22,4x3</p> <p>b) 422.090 92FF 6734AA 6 835 866 NBR A 14x24x1,5 FE/NBR</p>	<p>K:← 919.994 93FF 6700AB 1 075 771 ASW RD FPM 66,67x89,3x10</p> <p>K:→ 550.680 1 032 209 ASW LD PTFE/FPM 79,33x95,28x11</p> <p>K:→ 763.713 86HM 6701A1A 1 641 893 AW/BS LD FPM 79,33x95,25x11</p> <p>N:← 562.653 84FM 6L270A1A 6 135 090 ASW RD FPM 28x38x7</p>	

FORD

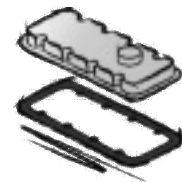
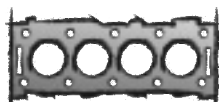
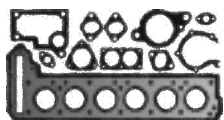

RTC **RTD**
RTE **RTF**
RTG **RTH**

4 Cyl. **1753 ccm**
Cyl. 82,5 Ø

Escort
07/1990 → 08/2000

Fiesta
03/1989 → 02/1996

Orion
11/1990 → 12/1993

ES⊕ **919.934** ●
89FF 6014AB
1 665 147
+E 85217S
+96FF 9448AA
+84FM 6571CA (8x)
+6 740 296
+1 665 182
+1 635 583 (8x)
→07/1992



ES⊕ **214.711**
07/1992→



CS* **468.410**
91FF 6013AA
1 662 772



AL
CS* **468.690**
89FF 6013AB
1 665 146



FE

424.081 ●
XS4Q 6051SA
1 068 122
 0,500 mm
→
 0,680 mm
1,36 mm ± 84,8 Ø
2 ▽
07/1992→



164.261
1 315 704
 0,690 mm
→
 0,740 mm
1,42 mm ± 83,8 Ø
07/1992→



424.091 ●
XS4Q 6051TA
1 068 123
 0,690 mm
→
 0,740 mm
1,42 mm ± 84,8 Ø
3 ▽
07/1992→



164.271
1 315 705
 0,750 mm
→
 0,840 mm
1,52 mm ± 83,8 Ø
07/1992→



424.101 ●
XS4Q 6051VA
1 068 124
 0,750 mm
→
 0,840 mm
1,52 mm ± 84,8 Ø
4 ▽
07/1992→



ZKS **802.940**
6 175 359 (10x)
7/16"x135
→07/1992



ZKS **802.880**
6 732 295 (10x)
M 12x1,75x136
07/1992→

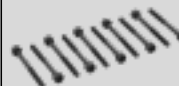



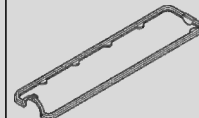









916.005
89FF 6K260AE
6 185 881

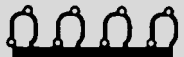

921.513
XS4Q 6P062AA
6 177 035
3x



			<p>a) </p> <p>b) </p>	<p>K: </p> <p>N: </p>	
<p>562.645 84FM 6571CA 1 635 583 FPM →07/1992 8x</p> <p>761.389 86TM 6571AB 1 644 647 FPM 07/1992→ 8x</p>	<p>128.162 4M5Q 9448AA 1 352 847</p> 	<p>919.977 89FF 9441AA 6 169 448</p> 	<p>a) 468.631 XS4Q 6710BC 1 075 963</p>  <p>AL</p>  <p>a) 919.985 89FF 6710BA 1 651 865</p>  <p>FE</p>  <p>b) 012.001 97JM 6730BA 1 013 938 M 14x1,5x20</p> <p>b) 176.090 97JM 6734BA 1 005 593 13x22,4x3</p> <p>b) 422.090 92FF 6734AA 6 835 866 NBR A 14x24x1,5 FE/NBR</p>	<p>K:← 919.994 93FF 6700AB 1 075 771 ASW RD FPM 66,67x89,3x10</p> <p>K:→ 550.680 1 032 209 ASW LD PTFE/FPM 79,33x95,28x11</p> <p>K:→ 763.713 86HM 6701A1A 1 641 893 AW/BS LD FPM 79,33x95,25x11</p> <p>N:← 562.653 84FM 6L270A1A 6 135 090 ASW RD FPM 28x38x7</p>	

FORD

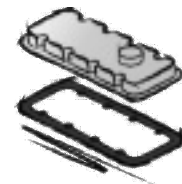
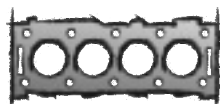
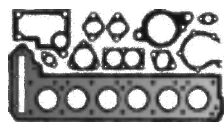

RTJ
RTK

4 Cyl. 1753 ccm
Cyl. 82,5 Ø

Courier
06/1999 → 02/2002
Fiesta
08/1995 → 04/2002

ES⊕ **214.711**
→06/1998



CS* **468.410**
91FF 6013AA
1 662 772



AL
CS* **468.690**
89FF 6013AB
1 665 146



FE

164.241
1 303 931
→ 0,500 mm
→ 0,680 mm
1,36 mm $\frac{1}{2}$ 83,8 Ø



424.081 ●
XS4Q 6051SA
1 068 122
→ 0,500 mm
→ 0,680 mm
1,36 mm $\frac{1}{2}$ 84,8 Ø
2 ▽



164.261
1 315 704
→ 0,690 mm
→ 0,740 mm
1,42 mm $\frac{1}{2}$ 83,8 Ø



424.091 ●
XS4Q 6051TA
1 068 123
→ 0,690 mm
→ 0,740 mm
1,42 mm $\frac{1}{2}$ 84,8 Ø
3 ▽



164.271
1 315 705
→ 0,750 mm
→ 0,840 mm
1,52 mm $\frac{1}{2}$ 83,8 Ø



424.101 ●
XS4Q 6051VA
1 068 124
→ 0,750 mm
→ 0,840 mm
1,52 mm $\frac{1}{2}$ 84,8 Ø
4 ▽



ZKS **802.880**
6 732 295 (10x)
M 12x1,75x136



ZKHS **428.910**
06/1998→



916.005
89FF 6K260AE
6 185 881
→06/1998





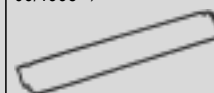









027.570
XS4Q 6K260AB
1 078 524
06/1998→

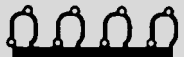

921.513
XS4Q 6P062AA
6 177 035
3x



			<p>a) </p> <p>b) </p>	<p>K: </p> <p>N: </p>	
<p>761.389 86TM 6571AB 1 644 647 FPM 8x</p>	<p>128.162 4M5Q 9448AA 1 352 847</p> 	<p>919.977 89FF 9441AA 6 169 448</p> 	<p>a) 468.631 XS4Q 6710BC 1 075 963</p>  <p>AL</p>  <p>a) 919.985 89FF 6710BA 1 651 865</p>  <p>FE</p>  <p>b) 012.001 97JM 6730BA 1 013 938 M 14x1,5x20</p> <p>b) 176.090 97JM 6734BA 1 005 593 13x22,4x3</p> <p>b) 422.090 92FF 6734AA 6 835 866 NBR A 14x24x1,5 FE/NBR</p>	<p>K:← 919.994 93FF 6700AB 1 075 771 ASW RD FPM 66,67x89,3x10</p> <p>K:→ 550.680 1 032 209 ASW LD PTFE/FPM 79,33x95,28x11 →08/1998</p> <p>K:→ 763.713 86HM 6701A1A 1 641 893 AW/BS LD FPM 79,33x95,25x11 →08/1998</p> <p>K:→ 026.821 XS4Q 6K301AF 1 207 615 IWD LD PTFE 79,8x18,8 09/1998→</p> <p>N:← 562.653 84FM 6L270A1A 6 135 090 ASW RD FPM 28x38x7</p>	

FORD

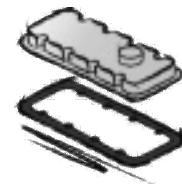
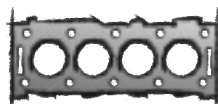
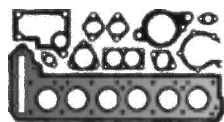

RTN RTP
RTQ

4 Cyl. **1753 ccm**
Cyl. 82,5 Ø

Fiesta DI
04/2000 → 08/2003

Fiesta TD
03/2000 → 08/2003

ES⊕ **030.492**



CS* **030.460**

027.062

1S4Q 6051GB
1 477 466



↕ 0,550 mm
→
0,600 mm

1,27 mm $\frac{\pm}{\pm}$

2 ⊗

027.072

1S4Q 6051HB
1 477 467



↕ 0,601 mm
→
0,650 mm

1,32 mm $\frac{\pm}{\pm}$

3 ⊗

027.082

1S4Q 6051JB
1 477 470



↕ 0,651 mm
→
0,700 mm

1,37 mm $\frac{\pm}{\pm}$

4 ⊗

027.092

1S4Q 6051KB
1 477 472



↕ 0,701 mm
→
0,750 mm

1,42 mm $\frac{\pm}{\pm}$

5 ⊗

027.102

1S4Q 6051LB
1 477 473



↕ 0,751 mm
→
0,800 mm

1,47 mm $\frac{\pm}{\pm}$

6 ⊗

027.112

1S4Q 6051MB
1 477 474



↕ 0,801 mm
→
0,850 mm

1,52 mm $\frac{\pm}{\pm}$

7 ⊗

ZKS **027.850**

1 079 925 (2x)
+1 079 926 (8x)
M 12x1,5x137/177



ZKHS **428.910**



027.570
XS4Q 6K260AB
1 078 524

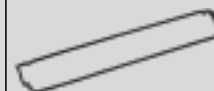

R2A R2C

4 Cyl. **1769 ccm**
Cyl. 80,0 Ø

Sierra
01/1987 → 02/1993

920.762

E9RE 6051AA
6 467 942

























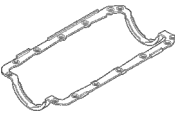



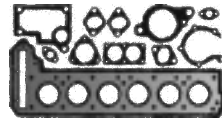
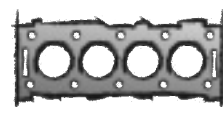

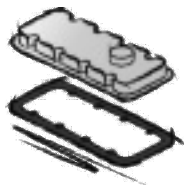
1,80 mm $\frac{\pm}{\pm}$ 82,2 Ø



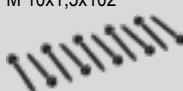
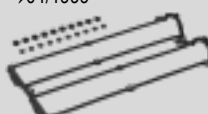
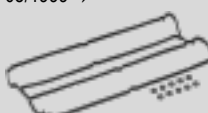

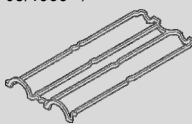

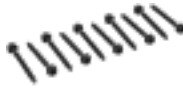
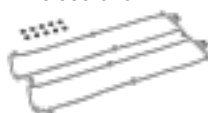
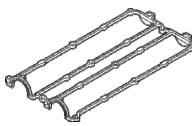







920.770 ●

E7EE 6584C8B
1 641 037



			<p>a) </p> <p>b) </p>	<p>K: </p> <p>N: </p>	
<p>761.389 86TM 6571AB 1 644 647 FPM 8x</p>	<p>128.162 4M5Q 9448AA 1 352 847</p> 	<p>406.490 1S4Q 9441AA 1 113 080</p>  <p>944.110 Metal 1S4Q 9441AA 1 113 080</p> 	<p>a) 027.330 XS4Q 6710AE 1 078 498</p>  <p>a) 036.164 Dirko HT / EU</p> <p>a) 510.031 Dirko HT / USA/CDN/MEX</p> <p>a) 527.291 Dirko HT / RU</p> <p>a) 648.661 Dirko HT / BR</p> <p>b) 012.001 97JM 6730BA 1 013 938 M 14x1,5x20</p> <p>b) 176.090 97JM 6734BA 1 005 593 13x22,4x3</p>	<p>K:← 026.770 XS4Q 6700AD 1 198 045 ASW RD PTFE/ACM 30x50x7,5</p> <p>K:→ 026.821 XS4Q 6K301AF 1 207 615 IWD LD PTFE 79,8x18,8</p> <p>N:← 562.653 84FM 6L270A1A 6 135 090 ASW RD FPM 28x38x7</p>	
<p>405.990 81SM 6571A2F 6 674 302 FPM 8x</p>	<p>705.811 91SM 9448AB 6 591 016</p> 	<p>920.789 E7EE 9439A6C 1 651 564</p> 	<p>a) 920.797 FORE 6710AA 6 617 098</p>  <p>b) 786.500 928M 6734AA 1 454 118 Nylon A 14,5x22x2</p>	<p>K:← 757.292 928M 6700B5A 6 165 500 ASW RD FPM 35x50x7</p> <p>K:→ 750.476 928M 6701B5A 6 126 179 ASW LD FPM 88x108x11</p> <p>N:← 757.497 86HM 6700AA 1 669 254 ASW RD FPM 42x56x7</p>	

<p>FORD</p> 				
<p> EYDB EYDC EYDD EYDE EYDF EYDG EYDI EYDJ EYDL EYPA EYPB EYPC EYPD </p> <p>4 Cyl. 1796 ccm Cyl. 80,6 Ø</p> <p>Focus 10/1998 → 03/2005</p> <p>Tourneo Connect 06/2002 → 12/2013</p> <p>Transit Connect 06/2002 → 12/2013</p>	<p>ES⊕ 025.890 →09/1999</p>  <p>ES⊕ 434.510 09/1999→</p>  <p>CS* 338.820</p>	<p>287.500 XS7G-6051BC 1 308 383 0,64 mm $\frac{1}{16}$ 81,6 Ø</p> 	<p>ZKS 802.870 1 024 355 (10x) M 10x1,5x102</p> 	<p>ZKHS 569.460 →04/1999</p>  <p>ZKHS 389.060 05/1999→</p>  <p>377.160 988M 6584AE 1 061 468 →04/1999</p>  <p>364.381 XS7G 6584AC 1 126 120 05/1999→</p>  <p>198.240 6 759 630 9x14x5 10x</p> 
<p> RDA RDB RKC RQB RQC </p> <p>4 Cyl. 1796 ccm Cyl. 80,6 Ø</p> <p>Escort 02/1992 → 08/2000</p> <p>Fiesta 02/1992 → 12/1995</p> <p>Orion 01/1992 → 12/1993</p>	<p>ES⊕ 458.491 938X 6014AA 5 028 414</p> <p>CS* 458.600 938X 6013AB 5 031 032</p>	<p>646.480 928M 6051BH 6 847 748</p>  <p>82 Ø</p>	<p>ZKS 802.870 1 024 355 (10x) M 10x1,5x102</p> 	<p>ZKHS 389.070</p>  <p>458.660 928M 6584C1B 1 663 394</p>  <p>198.240 6 759 630 9x14x5 10x</p> 

			<p>a) </p> <p>b) </p>	<p>K: </p> <p>N: </p>	
<p>127.490 958M 6571BD 1 086 432 FPM 8x</p> <p>127.510 958M 6571CC 1 086 431 FPM 8x</p>	<p>267.701 968M 9448AA 1 053 902</p> 	<p>476.551 988M 9461AA 1 048 093 →09/1999 4x</p>  <p>364.071 XS7G 9461BA 1 090 949 10/1999→ 4x</p> 	<p>a) 036.164 Dirko HT / EU</p> <p>a) 510.031 Dirko HT / USA/CDN/MEX</p> <p>a) 527.291 Dirko HT / RU</p> <p>a) 648.661 Dirko HT / BR</p> <p>a) 388.160 988M 6710AG 1 078 707 ↑</p>  <p>b) 012.001 97JM 6730BA 1 013 938 M 14x1,5x20</p> <p>b) 176.090 97JM 6734BA 1 005 593 13x22,4x3</p>	<p>K:← 374.680 988M 6700A5B 1 102 415 ASW RD PTFE/ACM 35x50x7</p> <p>K:← 757.292 928M 6700B5A 6 165 500 ASW RD FPM 35x50x7</p> <p>K:→ 374.590 1M5G 6A321A5A 1 220 978 ASW LD PTFE/ACM 88x108x10</p> <p>K:→ 750.476 928M 6701B5A 6 126 179 ASW LD FPM 88x108x11</p> <p>N:← 467.860 928M 6K292B5B 1 067 029 AS OF RD FPM 42x53x7 2x</p>	
<p>VAS 214.540</p> <p>127.490 958M 6571BD 1 086 432 FPM 8x</p> <p>127.510 958M 6571CC 1 086 431 FPM 8x</p>	<p>446.481 958M 9448AA 1 044 867</p> 	<p>446.461 928F-9441DB 1 663 389</p>  <p>829.473 928M 9441GB 6 669 767</p>	<p>a) 467.830 938M 6710AC 7 008 824</p>  <p>b) 786.500 928M 6734AA 1 454 118 Nylon A 14,5x22x2</p>	<p>K:← 374.680 988M 6700A5B 1 102 415 ASW RD PTFE/ACM 35x50x7</p> <p>K:← 757.292 928M 6700B5A 6 165 500 ASW RD FPM 35x50x7</p> <p>K:→ 374.590 1M5G 6A321A5A 1 220 978 ASW LD PTFE/ACM 88x108x10</p> <p>K:→ 750.476 928M 6701B5A 6 126 179 ASW LD FPM 88x108x11</p> <p>N:← 467.860 928M 6K292B5B 1 067 029 AS OF RD FPM 42x53x7 2x</p>	

FORD

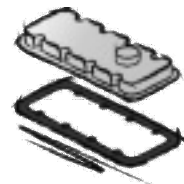
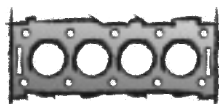
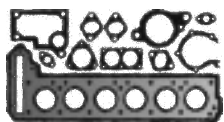

RKA **RKB**
RKF **RKH**
RKJ **RKK**

 4 Cyl. 1796 ccm
 Cyl. 80,6 Ø

Courier
 03/1998 → 02/2002
Mondeo
 02/1993 → 09/2000
Ranger
 06/1999 → 02/2002

ES⊕ **458.571**
 938X 6014BA
 5 028 415
 →05/1998
 ES⊕ **569.450**
 06/1998→
 →04/1999
 ES⊕ **569.850**
 05/1999→
 CS* **458.600**
 938X 6013AB
 5 031 032
 →05/1998
 CS* **338.820**
 06/1998→

646.480
 928M 6051BH
 6 847 748

 →05/1998 82 Ø
476.213
 1,00 mm ± 81,6 Ø
 06/1998→
 →04/1999
287.500
 XS7G-6051BC
 1 308 383
 0,64 mm ± 81,6 Ø
 05/1999→

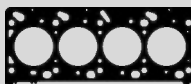

ZKS 802.870
 1 024 355 (10x)
 M 10x1,5x102

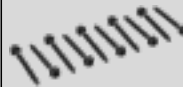

ZKHS 389.070
 →05/1998



ZKHS 569.460
 06/1998→
 →04/1999



ZKHS 389.060
 05/1999→



458.660
 928M 6584C1B
 1 663 394
 →05/1998



377.160
 988M 6584AE
 1 061 468
 06/1998→
 →04/1999

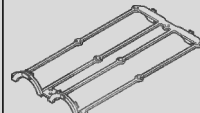



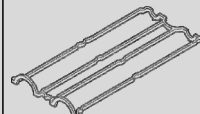























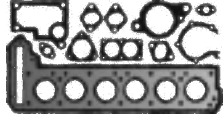
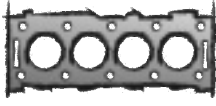

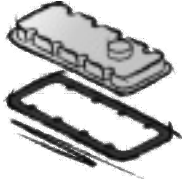





364.381
 XS7G 6584AC
 1 126 120
 05/1999→





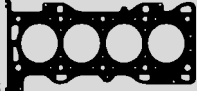

















198.240
 6 759 630
 9x14x5
 10x



			<p>a) </p> <p>b) </p>	<p>K: </p> <p>N: </p>	
<p>VAS 214.540 127.490 958M 6571BD 1 086 432 FPM 8x</p> <p>127.510 958M 6571CC 1 086 431 FPM 8x</p>	<p>446.481 958M 9448AA 1 044 867 →01/1999</p>  <p>439.101 988M 9448AA 1 078 966 02/1999→</p> 	<p>832.245 938M 9441DC 6 780 895 →05/1998</p>  <p>476.551 988M 9461AA 1 048 093 06/1998→ →09/1999 4x</p>  <p>364.071 XS7G 9461BA 1 090 949 10/1999→ 4x</p> 	<p>a) 467.830 938M 6710AC 7 008 824 →05/1998</p>  <p>a) 036.164 Dirko HT / EU 06/1998→</p> <p>a) 510.031 Dirko HT / USA/CDN/MEX 06/1998→</p> <p>a) 527.291 Dirko HT / RU 06/1998→</p> <p>a) 648.661 Dirko HT / BR 06/1998→</p> <p>a) 388.160 988M 6710AG 1 078 707 ↑ 06/1998→</p>  <p>b) 012.001 97JM 6730BA 1 013 938 M 14x1,5x20</p> <p>b) 176.090 97JM 6734BA 1 005 593 13x22,4x3</p> <p>b) 786.500 928M 6734AA 1 454 118 Nylon A 14,5x22x2</p>	<p>K:← 374.680 988M 6700A5B 1 102 415 ASW RD PTFE/ACM 35x50x7</p> <p>K:← 757.292 928M 6700B5A 6 165 500 ASW RD FPM 35x50x7</p> <p>K:→ 374.590 1M5G 6A321A5A 1 220 978 ASW LD PTFE/ACM 88x108x10</p> <p>K:→ 750.476 928M 6701B5A 6 126 179 ASW LD FPM 88x108x11</p> <p>N:← 467.860 928M 6K292B5B 1 067 029 AS OF RD FPM 42x53x7 2x</p>	

<p>FORD</p> 				
<p>CGBA CGBB CHBA CHBB</p> <p>4 Cyl. 1798 ccm Cyl. 83,0 Ø</p> <p>Mondeo 10/2000 → 03/2007</p>	<p>ES⊕ 027.270</p>  <p>CS* 027.291</p>	<p>255.060 1S7G 6051BG 1 119 194 0,50 mm $\frac{2}{3}$ 84,5 Ø</p> 	<p>ZKS 028.230 1 229 267 (10x) M 10x1,25x145,5</p> 	<p>ZKHS 026.551 1S7G 6584AE 1 119 878</p>  <p>AL</p>  <p>ZKHS 001.563 1S7G 6K260AA 1 220 025</p>  <p>PLASTIC</p> 
<p>CSDA CSDB</p> <p>4 Cyl. 1798 ccm Cyl. 83,0 Ø</p> <p>Focus C-Max 10/2003 → 03/2007</p>	<p>ES⊕ 527.140 CS* 027.291</p>	<p>255.060 1S7G 6051BG 1 119 194 0,50 mm $\frac{2}{3}$ 84,5 Ø</p> 	<p>ZKS 028.230 1 229 267 (10x) M 10x1,25x145,5</p> 	<p>ZKHS 001.563 1S7G 6K260AA 1 220 025</p>  <p>PLASTIC</p> 
<p>Q7DA QQDA QQDB QQDC QQDD</p> <p>4 Cyl. 1798 ccm Cyl. 83,0 Ø</p> <p>C-Max 02/2007 → 09/2010 Focus 12/2005 → 09/2012 Focus C-Max 04/2004 → 03/2007</p>	<p>ES⊕ 027.270</p>  <p>CS* 027.291</p>	<p>255.060 1S7G 6051BG 1 119 194 0,50 mm $\frac{2}{3}$ 84,5 Ø</p> 	<p>ZKS 028.230 1 229 267 (10x) M 10x1,25x145,5</p> 	<p>ZKHS 001.563 1S7G 6K260AA 1 220 025</p>  <p>PLASTIC</p> 

			<p>a) </p> <p>b) </p>	<p>K: </p> <p>N: </p>	
<p>026.680 3S4G 6A517AA 1 151 825 FPM E 8x</p>  <p>026.650 1S7G 6A517BG 1 206 655 FPM A 8x</p> 	<p>024.390 5S43 9448AD 1 112 701</p> 	<p>874.301 1S7G 9441AE 1 119 284 4x</p> 	<p>a) 036.164 Dirko HT / EU</p> <p>a) 510.031 Dirko HT / USA/CDN/MEX</p> <p>a) 527.291 Dirko HT / RU</p> <p>a) 648.661 Dirko HT / BR</p> <p>b) 012.001 97JM 6730BA 1 013 938 M 14x1,5x20</p> <p>b) 176.090 97JM 6734BA 1 005 593 13x22,4x3</p>	<p>K:← 023.631 1S7G 6700AC 1 119 162 AS RD FPM 37x50x6</p> <p>K:← 649.250 CM5E-6700-AB AS OF RD FPM 37x50x6</p> <p>K:→ 023.940 1S7G 6A321AA 1 211 759 IWD LD PTFE 88x180x15</p>	
<p>026.680 3S4G 6A517AA 1 151 825 FPM E 8x</p>  <p>026.650 1S7G 6A517BG 1 206 655 FPM A 8x</p> 	<p>024.390 5S43 9448AD 1 112 701</p> 	<p>874.301 1S7G 9441AE 1 119 284 4x</p> 	<p>a) 036.164 Dirko HT / EU</p> <p>a) 510.031 Dirko HT / USA/CDN/MEX</p> <p>a) 527.291 Dirko HT / RU</p> <p>a) 648.661 Dirko HT / BR</p> <p>b) 012.001 97JM 6730BA 1 013 938 M 14x1,5x20</p> <p>b) 176.090 97JM 6734BA 1 005 593 13x22,4x3</p>	<p>K:← 023.631 1S7G 6700AC 1 119 162 AS RD FPM 37x50x6</p> <p>K:← 649.250 CM5E-6700-AB AS OF RD FPM 37x50x6</p> <p>K:→ 023.940 1S7G 6A321AA 1 211 759 IWD LD PTFE 88x180x15</p>	
<p>026.680 3S4G 6A517AA 1 151 825 FPM E 8x</p>  <p>026.650 1S7G 6A517BG 1 206 655 FPM A 8x</p> 	<p>024.390 5S43 9448AD 1 112 701</p> 	<p>874.301 1S7G 9441AE 1 119 284 4x</p> 	<p>a) 036.164 Dirko HT / EU</p> <p>a) 510.031 Dirko HT / USA/CDN/MEX</p> <p>a) 527.291 Dirko HT / RU</p> <p>a) 648.661 Dirko HT / BR</p> <p>b) 012.001 97JM 6730BA 1 013 938 M 14x1,5x20</p> <p>b) 176.090 97JM 6734BA 1 005 593 13x22,4x3</p>	<p>K:← 023.631 1S7G 6700AC 1 119 162 AS RD FPM 37x50x6</p> <p>K:← 649.250 CM5E-6700-AB AS OF RD FPM 37x50x6</p> <p>K:→ 023.940 1S7G 6A321AA 1 211 759 IWD LD PTFE 88x180x15</p>	

FORD

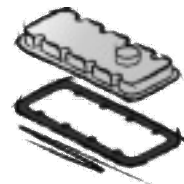
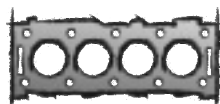
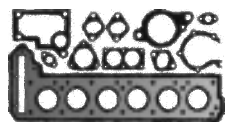

1Z
4 Cyl. **1896 ccm**
Cyl. 79,5 Ø
Galaxy TDI
03/1995 → 05/2006

ES⊕ **620.280**
95VW 6014BA
1 009 167
→04/1996
→Mot. 1Z 770 000



ES⊕ **187.400**
05/1996→
Mot. 1Z 770 001→



CS* **670.720**
95VW 6013BA
1 004 926



412.872
95VW 6051FA
1 079 766
1 005 254
0,910 mm
→
1,000 mm
1,45 mm ± 80,5 Ø
1 ⊗



412.882
95VW 6051GA
1 079 767
1 005 258



1,010 mm
→
1,100 mm
1,53 mm ± 80,5 Ø
2 ⊗

412.912
95VW 6051HA
1 079 768
1 005 261
1,110 mm
→
1,200 mm
1,61 mm ± 80,5 Ø
3 ⊗



ZKS **819.824**
M 12x1,75x115

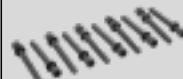

ZKHS **470.280**



619.771



915.017
3x



915.009
1 005 264
3x

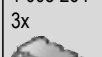

AFN
4 Cyl. **1896 ccm**
Cyl. 79,5 Ø
Galaxy TDI
08/1997 → 04/2000

ES⊕ **620.280**
95VW 6014BA
1 009 167
→Mot. AFN 002 000



ES⊕ **187.400**
Mot. AFN 002 001→



CS* **670.720**
95VW 6013BA
1 004 926
→Mot. AFN 576 000



CS* **375.540**
Mot. AFN 576 001→



412.872
95VW 6051FA
1 079 766
1 005 254
0,910 mm
→
1,000 mm
1,45 mm ± 80,5 Ø
1 ⊗



412.882
95VW 6051GA
1 079 767
1 005 258



1,010 mm
→
1,100 mm
1,53 mm ± 80,5 Ø
2 ⊗

412.912
95VW 6051HA
1 079 768
1 005 261
1,110 mm
→
1,200 mm
1,61 mm ± 80,5 Ø
3 ⊗



ZKS **819.824**
M 12x1,75x115

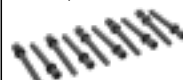

ZKHS **470.280**



619.771



















915.017
3x

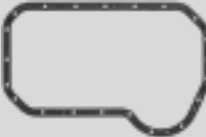

915.009
1 005 264
3x



			<p>a) </p> <p>b) </p>	<p>K: </p> <p>N: </p>	
<p>VAS 702.706 FPM →04/1996 →Mot. 1Z 770 000</p> <p>VAS 825.042 FPM 05/1996→ Mot. 1Z 770 001→</p> <p>553.190 95VW 6371BA 1 669 785 FPM →04/1996 →Mot. 1Z 770 000 8x</p> <p>701.289 95VW 6571BA 1 669 785 FPM 05/1996→ Mot. 1Z 770 001→ 8x</p>	<p>815.187 1 005 891 4x</p> 	<p>915.213 1 006 217</p> 	<p>a) 495.620 1 033 121</p>  <p>b) 878.070 M 14x1,5x16</p> <p>b) 115.100 95VW 6734AA 1 005 306 0 209 725 CU A 14x20x1,5</p>	<p>K:← 325.155 95VW 6700BA 1 004 928 ASW WD FPM/ACM 32x47x10</p> <p>K:→ 342.093 95VW 6734AA 1 005 303 ASW LD FPM 85x105x11</p> <p>K:→ 804.850 SP LD PTFE/ACM 85</p> <p>K:→ 829.056 ASW LD FPM 85x105x11</p> <p>N:← 325.155 95VW 6700BA 1 004 928 ASW WD FPM/ACM 32x47x10</p>	<p>TLS 704.010</p> 
<p>VAS 702.706 FPM →Mot. AFN 002 000</p> <p>VAS 825.042 FPM Mot. AFN 002 001→</p> <p>553.190 95VW 6371BA 1 669 785 FPM →Mot. AFN 002 000 8x</p> <p>701.289 95VW 6571BA 1 669 785 FPM Mot. AFN 002 001→ 8x</p>	<p>815.187 1 005 891 4x</p> 	<p>915.213 1 006 217</p> 	<p>a) 495.620 1 033 121</p>  <p>b) 878.070 M 14x1,5x16</p> <p>b) 115.100 95VW 6734AA 1 005 306 0 209 725 CU A 14x20x1,5</p>	<p>K:← 325.155 95VW 6700BA 1 004 928 ASW WD FPM/ACM 32x47x10</p> <p>K:→ 804.850 SP LD PTFE/ACM 85</p> <p>K:→ 342.093 95VW 6734AA 1 005 303 ASW LD FPM 85x105x11 →Mot. AFN 576 000</p> <p>K:→ 829.056 ASW LD FPM 85x105x11 →Mot. AFN 576 000</p> <p>N:← 325.155 95VW 6700BA 1 004 928 ASW WD FPM/ACM 32x47x10</p>	<p>TLS 703.980</p> 

FORD

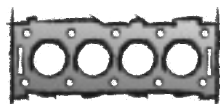
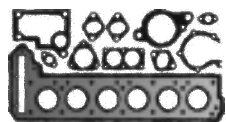

AHU
4 Cyl. **1896 ccm**
Cyl. 79,5 Ø
Galaxy TDI
03/1995 → 05/2006

ES⊕ **187.400**

CS* **670.720**
95VW 6013BA
1 004 926
→ Mot. AHU 390 000

CS* **375.540**
Mot. AHU 390 001 →

412.872
95VW 6051FA
1 079 766
1 005 254

0,910 mm →
1,000 mm
1,45 mm ± 80,5 Ø
1 ⊗

412.882
95VW 6051GA
1 079 767
1 005 258

1,010 mm →
1,100 mm
1,53 mm ± 80,5 Ø
2 ⊗

412.912
95VW 6051HA
1 079 768
1 005 261

1,110 mm →
1,200 mm
1,61 mm ± 80,5 Ø
3 ⊗

ZKS 819.824
M 12x1,75x115

ZKHS 470.280

619.771

915.017
3x

FE

915.009
1 005 264
3x

FE

ANU
4 Cyl. **1896 ccm**
Cyl. 79,5 Ø
Galaxy TDI
03/1995 → 05/2006

ES⊕ **330.340**

ES⊕ **428.880**
incl. VW 038 128 773

ES⊕ **655.360**

CS* **530.541**

150.153
1 106 825

0,910 mm →
1,000 mm
1,49 mm ± 80,5 Ø
1 ⊗

150.162
1 106 826

1,010 mm →
1,100 mm
1,57 mm ± 80,5 Ø
2 ⊗















150.172
1 106 827

1,110 mm →
1,200 mm
1,65 mm ± 80,5 Ø
3 ⊗

ZKS 057.240
1 100 655 (10x)
M 12x1,75x172

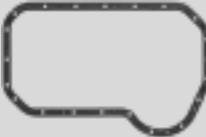
ZKHS 383.280

266.060
1 100 615

			<p>a) </p> <p>b) </p>	<p>K: </p> <p>N: </p>	
<p>VAS 825.042 FPM 701.289 95VW 6571BA 1 669 785 FPM 8x</p>	<p>815.187 1 005 891 4x</p> 	<p>915.213 1 006 217</p> 	<p>a) 495.620 1 033 121</p>  <p>b) 878.070 M 14x1,5x16</p> <p>b) 115.100 95VW 6734AA 1 005 306 0 209 725 CU A 14x20x1,5</p>	<p>K:← 325.155 95VW 6700BA 1 004 928 ASW WD FPM/ACM 32x47x10</p> <p>K:→ 804.850 SP LD PTFE/ACM 85</p> <p>K:→ 342.093 95VW 6734AA 1 005 303 ASW LD FPM 85x105x11 →Mot. AHU 390 000</p> <p>K:→ 829.056 ASW LD FPM 85x105x11 →Mot. AHU 390 000</p> <p>N:← 325.155 95VW 6700BA 1 004 928 ASW WD FPM/ACM 32x47x10</p>	<p>TLS 704.010</p> 
<p>VAS 825.042 FPM 701.289 95VW 6571BA 1 669 785 FPM 8x</p>	<p>625.760</p> 	<p>915.213 1 006 217</p> 	<p>a) 030.793 Dirko HT</p> <p>b) 567.640 1 459 212 M 14x1,5x22</p>	<p>K:← 155.560 1 100 691 ASW RD PTFE/ACM 35x48x10</p> <p>K:→ 012.370 1 100 575 IWD LD PTFE/ACM 85</p> <p>N:← 129.780 1 232 133 ASW RD PTFE/ACM 32x47x10</p>	<p>TLS 735.570</p> 

FORD

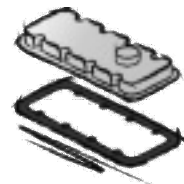
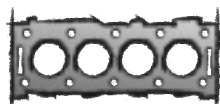
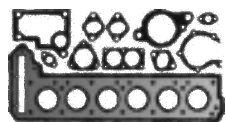

ASZ
4 Cyl. **1896 ccm**
Cyl. 79,5 Ø

Galaxy TDI
02/2003 → 05/2006

ES⊕ **655.360**



CS* **530.541**

150.153
1 106 825
0,910 mm
→
1,000 mm
1,49 mm $\frac{+}{-}$ 80,5 Ø
1 ⊗



150.162
1 106 826
1,010 mm
→
1,100 mm
1,57 mm $\frac{+}{-}$ 80,5 Ø
2 ⊗



150.172
1 106 827
1,110 mm
→
1,200 mm
1,65 mm $\frac{+}{-}$ 80,5 Ø
3 ⊗



ZKS 057.240
1 100 655 (10x)
M 12x1,75x172



ZKHS 726.290

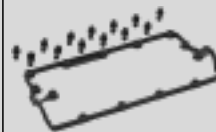

577.240

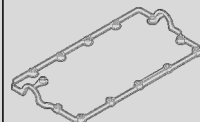

AUY
4 Cyl. **1896 ccm**
Cyl. 79,5 Ø

Galaxy TDI
04/2000 → 05/2006

ES⊕ **330.340**



ES⊕ **428.880**
incl. VW 038 128 773



CS* **530.541**

150.153
1 106 825
0,910 mm
→
1,000 mm
1,49 mm $\frac{+}{-}$ 80,5 Ø
1 ⊗



150.162
1 106 826
1,010 mm
→
1,100 mm
1,57 mm $\frac{+}{-}$ 80,5 Ø
2 ⊗

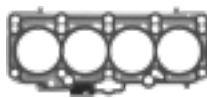

150.172
1 106 827
1,110 mm
→
1,200 mm
1,65 mm $\frac{+}{-}$ 80,5 Ø
3 ⊗



ZKS 057.240
1 100 655 (10x)
M 12x1,75x172

















ZKHS 383.280

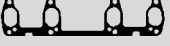

266.060
1 100 615



			<p>a) </p> <p>b) </p>	<p>K: </p> <p>N: </p>	
<p>VAS 825.042 FPM 701.289 95VW 6571BA 1 669 785 FPM 8x</p>	<p>625.760 </p>	<p>915.213 1 006 217 </p>	<p>a) 030.793 Dirko HT</p> <p>b) 567.640 1 459 212 M 14x1,5x22</p>	<p>K:← 155.560 1 100 691 ASW RD PTFE/ACM 35x48x10</p> <p>K:→ 012.370 1 100 575 IWD LD PTFE/ACM 85</p> <p>N:← 129.780 1 232 133 ASW RD PTFE/ACM 32x47x10</p>	<p>TLS 704.020 </p>
<p>VAS 825.042 FPM 701.289 95VW 6571BA 1 669 785 FPM 8x</p>	<p>049.930 </p>	<p>915.213 1 006 217 </p>	<p>a) 030.793 Dirko HT</p> <p>b) 567.640 1 459 212 M 14x1,5x22</p>	<p>K:← 155.560 1 100 691 ASW RD PTFE/ACM 35x48x10</p> <p>K:→ 012.370 1 100 575 IWD LD PTFE/ACM 85</p> <p>N:← 129.780 1 232 133 ASW RD PTFE/ACM 32x47x10</p>	<p>TLS 704.020 </p>

FORD

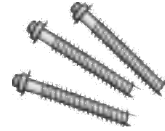
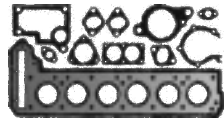

AVG

4 Cyl. **1896 ccm**
Cyl. 79,5 Ø

Galaxy TDI

08/1997 → 04/2000

ES⊕ **187.400**



CS* **375.540**



412.872

95VW 6051FA
1 079 766
1 005 254

0,910 mm
→
1,000 mm

1,45 mm $\frac{\pm}{\pm}$ 80,5 Ø
1 ⊗

412.882

95VW 6051GA
1 079 767
1 005 258

1,010 mm
→
1,100 mm

1,53 mm $\frac{\pm}{\pm}$ 80,5 Ø
2 ⊗

412.912

95VW 6051HA
1 079 768
1 005 261

1,110 mm
→
1,200 mm

1,61 mm $\frac{\pm}{\pm}$ 80,5 Ø
3 ⊗

ZKS **819.824**

M 12x1,75x115



ZKHS **470.280**



619.771

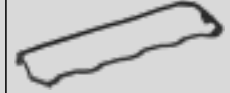

BTB

4 Cyl. **1896 ccm**
Cyl. 79,5 Ø

Galaxy TDI

05/2005 → 05/2006

ES⊕ **330.340**



ES⊕ **428.880**

incl. VW 038 128 773



ES⊕ **655.360**



CS* **720.420**

150.153

1 106 825

0,910 mm
→
1,000 mm

1,49 mm $\frac{\pm}{\pm}$ 80,5 Ø
1 ⊗

150.162

1 106 826

1,010 mm
→
1,100 mm

1,57 mm $\frac{\pm}{\pm}$ 80,5 Ø
2 ⊗

150.172

1 106 827

1,110 mm
→
1,200 mm

1,65 mm $\frac{\pm}{\pm}$ 80,5 Ø
3 ⊗

ZKS **057.510**

M 12x1,75x166

















ZKHS **383.280**

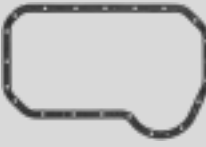

266.060

1 100 615



			<p>a) </p> <p>b) </p>	<p>K: </p> <p>N: </p>	
<p>VAS 825.042 FPM 701.289 95VW 6571BA 1 669 785 FPM 8x</p>	<p>815.187 1 005 891 4x</p> 	<p>915.213 1 006 217</p> 	<p>a) 030.793 Dirko HT</p> <p>a) 495.620 1 033 121</p>  <p>b) 878.070 M 14x1,5x16</p> <p>b) 115.100 95VW 6734AA 1 005 306 0 209 725 CU A 14x20x1,5</p>	<p>K:← 325.155 95VW 6700BA 1 004 928 ASW WD FPM/ACM 32x47x10</p> <p>K:→ 804.850 SP LD PTFE/ACM 85</p> <p>N:← 325.155 95VW 6700BA 1 004 928 ASW WD FPM/ACM 32x47x10</p>	<p>TLS 703.980</p> 
<p>VAS 825.042 FPM 701.289 95VW 6571BA 1 669 785 FPM 8x</p>	<p>625.760</p> 	<p>915.213 1 006 217</p> 	<p>a) 030.793 Dirko HT</p> <p>b) 567.640 1 459 212 M 14x1,5x22</p>	<p>K:← 155.560 1 100 691 ASW RD PTFE/ACM 35x48x10</p> <p>K:→ 012.370 1 100 575 IWD LD PTFE/ACM 85</p> <p>N:← 129.780 1 232 133 ASW RD PTFE/ACM 32x47x10</p>	<p>TLS 704.020</p> 

FORD

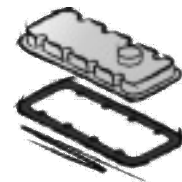
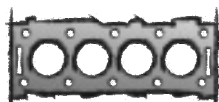
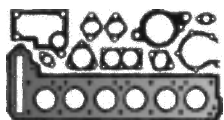

EDBA EDBB
EDBC EDBD
EDDB EDDC
EDDD EDDF

4 Cyl. 1988 ccm
Cyl. 84,8 Ø

Cougar
08/1998 → 12/2001

Focus
10/1998 → 05/2005

ES⊕ **338.730**
→04/1999
ES⊕ **338.720**
05/1999→
CS* **338.820**

123.483
XS7G 6051C1C
1 308 385
0,60 mm $\frac{2}{3}$ 86 Ø
02/1999→



ZKS **802.870**
1 024 355 (10x)
M 10x1,5x102

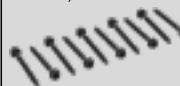

ZKHS **569.460**
→04/1999



ZKHS **389.060**
05/1999→



377.160
988M 6584AE
1 061 468
→04/1999

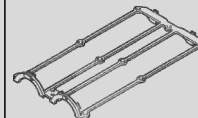

364.381
XS7G 6584AC
1 126 120
05/1999→

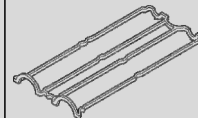

198.240
6 759 630
9x14x5
10x



HMDA
YF

4 Cyl. 1988 ccm
Cyl. 84,8 Ø

Focus
10/2002 → 11/2004

Maverick
02/2001 →

123.483
XS7G 6051C1C
1 308 385
0,60 mm $\frac{2}{3}$ 86 Ø



ZKS **802.870**
1 024 355 (10x)
M 10x1,5x102

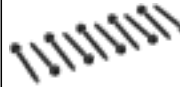

ZKHS **389.060**





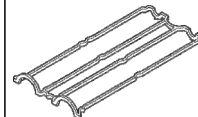











364.381
XS7G 6584AC
1 126 120



198.240
6 759 630
9x14x5
10x



			<p>a) </p> <p>b) </p>	<p>K: </p> <p>N: </p>	
<p>VAS 214.540 127.490 958M 6571BD 1 086 432 FPM 8x</p> <p>127.510 958M 6571CC 1 086 431 FPM 8x</p>	<p>267.701 968M 9448AA 1 053 902</p> 	<p>476.551 988M 9461AA 1 048 093 →09/1999 4x</p>  <p>364.071 XS7G 9461BA 1 090 949 10/1999→ 4x</p> 	<p>a) 036.164 Dirko HT / EU</p> <p>a) 510.031 Dirko HT / USA/CDN/MEX</p> <p>a) 527.291 Dirko HT / RU</p> <p>a) 648.661 Dirko HT / BR</p> <p>a) 388.160 988M 6710AG 1 078 707 ↑</p>  <p>b) 012.001 97JM 6730BA 1 013 938 M 14x1,5x20</p> <p>b) 176.090 97JM 6734BA 1 005 593 13x22,4x3</p>	<p>K:← 374.680 988M 6700A5B 1 102 415 ASW RD PTFE/ACM 35x50x7</p> <p>K:← 757.292 928M 6700B5A 6 165 500 ASW RD FPM 35x50x7</p> <p>K:→ 374.590 1M5G 6A321A5A 1 220 978 ASW LD PTFE/ACM 88x108x10</p> <p>K:→ 750.476 928M 6701B5A 6 126 179 ASW LD FPM 88x108x11</p> <p>N:← 467.860 928M 6K292B5B 1 067 029 AS OF RD FPM 42x53x7 2x</p>	
<p>VAS 214.540 127.490 958M 6571BD 1 086 432 FPM 8x</p> <p>127.510 958M 6571CC 1 086 431 FPM 8x</p>	<p>267.701 968M 9448AA 1 053 902</p> 	<p>364.071 XS7G 9461BA 1 090 949 4x</p> 	<p>a) 036.164 Dirko HT / EU</p> <p>a) 510.031 Dirko HT / USA/CDN/MEX</p> <p>a) 527.291 Dirko HT / RU</p> <p>a) 648.661 Dirko HT / BR</p> <p>a) 388.160 988M 6710AG 1 078 707 ↑</p>  <p>b) 012.001 97JM 6730BA 1 013 938 M 14x1,5x20</p> <p>b) 176.090 97JM 6734BA 1 005 593 13x22,4x3</p>	<p>K:← 374.680 988M 6700A5B 1 102 415 ASW RD PTFE/ACM 35x50x7</p> <p>K:→ 374.590 1M5G 6A321A5A 1 220 978 ASW LD PTFE/ACM 88x108x10</p> <p>N:← 467.860 928M 6K292B5B 1 067 029 AS OF RD FPM 42x53x7 2x</p>	

FORD

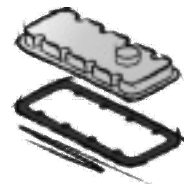
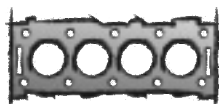
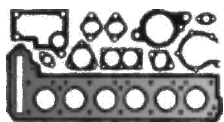

NGA **NGB**
NGC **NGD**

4 Cyl. **1988 ccm**
 Cyl. 84,8 Ø

Mondeo
 01/1993 → 09/2000

ES⊕ **458.591**
 938X 6014BA
 5 028 415
 →05/1998

ES⊕ **338.730**
 02/1999→
 →04/1999

ES⊕ **338.720**
 05/1999→

CS* **458.600**
 938X 6013AB
 5 031 032
 →05/1998

CS* **338.820**
 06/1998→

468.860
 938M 6051CE
 7 114 447
 1,75 mm $\frac{+}{-}$ 86,5 Ø
 →05/1998



123.483
 XS7G 6051C1C
 1 308 385
 0,60 mm $\frac{+}{-}$ 86 Ø
 01/1999→



ZKS **802.870**
 1 024 355 (10x)
 M 10x1,5x102

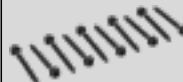

ZKHS **389.070**
 →05/1998



ZKHS **569.460**
 06/1998→
 →04/1999



ZKHS **389.060**
 05/1999→



458.660
 928M 6584C1B
 1 663 394
 →05/1998

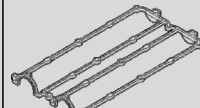

377.160
 988M 6584AE
 1 061 468
 05/1998→
 →04/1999

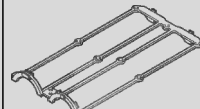



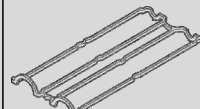













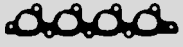







364.381
 XS7G 6584AC
 1 126 120
 05/1999→

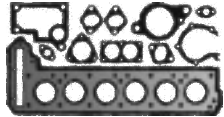
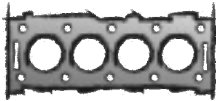

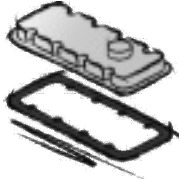



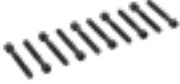

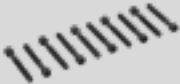
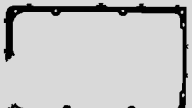













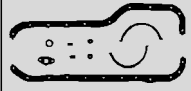
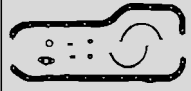







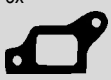





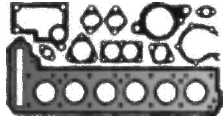
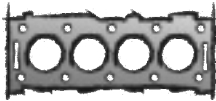

198.240
 6 759 630
 9x14x5
 10x

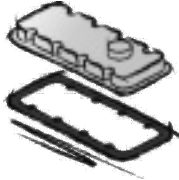

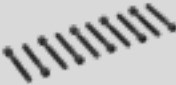

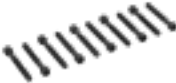















			<p>a) </p> <p>b) </p>	<p>K: </p> <p>N: </p>	
<p>VAS 214.540 127.490 958M 6571BD 1 086 432 FPM 8x</p> <p>127.510 958M 6571CC 1 086 431 FPM 8x</p>	<p>446.481 958M 9448AA 1 044 867</p>  <p>476.551 988M 9461AA 1 048 093 05/1998 → →09/1999 4x</p>  <p>364.071 XS7G 9461BA 1 090 949 10/1999 → 4x</p> 	<p>832.245 938M 9441DC 6 780 895 →05/1998</p>  <p>476.551 988M 9461AA 1 048 093 05/1998 → →09/1999 4x</p>  <p>364.071 XS7G 9461BA 1 090 949 10/1999 → 4x</p> 	<p>a) 467.830 938M 6710AC 7 008 824 →05/1998</p>  <p>a) 036.164 Dirko HT / EU 05/1998 →</p> <p>a) 510.031 Dirko HT / USA/CDN/MEX 05/1998 →</p> <p>a) 527.291 Dirko HT / RU 05/1998 →</p> <p>a) 648.661 Dirko HT / BR 05/1998 →</p> <p>a) 388.160 988M 6710AG 1 078 707 ↑</p>  <p>b) 012.001 97JM 6730BA 1 013 938 M 14x1,5x20</p> <p>b) 176.090 97JM 6734BA 1 005 593 13x22,4x3</p> <p>b) 786.500 928M 6734AA 1 454 118 Nylon A 14,5x22x2</p>	<p>K: ← 374.680 988M 6700A5B 1 102 415 ASW RD PTFE/ACM 35x50x7</p> <p>K: ← 757.292 928M 6700B5A 6 165 500 ASW RD FPM 35x50x7</p> <p>K: → 374.590 1M5G 6A321A5A 1 220 978 ASW LD PTFE/ACM 88x108x10</p> <p>K: → 750.476 928M 6701B5A 6 126 179 ASW LD FPM 88x108x11</p> <p>N: ← 467.860 928M 6K292B5B 1 067 029 AS OF RD FPM 42x53x7 2x</p>	

<p>FORD</p> 				
<p>NE NE1 NE3 NEE NEG OHC LC TL 20 LC</p> <p>4 Cyl. 1993 ccm Cyl. 90,8 Ø</p> <p>Consul 01/1972 → 12/1975</p> <p>Escort 03/1973 → 08/1980</p> <p>Granada 01/1975 → 07/1979</p> <p>Taunus 08/1973 → 07/1979</p>	<p>S⊕* 016.030 92HM 6008AA 5 027 036</p> <p>ES⊕ 016.049 93HX 6014AA 5 028 467 +92HM 6051AA +6 816 643 +1 663 371</p> <p>CS* 424.930 93HX 6013AA 5 028 466</p>	<p>834.182 92HM 6051AA 6 816 643 1,25 mm $\frac{1}{16}$ 92,7 Ø</p> 		<p>217.484 71HM 6584KA 6 078 807</p> 
<p>NER</p> <p>4 Cyl. 1993 ccm Cyl. 90,8 Ø</p> <p>Scorpio 10/1985 → 12/1990</p> <p>Taunus 07/1979 → 07/1982</p>	<p>S⊕* 016.030 92HM 6008AA 5 027 036</p> <p>ES⊕ 016.049 93HX 6014AA 5 028 467 +92HM 6051AA +6 816 643 +1 663 371</p> <p>CS* 424.930 93HX 6013AA 5 028 466</p>	<p>834.182 92HM 6051AA 6 816 643 1,25 mm $\frac{1}{16}$ 92,7 Ø</p> 	<p>ZKS 802.860 6 157 105 (10x) M 12x1,75x95</p> 	<p>217.484 71HM 6584KA 6 078 807</p> 
<p>C N6T N6TS NAE NAT NAV NAW NAX NE4 NE5 NEJ NEL NES NRC</p> <p>4 Cyl. 1993 ccm Cyl. 90,8 Ø</p> <p>P 100 10/1987 → 12/1992</p> <p>Scorpio 04/1985 → 12/1990</p> <p>Sierra 01/1987 → 02/1993</p> <p>Transit 09/1985 → 09/1992</p>	<p>ES⊕ 590.569 93HX 6014AB 5 028 468 +92HM 6051AA + 6 816 643</p> <p>CS* 424.930 93HX 6013AA 5 028 466</p>	<p>834.182 92HM 6051AA 6 816 643 1,25 mm $\frac{1}{16}$ 92,7 Ø</p> 	<p>ZKS 802.860 6 157 105 (10x) M 12x1,75x95</p> 	<p>764.248 85HM 6584BB 6 491 460</p> 

			<p>a) </p> <p>b) </p>	<p>K: </p> <p>N: </p>	
<p>206.954 70HM 6571A3B 1 490 525 ACM 8x</p> 	<p>646.540 92HM 9448AA 6 909 665 3x</p>  <p>646.550 92HM 9448BA 6 909 666 1x</p> 	<p>825.639 91HM 9441AB 6 763 409</p>  	<p>a) 193.713 92HM 6013AA 5 027 042</p>  <p>b) 786.500 928M 6734AA 1 454 118 Nylon A 14,5x22x2</p>	<p>K:← 757.497 86HM 6700AA 1 669 254 ASW RD FPM 42x56x7</p> <p>K:→ 550.680 1 032 209 ASW LD PTFE/FPM 79,33x95,28x11</p> <p>K:→ 763.713 86HM 6701A1A 1 641 893 AW/BS LD FPM 79,33x95,25x11</p> <p>N:← 757.497 86HM 6700AA 1 669 254 ASW RD FPM 42x56x7</p>	
<p>206.954 70HM 6571A3B 1 490 525 ACM 8x</p> 	<p>646.540 92HM 9448AA 6 909 665 3x</p>  <p>646.550 92HM 9448BA 6 909 666 1x</p> 	<p>825.639 91HM 9441AB 6 763 409</p>  	<p>a) 193.713 92HM 6013AA 5 027 042</p>  <p>b) 786.500 928M 6734AA 1 454 118 Nylon A 14,5x22x2</p>	<p>K:← 757.497 86HM 6700AA 1 669 254 ASW RD FPM 42x56x7</p> <p>K:→ 550.680 1 032 209 ASW LD PTFE/FPM 79,33x95,28x11</p> <p>K:→ 763.713 86HM 6701A1A 1 641 893 AW/BS LD FPM 79,33x95,25x11</p> <p>N:← 757.497 86HM 6700AA 1 669 254 ASW RD FPM 42x56x7</p>	
<p>206.954 70HM 6571A3B 1 490 525 ACM 8x</p> 	<p>646.540 92HM 9448AA 6 909 665 3x</p>  <p>646.550 92HM 9448BA 6 909 666 1x</p> 	<p>825.639 91HM 9441AB 6 763 409</p>  	<p>a) 193.713 92HM 6013AA 5 027 042</p>  <p>b) 786.500 928M 6734AA 1 454 118 Nylon A 14,5x22x2</p>	<p>K:← 757.497 86HM 6700AA 1 669 254 ASW RD FPM 42x56x7</p> <p>K:→ 550.680 1 032 209 ASW LD PTFE/FPM 79,33x95,28x11</p> <p>K:→ 763.713 86HM 6701A1A 1 641 893 AW/BS LD FPM 79,33x95,25x11</p> <p>N:← 757.497 86HM 6700AA 1 669 254 ASW RD FPM 42x56x7</p>	

<p>FORD</p> 				
<p>N4A N4B N4I NBA NCA NR2 NRA NRB NRD NRI</p> <p>4 Cyl. 1993 ccm Cyl. 90,8 Ø</p> <p>Scorpio 04/1985 → 09/1994</p> <p>Sierra 03/1985 → 02/1993</p> <p>Transit 04/1991 → 09/1994</p>	<p>S⊕* 590.577 ES⊕ 590.585 93HX 6014AC 5 028 469 +92HM 6051AA +6 816 643</p> <p>CS* 424.930 93HX 6013AA 5 028 466</p>	<p>834.182 92HM 6051AA 6 816 643 1,25 mm ± 92,7 Ø</p> 	<p>ZKS 802.860 6 157 105 (10x) M 12x1,75x95</p> 	<p>764.248 85HM 6584BB 6 491 460</p> 
<p>4RC NEK NEN NEP NET OHC TL 20 OHC TL 20 H/L TL20LNM</p> <p>4 Cyl. 1993 ccm Cyl. 90,8 Ø</p> <p>Capri 04/1974 → 12/1985</p> <p>Granada 08/1979 → 08/1985</p> <p>Sierra 08/1982 → 12/1986</p> <p>Taunus 08/1976 → 07/1979</p> <p>Transit 11/1977 → 10/1986</p>	<p>S⊕* 016.030 92HM 6008AA 5 027 036 →08/1983</p> <p>ES⊕ 016.049 93HX 6014AA 5 028 467 +92HM 6051AA +6 816 643 +1 663 371 →08/1983</p> <p>ES⊕ 590.569 93HX 6014AB 5 028 468 +92HM 6051AA + 6 816 643 08/1983→</p> <p>CS* 424.930 93HX 6013AA 5 028 466</p>	<p>834.182 92HM 6051AA 6 816 643 1,25 mm ± 92,7 Ø</p> 	<p>ZKS 802.860 6 157 105 (10x) M 12x1,75x95 08/1983→</p> 	<p>217.484 71HM 6584KA 6 078 807 →08/1983</p>  <p>764.248 85HM 6584BB 6 491 460 08/1983→</p> 
<p>BCCC BCCD BCDA YLCB YLCC YLDA YLDC YMCA YMCB YMCC YMDAYNCA</p> <p>4 Cyl. 1995 ccm Cyl. 84,0 Ø</p> <p>Focus 01/2018 →</p> <p>Galaxy 07/2018 →</p> <p>Kuga 07/2019 →</p> <p>Mondeo 01/2019 →</p> <p>S-Max 07/2018 →</p>	<p>ES⊕ 806.850</p>  <p>OKS 840.980 2269740</p> 		<p>ZKS 806.710</p>	<p>355.792 GK2Q6L090BB 2100953</p>

			<p>a) </p> <p>b) </p>	<p>K: </p> <p>N: </p>	
<p>206.954 70HM 6571A3B 1 490 525 ACM 8x</p> 	<p>646.540 92HM 9448AA 6 909 665 3x</p>  <p>646.550 92HM 9448BA 6 909 666 1x</p> 	<p>825.612 91HM 9441BB 6 763 410</p> 	<p>a) 193.713 92HM 6013AA 5 027 042</p>  <p>b) 786.500 928M 6734AA 1 454 118 Nylon A 14,5x22x2</p>	<p>K:← 757.497 86HM 6700AA 1 669 254 ASW RD FPM 42x56x7</p> <p>K:→ 550.680 1 032 209 ASW LD PTFE/FPM 79,33x95,28x11</p> <p>K:→ 763.713 86HM 6701A1A 1 641 893 AW/BS LD FPM 79,33x95,25x11</p> <p>N:← 757.497 86HM 6700AA 1 669 254 ASW RD FPM 42x56x7</p>	
<p>206.954 70HM 6571A3B 1 490 525 ACM 8x</p> 	<p>646.540 92HM 9448AA 6 909 665 3x</p>  <p>646.550 92HM 9448BA 6 909 666 1x</p> 	<p>825.639 91HM 9441AB 6 763 409</p> 	<p>a) 193.713 92HM 6013AA 5 027 042</p>  <p>b) 786.500 928M 6734AA 1 454 118 Nylon A 14,5x22x2</p>	<p>K:← 757.497 86HM 6700AA 1 669 254 ASW RD FPM 42x56x7</p> <p>K:→ 550.680 1 032 209 ASW LD PTFE/FPM 79,33x95,28x11</p> <p>K:→ 763.713 86HM 6701A1A 1 641 893 AW/BS LD FPM 79,33x95,25x11</p> <p>N:← 757.497 86HM 6700AA 1 669 254 ASW RD FPM 42x56x7</p>	
			<p>a) 036.164 Dirko HT / EU</p> <p>a) 510.031 Dirko HT / USA/CDN/MEX</p> <p>a) 527.291 Dirko HT / RU</p> <p>a) 648.661 Dirko HT / BR</p> <p>b) 012.001 97JM 6730BA 1 013 938 M 14x1,5x20</p> <p>b) 176.090 97JM 6734BA 1 005 593 13x22,4x3</p>	<p>K:← 841.200 2 089 587 AW/BS OF RD FPM 48x64x8</p> <p>K:← 855.670 2 089 587 A/B OF RD FPM 48x64x8</p>	

FORD

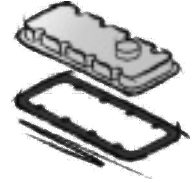
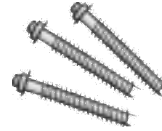
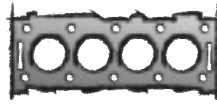
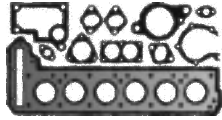

BCFA **BCFB**
BCFC **BCFD**
BCRA **BCRB**
BJFA **BJFB**
BJFC **BJFD**
BJRA **BJRB**
BKFA **BKFB**
BKFC **BKFD**
BKRA **BKRB**
BLFA **BLFB**
BLFC **BLFD**
BLHA **BLRA**
BLRB **P0FA**
P0FB **YLF6**
YLFA **YLF6**
YLFS **YLR6**
YLRA **YMF6**
YMFA **YMF6**
YMFS **YMFB**
YMRA **YMHA**
YMR6 **YMRA**
YNF6 **YNFA**
YNFB **YNFS**
YNHA **YNR6**
YNRA

4 Cyl. 1995 ccm
Cyl. 84,0 Ø

Tourneo
 05/2019 →
Tourneo TDCi
 12/2015 →
Transit
 12/2015 →
Transit TDCi
 03/2016 →

ES⊕ **806.850**











OKS **841.060**
2025840

ZKS **806.710**

355.792
GK2Q6L090BB
2100953

FORD

			<p>a) </p> <p>b) </p>	<p>K: </p> <p>N: </p>	
			<p>a) 036.164 Dirko HT / EU</p> <p>a) 510.031 Dirko HT / USA/CDN/MEX</p> <p>a) 527.291 Dirko HT / RU</p> <p>a) 648.661 Dirko HT / BR</p> <p>b) 012.001 97JM 6730BA 1 013 938 M 14x1,5x20</p> <p>b) 176.090 97JM 6734BA 1 005 593 13x22,4x3</p>	<p>K:← 841.200 2 089 587 AW/BS OF RD FPM 48x64x8</p> <p>K:← 855.670 2 089 587 A/B OF RD FPM 48x64x8</p>	

FORD

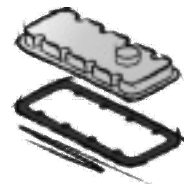
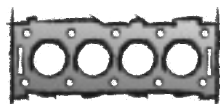
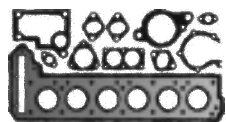

AZBA **AZBC**
AZWA **AZWC**
G6DA **G6DB**
G6DC **G6DD**
G6DE **G6DF**
G6DG **KLBA**
LPBA **QXBA**
QXBB **QXWA**
QXWB **QXWC**

4 Cyl. 1997 ccm
Cyl. 85,0 Ø

C-Max TDCi
 02/2007 → 09/2010
Focus C-Max TDCi
 10/2003 → 03/2007
Focus TDCi
 07/2004 → 09/2012
Galaxy TDCi
 05/2006 → 06/2015
Kuga TDCi
 03/2008 → 11/2012
Mondeo TDCi
 03/2007 → 01/2015
S-Max TDCi
 05/2006 → 12/2014

S⊕* 527.660



ES⊕ 527.550

135.052

3M5Q 6051FB
1 313 813

0,550 mm
 →
 0,600 mm

1,25 mm $\frac{\pm}{\pm}$ 86 Ø
 1 ⊗



153.002

3M5Q 6051GB
1 313 814

0,610 mm
 →
 0,650 mm

1,30 mm $\frac{\pm}{\pm}$ 86 Ø
 2 ⊗



153.142

3M5Q 6051HB
1 313 815

0,660 mm
 →
 0,710 mm

1,35 mm $\frac{\pm}{\pm}$ 86 Ø
 3 ⊗



135.072

3M5Q 6051JB
1 313 816

0,710 mm
 →
 0,750 mm

1,40 mm $\frac{\pm}{\pm}$ 86 Ø
 4 ⊗



ZKS 267.551



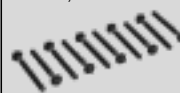







1 792 821 (10x)
 1 445 927 (10x)
 M 12x1,5x121











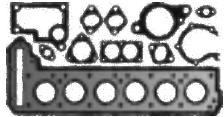
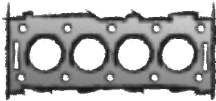

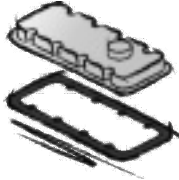







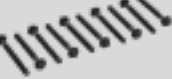



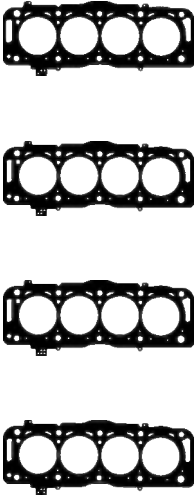
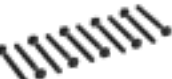
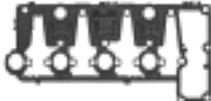



ZKHS 540.540

3M5Q 6L004CA
 1 365 586



			<p>a) </p> <p>b) </p>	<p>K: </p> <p>N: </p>	
<p>VAS 155.740 FPM 2x</p> <p>136.940 3M5Q 6571BA 1 231 935 FPM 16x</p>	<p>156.770 3M5Q 9448AA 1 234 178</p> 	<p>AAS 540.540 3M5Q 6L004CA 1 365 586</p> 	<p>a) 036.164 Dirko HT / EU</p> <p>a) 510.031 Dirko HT / USA/CDN/MEX</p> <p>a) 527.291 Dirko HT / RU</p> <p>a) 648.661 Dirko HT / BR</p> <p>b) 877.900 M 14x1,25x12</p> <p>b) 394.290 3M5Q 6734AA 1 250 324 CU C 14x21x2</p>	<p>K:← 393.990 3M5Q 6700BC 1 350 608 ASW RD PTFE/ACM 42x62x7</p> <p>K:← 508.233 3M5Q 6700BB 1 313 822 ASW RD FPM/ACM 42x62x7</p> <p>K:→ 394.012 ASW LD PTFE/ACM 90x110x8</p> <p>K:→ 508.209 3M5Q 6701BB 1 313 821 ASW LD FPM/ACM 90x110x7</p> <p>N:← 153.740 3M5Q 6L270BA 1 231 972 ASW RD FPM 27x47x7</p>	<p>TLS 714.640</p> 

FORD						
<p>T7CA T7CC T7CD T7CE T7CF T7CI T7CJ T7CK T7CL T7CN T7CP T7CQ T7DA T7DB T7DC T7DD T7MA T7MB T7MC T7MD T8CA T8CB T8CC T8CD T8CG T8CH T8CI T8CJ T8CL T8DA T8DE T8MA T8MB T8MC T9CA T9CB T9CC T9CD UFCA UFCB UFCD XRMA XRMB XRMC</p> <p>4 Cyl. 1997 ccm Cyl. 85,0 Ø</p> <p>C-Max TDCi 03/2015 → 06/2019</p> <p>Focus TDCi 11/2014 →</p> <p>Galaxy TDCi 01/2015 → 06/2018</p> <p>Grand C-Max TDCi 03/2015 → 06/2019</p> <p>Kuga TDCi 09/2014 →</p> <p>Mondeo TDCi 09/2014 →</p> <p>S-Max TDCi 01/2015 → 06/2018</p>	<p>S⊕* 928.970 </p> <p>ES⊕ 884.220 </p> <p>CS* 868.260 OKS 868.220</p>	<p>228.512  0,450 mm → 0,500 mm 1,25 mm $\frac{\pm}{\pm}$ 86,5 Ø 1 ⊗</p> <p>228.522  0,500 mm → 0,550 mm 1,30 mm $\frac{\pm}{\pm}$ 86,5 Ø 2 ⊗</p> <p>228.532  0,550 mm → 0,600 mm 1,35 mm $\frac{\pm}{\pm}$ 86,5 Ø 3 ⊗</p> <p>228.542  0,600 mm → 0,650 mm 1,40 mm $\frac{\pm}{\pm}$ 86,5 Ø 4 ⊗</p> <p>964.581  0,650 mm → 0,700 mm 1,45 mm $\frac{\pm}{\pm}$ 86,5 Ø 2 ⊗</p>	<p>ZKS 267.551 1 792 821 (10x) 1 445 927 (10x) M 12x1,5x121</p> 	<p>793.570 DS7Q-9R535-CA 1 887 374</p> <p>656.350 DS7Q-9625-BA 1 861 747</p> 		
<p>TXBA TXBB TXDA TXDB TXMA TXWA TYBA TYDA TYMA TYWA UFBA UFBB UFDA UFDB UFMA UFWA UKBA UKBB UKDA UKDB UKMA UKWA</p> <p>4 Cyl. 1997 ccm Cyl. 85,0 Ø</p> <p>C-Max TDCi 04/2010 → 06/2019</p> <p>Focus TDCi 07/2010 →</p> <p>Galaxy TDCi 05/2006 → 06/2015</p> <p>Grand C-Max TDCi 12/2010 → 06/2019</p> <p>Kuga TDCi 03/2008 →</p> <p>Mondeo TDCi 03/2007 → 01/2015</p> <p>S-Max TDCi 05/2006 → 12/2014</p>	<p>S⊕* 587.250 </p> <p>ES⊕ 587.150 </p> <p>CS* 572.860</p>	<p>442.802 9M5Q-6051AA 1 683 687 1,25 mm $\frac{\pm}{\pm}$ 85,8 Ø 1 ⊗</p> <p>442.812 9M5Q-6051BA 1 683 688 1,30 mm $\frac{\pm}{\pm}$ 85,8 Ø 2 ⊗</p> <p>442.822 9M5Q-6051CA 1 683 689 1,35 mm $\frac{\pm}{\pm}$ 85,8 Ø 3 ⊗</p> <p>442.832 9M5Q-6051DA 1 683 690 1,40 mm $\frac{\pm}{\pm}$ 85,8 Ø 2 ⊗</p> 	<p>ZKS 267.551 1 792 821 (10x) 1 445 927 (10x) M 12x1,5x121</p> 	<p>453.500 9M5Q-6L004AA 1 714 919</p> 		

			<p>a) </p> <p>b) </p>	<p>K: </p> <p>N: </p>	
<p>VAS 453.750 FPM</p>	<p>750.931 DS7Q-9448-CB 1 876 012</p>		<p>a) 036.164 Dirko HT / EU</p> <p>a) 510.031 Dirko HT / USA/CDN/MEX</p> <p>a) 527.291 Dirko HT / RU</p> <p>a) 648.661 Dirko HT / BR</p> <p>a) 792.230 DS7Q 6710AA 1 904 587</p>  <p>b) 821.290 DS7Q-6730-AA 1 871 598</p> <p>b) 163.480 ACM RD 30x37</p>	<p>K:← 393.990 3M5Q 6700BC 1 350 608 ASW RD PTFE/ACM 42x62x7</p> <p>K:→ 394.012 ASW LD PTFE/ACM 90x110x8</p> <p>N:← 153.740 3M5Q 6L270BA 1 231 972 ASW RD FPM 27x47x7</p>	<p>TLS 884.230</p> 
<p>VAS 453.750 FPM</p>	<p>521.960 9M5Q-9448-AA 1 681 988</p> 		<p>a) 036.164 Dirko HT / EU</p> <p>a) 510.031 Dirko HT / USA/CDN/MEX</p> <p>a) 527.291 Dirko HT / RU</p> <p>a) 648.661 Dirko HT / BR</p> <p>b) 877.930 incl. 108.502 M 10x1,25x13</p> <p>b) 108.502 2S6Q 6734AA 1 145 962 CU A 10x21x2,1</p>	<p>K:← 393.990 3M5Q 6700BC 1 350 608 ASW RD PTFE/ACM 42x62x7</p> <p>K:→ 394.012 ASW LD PTFE/ACM 90x110x8</p> <p>N:← 153.740 3M5Q 6L270BA 1 231 972 ASW RD FPM 27x47x7</p>	<p>TLS 953.630</p>

FORD

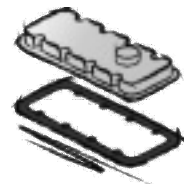
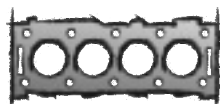
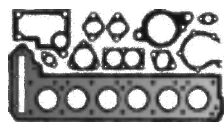

ABFA D3FA
F3FA

4 Cyl. 1998 ccm
Cyl. 86,0 Ø

Transit DI
08/2000 → 05/2006
Transit Tourneo DI
06/2000 → 03/2005
Transit Tourneo TDCi
06/2000 → 08/2003

ES⊕ **030.612**
incl. 026.990

CS* **030.551**

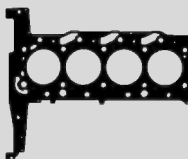
265.371
5S7Q 6051AA
1 349 880
 0,430 mm
→
0,520 mm
1,10 mm $\frac{\pm}{\pm}$ 87,1 Ø
1 ▽

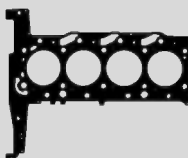

265.381
5S7Q 6051BA
1 349 890
 0,521 mm
→
0,570 mm
1,15 mm $\frac{\pm}{\pm}$ 87,1 Ø
2 ▽



265.391
5S7Q 6051CA
1 349 899
 0,571 mm
→
0,620 mm
1,20 mm $\frac{\pm}{\pm}$ 87,1 Ø
3 ▽

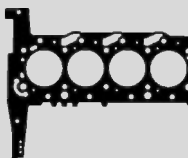

ZKS 175.580
1 102 676 (8x)
+1 102 674 (10x)
M 10x1,5x160 M
8x1,25x121



ZKHS 389.080



027.720
6C1Q 6K260AA
1 372 490

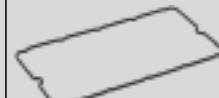

569.770
YC1Q 6K780BB
1 121 656
4x

389.140
12x

D5BA
SDBA

4 Cyl. 1998 ccm
Cyl. 86,0 Ø

Mondeo TDDi/TDCi
10/2000 → 03/2007

ES⊕ **030.612**
incl. 026.990

CS* **030.551**

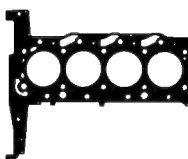
265.371
5S7Q 6051AA
1 349 880
 0,430 mm
→
0,520 mm
1,10 mm $\frac{\pm}{\pm}$ 87,1 Ø
1 ▽

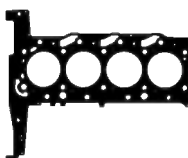

265.381
5S7Q 6051BA
1 349 890
 0,521 mm
→
0,570 mm
1,15 mm $\frac{\pm}{\pm}$ 87,1 Ø
2 ▽



265.391
5S7Q 6051CA
1 349 899
 0,571 mm
→
0,620 mm
1,20 mm $\frac{\pm}{\pm}$ 87,1 Ø
3 ▽

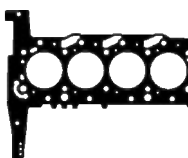

ZKS 175.580
1 102 676 (8x)
+1 102 674 (10x)
M 10x1,5x160 M
8x1,25x121



ZKHS 389.080





















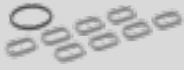



027.720
6C1Q 6K260AA
1 372 490



569.770
YC1Q 6K780BB
1 121 656
4x

389.140
12x

			<p>a) </p> <p>b) </p>	<p>K: </p> <p>N: </p>	
<p>027.740 XS7Q 6571AD 1 357 589 FPM 16x</p> 	<p>026.961 2S7Q 9448BA 1 137 860 →05/2002</p>  <p>026.990 1 360 565 05/2002→</p> 	<p>AAS 052.110 →05/2003</p>  <p>AAS 280.350 05/2003→</p>  <p>027.150 XS7Q 8565AA 1 138 392 8x</p> 	<p>a) OWS 027.371 3S7Q 6710BA 1 498 320</p>  <p>a) 036.164 Dirko HT / EU ↓ a) 510.031 Dirko HT / USA/CDN/MEX ↓ a) 527.291 Dirko HT / RU ↓ a) 648.661 Dirko HT / BR ↓ b) 012.001 97JM 6730BA 1 013 938 M 14x1,5x20 b) 176.090 97JM 6734BA 1 005 593 13x22,4x3</p>	<p>K:← 026.782 1 801 837 ASW RD PTFE 50x90x14</p> <p>K:→ 026.812 3S7Q 6385AB 1 684 287 IWD LD PTFE/ACM 106x215</p> <p>N:← 903.600 1 139 357 ASW LD PTFE/ACM 36x50x7</p>	
<p>027.740 XS7Q 6571AD 1 357 589 FPM 16x</p> 	<p>026.961 2S7Q 9448BA 1 137 860 →05/2002</p>  <p>026.990 1 360 565 05/2002→</p> 	<p>AAS 052.110 →05/2003</p>  <p>AAS 280.350 05/2003→</p>  <p>027.150 XS7Q 8565AA 1 138 392 8x</p> 	<p>a) OWS 027.371 3S7Q 6710BA 1 498 320</p>  <p>a) 036.164 Dirko HT / EU ↓ a) 510.031 Dirko HT / USA/CDN/MEX ↓ a) 527.291 Dirko HT / RU ↓ a) 648.661 Dirko HT / BR ↓ b) 012.001 97JM 6730BA 1 013 938 M 14x1,5x20 b) 176.090 97JM 6734BA 1 005 593 13x22,4x3</p>	<p>K:← 026.782 1 801 837 ASW RD PTFE 50x90x14</p> <p>K:→ 026.812 3S7Q 6385AB 1 684 287 IWD LD PTFE/ACM 106x215</p> <p>N:← 903.600 1 139 357 ASW LD PTFE/ACM 36x50x7</p>	<p>TLS 734.820 →05/2002</p>  <p>TLS 734.830 incl. 026.990 05/2002→</p> 

FORD

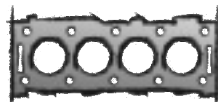
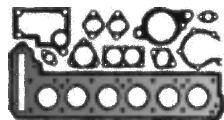

FIFA
4 Cyl. 1998 ccm
Cyl. 86,0 Ø

Transit TDCi
08/2002 → 05/2006
Transit Tourneo TDCi
03/2002 → 03/2006

ES⊕ **030.602**

CS* **030.551**

265.371
5S7Q 6051AA
1 349 880
 0,430 mm
→
0,520 mm
1,10 mm ± 87,1 Ø
1 ▽

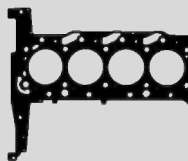

265.381
5S7Q 6051BA
1 349 890
 0,521 mm
→
0,570 mm
1,15 mm ± 87,1 Ø
2 ▽

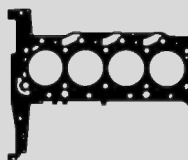

265.391
5S7Q 6051CA
1 349 899
 0,571 mm
→
0,620 mm
1,20 mm ± 87,1 Ø
3 ▽

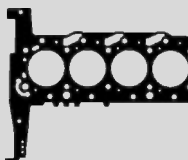

ZKS 175.580
1 102 676 (8x)
+1 102 674 (10x)
M 10x1,5x160 M
8x1,25x121



ZKHS 389.080



027.720
6C1Q 6K260AA
1 372 490





569.770
YC1Q 6K780BB
1 121 656
4x

389.140
12x

D6BA HJBA
HJBB HJBC
4 Cyl. 1998 ccm
Cyl. 86,0 Ø

Mondeo TDDi/TDCi
10/2000 → 03/2007

ES⊕ **030.583**
incl. 026.980

ES⊕ **030.612**
incl. 026.990

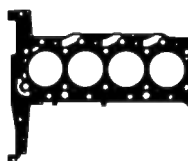
CS* **030.551**

265.371
5S7Q 6051AA
1 349 880
 0,430 mm
→
0,520 mm
1,10 mm ± 87,1 Ø
1 ▽

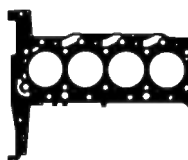

265.381
5S7Q 6051BA
1 349 890
 0,521 mm
→
0,570 mm
1,15 mm ± 87,1 Ø
2 ▽



265.391
5S7Q 6051CA
1 349 899
 0,571 mm
→
0,620 mm
1,20 mm ± 87,1 Ø
3 ▽

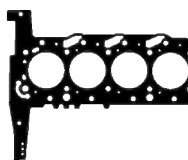

ZKS 175.580
1 102 676 (8x)
+1 102 674 (10x)
M 10x1,5x160 M
8x1,25x121



ZKHS 389.080















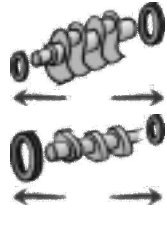



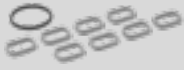
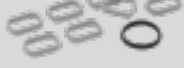



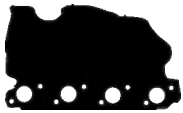

027.720
6C1Q 6K260AA
1 372 490



569.770
YC1Q 6K780BB
1 121 656
4x

389.140
12x

			<p>a) </p> <p>b) </p>	<p>K: </p> <p>N: </p>	
<p>027.740 XS7Q 6571AD 1 357 589 FPM 16x</p> 	<p>026.980 2S7Q 9448 CB 1 360 555</p> 	<p>AAS 052.110 →05/2003</p>  <p>AAS 280.350 05/2003→</p>  <p>027.150 XS7Q 8565AA 1 138 392 8x</p> 	<p>a) OWS 027.371 3S7Q 6710BA 1 498 320</p>  <p>a) 036.164 Dirko HT / EU ↓ a) 510.031 Dirko HT / USA/CDN/MEX ↓ a) 527.291 Dirko HT / RU ↓ a) 648.661 Dirko HT / BR ↓ b) 012.001 97JM 6730BA 1 013 938 M 14x1,5x20 b) 176.090 97JM 6734BA 1 005 593 13x22,4x3</p>	<p>K:← 026.782 1 801 837 ASW RD PTFE 50x90x14</p> <p>K:→ 026.812 3S7Q 6385AB 1 684 287 IWD LD PTFE/ACM 106x215</p> <p>N:← 903.600 1 139 357 ASW LD PTFE/ACM 36x50x7</p>	<p>TLS 733.570 incl. 026.980</p> 
<p>027.740 XS7Q 6571AD 1 357 589 FPM 16x</p> 	<p>026.961 2S7Q 9448BA 1 137 860 →05/2002</p>  <p>026.980 2S7Q 9448 CB 1 360 555 05/2002→</p>  <p>026.990 1 360 565 05/2002→</p> 	<p>AAS 052.110 →05/2003</p>  <p>AAS 280.350 05/2003→</p>  <p>027.150 XS7Q 8565AA 1 138 392 8x</p> 	<p>a) OWS 027.371 3S7Q 6710BA 1 498 320</p>  <p>a) 036.164 Dirko HT / EU ↓ a) 510.031 Dirko HT / USA/CDN/MEX ↓ a) 527.291 Dirko HT / RU ↓ a) 648.661 Dirko HT / BR ↓ b) 012.001 97JM 6730BA 1 013 938 M 14x1,5x20 b) 176.090 97JM 6734BA 1 005 593 13x22,4x3</p>	<p>K:← 026.782 1 801 837 ASW RD PTFE 50x90x14</p> <p>K:→ 026.812 3S7Q 6385AB 1 684 287 IWD LD PTFE/ACM 106x215</p> <p>N:← 903.600 1 139 357 ASW LD PTFE/ACM 36x50x7</p>	<p>TLS 734.820 →05/2002</p>  <p>TLS 734.830 incl. 026.990 05/2002→</p> 

FORD

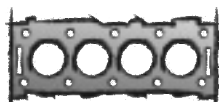
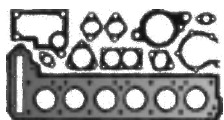

FMBA N7BA
PD20FMCR

4 Cyl. **1998 ccm**
Cyl. 86,0 Ø

Mondeo TDCi
10/2000 → 03/2007

ES⊕ **030.583**
incl. 026.980



CS* **030.551**

265.371
5S7Q 6051AA
1 349 880
 0,430 mm
→
0,520 mm
1,10 mm $\frac{\pm}{\pm}$ 87,1 Ø
1 ∇

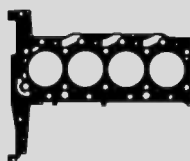

265.381
5S7Q 6051BA
1 349 890
 0,521 mm
→
0,570 mm
1,15 mm $\frac{\pm}{\pm}$ 87,1 Ø
2 ∇

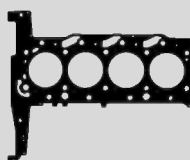

265.391
5S7Q 6051CA
1 349 899
 0,571 mm
→
0,620 mm
1,20 mm $\frac{\pm}{\pm}$ 87,1 Ø
3 ∇

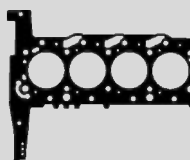

ZKS 175.580
1 102 676 (8x)
+1 102 674 (10x)
M 10x1,5x160 M
8x1,25x121



ZKHS 459.860
→11/2002
ZKHS 389.080
11/2002→



027.720
6C1Q 6K260AA
1 372 490

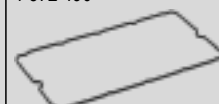

569.770
YC1Q 6K780BB
1 121 656
11/2002→
4x

389.140
12x

NSE
ZVSA

4 Cyl. **1998 ccm**
Cyl. 86,0 Ø

Galaxy
11/1995 → 05/2006

520.890
95WM-6051C4A
7 116 165
87 Ø

ZKS 802.900
1 073 369 (10x)
M 11x1,5x173

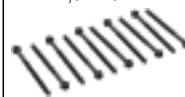

446.260
95WM 6584AC
7 024 740



C20HDEX

4 Cyl. **1999 ccm**
Cyl. 87,5 Ø

Focus
04/2011 →
Tourneo Connect
09/2009 → 12/2013
Transit Connect
09/2009 →

CS* **781.240**























255.070
1S7G 6051AJ
1 229 872
0,50 mm $\frac{\pm}{\pm}$ 89 Ø











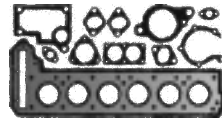
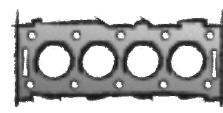

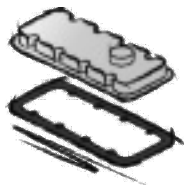

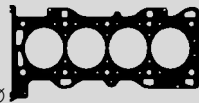





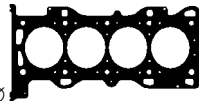

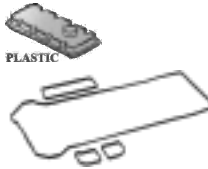











ZKHS 771.310
CM5E-6D271-AA
5 143 612









709.690
BR3E-6P251-BA
5 053 748
↑

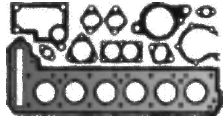
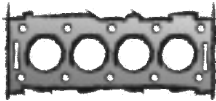

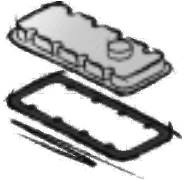





















			<p>a) </p> <p>b) </p>	<p>K: </p> <p>N: </p>	
<p>027.740 XS7Q 6571AD 1 357 589 FPM 16x</p> 	<p>026.961 2S7Q 9448BA 1 137 860 →05/2002</p>  <p>026.980 2S7Q 9448 CB 1 360 555 05/2002→</p> 	<p>AAS 052.110 →05/2003</p>  <p>AAS 280.350 05/2003→</p>  <p>027.150 XS7Q 8565AA 1 138 392 8x</p> 	<p>a) OWS 027.371 3S7Q 6710BA 1 498 320</p>  <p>a) 036.164 Dirko HT / EU ↓ a) 510.031 Dirko HT / USA/CDN/MEX ↓ a) 527.291 Dirko HT / RU ↓ a) 648.661 Dirko HT / BR ↓ b) 012.001 97JM 6730BA 1 013 938 M 14x1,5x20 b) 176.090 97JM 6734BA 1 005 593 13x22,4x3</p>	<p>K:← 026.782 1 801 837 ASW RD PTFE 50x90x14</p> <p>K:→ 026.812 3S7Q 6385AB 1 684 287 IWD LD PTFE/ACM 106x215</p> <p>N:← 903.600 1 139 357 ASW LD PTFE/ACM 36x50x7</p>	<p>TLS 734.820 →05/2002</p>  <p>TLS 733.570 incl. 026.980 05/2002→</p> 
<p>766.615 88WM 6571A2A 6 166 533 FPM 8x</p>	<p>050.380 95WM 9448C2A 7 087 453 2x</p> 	<p>AAS 388.260 7 165 130 +7 279 840 (4x)</p>  <p>050.460 95WM 9461EA 7 279 840 4x</p> 	<p>b) 786.500 928M 6734AA 1 454 118 Nylon A 14,5x22x2</p>	<p>K:← 757.497 86HM 6700AA 1 669 254 ASW RD FPM 42x56x7</p> <p>K:→ 374.590 1M5G 6A321A5A 1 220 978 ASW LD PTFE/ACM 88x108x10</p> <p>K:→ 750.476 928M 6701B5A 6 126 179 ASW LD FPM 88x108x11</p> <p>N:← 757.292 928M 6700B5A 6 165 500 ASW RD FPM 35x50x7</p>	
<p>026.680 3S4G 6A517AA 1 151 825 FPM E 8x</p>  <p>026.650 1S7G 6A517BG 1 206 655 FPM A 8x</p> 	<p>771.330 BV61-9448-AD 5 192 589</p>	<p>771.320 CM5E-9439-AA 5 112 231 4x</p>	<p>a) 036.164 Dirko HT / EU</p> <p>a) 510.031 Dirko HT / USA/CDN/MEX</p> <p>a) 527.291 Dirko HT / RU</p> <p>a) 648.661 Dirko HT / BR</p> <p>b) 012.001 97JM 6730BA 1 013 938 M 14x1,5x20</p> <p>b) 176.090 97JM 6734BA 1 005 593 13x22,4x3</p>	<p>K:← 023.631 1S7G 6700AC 1 119 162 AS RD FPM 37x50x6</p> <p>K:← 649.250 CM5E-6700-AB AS OF RD FPM 37x50x6</p> <p>K:→ 023.940 1S7G 6A321AA 1 211 759 IWD LD PTFE 88x180x15</p>	

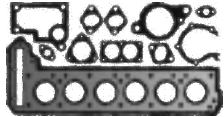
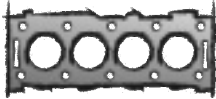

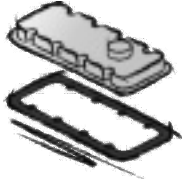









<p>FORD</p> 				
<p>CJBA CJBB ZH20CJBB</p> <p>4 Cyl. 1999 ccm Cyl. 87,5 Ø</p> <p>Metrostar 10/2000 → 02/2007</p> <p>Mondeo 10/2000 → 03/2007</p>	<p>ES⊕ 027.470</p>  <p>CS* 027.291</p>	<p>255.070 1S7G 6051AJ 1 229 872 0,50 mm $\frac{2}{3}$ 89 Ø</p> 	<p>ZKS 028.230 1 229 267 (10x) M 10x1,25x145,5</p> 	<p>ZKHS 026.551 1S7G 6584AE 1 119 878</p>  <p>AL</p>  <p>ZKHS 001.563 1S7G 6K260AA 1 220 025</p> <p>PLASTIC</p> 
<p>AOBA AOBC AODA AODB AODE AOWA AOWB N4JB SYDA TBBA TBBB TBWA TBWB</p> <p>4 Cyl. 1999 ccm Cyl. 87,5 Ø</p> <p>C-Max 02/2007 → 09/2010</p> <p>Fiesta 03/2005 → 06/2008</p> <p>Focus 07/2004 → 09/2013</p> <p>Focus C-Max 03/2004 → 03/2007</p> <p>Galaxy 05/2006 → 06/2015</p> <p>Mondeo 03/2007 → 01/2015</p> <p>S-Max 05/2006 → 12/2014</p>	<p>ES⊕ 027.470</p>  <p>CS* 027.291</p>	<p>255.070 1S7G 6051AJ 1 229 872 0,50 mm $\frac{2}{3}$ 89 Ø</p> 	<p>ZKS 028.230 1 229 267 (10x) M 10x1,25x145,5</p> 	<p>ZKHS 001.563 1S7G 6K260AA 1 220 025</p> <p>PLASTIC</p> 
<p>R9CB R9CD R9CF R9CH R9CI R9DA R9DB R9DC R9DD</p> <p>4 Cyl. 1999 ccm Cyl. 87,5 Ø</p> <p>Focus 07/2012 →</p> <p>Galaxy 01/2015 →</p> <p>Mondeo 01/2013 →</p> <p>S-Max 01/2015 →</p>	<p>CS→ 805.070</p>			<p>ZKHS 689.970 BB5E-6K260-AB 5 152 332</p>  <p>709.690 BR3E-6P251-BA 5 053 748 ↑ 2x</p> 







			<p>a) </p> <p>b) </p>	<p>K: </p> <p>N: </p>	
<p>026.680 3S4G 6A517AA 1 151 825 FPM E 8x</p>  <p>026.650 1S7G 6A517BG 1 206 655 FPM A 8x</p> 	<p>024.390 5S43 9448AD 1 112 701</p> 	<p>874.301 1S7G 9441AE 1 119 284 4x</p> 	<p>a) 036.164 Dirko HT / EU</p> <p>a) 510.031 Dirko HT / USA/CDN/MEX</p> <p>a) 527.291 Dirko HT / RU</p> <p>a) 648.661 Dirko HT / BR</p> <p>b) 012.001 97JM 6730BA 1 013 938 M 14x1,5x20</p> <p>b) 176.090 97JM 6734BA 1 005 593 13x22,4x3</p>	<p>K:← 023.631 1S7G 6700AC 1 119 162 AS RD FPM 37x50x6</p> <p>K:← 649.250 CM5E-6700-AB AS OF RD FPM 37x50x6</p> <p>K:→ 023.940 1S7G 6A321AA 1 211 759 IWD LD PTFE 88x180x15</p>	
<p>026.680 3S4G 6A517AA 1 151 825 FPM E 8x</p>  <p>026.650 1S7G 6A517BG 1 206 655 FPM A 8x</p> 	<p>024.390 5S43 9448AD 1 112 701</p> 	<p>874.301 1S7G 9441AE 1 119 284 4x</p> 	<p>a) 036.164 Dirko HT / EU</p> <p>a) 510.031 Dirko HT / USA/CDN/MEX</p> <p>a) 527.291 Dirko HT / RU</p> <p>a) 648.661 Dirko HT / BR</p> <p>b) 012.001 97JM 6730BA 1 013 938 M 14x1,5x20</p> <p>b) 176.090 97JM 6734BA 1 005 593 13x22,4x3</p>	<p>K:← 023.631 1S7G 6700AC 1 119 162 AS RD FPM 37x50x6</p> <p>K:← 649.250 CM5E-6700-AB AS OF RD FPM 37x50x6</p> <p>K:→ 023.940 1S7G 6A321AA 1 211 759 IWD LD PTFE 88x180x15</p>	
<p>026.680 3S4G 6A517AA 1 151 825 FPM E 8x</p>  <p>026.650 1S7G 6A517BG 1 206 655 FPM A 8x</p> 	<p>756.920 CJ5E9448CA 5315730</p>	<p>756.820 CJ5E9439AA 5147345 4x</p>	<p>a) 036.164 Dirko HT / EU</p> <p>a) 510.031 Dirko HT / USA/CDN/MEX</p> <p>a) 527.291 Dirko HT / RU</p> <p>a) 648.661 Dirko HT / BR</p> <p>b) 823.400 4 948 795 M 12x1,75x17</p> <p>b) 056.130 FPM RD 10,8x20,8x2,6</p>	<p>K:← 023.631 1S7G 6700AC 1 119 162 AS RD FPM 37x50x6</p> <p>K:← 649.250 CM5E-6700-AB AS OF RD FPM 37x50x6</p> <p>K:→ 023.940 1S7G 6A321AA 1 211 759 IWD LD PTFE 88x180x15</p>	<p>TLS 806.390</p>



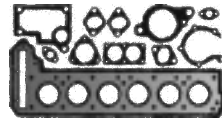
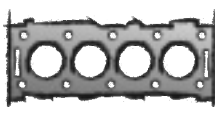

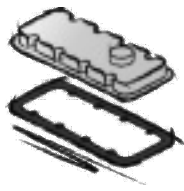







<p>FORD</p> 				
<p>R9MA R9MB</p> <p>4 Cyl. 1999 ccm Cyl. 87,5 Ø</p> <p>Kuga 01/2014 →</p>	<p>CS→ 805.070 →09/2016</p> <p>CS→ 806.070 09/2016→</p>			<p>ZKHS 689.970 BB5E-6K260-AB 5 152 332</p>  <p>709.690 BR3E-6P251-BA 5 053 748 ↑ 2x</p> 
<p>TNBA TNBB TPBA</p> <p>4 Cyl. 1999 ccm Cyl. 87,5 Ø</p> <p>Mondeo 03/2010 → 01/2015</p>	<p>ES⊕ 513.330 CS* 497.120</p>	<p>452.850 BB5E 6051BB 5 194 031 0,93 mm $\frac{3}{32}$ 89 Ø</p> 		<p>ZKHS 534.180 AG9G6K260CB 1684633 →05/2011</p> <p>ZKHS 689.970 BB5E-6K260-AB 5 152 332 05/2011→</p>  <p>598.080 AG9G-6K260-BC 5 357 119 ↑ 2x</p> 

			<p>a) </p> <p>b) </p>	<p>K: </p> <p>N: </p>	
<p>026.680 3S4G 6A517AA 1 151 825 FPM E 8x</p>  <p>026.650 1S7G 6A517BG 1 206 655 FPM A 8x</p> 	<p>756.920 CJ5E9448CA 5315730</p>	<p>756.820 CJ5E9439AA 5147345 4x</p>	<p>a) 036.164 Dirko HT / EU</p> <p>a) 510.031 Dirko HT / USA/CDN/MEX</p> <p>a) 527.291 Dirko HT / RU</p> <p>a) 648.661 Dirko HT / BR</p>	<p>K:→ 023.940 1S7G 6A321AA 1 211 759 IWD LD PTFE 88x180x15</p>	<p>TLS 806.390</p>
<p>026.680 3S4G 6A517AA 1 151 825 FPM E 8x</p>  <p>026.650 1S7G 6A517BG 1 206 655 FPM A 8x</p> 	<p>643.040 AG9N-9448AB 1 682 132</p> 	<p>690.000 AG9G 9441BA 1 682 146 4x</p>	<p>a) 036.164 Dirko HT / EU</p> <p>a) 510.031 Dirko HT / USA/CDN/MEX</p> <p>a) 527.291 Dirko HT / RU</p> <p>a) 648.661 Dirko HT / BR</p> <p>b) 823.400 4 948 795 M 12x1,75x17</p> <p>b) 056.130 FPM RD 10,8x20,8x2,6</p>	<p>K:← 023.631 1S7G 6700AC 1 119 162 AS RD FPM 37x50x6</p> <p>K:← 649.250 CM5E-6700-AB AS OF RD FPM 37x50x6</p> <p>K:→ 023.940 1S7G 6A321AA 1 211 759 IWD LD PTFE 88x180x15</p>	<p>TLS 513.940</p>

FORD 					
TNCA TNCC TNCF 4 Cyl. 1999 ccm Cyl. 87,5 Ø Mondeo 09/2014 →	TNCB TNCD	CS* 781.240			ZKHS 689.970 BB5E-6K260-AB 5 152 332  709.690 BR3E-6P251-BA 5 053 748 ↑ 2x 
TNWA TPWA 4 Cyl. 1999 ccm Cyl. 87,5 Ø Galaxy 03/2010 → 06/2015 S-Max 03/2010 → 12/2014	TNWB	ES⊕ 513.330 CS* 497.120	452.850 BB5E 6051BB 5 194 031 0,93 mm $\frac{3}{32}$ 89 Ø 		ZKHS 534.180 AG9G6K260CB 1684633 →10/2011 ZKHS 689.970 BB5E-6K260-AB 5 152 332 10/2011→  598.080 AG9G-6K260-BC 5 357 119 ↑ 2x 

			<p>a) </p> <p>b) </p>	<p>K: </p> <p>N: </p>	
<p>026.680 3S4G 6A517AA 1 151 825 FPM E 8x</p>  <p>026.650 1S7G 6A517BG 1 206 655 FPM A 8x</p> 	<p>756.920 CJ5E9448CA 5315730</p>	<p>756.820 CJ5E9439AA 5147345 4x</p>	<p>a) 036.164 Dirko HT / EU</p> <p>a) 510.031 Dirko HT / USA/CDN/MEX</p> <p>a) 527.291 Dirko HT / RU</p> <p>a) 648.661 Dirko HT / BR</p> <p>b) 823.400 4 948 795 M 12x1,75x17</p> <p>b) 056.130 FPM RD 10,8x20,8x2,6</p>	<p>K:← 023.631 1S7G 6700AC 1 119 162 AS RD FPM 37x50x6</p> <p>K:← 649.250 CM5E-6700-AB AS OF RD FPM 37x50x6</p> <p>K:→ 023.940 1S7G 6A321AA 1 211 759 IWD LD PTFE 88x180x15</p>	<p>TLS 806.390</p>
<p>026.680 3S4G 6A517AA 1 151 825 FPM E 8x</p>  <p>026.650 1S7G 6A517BG 1 206 655 FPM A 8x</p> 	<p>643.040 AG9N-9448AB 1 682 132</p> 	<p>690.000 AG9G 9441BA 1 682 146 4x</p>	<p>a) 036.164 Dirko HT / EU</p> <p>a) 510.031 Dirko HT / USA/CDN/MEX</p> <p>a) 527.291 Dirko HT / RU</p> <p>a) 648.661 Dirko HT / BR</p> <p>b) 823.400 4 948 795 M 12x1,75x17</p> <p>b) 056.130 FPM RD 10,8x20,8x2,6</p>	<p>K:← 023.631 1S7G 6700AC 1 119 162 AS RD FPM 37x50x6</p> <p>K:← 649.250 CM5E-6700-AB AS OF RD FPM 37x50x6</p> <p>K:→ 023.940 1S7G 6A321AA 1 211 759 IWD LD PTFE 88x180x15</p>	<p>TLS 513.940</p>

<p>FORD</p> 				
<p>UACA UACC UADA</p> <p>4 Cyl. 1999 ccm Cyl. 87,5 Ø</p> <p>C-Max 01/2015 → 06/2019</p> <p>Mondeo 09/2014 →</p>	<p>CS* 781.240</p>			<p>ZKHS 001.563 1S7G 6K260AA 1 220 025</p>  <p>PLASTIC</p>  <p>709.690 BR3E-6P251-BA 5 053 748 ↑</p> 
<p>MGDA XQDA</p> <p>4 Cyl. 1999 ccm Cyl. 87,5 Ø</p> <p>Ecosport 01/2018 →</p> <p>Focus 07/2010 →</p>	<p>CS* 781.240</p>			<p>ZKHS 771.310 CM5E-6D271-AA 5 143 612</p> <p>709.690 BR3E-6P251-BA 5 053 748 ↑</p> 

			<p>a) </p> <p>b) </p>	<p>K: </p> <p>N: </p>	
<p>026.680 3S4G 6A517AA 1 151 825 FPM E 8x</p>  <p>026.650 1S7G 6A517BG 1 206 655 FPM A 8x</p> 	<p>709.040 CV61-9448-AB 5 305 978</p>	<p>874.301 1S7G 9441AE 1 119 284 4x</p> 	<p>a) 036.164 Dirko HT / EU</p> <p>a) 510.031 Dirko HT / USA/CDN/MEX</p> <p>a) 527.291 Dirko HT / RU</p> <p>a) 648.661 Dirko HT / BR</p> <p>b) 823.400 4 948 795 M 12x1,75x17</p> <p>b) 056.130 FPM RD 10,8x20,8x2,6</p>	<p>K:← 023.631 1S7G 6700AC 1 119 162 AS RD FPM 37x50x6</p> <p>K:← 649.250 CM5E-6700-AB AS OF RD FPM 37x50x6</p> <p>K:→ 023.940 1S7G 6A321AA 1 211 759 IWD LD PTFE 88x180x15</p>	
<p>026.680 3S4G 6A517AA 1 151 825 FPM E 8x</p>  <p>026.650 1S7G 6A517BG 1 206 655 FPM A 8x</p> 	<p>771.330 BV61-9448-AD 5 192 589</p>	<p>771.320 CM5E-9439-AA 5 112 231 4x</p>	<p>a) 036.164 Dirko HT / EU</p> <p>a) 510.031 Dirko HT / USA/CDN/MEX</p> <p>a) 527.291 Dirko HT / RU</p> <p>a) 648.661 Dirko HT / BR</p>	<p>K:← 023.631 1S7G 6700AC 1 119 162 AS RD FPM 37x50x6</p> <p>K:→ 023.940 1S7G 6A321AA 1 211 759 IWD LD PTFE 88x180x15</p>	

FORD

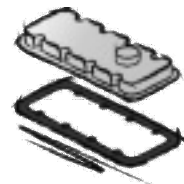
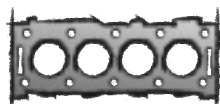
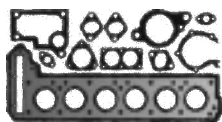

KNBA KNWA **KNBB KNWB**

4 Cyl. **2179 ccm**
Cyl. 85,0 Ø

Galaxy TDCi
11/2010 → 06/2015

Mondeo TDCi
07/2010 → 01/2015

S-Max TDCi
07/2010 → 12/2014

CS* **729.880**

732.160

6G9Q 6051AB
1 615 048

0,550 mm
→
0,600 mm

1,25 mm ± 86 Ø
1 ⊗

732.170

6G9Q 6051BB
1 615 051

0,610 mm
→
0,650 mm

1,30 mm ± 86 Ø
2 ⊗

732.180

6G9Q 6051CB
1 615 056

0,660 mm
→
0,700 mm

1,35 mm ± 86 Ø
3 ⊗

732.190

6G9Q 6051EB
1 615 086

0,710 mm
→
0,750 mm

1,40 mm ± 86 Ø
4 ⊗

ZKS 267.551

1 792 821 (10x)
1 445 927 (10x)
M 12x1,5x121

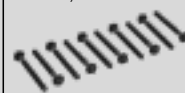

ZKHS 469.070



790.690

1 435 561



Q4BA Q4WA

4 Cyl. **2179 ccm**
Cyl. 85,0 Ø

Galaxy TDCi
03/2008 → 12/2012

Mondeo TDCi
03/2008 → 10/2010

S-Max TDCi
03/2008 → 12/2012

ES⊕ **449.600**



CS* **729.880**

732.160

6G9Q 6051AB
1 615 048

0,550 mm
→
0,600 mm

1,25 mm ± 86 Ø
1 ⊗

732.170

6G9Q 6051BB
1 615 051

0,610 mm
→
0,650 mm

1,30 mm ± 86 Ø
2 ⊗

732.180

6G9Q 6051CB
1 615 056

0,660 mm
→
0,700 mm

1,35 mm ± 86 Ø
3 ⊗

732.190

6G9Q 6051EB
1 615 086

0,710 mm
→
0,750 mm

1,40 mm ± 86 Ø
4 ⊗

ZKS 267.551

1 792 821 (10x)
1 445 927 (10x)
M 12x1,5x121

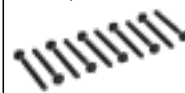











ZKHS 469.070



790.690

1 435 561



			<p>a) </p> <p>b) </p>	<p>K: </p> <p>N: </p>	
<p>VAS 453.750 FPM</p>		<p>AAS 469.080 1 466 211</p> 	<p>a) 036.164 Dirko HT / EU</p> <p>a) 510.031 Dirko HT / USA/CDN/MEX</p> <p>a) 527.291 Dirko HT / RU</p> <p>a) 648.661 Dirko HT / BR</p> <p>b) 877.930 incl. 108.502 M 10x1,25x13</p> <p>b) 108.502 2S6Q 6734AA 1 145 962 CU A 10x21x2,1</p>	<p>K:← 393.990 3M5Q 6700BC 1 350 608 ASW RD PTFE/ACM 42x62x7</p> <p>K:→ 394.012 ASW LD PTFE/ACM 90x110x8</p> <p>N:← 153.740 3M5Q 6L270BA 1 231 972 ASW RD FPM 27x47x7</p>	
<p>VAS 453.750 FPM</p>	<p>901.840 1 427 930</p> 	<p>AAS 469.080 1 466 211</p> 	<p>a) 030.793 Dirko HT</p> <p>b) 877.930 incl. 108.502 M 10x1,25x13</p> <p>b) 108.502 2S6Q 6734AA 1 145 962 CU A 10x21x2,1</p>	<p>K:← 393.990 3M5Q 6700BC 1 350 608 ASW RD PTFE/ACM 42x62x7</p> <p>K:→ 394.012 ASW LD PTFE/ACM 90x110x8</p> <p>N:← 153.740 3M5Q 6L270BA 1 231 972 ASW RD FPM 27x47x7</p>	

FORD

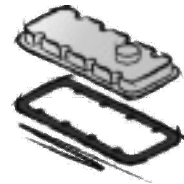
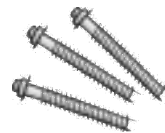
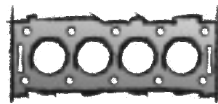
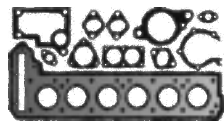

CVF5 CVFF
 CY14 CYF4/5
 CYFA CYFB
 CYFC CYFD
 CYFF CYFG
 DRF4/5 DRFA
 DRFB DRFC
 DRFD DRFE
 DRFF DRFG

4 Cyl. 2198 ccm
 Cyl. 86,0 Ø

Tourneo TDCi
 04/2012 → 12/2015
Transit TDCi
 10/2011 → 12/2018
Transit Tourneo TDCi
 10/2011 → 08/2014

ES⊕ 573.350

 CS* 437.370

156.201
 6C1Q 6051AB
 1 372 282
 0,430 mm
 →
 0,520 mm
 1,10 mm ± 87,1 Ø
 1 ∇

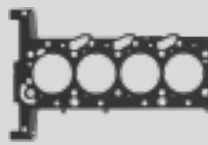

156.211
 6C1Q 6051BB
 1 372 297
 0,521 mm
 →
 0,570 mm
 1,15 mm ± 87,1 Ø
 2 ∇

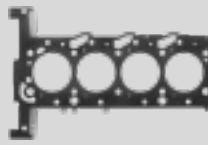

156.221
 6C1Q 6051CB
 1 372 299
 0,571 mm
 →
 0,620 mm
 1,20 mm ± 87,1 Ø
 3 ∇



ZKS 733.100
 1 102 676 (8x)
 +1 372 302 (10x)
 M 10x1,5x140
M
 8x1,25x121



469.690
 BK3Q-9T529-AB
 1 760 813
 ↑
 2x

568.860
 BK2Q 6K260AB
 1 848 542





722.080
 BK2Q-6K780BA
 1 760 803
 4x

QJBA QJBB
 QJBC QJBD

4 Cyl. 2198 ccm
 Cyl. 86,0 Ø

Mondeo TDCi
 09/2004 → 03/2007

ES⊕ 376.672
 →08/2005

 CS* 030.551

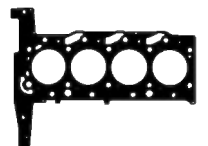
265.371
 5S7Q 6051AA
 1 349 880
 0,430 mm
 →
 0,520 mm
 1,10 mm ± 87,1 Ø
 1 ∇

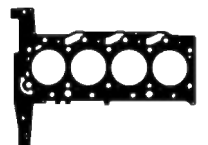

265.381
 5S7Q 6051BA
 1 349 890
 0,521 mm
 →
 0,570 mm
 1,15 mm ± 87,1 Ø
 2 ∇



265.391
 5S7Q 6051CA
 1 349 899
 0,571 mm
 →
 0,620 mm
 1,20 mm ± 87,1 Ø
 3 ∇

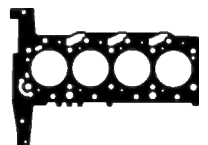

ZKS 175.580
 1 102 676 (8x)
 +1 102 674 (10x)
 M 10x1,5x160 M
 8x1,25x121



ZKHS 389.080



















027.720
 6C1Q 6K260AA
 1 372 490



569.770
 YC1Q 6K780BB
 1 121 656
 4x

389.140
 12x

			<p>a) </p> <p>b) </p>	<p>K: </p> <p>N: </p>	
<p>027.740 XS7Q 6571AD 1 357 589 FPM 16x</p> 		<p>027.150 XS7Q 8565AA 1 138 392 8x</p> 	<p>a) OWS 027.371 3S7Q 6710BA 1 498 320</p>  <p>a) 036.164 Dirko HT / EU ↓ a) 510.031 Dirko HT / USA/CDN/MEX ↓ a) 527.291 Dirko HT / RU ↓ a) 648.661 Dirko HT / BR ↓ b) 012.001 97JM 6730BA 1 013 938 M 14x1,5x20 b) 176.090 97JM 6734BA 1 005 593 13x22,4x3</p>	<p>K:← 026.782 1 801 837 ASW RD PTFE 50x90x14</p> <p>K:→ 026.812 3S7Q 6385AB 1 684 287 IWD LD PTFE/ACM 106x215</p>	<p>TLS 541.620</p>
<p>027.740 XS7Q 6571AD 1 357 589 FPM 16x</p> 	<p>026.980 2S7Q 9448 CB 1 360 555 →08/2005</p> 	<p>027.150 XS7Q 8565AA 1 138 392 8x</p> 	<p>a) OWS 027.371 3S7Q 6710BA 1 498 320</p>  <p>a) 036.164 Dirko HT / EU ↓ a) 510.031 Dirko HT / USA/CDN/MEX ↓ a) 527.291 Dirko HT / RU ↓ a) 648.661 Dirko HT / BR ↓ b) 012.001 97JM 6730BA 1 013 938 M 14x1,5x20 b) 176.090 97JM 6734BA 1 005 593 13x22,4x3</p>	<p>K:← 026.782 1 801 837 ASW RD PTFE 50x90x14</p> <p>K:→ 026.812 3S7Q 6385AB 1 684 287 IWD LD PTFE/ACM 106x215</p> <p>N:← 903.600 1 139 357 ASW LD PTFE/ACM 36x50x7</p>	<p>TLS 733.570 incl. 026.980 →08/2005</p> 

FORD

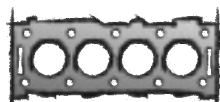
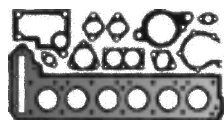

P8FA P8FB
PGFA PGFB
QVFA QWFA
SRFA SRFB
SRFC SRFD
SRFE

4 Cyl. **2198 ccm**
 Cyl. 86,0 Ø

Transit TDCi
 04/2006 → 08/2014
Transit Tourneo TDCi
 07/2006 → 08/2014

ES⊕ **052.091**

 CS* **437.370**

156.201
 6C1Q 6051AB
 1 372 282
 0,430 mm
 →
 0,520 mm
 1,10 mm $\frac{3}{4}$ 87,1 Ø
 1 ▽



156.211
 6C1Q 6051BB
 1 372 297
 0,521 mm
 →
 0,570 mm
 1,15 mm $\frac{3}{4}$ 87,1 Ø
 2 ▽



156.221
 6C1Q 6051CB
 1 372 299
 0,571 mm
 →
 0,620 mm
 1,20 mm $\frac{3}{4}$ 87,1 Ø
 3 ▽



ZKS 733.100
 1 102 676 (8x)
 +1 372 302 (10x)
 M 10x1,5x140
M
 8x1,25x121



ZKHS 052.100



173.700
 6C1Q-9T529-AB
 1 372 495
 ↑
 2x



027.720
 6C1Q 6K260AA
 1 372 490

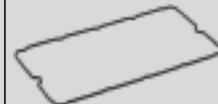

177.700
 6C1Q 6K780AB
 1 372 494
 4x



389.140
 12x

UHFA UHFB
UHFC

4 Cyl. **2198 ccm**
 Cyl. 86,0 Ø

Transit TDCi
 10/2007 → 08/2014
Transit Tourneo TDCi
 10/2007 → 08/2014

ES⊕ **573.350**

 CS* **437.370**

156.201
 6C1Q 6051AB
 1 372 282
 0,430 mm
 →
 0,520 mm
 1,10 mm $\frac{3}{4}$ 87,1 Ø
 1 ▽



156.211
 6C1Q 6051BB
 1 372 297
 0,521 mm
 →
 0,570 mm
 1,15 mm $\frac{3}{4}$ 87,1 Ø
 2 ▽



156.221
 6C1Q 6051CB
 1 372 299
 0,571 mm
 →
 0,620 mm
 1,20 mm $\frac{3}{4}$ 87,1 Ø
 3 ▽



ZKS 733.100
 1 102 676 (8x)
 +1 372 302 (10x)
 M 10x1,5x140
M
 8x1,25x121



















469.690
 BK3Q-9T529-AB
 1 760 813
 ↑
 2x

568.860
 BK2Q 6K260AB
 1 848 542



722.080
 BK2Q-6K780BA
 1 760 803
 4x

			<p>a) </p> <p>b) </p>	<p>K: </p> <p>N: </p>	
<p>027.740 XS7Q 6571AD 1 357 589 FPM 16x</p> 	<p>006.970 6C1Q 9448AB 1 456 895</p> 	<p>027.150 XS7Q 8565AA 1 138 392 8x</p> 	<p>a) OWS 027.371 3S7Q 6710BA 1 498 320</p>  <p>a) 036.164 Dirko HT / EU ↓ a) 510.031 Dirko HT / USA/CDN/MEX ↓ a) 527.291 Dirko HT / RU ↓ a) 648.661 Dirko HT / BR ↓ b) 012.001 97JM 6730BA 1 013 938 M 14x1,5x20 b) 176.090 97JM 6734BA 1 005 593 13x22,4x3</p>	<p>K:← 026.782 1 801 837 ASW RD PTFE 50x90x14</p> <p>K:→ 026.812 3S7Q 6385AB 1 684 287 IWD LD PTFE/ACM 106x215</p>	<p>TLS 047.190</p> 
<p>027.740 XS7Q 6571AD 1 357 589 FPM 16x</p> 		<p>027.150 XS7Q 8565AA 1 138 392 8x</p> 	<p>a) OWS 027.371 3S7Q 6710BA 1 498 320</p>  <p>a) 036.164 Dirko HT / EU ↓ a) 510.031 Dirko HT / USA/CDN/MEX ↓ a) 527.291 Dirko HT / RU ↓ a) 648.661 Dirko HT / BR ↓ b) 012.001 97JM 6730BA 1 013 938 M 14x1,5x20 b) 176.090 97JM 6734BA 1 005 593 13x22,4x3</p>	<p>K:← 026.782 1 801 837 ASW RD PTFE 50x90x14</p> <p>K:→ 026.812 3S7Q 6385AB 1 684 287 IWD LD PTFE/ACM 106x215</p>	<p>TLS 047.190</p> 

FORD

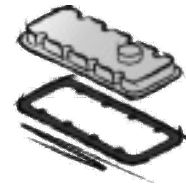
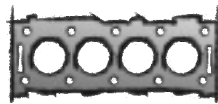
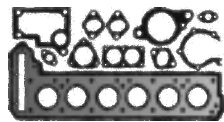

USF6

4 Cyl. **2198 ccm**
Cyl. 86,0 Ø

Transit TDCi

08/2013 → 12/2018

ES⊕ **573.350**



CS* **437.370**

156.201

6C1Q 6051AB
1 372 282

0,430 mm
→
0,520 mm

1,10 mm $\frac{\pm}{\pm}$ 87,1 Ø
1 ▽

156.211

6C1Q 6051BB
1 372 297

0,521 mm
→
0,570 mm

1,15 mm $\frac{\pm}{\pm}$ 87,1 Ø
2 ▽

156.221

6C1Q 6051CB
1 372 299

0,571 mm
→
0,620 mm

1,20 mm $\frac{\pm}{\pm}$ 87,1 Ø
3 ▽

ZKS 733.100

1 102 676 (8x)
+1 372 302 (10x)
M 10x1,5x140
M
8x1,25x121



568.860

BK2Q 6K260AB
1 848 542



722.080

BK2Q-6K780BA
1 760 803
4x

CV24 **CVR5**
CVRA **CVRB**
CVRC **CY24**
CYR5 **CYRA**
CYRB **CYRC**
DRR5 **DRRA**
DRRB **DRRC**
ENPF **ENQJ**
ENQW **GBVAJPF**
GBVAJQJ **GBVAJQW**
T22DD0P **UHR5**
USR6 **USRA**
USRB **UYR6**

4 Cyl. **2198 ccm**
Cyl. 86,0 Ø

Ranger TDCi

04/2011 →

Transit TDCi

09/2011 → 12/2018

ES⊕ **573.370**

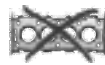

CS* **572.890**

818.900

BK3Q-6051-A1C
1 776 498

1,10 mm $\frac{\pm}{\pm}$ 87,4 Ø
1 ⊗

818.910

BK3Q-6051-B1C
1 776 501

1,15 mm $\frac{\pm}{\pm}$ 87,4 Ø
2 ⊗

818.920

BK3Q-6051-C1C
1 776 502

1,20 mm $\frac{\pm}{\pm}$ 87,4 Ø
3 ⊗

ZKS 733.100

1 102 676 (8x)
+1 372 302 (10x)
M 10x1,5x140
M
8x1,25x121



469.690

BK3Q-9T529-AB
1 760 813

↑
2x















568.860









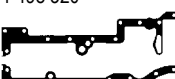

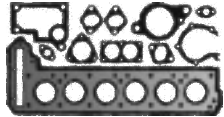
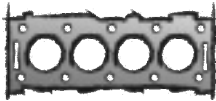

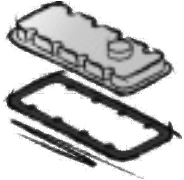
BK2Q 6K260AB
1 848 542

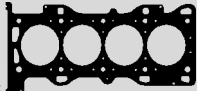

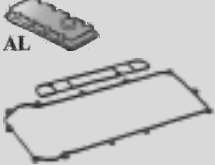

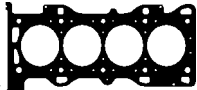
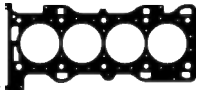

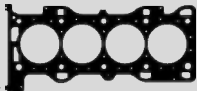













722.080

BK2Q-6K780BA
1 760 803
4x

			<p>a) </p> <p>b) </p>	<p>K: </p> <p>N: </p>	
<p>027.740 XS7Q 6571AD 1 357 589 FPM 16x</p> 		<p>027.150 XS7Q 8565AA 1 138 392 8x</p> 	<p>a) OWS 027.371 3S7Q 6710BA 1 498 320</p>  <p>a) 036.164 Dirko HT / EU ↓ a) 510.031 Dirko HT / USA/CDN/MEX ↓ a) 527.291 Dirko HT / RU ↓ a) 648.661 Dirko HT / BR ↓ b) 012.001 97JM 6730BA 1 013 938 M 14x1,5x20 b) 176.090 97JM 6734BA 1 005 593 13x22,4x3</p>	<p>K:← 026.782 1 801 837 ASW RD PTFE 50x90x14</p> <p>K:→ 026.812 3S7Q 6385AB 1 684 287 IWD LD PTFE/ACM 106x215</p>	<p>TLS 541.620</p>
<p>027.740 XS7Q 6571AD 1 357 589 FPM 16x</p> 	<p>392.440 2C1Q 9448AB 1 360 589</p> 	<p>027.150 XS7Q 8565AA 1 138 392 8x</p> 	<p>a) OWS 027.371 3S7Q 6710BA 1 498 320</p>  <p>a) 036.164 Dirko HT / EU ↓ a) 510.031 Dirko HT / USA/CDN/MEX ↓ a) 527.291 Dirko HT / RU ↓ a) 648.661 Dirko HT / BR ↓ b) 012.001 97JM 6730BA 1 013 938 M 14x1,5x20 b) 176.090 97JM 6734BA 1 005 593 13x22,4x3</p>	<p>K:← 026.782 1 801 837 ASW RD PTFE 50x90x14</p> <p>K:→ 026.812 3S7Q 6385AB 1 684 287 IWD LD PTFE/ACM 106x215</p>	

<p>FORD</p> 				
<p>GZ</p> <p>4 Cyl. 2261 ccm Cyl. 87,5 Ø</p> <p>Maverick 03/2004 →</p>	<p>ES⊕ 027.470</p> 	<p>255.070 1S7G 6051AJ 1 229 872 0,50 mm \pm 89 Ø</p> 	<p>ZKS 028.230 1 229 267 (10x) M 10x1,25x145,5</p> 	<p>ZKHS 026.551 1S7G 6584AE 1 119 878</p> <p>AL</p>  <p>ZKHS 001.563 1S7G 6K260AA 1 220 025</p> <p>PLASTIC</p> 
<p>GZFA GZFB</p> <p>4 Cyl. 2261 ccm Cyl. 87,5 Ø</p> <p>Transit 04/2006 → 08/2014</p>	<p>ES⊕ 572.830 1 319 868 01/2010→</p>	<p>255.070 1S7G 6051AJ 1 229 872 0,50 mm \pm 89 Ø →12/2009</p> <p>226.220 6M8Z-6051AC 1 355 862 0,40 mm \pm 89 Ø 01/2010→</p>  	<p>ZKS 028.230 1 229 267 (10x) M 10x1,25x145,5</p> 	<p>ZKHS 001.563 1S7G 6K260AA 1 220 025</p> <p>PLASTIC</p> 
<p>SEBA SEWA</p> <p>4 Cyl. 2261 ccm Cyl. 87,5 Ø</p> <p>Galaxy 09/2007 → 06/2015</p> <p>Mondeo 07/2007 → 01/2015</p> <p>S-Max 07/2007 → 12/2014</p>	<p>ES⊕ 007.210 CS* 027.291</p>	<p>226.220 6M8Z-6051AC 1 355 862 0,40 mm \pm 89 Ø</p> 	<p>ZKS 028.230 1 229 267 (10x) M 10x1,25x145,5</p> 	<p>ZKHS 001.563 1S7G 6K260AA 1 220 025</p> <p>PLASTIC</p> 

			<p>a) </p> <p>b) </p>	<p>K: </p> <p>N: </p>	
<p>026.680 3S4G 6A517AA 1 151 825 FPM E 8x</p>  <p>026.650 1S7G 6A517BG 1 206 655 FPM A 8x</p> 	<p>024.390 5S43 9448AD 1 112 701</p> 	<p>874.301 1S7G 9441AE 1 119 284 4x</p> 	<p>a) 036.164 Dirko HT / EU</p> <p>a) 510.031 Dirko HT / USA/CDN/MEX</p> <p>a) 527.291 Dirko HT / RU</p> <p>a) 648.661 Dirko HT / BR</p> <p>b) 176.090 97JM 6734BA 1 005 593 13x22,4x3</p>	<p>K:← 023.631 1S7G 6700AC 1 119 162 AS RD FPM 37x50x6</p> <p>K:← 649.250 CM5E-6700-AB AS OF RD FPM 37x50x6</p> <p>K:→ 023.940 1S7G 6A321AA 1 211 759 IWD LD PTFE 88x180x15</p>	
<p>026.680 3S4G 6A517AA 1 151 825 FPM E 8x</p>  <p>026.650 1S7G 6A517BG 1 206 655 FPM A 8x</p> 		<p>874.301 1S7G 9441AE 1 119 284 4x</p> 	<p>a) 036.164 Dirko HT / EU</p> <p>a) 510.031 Dirko HT / USA/CDN/MEX</p> <p>a) 527.291 Dirko HT / RU</p> <p>a) 648.661 Dirko HT / BR</p> <p>b) 012.001 97JM 6730BA 1 013 938 M 14x1,5x20</p> <p>b) 176.090 97JM 6734BA 1 005 593 13x22,4x3</p>	<p>K:← 023.631 1S7G 6700AC 1 119 162 AS RD FPM 37x50x6</p> <p>K:← 649.250 CM5E-6700-AB AS OF RD FPM 37x50x6</p> <p>K:→ 023.940 1S7G 6A321AA 1 211 759 IWD LD PTFE 88x180x15</p>	
<p>026.680 3S4G 6A517AA 1 151 825 FPM E 8x</p>  <p>026.650 1S7G 6A517BG 1 206 655 FPM A 8x</p> 	<p>024.390 5S43 9448AD 1 112 701</p> 	<p>874.301 1S7G 9441AE 1 119 284 4x</p> 	<p>a) 036.164 Dirko HT / EU</p> <p>a) 510.031 Dirko HT / USA/CDN/MEX</p> <p>a) 527.291 Dirko HT / RU</p> <p>a) 648.661 Dirko HT / BR</p> <p>b) 012.001 97JM 6730BA 1 013 938 M 14x1,5x20</p> <p>b) 176.090 97JM 6734BA 1 005 593 13x22,4x3</p>	<p>K:← 023.631 1S7G 6700AC 1 119 162 AS RD FPM 37x50x6</p> <p>K:← 649.250 CM5E-6700-AB AS OF RD FPM 37x50x6</p> <p>K:→ 023.940 1S7G 6A321AA 1 211 759 IWD LD PTFE 88x180x15</p>	

FORD

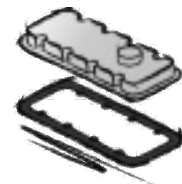
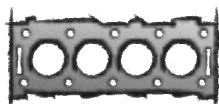
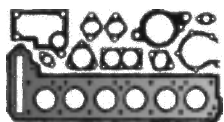

E5FA Y5A **E5FC**
 4 Cyl. **2295 ccm**
 Cyl. 89,6 Ø

Scorpio
 06/1996 → 08/1998
Transit
 08/2000 → 05/2006

ES⊕ **897.900**
 CS* **389.161**

388.190
 96XM 6051A3B
 1 019 030
 90,6 Ø

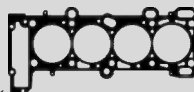

ZKS **802.900**
 1 073 369 (10x)
 M 11x1,5x173



ZKHS **569.860**



446.260
 95WM 6584AC
 7 024 740



E5SA Y5B **E5SB**
 4 Cyl. **2295 ccm**
 Cyl. 89,6 Ø

Galaxy
 09/1996 → 05/2006

ES⊕ **569.480**
 CS* **389.161**

374.990
 96XM 6051B3B
 1 022 220
 1,20 mm ± 90,5 Ø



ZKS **802.900**
 1 073 369 (10x)
 M 11x1,5x173

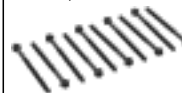

ZKHS **569.860**



446.260
 95WM 6584AC
 7 024 740

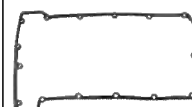

YTR YTT
 4 Cyl. **2304 ccm**
 Cyl. 94,0 Ø

Sierra
 08/1982 → 02/1993

694.502
 → 0,790 mm
 1,40 mm ± 96 Ø
 2 ▽



599.402 ●
 91EM 6051BA
 6 812 073
 → 0,790 mm
 → 0,890 mm
 1,50 mm ± 96 Ø
 3 ▽









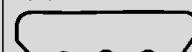







694.510
 91EM 6051CA
 6 812 074
 → 0,890 mm
 →
 1,60 mm ± 96 Ø
 4 ▽



109.193
 78EM 6584AA
 1 576 414



			<p>a) </p> <p>b) </p>	<p>K: </p> <p>N: </p>	
<p>766.615 88WM 6571A2A 6 166 533 FPM 16x</p>	<p>375.600 95XM 9448AA 7 087 454</p> 	<p>AAS 537.950</p>  <p>428.900 96XM 9461AA 1 019 046 4x</p> 	<p>b) 786.500 928M 6734AA 1 454 118 Nylon A 14,5x22x2</p>	<p>K:← 374.680 988M 6700A5B 1 102 415 ASW RD PTFE/ACM 35x50x7</p> <p>K:← 757.497 86HM 6700AA 1 669 254 ASW RD FPM 42x56x7</p> <p>K:→ 374.590 1M5G 6A321A5A 1 220 978 ASW LD PTFE/ACM 88x108x10</p> <p>K:→ 750.476 928M 6701B5A 6 126 179 ASW LD FPM 88x108x11</p>	
<p>766.615 88WM 6571A2A 6 166 533 FPM 16x</p>	<p>375.600 95XM 9448AA 7 087 454</p> 	<p>AAS 444.570 7 090 340 +1 023 120 +1 019 046 (4x)</p>  <p>428.900 96XM 9461AA 1 019 046 4x</p> 	<p>b) 786.500 928M 6734AA 1 454 118 Nylon A 14,5x22x2</p>	<p>K:← 374.680 988M 6700A5B 1 102 415 ASW RD PTFE/ACM 35x50x7</p> <p>K:← 757.497 86HM 6700AA 1 669 254 ASW RD FPM 42x56x7</p> <p>K:→ 374.590 1M5G 6A321A5A 1 220 978 ASW LD PTFE/ACM 88x108x10</p> <p>K:→ 750.476 928M 6701B5A 6 126 179 ASW LD FPM 88x108x11</p>	
			<p>a) 000.958 78EM 6710BA 1 608 019</p>  <p>b) 813.087 CU C 18x24x2</p>	<p>K:← 040.320 78EM 6700AA 1 576 424 A NBR 42x60x10</p> <p>K:← 040.606 A NBR 45x60x7</p> <p>K:→ 012.507 2x 1 576 425 GRP 65</p>	

FORD

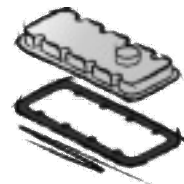
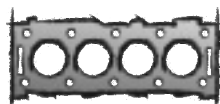
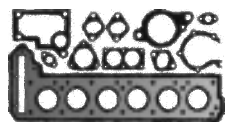

D2FA D2FB
D2FE D4FA
DOFA F4FA
FXFA H9FA
SWFA

4 Cyl. **2402 ccm**
 Cyl. 89,9 Ø

Transit DI
 01/2000 → 05/2006
Transit TD
 08/2000 → 08/2003
Transit TDCi
 03/2004 → 12/2011
Transit TDE
 07/2001 → 05/2006

S⊕* **122.121**

 ES⊕ **030.652**

 CS* **030.662**

265.421
 5C1Q 6051AA
 1 349 874
 0,310 mm
 →
 0,400 mm
 1,10 mm $\frac{\pm}{\pm}$ 91 Ø
 1 ▽

265.441
 5C1Q 6051BA
 1 349 875
 0,401 mm
 →
 0,450 mm
 1,15 mm $\frac{\pm}{\pm}$ 91 Ø
 2 ▽

265.481
 5C1Q 6051CA
 1 349 876
 0,451 mm
 →
 0,500 mm
 1,20 mm $\frac{\pm}{\pm}$ 91 Ø
 3 ▽

ZKS 175.580
 1 102 676 (8x)
 +1 102 674 (10x)
 M 10x1,5x160 M
 8x1,25x121

ZKHS 389.080

027.720
 6C1Q 6K260AA
 1 372 490

569.770
 YC1Q 6K780BB
 1 121 656
 4x
389.140
 12x

H9FB H9FD
JXFA JXFC
PHFA PHFC

4 Cyl. **2402 ccm**
 Cyl. 89,9 Ø

Transit TDCi
 04/2006 → 08/2014

ES⊕ **511.030**

 CS* **511.040**

265.421
 5C1Q 6051AA
 1 349 874
 0,310 mm
 →
 0,400 mm
 1,10 mm $\frac{\pm}{\pm}$ 91 Ø
 1 ▽

265.441
 5C1Q 6051BA
 1 349 875
 0,401 mm
 →
 0,450 mm
 1,15 mm $\frac{\pm}{\pm}$ 91 Ø
 2 ▽

265.481
 5C1Q 6051CA
 1 349 876
 0,451 mm
 →
 0,500 mm
 1,20 mm $\frac{\pm}{\pm}$ 91 Ø
 3 ▽

ZKS 175.580
 1 102 676 (8x)
 +1 102 674 (10x)
 M 10x1,5x160 M
 8x1,25x121



















ZKHS 052.100

173.700
 6C1Q-9T529-AB
 1 372 495
 ↑
 2x

027.720
 6C1Q 6K260AA
 1 372 490

177.700
 6C1Q 6K780AB
 1 372 494
 4x

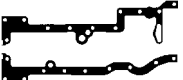
389.140
 12x

			<p>a) </p> <p>b) </p>	<p>K: </p> <p>N: </p>	
<p>027.740 XS7Q 6571AD 1 357 589 FPM 16x</p> 	<p>392.440 2C1Q 9448AB 1 360 589</p> 	<p>AAS 052.110 →05/2003</p>  <p>AAS 280.350 05/2003→</p>  <p>027.150 XS7Q 8565AA 1 138 392 8x</p> 	<p>a) OWS 027.371 3S7Q 6710BA 1 498 320</p>  <p>a) 036.164 Dirko HT / EU ↓ a) 510.031 Dirko HT / USA/CDN/MEX ↓ a) 527.291 Dirko HT / RU ↓ a) 648.661 Dirko HT / BR ↓ b) 012.001 97JM 6730BA 1 013 938 M 14x1,5x20 b) 176.090 97JM 6734BA 1 005 593 13x22,4x3</p>	<p>K:← 026.782 1 801 837 ASW RD PTFE 50x90x14</p> <p>K:→ 026.812 3S7Q 6385AB 1 684 287 IWD LD PTFE/ACM 106x215</p>	
<p>027.740 XS7Q 6571AD 1 357 589 FPM 16x</p> 	<p>392.440 2C1Q 9448AB 1 360 589</p> 	<p>027.150 XS7Q 8565AA 1 138 392 8x</p> 	<p>a) OWS 027.371 3S7Q 6710BA 1 498 320</p>  <p>a) 036.164 Dirko HT / EU ↓ a) 510.031 Dirko HT / USA/CDN/MEX ↓ a) 527.291 Dirko HT / RU ↓ a) 648.661 Dirko HT / BR ↓ b) 012.001 97JM 6730BA 1 013 938 M 14x1,5x20 b) 176.090 97JM 6734BA 1 005 593 13x22,4x3</p>	<p>K:← 026.782 1 801 837 ASW RD PTFE 50x90x14</p> <p>K:→ 026.812 3S7Q 6385AB 1 684 287 IWD LD PTFE/ACM 106x215</p>	<p>TLS 773.530</p> 

FORD

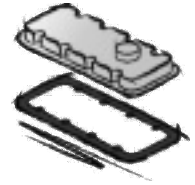
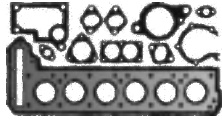

GBVAK

4 Cyl. 2488 ccm
Cyl. 89,0 Ø

Ranger

11/2011 →

ZKHS 001.563
1S7G 6K260AA
1 220 025



PLASTIC



S7GA
S7GB

4 Cyl. 2488 ccm

Transit Connect

09/2013 →

CS* 709.740

ZKS 028.230
1 229 267 (10x)
M 10x1,25x145,5



ZKHS 001.563
1S7G 6K260AA
1 220 025

















PLASTIC











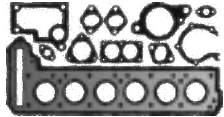
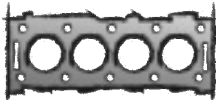

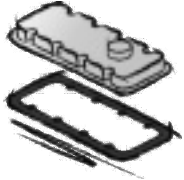









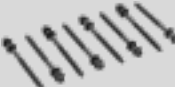









709.690
BR3E-6P251-BA
5 053 748











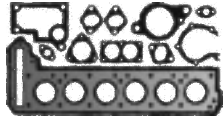
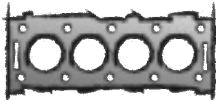

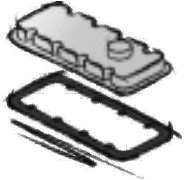



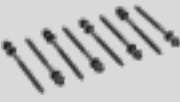





↑















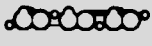
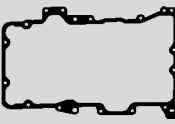

			<p>a) </p> <p>b) </p>	<p>K: </p> <p>N: </p>	
<p>026.680 3S4G 6A517AA 1 151 825 FPM E 8x</p>  <p>026.650 1S7G 6A517BG 1 206 655 FPM A 8x</p> 	<p>024.390 5S43 9448AD 1 112 701</p> 	<p>874.301 1S7G 9441AE 1 119 284 →01/2013 4x</p>  <p>708.610 8E5G-9441-AA 1 508 496 01/2013→ 4x</p>	<p>a) 036.164 Dirko HT / EU</p> <p>a) 510.031 Dirko HT / USA/CDN/MEX</p> <p>a) 527.291 Dirko HT / RU</p> <p>a) 648.661 Dirko HT / BR</p> <p>b) 012.001 97JM 6730BA 1 013 938 M 14x1,5x20 →02/2019</p> <p>b) 823.400 4 948 795 M 12x1,75x17 02/2019→</p> <p>b) 176.090 97JM 6734BA 1 005 593 13x22,4x3 →02/2019</p> <p>b) 056.130 FPM RD 10,8x20,8x2,6 02/2019→</p>	<p>K:← 023.631 1S7G 6700AC 1 119 162 AS RD FPM 37x50x6</p> <p>K:← 649.250 CM5E-6700-AB AS OF RD FPM 37x50x6</p>	
<p>026.680 3S4G 6A517AA 1 151 825 FPM E 8x</p>  <p>026.650 1S7G 6A517BG 1 206 655 FPM A 8x</p> 	<p>709.040 CV61-9448-AB 5 305 978</p>	<p>708.610 8E5G-9441-AA 1 508 496 4x</p>	<p>a) 036.164 Dirko HT / EU</p> <p>a) 510.031 Dirko HT / USA/CDN/MEX</p> <p>a) 527.291 Dirko HT / RU</p> <p>a) 648.661 Dirko HT / BR</p> <p>b) 823.400 4 948 795 M 12x1,75x17</p> <p>b) 056.130 FPM RD 10,8x20,8x2,6</p>	<p>K:← 649.250 CM5E-6700-AB AS OF RD FPM 37x50x6</p> <p>K:→ 023.940 1S7G 6A321AA 1 211 759 IWD LD PTFE 88x180x15</p>	

<p>FORD</p> 				
<p>YTMA</p> <p>4 Cyl. 2488 ccm Cyl. 89,0 Ø</p> <p>Kuga 01/2014 →</p> <p>Mondeo 09/2012 →</p>	<p>CS* 781.240</p>		<p>ZKS 028.230 1 229 267 (10x) M 10x1,25x145,5</p> 	<p>ZKHS 001.563 1S7G 6K260AA 1 220 025</p>  <p>709.690 BR3E-6P251-BA 5 053 748</p> <p>↑</p> 
<p>S7CB</p> <p>4 Cyl. 2489 ccm Cyl. 89,0 Ø</p> <p>Mondeo 05/2015 →</p>	<p>CS* 709.740</p>			<p>ZKHS 001.563 1S7G 6K260AA 1 220 025</p>  <p>709.690 BR3E-6P251-BA 5 053 748</p> <p>↑</p> 
<p>LCBB LCBC LCBE SEB SEC SGA</p> <p>6 Cyl. 2495 ccm Cyl. 81,6 Ø</p> <p>Cougar 08/1998 → 12/2001</p> <p>Mondeo 05/1999 → 09/2000</p>	<p>ES⊕ 027.490 F43X 6014AA 1 005 491 →09/2000</p> <p>ES⊕ 027.680 09/2000→</p> <p>CS* 027.600 F43X 6013AA 1 005 488 +3 780 203</p>	<p>025.120 XU3E 6083AA 3 922 601 L →09/2000</p> <p>025.070 4 129 205 1S7E 6083DE L 09/2000→</p> <p>025.130 XU3E 6051AB 4 028 565 R →09/2000</p> <p>025.090 4 552 600 1S7E 6051DE R 09/2000→</p>    	<p>ZKS 156.580 4 411 018 (8x) M 10x1,5x152,5 2x</p> 	<p>ZKHS 246.090 L</p>  <p>ZKHS 246.100 R</p> 

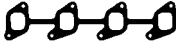
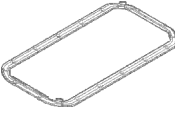
			<p>a) </p> <p>b) </p>	<p>K: </p> <p>N: </p>	
<p>026.680 3S4G 6A517AA 1 151 825 FPM E 8x</p>  <p>026.650 1S7G 6A517BG 1 206 655 FPM A 8x</p> 	<p>709.040 CV61-9448-AB 5 305 978</p>	<p>708.610 8E5G-9441-AA 1 508 496 4x</p>	<p>a) 036.164 Dirko HT / EU</p> <p>a) 510.031 Dirko HT / USA/CDN/MEX</p> <p>a) 527.291 Dirko HT / RU</p> <p>a) 648.661 Dirko HT / BR</p> <p>b) 823.400 4 948 795 M 12x1,75x17</p> <p>b) 056.130 FPM RD 10,8x20,8x2,6</p>	<p>K:← 023.631 1S7G 6700AC 1 119 162 AS RD FPM 37x50x6</p> <p>K:← 649.250 CM5E-6700-AB AS OF RD FPM 37x50x6</p> <p>K:→ 023.940 1S7G 6A321AA 1 211 759 IWD LD PTFE 88x180x15</p>	
<p>026.680 3S4G 6A517AA 1 151 825 FPM E 8x</p>  <p>026.650 1S7G 6A517BG 1 206 655 FPM A 8x</p> 	<p>709.040 CV61-9448-AB 5 305 978</p>	<p>708.610 8E5G-9441-AA 1 508 496 4x</p>	<p>a) 036.164 Dirko HT / EU</p> <p>a) 510.031 Dirko HT / USA/CDN/MEX</p> <p>a) 527.291 Dirko HT / RU</p> <p>a) 648.661 Dirko HT / BR</p> <p>b) 823.400 4 948 795 M 12x1,75x17</p> <p>b) 056.130 FPM RD 10,8x20,8x2,6</p>	<p>K:← 649.250 CM5E-6700-AB AS OF RD FPM 37x50x6</p> <p>K:→ 023.940 1S7G 6A321AA 1 211 759 IWD LD PTFE 88x180x15</p>	
<p>026.630 F53E 6A517AA 7 221 536 FPM 24x</p>	<p>024.760 XW4E 9448AC 4 503 102 2x</p> 	<p>025.300 F53E 9439BB 3 902 545 2x</p> 	<p>a) 025.460 4 174 016 2R8E 6710AA</p> 	<p>K:← 023.640 F3AE 6700AA 7 117 120 A/BS RD FPM 47,62x63,5x8,9</p> <p>K:→ 287.300 7 104 290 A/BS LD FPM 92,08x107,7x9,65</p> <p>N:→ 340.230 IWD FPM 26x45x23,4</p>	

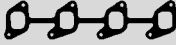
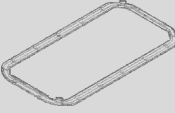
<p>FORD</p> 				
<p>LCBD</p> <p>6 Cyl. 2495 ccm Cyl. 81,6 Ø</p> <p>Metrostar 10/2000 → 02/2007</p> <p>Mondeo 06/2000 → 03/2007</p>	<p>ES⊕ 027.490 F43X 6014AA 1 005 491 →09/2000</p> <p>ES⊕ 027.680 09/2000→</p> <p>CS* 027.600 F43X 6013AA 1 005 488 +3 780 203</p>	<p>025.120 XU3E 6083AA 3 922 601 L →09/2000</p> <p>025.070 4 129 205 1S7E 6083DE L 09/2000→</p> <p>025.130 XU3E 6051AB 4 028 565 R →09/2000</p> <p>025.090 4 552 600 1S7E 6051DE R 09/2000→</p>    	<p>ZKS 156.580 4 411 018 (8x) M 10x1,5x152,5 2x</p> 	<p>ZKHS 246.090 L</p>  <p>ZKHS 246.100 R</p> 
<p>4BC 4CC 4FA 4FB 4FC 4FD</p> <p>4 Cyl. 2496 ccm Cyl. 93,7 Ø</p> <p>Transit DI 05/1991 → 03/2000</p> <p>Transit Tourneo DI 11/1994 → 12/2000</p>	<p>ES⊕ 476.930 924F 6014AA 6 689 715</p> 	<p>646.440 924F 6051AA 6 518 302 1,27 mm $\frac{1}{2}$ 95 Ø</p> 	<p>ZKS 802.930 6 093 964 (18x) M 12x1,75x92</p> 	<p>211.770 904F 6584CA 6 201 251</p> 
<p>4AB 4AE 4BA 4BB 4CA 4CB 4DA</p> <p>4 Cyl. 2496 ccm Cyl. 93,7 Ø</p> <p>Transit 10/1983 → 09/1992</p> <p>Transit DI 09/1988 → 08/1994</p>	<p>ES⊕ 476.920 894F 6014AA 6 173 218 →08/1989</p>  <p>ES⊕ 476.930 924F 6014AA 6 689 715 08/1989→</p> 	<p>646.440 924F 6051AA 6 518 302 1,27 mm $\frac{1}{2}$ 95 Ø</p> 	<p>ZKS 802.930 6 093 964 (18x) M 12x1,75x92</p> 	<p>458.200 844F 6584AA 6 094 666 →08/1989</p>  <p>211.770 904F 6584CA 6 201 251 08/1989→</p> 
<p>4EA 4EB 4EC 4ED 4GA 4GB 4GC 4GD 4GE 4GF</p> <p>4 Cyl. 2496 ccm Cyl. 93,7 Ø</p> <p>Transit DI 10/1992 → 03/2000</p> <p>Transit TD 05/1991 → 03/2000</p> <p>Transit Tourneo 11/1994 → 12/2000</p>	<p>ES⊕ 476.910 924F 6014BA 6 689 716</p> 	<p>646.440 924F 6051AA 6 518 302 1,27 mm $\frac{1}{2}$ 95 Ø</p> 	<p>ZKS 802.930 6 093 964 (18x) M 12x1,75x92</p> 	<p>211.770 904F 6584CA 6 201 251</p> 

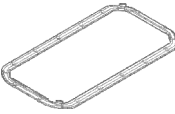
			<p>a) </p> <p>b) </p>	<p>K: </p> <p>N: </p>	
<p>026.630 F53E 6A517AA 7 221 536 FPM 24x</p>	<p>024.760 XW4E 9448AC 4 503 102 2x</p> 	<p>025.300 F53E 9439BB 3 902 545 2x</p> 	<p>a) 025.460 4 174 016 2R8E 6710AA →10/2003</p>  <p>a) 589.740 4 802 297 3W4E-6710DA 10/2003→</p> 	<p>K:← 023.640 F3AE 6700AA 7 117 120 A/BS RD FPM 47,62x63,5x8,9</p> <p>K:→ 287.300 7 104 290 A/BS LD FPM 92,08x107,7x9,65</p> <p>N:→ 340.230 IWD FPM 26x45x23,4</p>	
<p>467.880 924F 6571AA 6 597 036 FPM 8x</p>	<p>476.981 6 193 676 11/1991→</p> 	<p>476.991 894F 9461AB 6 525 815</p> 	<p>a) 112.000 894F 6710CA 6 193 087</p>  <p>b) 422.090 92FF 6734AA 6 835 866 NBR A 14x24x1,5 FE/NBR</p>	<p>K:→ 375.560 894F 6701AD 1 087 565 AW/BS LD PTFE/ACM 79x99x9,6</p> <p>N:← 516.406 894F 6L27AA 6 182 957 ASW RD PTFE/ACM 47,6x66,8x11,1</p>	
<p>467.880 924F 6571AA 6 597 036 FPM 8x</p>	<p>476.981 6 193 676 11/1991→</p> 	<p>476.991 894F 9461AB 6 525 815</p> 	<p>a) 112.000 894F 6710CA 6 193 087</p>  <p>b) 422.090 92FF 6734AA 6 835 866 NBR A 14x24x1,5 FE/NBR</p>	<p>K:→ 375.560 894F 6701AD 1 087 565 AW/BS LD PTFE/ACM 79x99x9,6 08/1989→</p> <p>N:← 516.406 894F 6L27AA 6 182 957 ASW RD PTFE/ACM 47,6x66,8x11,1</p>	
<p>467.880 924F 6571AA 6 597 036 FPM 8x</p>	<p>476.981 6 193 676</p> 	<p>060.161 6 751 295</p> 	<p>a) 112.000 894F 6710CA 6 193 087</p>  <p>b) 422.090 92FF 6734AA 6 835 866 NBR A 14x24x1,5 FE/NBR</p>	<p>K:→ 375.560 894F 6701AD 1 087 565 AW/BS LD PTFE/ACM 79x99x9,6</p> <p>N:← 516.406 894F 6L27AA 6 182 957 ASW RD PTFE/ACM 47,6x66,8x11,1</p>	

FORD

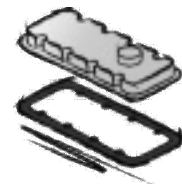
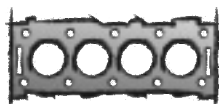
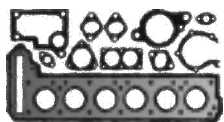

4HA 4HB
4HC 4HD
4 Cyl. **2496 ccm**
Cyl. 93,7 Ø

ES⊕ **476.930**
924F 6014AA
6 689 715

646.440
924F 6051AA
6 518 302
1,27 mm $\frac{1}{2}$ 95 Ø



ZKS **802.930**
6 093 964 (18x)
M 12x1,75x92



211.770
904F 6584CA
6 201 251



Transit DI
06/1994 → 03/2000
Transit TD
08/1994 → 06/2000
Transit Tourneo
08/1994 → 06/2000
Transit Tourneo DI
11/1994 → 12/2000

SFA SFB
4 Cyl. **2498 ccm**
Cyl. 94,0 Ø

Scorpio TD
06/1988 → 07/1993

694.502
 →
0,790 mm
1,40 mm $\frac{1}{2}$ 96 Ø
2 ▽



599.402 ●
91EM 6051BA
6 812 073
 0,790 mm
→
0,890 mm
1,50 mm $\frac{1}{2}$ 96 Ø
3 ▽



694.510
91EM 6051CA
6 812 074
 0,890 mm
→
1,60 mm $\frac{1}{2}$ 96 Ø
4 ▽



109.193
78EM 6584AA
1 576 414



STP
4 Cyl. **2498 ccm**
Cyl. 94,0 Ø

Granada
08/1982 → 08/1985

694.502
 →
0,790 mm
1,40 mm $\frac{1}{2}$ 96 Ø
2 ▽



599.402 ●
91EM 6051BA
6 812 073
 0,790 mm
→
0,890 mm
1,50 mm $\frac{1}{2}$ 96 Ø
3 ▽









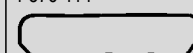



694.510
91EM 6051CA
6 812 074
 0,890 mm
→
1,60 mm $\frac{1}{2}$ 96 Ø
4 ▽

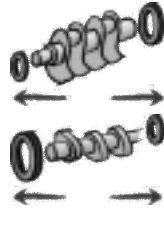

109.193
78EM 6584AA
1 576 414

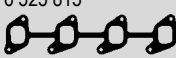
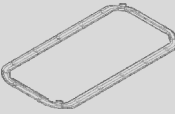

			<p>a) </p> <p>b) </p>	<p>K: </p> <p>N: </p>	
<p>467.880 924F 6571AA 6 597 036 FPM 8x</p>	<p>476.981 6 193 676</p> 	<p>476.991 894F 9461AB 6 525 815</p> 	<p>a) 112.000 894F 6710CA 6 193 087</p>  <p>b) 422.090 92FF 6734AA 6 835 866 NBR A 14x24x1,5 FE/NBR</p>	<p>K:→ 375.560 894F 6701AD 1 087 565 AW/BS LD PTFE/ACM 79x99x9,6</p> <p>N:← 516.406 894F 6L27AA 6 182 957 ASW RD PTFE/ACM 47,6x66,8x11,1</p>	
			<p>a) 000.958 78EM 6710BA 1 608 019</p>  <p>b) 813.087 CU C 18x24x2</p>	<p>K:← 040.606 A NBR 45x60x7</p> <p>K:→ 012.507 2x 1 576 425 GRP 65</p>	
			<p>a) 000.958 78EM 6710BA 1 608 019</p>  <p>b) 813.087 CU C 18x24x2</p>	<p>K:← 040.320 78EM 6700AA 1 576 424 A NBR 42x60x10</p> <p>K:→ 012.507 2x 1 576 425 GRP 65</p>	

FORD

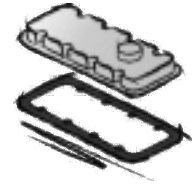

STR
4 Cyl. **2498 ccm**
Cyl. 94,0 Ø

Scorpio
12/1985 → 12/1994

S⊕* **925.600**

694.502
 → 0,790 mm
1,40 mm ± 96 Ø
2 ▽

599.402 ●
91EM 6051BA
6 812 073

→ 0,790 mm
→ 0,890 mm
1,50 mm ± 96 Ø
3 ▽

694.510
91EM 6051CA
6 812 074

→ 0,890 mm
→
1,60 mm ± 96 Ø
4 ▽

109.193
78EM 6584AA
1 576 414



WL
WL-T
4 Cyl. **2499 ccm**
Cyl. 93,0 Ø

Courier
03/1998 → 09/2005
Ranger
10/1999 → 11/2011
Ranger TD
10/1999 → 06/2006

193.130
XM34 6051MA
4 330 744
1,00 mm ± 94 Ø

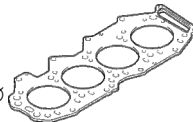

SCB
4 Cyl. **2500 ccm**
Cyl. 92,0 Ø

Scorpio TD
08/1993 → 09/1994

521.339
7 072 599
1,48 mm ± 4x



521.347
7 072 600
1,59 mm ± 2 ▽
4x



521.355
7 072 601
1,69 mm ± 1 ▽
4x



164.861 ●
1,52 mm ± 98 Ø
2 ⊗

























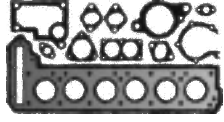
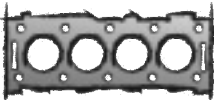

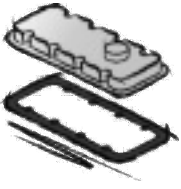

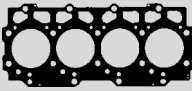

164.841
1,62 mm ± 98 Ø
1 ⊗





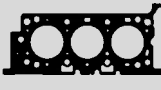

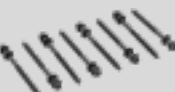















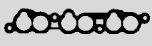

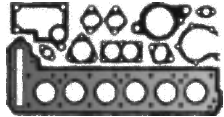
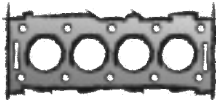

200.941
V94DD 6584BA
7 370 373

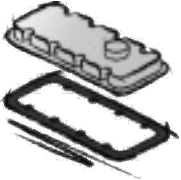
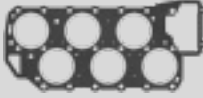

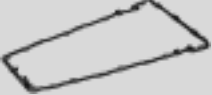
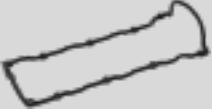
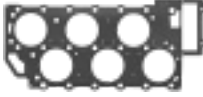

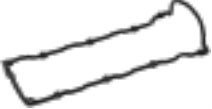

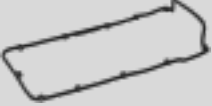











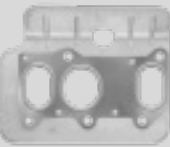

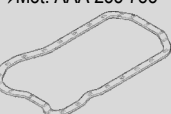

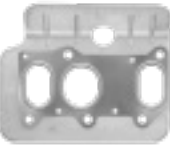







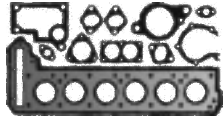
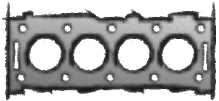

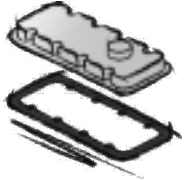





			<p>a) </p> <p>b) </p>	<p>K: </p> <p>N: </p>	
			<p>a) 000.958 78EM 6710BA 1 608 019</p>  <p>b) 813.087 CU C 18x24x2</p>	<p>K:← 040.606 A NBR 45x60x7</p> <p>K:→ 012.507 2x 1 576 425 GRP 65</p>	
			<p>a) 036.164 Dirko HT / EU</p> <p>a) 510.031 Dirko HT / USA/CDN/MEX</p> <p>a) 527.291 Dirko HT / RU</p> <p>a) 648.661 Dirko HT / BR</p>	<p>K:→ 373.490 3 900 720 AS LD FPM 90x110x10</p> <p>K:→ 845.060 AS LD FPM 90x110x8,5</p> <p>N:← 153.830 A LD ACM 32x46x7</p>	
	<p>435.830 7 072 648 4x</p> 	<p>435.810 7 072 649 4x</p> 	<p>a) 036.164 Dirko HT / EU</p> <p>a) 510.031 Dirko HT / USA/CDN/MEX</p> <p>a) 527.291 Dirko HT / RU</p> <p>a) 648.661 Dirko HT / BR</p> <p>b) 877.910 M 22x1,5x10</p> <p>b) 878.040 M 22x1,5x10</p> <p>b) 128.503 1 669 199 CU A 22x27x1,5</p>	<p>K:→ 298.247 ASW LD FPM/ACM 110x130x13</p>	





















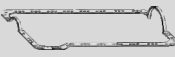

<p>FORD</p> 				
<p>SCC VM</p> <p>4 Cyl. 2500 ccm Cyl. 92,0 Ø</p> <p>Scorpio TD 10/1994 → 08/1998</p>		<p>521.339 7 072 599 1,48 mm $\frac{\pm}{\pm}$ 4x</p>  <p>521.347 7 072 600 1,59 mm $\frac{\pm}{\pm}$ 2 ▽ 4x</p>  <p>521.355 7 072 601 1,69 mm $\frac{\pm}{\pm}$ 1 ▽ 4x</p>  <p>164.861 ● 1,52 mm $\frac{\pm}{\pm}$ 98 Ø 2 ⊗</p>  <p>164.841 1,62 mm $\frac{\pm}{\pm}$ 98 Ø 1 ⊗</p> 		<p>446.111 V95DD 6584AA 1 690 030</p> 
<p>HUBA HUWA HYDA HYDB HYDC JZDA</p> <p>5 Cyl. 2521 ccm Cyl. 83,0 Ø</p> <p>Focus 10/2005 → 09/2012</p> <p>Kuga 02/2008 → 11/2012</p> <p>Mondeo 03/2007 → 01/2015</p> <p>S-Max 05/2006 → 12/2014</p>		<p>477.870 9M5N-6051-AA 1 575 106 0,90 mm $\frac{\pm}{\pm}$</p> 	<p>ZKS 221.490 1 370 338 (12x) M 12x1,75x157</p> 	<p>461.682 EL-Liq 74</p>
<p>LCBA SEA</p> <p>6 Cyl. 2544 ccm Cyl. 82,4 Ø</p> <p>Cougar 08/1998 → 12/2001</p> <p>Mondeo 07/1994 → 09/2000</p>	<p>ES⊕ 027.490 F43X 6014AA 1 005 491 →09/2000</p> <p>ES⊕ 027.680 09/2000→</p> <p>CS* 027.600 F43X 6013AA 1 005 488 +3 780 203</p>	<p>025.120 XU3E 6083AA 3 922 601 L →09/2000</p>  <p>025.070 4 129 205 1S7E 6083DE L 09/2000→</p>  <p>025.130 XU3E 6051AB 4 028 565 R →09/2000</p>  <p>025.090 4 552 600 1S7E 6051DE R 09/2000→</p> 	<p>ZKS 156.580 4 411 018 (8x) M 10x1,5x152,5 2x</p> 	<p>ZKHS 246.090 L</p>  <p>ZKHS 246.100 R</p> 









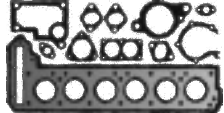
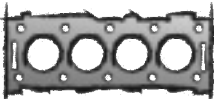

			<p>a) </p> <p>b) </p>	<p>K: </p> <p>N: </p>	
	<p>435.830 7 072 648 4x</p> 	<p>435.810 7 072 649 4x</p> 	<p>a) 036.164 Dirko HT / EU</p> <p>a) 510.031 Dirko HT / USA/CDN/MEX</p> <p>a) 527.291 Dirko HT / RU</p> <p>a) 648.661 Dirko HT / BR</p> <p>b) 877.910 M 22x1,5x10</p> <p>b) 878.040 M 22x1,5x10</p> <p>b) 128.503 1 669 199 CU A 22x27x1,5</p>	<p>K:→ 298.247 ASW LD FPM/ACM 110x130x13</p>	
<p>369.890 1 369 851 FPM 20x</p>	<p>394.320 1 371 948</p> 	<p>302.570 6M5G-9441-AA 1 370 365</p> 	<p>a) 036.164 Dirko HT / EU</p> <p>a) 510.031 Dirko HT / USA/CDN/MEX</p> <p>a) 527.291 Dirko HT / RU</p> <p>a) 648.661 Dirko HT / BR</p> <p>b) 122.904 CU A 18x24x1,5</p>	<p>K:← 336.999 1 431 668 AS RD FPM 35x47x5,6</p> <p>K:→ 135.190 1 369 754 A LD FPM 98x110x8,5</p> <p>N:← 362.730 ASW RD FPM/ACM 45x65x7</p> <p>N:← 362.740 ASW RD FPM 51x65x7</p>	
<p>026.630 F53E 6A517AA 7 221 536 FPM 24x</p>	<p>024.760 XW4E 9448AC 4 503 102 2x</p> 	<p>025.300 F53E 9439BB 3 902 545 2x</p> 	<p>a) 025.460 4 174 016 2R8E 6710AA</p> 	<p>K:← 023.640 F3AE 6700AA 7 117 120 A/BS RD FPM 47,62x63,5x8,9</p> <p>K:→ 287.300 7 104 290 A/BS LD FPM 92,08x107,7x9,65</p> <p>N:→ 340.230 IWD FPM 26x45x23,4</p>	

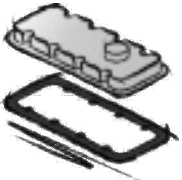
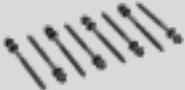





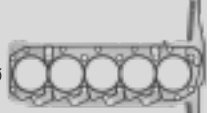
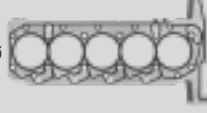
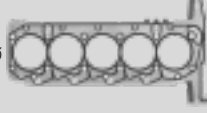

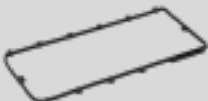





<p>FORD</p> 				
<p>AAA</p> <p>6 Cyl. 2792 ccm Cyl. 81,0 Ø</p> <p>Galaxy 11/1995 → 07/2000</p>	<p>ES⊕ 917.966 95VW 6014AA 7 402 415 →Mot. AAA 146 000</p> <p>ES⊕ 224.460 Mot. AAA 146 001→</p> <p>CS* 617.270 95VW 6013AA 1 005 293</p>	<p>917.908 95VW 6051AA 1 669 794</p> <p>83,5 Ø</p> 	<p>ZKS 104.510 1 669 796 (10x) +1 669 797 (3x) +1 669 795 (7x) M 11x1,5x85/119/144</p> 	<p>917.842 95VW 6584AA 1 669 798 →Mot. AAA 146 000</p>  <p>714.230 1 106 632 Mot. AAA 146 001→</p> 
<p>AMY</p> <p>6 Cyl. 2792 ccm Cyl. 81,0 Ø</p> <p>Galaxy 11/1995 → 04/2000</p>	<p>ES⊕ 726.300</p>	<p>401.820 98VW 6051AA 1 074 620</p> <p>0,64 mm $\frac{1}{16}$ 83,5 Ø</p> 	<p>ZKS 104.510 1 669 796 (10x) +1 669 797 (3x) +1 669 795 (7x) M 11x1,5x85/119/144</p> 	<p>714.230 1 106 632</p> 
<p>AYL</p> <p>6 Cyl. 2792 ccm Cyl. 81,0 Ø</p> <p>Galaxy 04/2000 → 05/2006</p>	<p>ES⊕ 233.740 CS* 217.510</p>	<p>124.634 YM21 6051AA 1 118 007</p> <p>0,64 mm $\frac{1}{16}$ 82,5 Ø</p> 	<p>ZKS 057.290 1118008 (13x) +1118011 (7x) M 11x1,5x101/131</p> 	<p>660.260 1 118 025</p>  <p>037.741 1 333 787 6x</p> 

			<p>a) </p> <p>b) </p>	<p>K: </p> <p>N: </p>	
<p>VAS 825.050 FPM 701.289 95VW 6571BA 1 669 785 FPM 12x</p>	<p>AAS 734.250  917.915 95VW 9448AA 1 005 899  917.958 95VW 9448BA 1 005 900 </p>	<p>917.893 VX021 133227HVX 1 005 062 </p>	<p>a) 616.510 →Mot. AAA 255 785  a) 030.793 Dirko HT Mot. AAA 255 786→ b) 567.640 1 459 212 M 14x1,5x22 b) 878.070 M 14x1,5x16 b) 115.100 95VW 6734AA 1 005 306 0 209 725 CU A 14x20x1,5</p>	<p>K:← 294.357 95VW 6700AA 1 005 301 ASW RD FPM/ACM 35x48x10 K:← 475.961 ASW RD FPM 35x48x10 K:→ 342.093 95VW 6734AA 1 005 303 ASW LD FPM 85x105x11 K:→ 829.056 ASW LD FPM 85x105x11</p>	
<p>VAS 825.050 FPM 701.289 95VW 6571BA 1 669 785 FPM 12x</p>	<p>AAS 734.250  917.915 95VW 9448AA 1 005 899  917.958 95VW 9448BA 1 005 900 </p>	<p>917.893 VX021 133227HVX 1 005 062 </p>	<p>a) 030.793 Dirko HT b) 567.640 1 459 212 M 14x1,5x22</p>	<p>K:← 294.357 95VW 6700AA 1 005 301 ASW RD FPM/ACM 35x48x10 K:← 475.961 ASW RD FPM 35x48x10 K:→ 342.093 95VW 6734AA 1 005 303 ASW LD FPM 85x105x11 K:→ 829.056 ASW LD FPM 85x105x11</p>	
<p>VAS 235.650 FPM 724.590 FPM 24x</p>	<p>124.330 1 118 195  124.340 1 118 196 </p>	<p>225.150 1 119 252 </p>	<p>a) 030.793 Dirko HT b) 567.640 1 459 212 M 14x1,5x22</p>	<p>K:← 155.560 1 100 691 ASW RD PTFE/ACM 35x48x10 K:→ 158.430 1 206 326 ASW LD PTFE 85x105x11</p>	

FORD 					
PR PR4 PR6 6 Cyl. 2792 ccm Cyl. 93,0 Ø Sierra 08/1982 → 12/1986	PR3 PR5	287.785 83TM 6083EB 6 140 741 1,20 mm $\frac{3}{4}$ 95 Ø L 287.777 83TM 6051EB 6 140 740 1,20 mm $\frac{3}{4}$ 95 Ø R	 	580.198 ● 85TM 6584CA 6 153 084 2x	
PRB PRD 6 Cyl. 2792 ccm Cyl. 93,0 Ø Granada 08/1977 → 08/1985	PRC	287.785 83TM 6083EB 6 140 741 1,20 mm $\frac{3}{4}$ 95 Ø L 287.777 83TM 6051EB 6 140 740 1,20 mm $\frac{3}{4}$ 95 Ø R	 	325.449 80TM 6584AA 6 104 534 2x	
PR7 PRE PRI 6 Cyl. 2792 ccm Cyl. 93,0 Ø Scorpio 04/1985 → 11/1986 Sierra 01/1987 → 02/1993	PR8 PRG	287.785 83TM 6083EB 6 140 741 1,20 mm $\frac{3}{4}$ 95 Ø L 287.777 83TM 6051EB 6 140 740 1,20 mm $\frac{3}{4}$ 95 Ø R	 	580.198 ● 85TM 6584CA 6 153 084 2x	
PRN PYU 6 Cyl. 2792 ccm Cyl. 93,0 Ø Capri 01/1981 → 04/1987 Granada 08/1977 → 08/1985	PYA	287.785 83TM 6083EB 6 140 741 1,20 mm $\frac{3}{4}$ 95 Ø L 287.777 83TM 6051EB 6 140 740 1,20 mm $\frac{3}{4}$ 95 Ø R	 	325.449 80TM 6584AA 6 104 534 2x	
PRT 6 Cyl. 2792 ccm Cyl. 93,0 Ø Sierra 08/1982 → 12/1986		287.785 83TM 6083EB 6 140 741 1,20 mm $\frac{3}{4}$ 95 Ø L 287.777 83TM 6051EB 6 140 740 1,20 mm $\frac{3}{4}$ 95 Ø R	 	325.449 80TM 6584AA 6 104 534 2x	

			<p>a) </p> <p>b) </p>	<p>K: </p> <p>N: </p>	
<p>173.053 72TM 6571A1B 6 039 100 NBR 6x</p> <p>206.954 70HM 6571A3B 1 490 525 ACM 6x</p> 	<p>884.561 93TX 9448BA 5 028 770 4x</p> 		<p>a) 761.265 86TM 6710AA 6 134 416 08/1985→</p>  <p>b) 786.500 928M 6734AA 1 454 118 Nylon A 14,5x22x2</p>	<p>K:← 757.497 86HM 6700AA 1 669 254 ASW RD FPM 42x56x7</p> <p>K:→ 693.201 92TM 6701A1A 1 048 572 ASW LD FPM 60,45x76,18x10</p>	
<p>173.053 72TM 6571A1B 6 039 100 NBR 6x</p> <p>206.954 70HM 6571A3B 1 490 525 ACM 6x</p> 	<p>884.561 93TX 9448BA 5 028 770 4x</p> 		<p>b) 786.500 928M 6734AA 1 454 118 Nylon A 14,5x22x2</p>	<p>K:← 757.497 86HM 6700AA 1 669 254 ASW RD FPM 42x56x7</p> <p>K:→ 693.201 92TM 6701A1A 1 048 572 ASW LD FPM 60,45x76,18x10</p>	
<p>173.053 72TM 6571A1B 6 039 100 NBR 6x</p> <p>206.954 70HM 6571A3B 1 490 525 ACM 6x</p> 	<p>884.561 93TX 9448BA 5 028 770 4x</p> 		<p>a) 761.265 86TM 6710AA 6 134 416</p>  <p>b) 786.500 928M 6734AA 1 454 118 Nylon A 14,5x22x2</p>	<p>K:← 757.497 86HM 6700AA 1 669 254 ASW RD FPM 42x56x7</p> <p>K:→ 693.201 92TM 6701A1A 1 048 572 ASW LD FPM 60,45x76,18x10</p>	
<p>173.053 72TM 6571A1B 6 039 100 NBR 6x</p> <p>206.954 70HM 6571A3B 1 490 525 ACM 6x</p> 	<p>884.561 93TX 9448BA 5 028 770 4x</p> 		<p>a) 761.265 86TM 6710AA 6 134 416 05/1985→</p>  <p>b) 786.500 928M 6734AA 1 454 118 Nylon A 14,5x22x2</p>	<p>K:← 757.497 86HM 6700AA 1 669 254 ASW RD FPM 42x56x7</p> <p>K:→ 693.201 92TM 6701A1A 1 048 572 ASW LD FPM 60,45x76,18x10</p>	
<p>173.053 72TM 6571A1B 6 039 100 NBR 6x</p> <p>206.954 70HM 6571A3B 1 490 525 ACM 6x</p> 	<p>884.561 93TX 9448BA 5 028 770 4x</p> 		<p>a) 761.265 86TM 6710AA 6 134 416 08/1985→</p>  <p>b) 786.500 928M 6734AA 1 454 118 Nylon A 14,5x22x2</p>	<p>K:← 757.497 86HM 6700AA 1 669 254 ASW RD FPM 42x56x7</p> <p>K:→ 693.201 92TM 6701A1A 1 048 572 ASW LD FPM 60,45x76,18x10</p>	

<p>FORD</p> 				
<p>MEBA</p> <p>6 Cyl. 2967 ccm Cyl. 89,0 Ø</p> <p>Mondeo 04/2002 → 03/2007</p>			<p>ZKS 156.580 4 411 018 (8x) M 10x1,5x152,5 2x</p> 	<p>ZKHS 246.090 L</p>  <p>ZKHS 246.100 R</p> 
<p>REBA</p> <p>6 Cyl. 2967 ccm Cyl. 89,0 Ø</p> <p>Mondeo 09/2004 → 03/2007</p>			<p>ZKS 156.580 4 411 018 (8x) M 10x1,5x152,5 2x</p> 	<p>ZKHS 246.090 L</p>  <p>ZKHS 246.100 R</p> 
<p>ENSA P5-AT SA2R/S/W</p> <p>5 Cyl. 3198 ccm Cyl. 89,9 Ø</p> <p>Everest 01/2016 → 02/2020</p> <p>Ranger TDCi 04/2011 →</p>	<p>ES⊕ 764.470</p>  <p>CS* 764.750</p>	<p>547.490 BB3Q-6051-A1B 1 776 504 1,10 mm $\frac{\pm}{\text{mm}}$ 91,1 Ø 1 ⊗</p>  <p>547.500 BB3Q-6051-B1B 1 776 505 1,15 mm $\frac{\pm}{\text{mm}}$ 91,1 Ø 2 ⊗</p>  <p>547.510 BB3Q-6051-C1B 1 776 506 1,20 mm $\frac{\pm}{\text{mm}}$ 91,1 Ø 3 ⊗</p> 	<p>ZKS 823.290 1 102 676 (10x) +1 102 674 (12x) M 10x1,5x160 M 8x1,25x121</p> 	<p>928.210 BK3Q-6K260AA 1 760 800</p>  <p>469.690 BK3Q-9T529-AB 1 760 813 ↑ 1x</p> <p>722.080 BK2Q-6K780BA 1 760 803 5x</p>

			<p>a) </p> <p>b) </p>	<p>K: </p> <p>N: </p>	
<p>026.630 F53E 6A517AA 7 221 536 FPM 24x</p>	<p>024.760 XW4E 9448AC 4 503 102 2x</p> 		<p>a) 589.740 4 802 297 3W4E-6710DA</p>  <p>a) 025.460 4 174 016 2R8E 6710AA →10/2003</p> 	<p>K:← 023.640 F3AE 6700AA 7 117 120 A/BS RD FPM 47,62x63,5x8,9</p> <p>K:→ 287.300 7 104 290 A/BS LD FPM 92,08x107,7x9,65</p> <p>N:→ 340.230 IWD FPM 26x45x23,4</p>	
<p>026.630 F53E 6A517AA 7 221 536 FPM 24x</p>	<p>024.760 XW4E 9448AC 4 503 102 2x</p> 		<p>a) 589.740 4 802 297 3W4E-6710DA</p> 	<p>K:← 023.640 F3AE 6700AA 7 117 120 A/BS RD FPM 47,62x63,5x8,9</p> <p>K:→ 287.300 7 104 290 A/BS LD FPM 92,08x107,7x9,65</p> <p>N:→ 340.230 IWD FPM 26x45x23,4</p>	
<p>027.740 XS7Q 6571AD 1 357 589 FPM 20x</p> 	<p>798.310 1 712 448</p>	<p>027.150 XS7Q 8565AA 1 138 392 10x</p> 	<p>a) OWS 876.260</p> <p>a) 036.164 Dirko HT / EU</p> <p>a) 510.031 Dirko HT / USA/CDN/MEX</p> <p>a) 527.291 Dirko HT / RU</p> <p>a) 648.661 Dirko HT / BR</p> <p>b) 012.001 97JM 6730BA 1 013 938 M 14x1,5x20</p> <p>b) 176.090 97JM 6734BA 1 005 593 13x22,4x3</p>	<p>K:← 026.782 1 801 837 ASW RD PTFE 50x90x14</p> <p>K:→ 026.812 3S7Q 6385AB 1 684 287 IWD LD PTFE/ACM 106x215</p>	<p>TLS 764.800</p>

FORD

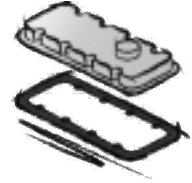
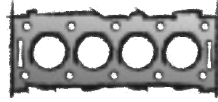
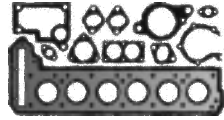

SAFA
5 Cyl. **3198 ccm**
Cyl. 89,9 Ø

Ranger TDCi
04/2011 →

Transit TDCi
09/2007 → 08/2014

ES⊕ **764.470**
Ranger TKE



ES⊕ **866.830**
Transit



CS* **764.750**
Ranger TKE

CS* **907.040**
Transit

777.750
1 459 470
1,10 mm $\frac{3}{4}$ 91 Ø
Transit

547.490
BB3Q-6051-A1B
1 776 504
1,10 mm $\frac{3}{4}$ 91,1 Ø
1 ⊗
Ranger TKE

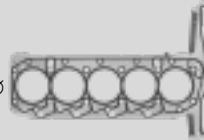

777.820
1 459 471
1,15 mm $\frac{3}{4}$ 91 Ø
Transit

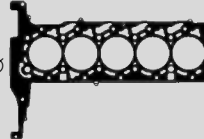

547.500
BB3Q-6051-B1B
1 776 505
1,15 mm $\frac{3}{4}$ 91,1 Ø
2 ⊗
Ranger TKE

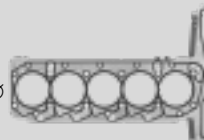

777.850
1 459 472
1,20 mm $\frac{3}{4}$ 91 Ø
Transit

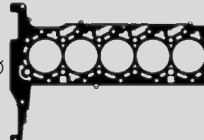

547.510
BB3Q-6051-C1B
1 776 506
1,20 mm $\frac{3}{4}$ 91,1 Ø
3 ⊗
Ranger TKE

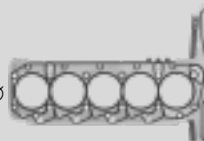

ZKS 823.290
1 102 676 (10x)
+1 102 674 (12x)
M 10x1,5x160 M
8x1,25x121



ZKHS 939.080
Transit
476.620
Transit

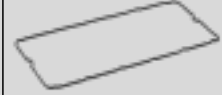

928.210
BK3Q 6K260AA
1 760 800
Ranger TKE

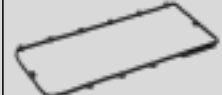

469.690
BK3Q-9T529-AB
1 760 813
↑
Ranger TKE
1x

722.080
BK2Q-6K780BA
1 760 803
Ranger TKE
5x

177.700
6C1Q 6K780AB
1 372 494
Transit
5x



SAFB
5 Cyl. **3198 ccm**
Cyl. 89,9 Ø

Transit TDCi
09/2007 → 08/2014

ES⊕ **866.830**
Transit



CS* **907.040**
Transit

777.750
1 459 470
1,10 mm $\frac{3}{4}$ 91 Ø
Transit

777.820
1 459 471
1,15 mm $\frac{3}{4}$ 91 Ø
Transit

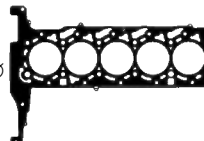

777.850
1 459 472
1,20 mm $\frac{3}{4}$ 91 Ø
Transit

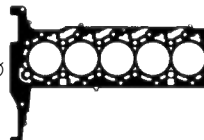

ZKS 823.290
1 102 676 (10x)
+1 102 674 (12x)
M 10x1,5x160 M
8x1,25x121

















ZKHS 939.080
Transit
476.620
Transit



177.700
6C1Q 6K780AB
1 372 494
Transit
5x



			<p>a) </p> <p>b) </p>	<p>K: </p> <p>N: </p>	
<p>027.740 XS7Q 6571AD 1 357 589 FPM 20x</p> 	<p>798.310 1 712 448</p>	<p>027.150 XS7Q 8565AA 1 138 392 10x</p> 	<p>a) OWS 876.260</p> <p>a) 036.164 Dirko HT / EU</p> <p>a) 510.031 Dirko HT / USA/CDN/MEX</p> <p>a) 527.291 Dirko HT / RU</p> <p>a) 648.661 Dirko HT / BR</p> <p>b) 012.001 97JM 6730BA 1 013 938 M 14x1,5x20</p> <p>b) 176.090 97JM 6734BA 1 005 593 13x22,4x3</p>	<p>K:← 026.782 1 801 837 ASW RD PTFE 50x90x14</p> <p>K:→ 026.812 3S7Q 6385AB 1 684 287 IWD LD PTFE/ACM 106x215</p>	<p>TLS 764.800 Ranger TKE</p> <p>TLS 939.090 Transit</p> 
<p>027.740 XS7Q 6571AD 1 357 589 FPM 20x</p> 	<p>798.310 1 712 448</p>	<p>027.150 XS7Q 8565AA 1 138 392 10x</p> 	<p>a) OWS 876.260</p> <p>a) 036.164 Dirko HT / EU</p> <p>a) 510.031 Dirko HT / USA/CDN/MEX</p> <p>a) 527.291 Dirko HT / RU</p> <p>a) 648.661 Dirko HT / BR</p> <p>b) 012.001 97JM 6730BA 1 013 938 M 14x1,5x20</p> <p>b) 176.090 97JM 6734BA 1 005 593 13x22,4x3</p>	<p>K:← 026.782 1 801 837 ASW RD PTFE 50x90x14</p> <p>K:→ 026.812 3S7Q 6385AB 1 684 287 IWD LD PTFE/ACM 106x215</p>	<p>TLS 939.090 Transit</p> 



000.162	563
000.958	1131, 1141, 1143
001.563	1082, 1112, 1118, 1128, 1134, 1136
002.131	624
002.141	626
002.360	9, 637, 837, 839
002.440	867
002.490	637, 867
004.441	794
004.450	419, 685, 689, 691, 699, 721, 723, 725
005.510	518, 520, 522, 524
005.610	218
005.660	8, 636, 838
005.911	148, 648
006.522	20
006.600	652
006.702	38
006.970	1125
007.030	23, 41, 613, 617, 619, 621, 947
007.041	612, 616
007.051	947
007.210	1128
007.810	9, 587, 637, 691, 859, 861
007.870	95, 97, 155, 159
007.961	562
008.040	124, 126, 188, 190, 192, 194, 196, 368
008.170	9, 637, 837, 839
008.430	415, 457, 459
008.560	546, 550
008.822	24, 26, 28, 30, 910, 912, 914, 916, 918
008.832	24, 26, 28, 30, 910, 912, 914, 916, 918
008.860	220, 224
010.051	1018, 1028, 1034
010.120	704
010.230	416, 418, 428, 444, 446, 448
010.270	661
010.350	614
010.360	817
012.001	641, 643, 659, 777, 885, 887, 895, 947, 995, 997, 999, 1001, 1003, 1005, 1007, 1009, 1011, 1013, 1017, 1019, 1029, 1031, 1033, 1035, 1039, 1045, 1047, 1049, 1051, 1053, 1055, 1057, 1059, 1061, 1063, 1065, 1067, 1071, 1073, 1075, 1077, 1079, 1081, 1083, 1093, 1095, 1099, 1101, 1107, 1109, 1111, 1113, 1123, 1125, 1127, 1129, 1133, 1135, 1151, 1153
012.220	684
012.280	641, 643, 887
012.370	77, 79, 105, 107, 111, 113, 115, 117, 135, 137, 141, 143, 145, 147, 151, 185, 187, 363, 365, 1087, 1089, 1091
012.380	89, 91, 185
012.507	1131, 1141, 1143
013.920	1030, 1034
016.030	1096, 1098
016.049	1096, 1098
017.131	353
017.980	240, 268, 270, 272, 274, 276



018.000	240, 268, 270, 272, 274, 276
018.010	240, 268, 270, 272, 274, 276
018.050	240, 268, 270, 272, 274, 276
018.060	240, 268, 270, 272, 274, 276
018.070	240, 268, 270, 272, 274, 276
018.352	694
019.140	731, 955, 957
019.321	452, 454
019.331	452, 454
020.020	795, 797
021.660	532
022.170	813, 815, 817, 819
022.670	816
023.401	714, 726
023.520	811, 1001, 1003, 1009, 1011, 1013, 1031, 1033, 1035
023.540	715, 727, 767, 895, 939
023.551	1000, 1008
023.590	1001, 1003, 1009, 1011, 1013, 1017, 1019, 1029, 1031, 1033, 1035
023.631	1083, 1111, 1113, 1115, 1117, 1119, 1129, 1135, 1137
023.640	1137, 1139, 1145, 1151
023.660	1000, 1008
023.680	715, 727, 767, 895, 939
023.711	714, 726, 764
023.740	999, 1005, 1045
023.862	1001, 1003, 1009, 1011, 1013, 1017, 1019, 1029, 1031, 1033, 1035
023.940	1083, 1111, 1113, 1115, 1117, 1119, 1129, 1135, 1137
023.950	999, 1005, 1045
023.990	614
024.081	658
024.352	416, 418, 428, 444, 446, 448
024.390	1083, 1113, 1129, 1135
024.760	1137, 1139, 1145, 1151
024.940	1003, 1011, 1031
024.950	1005, 1045
024.961	1002, 1010
024.999	1044
025.000	1004
025.030	1000, 1002
025.040	1000
025.070	1136, 1138, 1144
025.090	1136, 1138, 1144
025.120	1136, 1138, 1144
025.130	1136, 1138, 1144
025.250	1045
025.260	1003, 1009, 1011, 1013, 1031, 1033
025.271	999, 1005
025.280	1001, 1009
025.290	1001
025.300	1137, 1139, 1145
025.450	1001, 1009, 1011, 1031
025.460	1137, 1139, 1145, 1151
025.481	999, 1005, 1045
025.510	1002, 1010



025.890	1078
026.450	570
026.540	998, 1004, 1044
026.551	1082, 1112, 1128
026.630	1137, 1139, 1145, 1151
026.640	999, 1005, 1045
026.650	641, 643, 885, 887, 895, 1083, 1111, 1113, 1115, 1117, 1119, 1129, 1135, 1137
026.670	1001, 1003, 1009, 1011, 1013, 1019, 1029, 1031, 1033, 1035
026.680	1083, 1111, 1113, 1115, 1117, 1119, 1129, 1135, 1137
026.700	1001, 1003, 1009, 1011, 1013, 1019, 1029, 1031, 1033, 1035
026.740	699, 701, 703, 707, 709, 711, 713, 877, 1015, 1017, 1019, 1021, 1025, 1027
026.750	699, 701, 703, 707, 709, 711, 713, 725, 745, 877, 1015, 1017, 1019, 1021, 1025, 1027
026.770	1047, 1049, 1051, 1053, 1055, 1077
026.782	777, 947, 1107, 1109, 1111, 1123, 1125, 1127, 1133, 1151, 1153
026.790	217, 225, 241, 243, 265, 267, 269, 271, 273, 275, 277, 279, 315, 317, 319, 321, 323, 325, 329, 333, 335, 337, 341, 343, 345, 347, 349, 353, 373, 375, 377, 379, 381, 383, 385, 699, 701, 703, 707, 709, 711, 713, 877, 1015, 1017, 1019, 1021, 1025, 1027
026.812	777, 947, 1107, 1109, 1111, 1123, 1125, 1127, 1133, 1151, 1153
026.821	1047, 1049, 1051, 1053, 1055, 1075, 1077
026.910	1004
026.961	1107, 1109, 1111
026.980	1109, 1111, 1123
026.990	1107, 1109
027.062	1046, 1048, 1050, 1052, 1054, 1076
027.072	1046, 1048, 1050, 1052, 1054, 1076
027.082	1046, 1048, 1050, 1052, 1054, 1076
027.092	1046, 1048, 1050, 1052, 1054, 1076
027.102	1046, 1048, 1050, 1052, 1054, 1076
027.112	1046, 1048, 1050, 1052, 1054, 1076
027.150	777, 947, 1107, 1109, 1111, 1123, 1125, 1127, 1133, 1151, 1153
027.160	701, 1015
027.170	698, 700, 706, 708, 710, 876, 1014, 1016, 1018, 1020, 1024, 1026
027.270	1082
027.291	1082, 1112, 1128
027.330	1047, 1049, 1051, 1053, 1055, 1077
027.371	777, 947, 1107, 1109, 1111, 1123, 1125, 1127, 1133
027.470	1112, 1128
027.490	1136, 1138, 1144
027.570	1046, 1048, 1050, 1052, 1054, 1056, 1058, 1064, 1074, 1076
027.600	1136, 1138, 1144
027.680	1136, 1138, 1144
027.720	776, 946, 1106, 1108, 1110, 1122, 1124, 1132
027.730	700, 1014
027.740	777, 947, 1107, 1109, 1111, 1123, 1125, 1127, 1133, 1151, 1153



027.750	699, 701, 707, 709, 713, 877, 1015, 1017, 1019, 1021, 1027
027.850	1046, 1048, 1050, 1052, 1054, 1076
027.890	1012
027.990	914
028.000	914
028.020	914
028.030	914
028.040	914
028.230	1082, 1112, 1128, 1134, 1136
029.350	546
030.440	998, 1004, 1044
030.460	1046, 1076
030.470	1044
030.492	1046, 1048, 1076
030.500	1048, 1050, 1052, 1054
030.521	1050, 1052
030.531	1054
030.551	1106, 1108, 1110, 1122
030.583	1108, 1110
030.602	1108
030.612	1106, 1108
030.652	1132
030.662	1132
030.760	700, 1014
030.780	700, 710, 876, 1014, 1024
030.793	9, 11, 13, 15, 17, 19, 21, 23, 25, 27, 29, 31, 33, 35, 37, 39, 41, 43, 45, 69, 71, 73, 75, 77, 79, 81, 89, 91, 93, 95, 97, 99, 101, 103, 105, 107, 109, 111, 113, 115, 117, 123, 125, 127, 131, 133, 135, 137, 139, 141, 143, 145, 147, 149, 151, 153, 155, 157, 159, 161, 163, 165, 167, 169, 171, 173, 175, 177, 185, 187, 189, 191, 193, 195, 197, 199, 209, 211, 213, 215, 217, 219, 221, 223, 225, 227, 231, 233, 235, 237, 239, 241, 243, 245, 251, 257, 259, 261, 263, 265, 267, 269, 271, 273, 275, 277, 279, 281, 283, 285, 287, 289, 291, 293, 295, 297, 299, 301, 303, 305, 307, 309, 311, 313, 315, 317, 319, 321, 323, 325, 327, 329, 331, 333, 335, 337, 339, 341, 343, 345, 347, 349, 353, 355, 361, 363, 365, 367, 369, 371, 373, 375, 377, 379, 381, 383, 385, 421, 437, 439, 441, 443, 449, 451, 453, 455, 505, 507, 637, 639, 641, 643, 645, 647, 649, 691, 795, 837, 839, 841, 843, 845, 847, 849, 851, 853, 855, 857, 859, 861, 865, 867, 869, 871, 873, 881, 883, 885, 887, 893, 895, 903, 905, 907, 909, 911, 913, 915, 917, 919, 921, 925, 927, 929, 931, 933, 935, 937, 939, 941, 947, 953, 955, 957, 1087, 1089, 1091, 1121, 1147
032.900	369
033.070	197
033.891	501
034.540	661
034.550	552
034.560	643, 651, 653, 655, 763, 779, 953
035.670	69, 71
035.850	173, 175
036.164	332, 334, 409, 411, 413, 419, 461, 463, 465, 467, 469, 527, 529, 571, 581, 583, 585, 587, 589, 591, 593, 595, 597, 599, 601, 603, 607, 609, 613, 615, 617, 619, 621, 623, 643, 651, 653, 655, 657, 661, 663, 665, 685, 689, 691,



036.355	40
036.365	40
036.375	40
036.920	177
036.940	167, 169, 173
036.980	169, 175
037.461	14, 636, 844, 866, 868, 1000
037.741	324, 1146
040.050	210, 212, 214, 232, 234, 236, 238, 250, 252, 258, 260, 262, 264, 370, 376
040.060	416, 426, 428
040.320	1131, 1141
040.331	23, 41
040.554	14, 636, 844, 846, 848, 850, 852, 866, 868, 1000
040.606	1131, 1141, 1143
040.860	612
041.450	197, 199
044.611	751, 755, 757, 759, 761, 775, 935, 937
047.190	1125
047.221	8, 636, 838
048.800	281, 283, 287, 289, 291, 293, 295, 297
049.930	87, 89, 91, 143, 181, 183, 1089
050.191	797
050.260	421, 431, 435, 437, 471, 481, 483, 485, 487, 489, 495, 497, 499, 533, 563
050.380	1111
050.460	1111
051.980	340, 342
052.091	1124
052.100	776, 946, 1124, 1132
052.110	1107, 1109, 1111, 1133
052.120	340, 342
054.930	414, 456, 458
056.130	23, 41, 583, 593, 595, 607, 613, 615, 617, 619, 621, 623, 625, 627, 629, 947, 1113, 1115, 1117, 1119, 1135, 1137
056.900	23, 593, 601, 603, 883, 895
057.070	211, 213, 215, 233, 235, 237, 239, 251, 253, 259, 261, 263, 265, 313, 371, 377, 379
057.220	92
057.240	142, 144, 146, 148, 150, 1086, 1088
057.260	76, 78
057.290	1146
057.370	655, 657, 659, 661, 663
057.410	184



057.440	182
057.450	312, 378
057.510	1090
057.670	178, 180, 182, 184
058.051	510
058.053	510, 512
058.141	510
058.143	510, 512
058.191	510
058.193	510, 512
058.221	510
058.223	510, 512
058.671	728, 730
058.701	728, 730
058.841	728, 730
058.880	604, 606, 610, 612, 614, 616, 618
058.981	728, 730
059.031	734, 736, 900, 902
059.041	734, 736, 900, 902
059.171	734, 736, 900, 902
059.201	734, 736, 900, 902
059.341	734, 736, 900, 902
060.062	488, 496, 508, 510, 512
060.161	1139
061.151	40, 954
061.161	40, 954
061.171	40, 954
061.760	23, 593, 601, 603, 883, 895
063.110	959
065.730	614
065.810	68, 70
066.391	431, 445, 489, 497, 509
066.650	513
067.910	613
067.920	613
068.081	612
068.181	594
068.190	594
068.616	417, 419, 421, 429, 445, 447, 449, 459
069.320	814, 818
069.331	814, 816, 818
069.390	814, 816, 818
069.440	815, 817, 819
069.460	815, 817, 819
069.470	815, 817, 819
069.490	810
069.530	810
069.540	11, 13, 15, 637, 639, 843, 845, 849, 851, 853, 865, 867, 869, 871, 873, 1001
069.550	811, 813
069.590	9, 15, 17, 19, 21, 23, 25, 27, 29, 31, 33, 35, 37, 39, 41, 43, 607, 609, 637, 639, 641, 643, 645, 647, 649, 837, 839, 841, 875, 883, 885, 887, 893, 903, 905, 907, 909, 911, 913, 915, 917, 919, 921, 925, 927, 937, 939, 953, 955, 957
069.600	15, 637, 843, 845, 847, 849, 851, 853, 867, 869, 1001



069.630	11, 13, 15, 637, 639, 843, 849, 853, 865, 867, 869, 871, 873
069.640	811
069.670	811
071.292	802
071.340	445
072.850	623, 625, 627
073.611	532
073.890	799, 801, 803
073.910	445, 509, 513
074.173	8, 10, 584, 586, 636, 690, 854, 856, 858, 860, 1004
074.391	686
074.400	210, 214
074.410	532
074.460	533
074.530	532
074.550	532
074.660	30, 904
074.670	30, 904
074.990	431, 445, 489, 497, 509, 511, 513
075.400	747
075.820	750, 754, 756, 758, 760, 934, 936
075.830	750, 754, 756, 758, 760, 934, 936
075.840	750, 754, 756, 758, 760, 934, 936
075.850	750, 754, 756, 758, 760, 934, 936
075.860	750, 754, 756, 758, 760, 934, 936
075.870	750, 754, 756, 758, 760, 934, 936
075.880	750, 754, 756, 758, 760, 934, 936
075.890	750, 754, 756, 758, 760, 934, 936
075.920	430
075.950	430
075.960	430
076.040	727, 763, 765, 941
076.110	73, 93
076.220	725, 747, 761, 779, 929
076.348	8, 10, 584, 586, 636, 690, 854, 856, 858, 860, 1004
076.358	8, 10, 584, 586, 636, 690, 854, 856, 858, 860, 1004
076.408	8, 10, 584, 586, 636, 690, 854, 856, 858, 860, 1004
076.892	22, 592, 600, 602, 894
076.971	603
077.363	411, 413
077.382	409
077.394	419, 461, 463, 465, 467, 469
077.402	411, 413
077.413	411
080.990	107, 115, 117, 363
081.500	946
081.540	782, 958, 962, 964
081.581	612
083.350	664, 666
085.550	419, 463, 467, 469
085.560	467
085.800	590
086.420	299, 303, 305



086.887	82, 84
087.240	467, 469
087.262	994, 996, 998, 1000, 1006, 1008
087.270	467
087.830	1000, 1002, 1008, 1010, 1012, 1016, 1018, 1028, 1030, 1032, 1034
090.860	810
090.970	727, 765, 941
091.110	810
091.180	811
092.160	811
092.170	811, 813
094.190	166, 168, 174, 176
100.141	559, 561
100.400	700, 1014
100.410	700, 1014
100.420	700, 1014
100.430	700, 1014
100.440	700, 1014
100.470	562
100.520	562
102.260	902
102.823	995, 999, 1007
103.706	995, 999, 1007
103.960	995, 997, 999, 1001
104.270	880, 882
104.280	1006, 1008
104.316	842, 852
104.380	657, 663
104.510	1146
104.580	662
104.600	662
104.604	864
104.610	663
104.630	663
104.930	100, 102, 104, 106, 108, 110, 112, 114, 360
107.256	149, 199, 201, 203, 205, 217, 219
108.502	699, 701, 703, 707, 709, 711, 713, 733, 747, 755, 757, 759, 761, 771, 773, 877, 897, 929, 937, 945, 1015, 1017, 1019, 1021, 1025, 1027, 1105, 1121
108.540	655, 657, 659, 661, 663
109.193	1130, 1140, 1142
110.290	570
110.300	570
110.320	570
110.353	345, 349
110.507	409, 411, 413, 419, 437, 439, 441, 443, 461, 463, 465, 467, 469, 501, 505, 507, 527, 529
110.604	9, 11, 13, 15, 637, 639, 663, 837, 839, 841, 865, 867, 869, 871, 873
110.906	415, 417, 419, 421, 429, 431, 435, 437, 445, 447, 449, 451, 453, 455, 457, 459, 471, 473, 475, 481, 483, 485, 487, 489, 491, 493, 495, 497, 499, 501, 509, 511, 513, 515, 517, 519, 521, 523, 525, 527, 531, 533, 535, 537, 539, 541, 543, 553, 555, 557, 559, 563, 565
111.104	33
111.460	804



111.590	10, 12, 14, 636, 638, 842, 848, 852, 864, 866, 868, 870, 872
112.000	1139, 1141
115.100	73, 83, 85, 87, 89, 93, 119, 121, 127, 129, 131, 133, 135, 137, 139, 141, 145, 149, 177, 179, 181, 183, 185, 199, 201, 203, 205, 207, 209, 217, 219, 229, 233, 247, 253, 255, 259, 589, 591, 595, 597, 599, 601, 605, 607, 609, 611, 613, 615, 617, 619, 653, 657, 659, 663, 665, 1085, 1087, 1091, 1147
116.580	736, 738, 740, 898, 900, 902
117.772	684
117.831	686, 692, 694, 696, 864
118.051	798
120.782	655, 657, 659, 661, 663
121.590	623, 625, 627, 661
121.610	285, 301, 309
121.740	623, 625, 661
122.121	1132
122.505	419, 541, 543, 545, 547, 549, 551, 553, 559, 561
122.904	1145
123.022	784, 786, 966
123.032	784, 786, 966
123.483	1092, 1094
123.590	444
123.601	784, 966
123.611	784, 966
123.651	786
123.661	786
123.671	786
123.681	786
123.740	444
123.992	134, 136, 140, 142
124.002	134, 136, 140, 142
124.012	134, 136, 140, 142
124.330	1147
124.340	1147
124.372	947
124.474	88, 90
124.634	1146
125.022	1002
125.042	1030
125.800	958
125.850	958
125.911	746, 760, 928
127.490	1037, 1039, 1079, 1081, 1093, 1095
127.510	1037, 1039, 1079, 1081, 1093, 1095
127.610	23, 39, 41, 585, 589, 591, 613, 617, 619, 621, 643, 651, 653, 655, 763, 779, 947, 953
128.162	1047, 1049, 1051, 1053, 1055, 1057, 1059, 1061, 1063, 1065, 1067, 1069, 1071, 1073, 1075, 1077
128.210	423, 425
128.220	202
128.270	202
128.503	43, 45, 779, 783, 785, 787, 789, 949, 951, 953, 955, 957, 959, 961, 963, 965, 967, 969, 1143, 1145

elring Das Original	
129.780	71, 77, 79, 89, 91, 95, 97, 101, 103, 105, 107, 109, 111, 113, 115, 117, 135, 137, 139, 141, 143, 145, 147, 149, 151, 153, 185, 187, 211, 213, 215, 233, 235, 237, 239, 261, 263, 265, 361, 363, 365, 377, 649, 1087, 1089, 1091
129.800	1006, 1008
129.900	762, 764, 940
129.950	726
130.110	222, 240, 242, 268, 270, 272, 274, 276, 278, 372, 374
130.120	326, 328, 336, 338
130.130	341, 343, 345, 347, 349, 385
130.270	662
130.280	662
130.360	662
130.370	662
130.642	732, 896
130.652	732, 896
130.662	732, 896
130.672	732, 896
130.682	732, 896
130.692	732, 896
130.712	732, 896
130.722	732, 896
130.732	732, 896
130.742	732, 896
130.830	104, 106, 110, 112, 114, 116, 362
130.850	210, 212, 214, 232, 234, 236, 238, 250, 252, 258, 260, 262, 264, 370, 376
131.660	458
132.130	589
133.051	101, 103, 109, 111, 113, 201, 203, 209, 229, 233, 247, 259
133.520	91
135.052	748, 752, 772, 774, 928, 930, 932, 944, 1102
135.072	748, 752, 772, 774, 928, 930, 932, 944, 1102
135.110	9, 637, 685, 687, 693, 695, 697, 705, 717, 719, 837, 839, 841, 865
135.140	715, 717, 719, 785, 787, 967
135.190	1145
135.230	73, 93
135.280	718
135.291	686
135.391	426, 428
135.531	580
135.600	543, 547, 549
136.271	580
136.690	725, 747, 779, 929
136.940	749, 751, 753, 755, 757, 759, 761, 773, 775, 929, 931, 933, 935, 937, 945, 1103
137.130	662
137.285	86, 88
137.681	660
137.761	660
137.771	661
138.111	420
138.121	420
138.131	420
138.310	727, 765

elring Das Original	
138.430	805
141.921	780
141.931	694
143.031	890, 922
143.041	890, 922
143.071	920
143.180	956, 960
143.231	956
143.261	956
143.280	954
143.291	954, 960
143.300	954, 960
143.930	783, 785, 955, 957, 959, 961, 963, 965, 967
144.140	874
144.150	714, 878, 880
144.281	874
144.291	878
144.340	862
144.350	874
144.420	836, 838
144.440	838
144.460	836
144.470	840, 842, 844
144.520	836
144.552	840, 842
144.570	836
144.750	650
146.587	489
146.593	489
147.001	768, 942
147.011	768, 942
147.021	768, 942
147.031	768, 942
147.041	768, 942
147.360	430, 472
147.522	738, 740, 898
147.532	738, 740, 898
147.542	738, 740, 898
147.552	738, 740, 898
147.562	738, 740, 898
147.581	435, 437, 481, 483, 485, 495, 497, 531
147.590	435, 437, 481, 483, 485, 495, 497, 531
147.600	480, 482, 494, 496
147.610	432, 434, 476, 478, 480, 494, 502, 530
148.110	836, 838, 840
148.190	101, 103, 105, 107, 109, 111, 113, 115, 117, 361, 363
148.230	785, 787, 967
148.271	241, 243, 269, 271, 273, 275, 277, 279, 337, 375
148.331	72
149.080	337
149.302	336
149.312	336
149.324	336
149.332	336
149.342	336

elring Das Original	
149.354	336
149.360	725, 727, 745, 747, 761, 765, 779, 929, 941
149.720	184
149.992	76, 78
150.011	76, 78
150.021	76, 78
150.111	147, 151
150.153	142, 144, 146, 148, 1086, 1088, 1090
150.162	142, 144, 146, 148, 1086, 1088, 1090
150.172	142, 144, 146, 148, 1086, 1088, 1090
150.380	148, 150, 152, 648
150.390	148, 150, 152, 648
150.400	148, 150, 152, 648
150.782	150
150.791	150
150.801	150
150.860	123, 125, 185, 187, 189, 365, 367
150.891	327
150.902	327
151.123	326
151.140	73, 75, 93, 95
151.611	22, 40
151.690	23, 41
151.810	803
151.890	802
151.900	489, 497, 509, 513
151.960	508
152.060	508
152.080	18, 20, 36, 38, 892
152.090	936, 938, 956
152.307	726, 764, 940
152.317	726, 764, 940
152.390	489, 497, 509, 511, 513
152.440	22, 24, 28, 30, 902, 904, 906, 908, 910, 912, 914, 916, 918, 920
152.480	778
152.510	780
152.550	728, 730, 732, 734, 736, 762, 764, 766, 896, 900, 902, 938, 940
152.570	784, 786, 966
152.760	40, 42, 952
153.002	748, 752, 772, 774, 928, 930, 932, 944, 1102
153.142	748, 752, 772, 774, 928, 930, 932, 944, 1102
153.200	724
153.740	743, 745, 747, 749, 751, 753, 755, 757, 759, 761, 771, 773, 775, 929, 931, 933, 935, 937, 945, 1103, 1105, 1121
153.830	1143
154.016	836, 838
154.170	752, 772, 774, 930, 944
154.980	434, 436, 470
155.560	71, 73, 75, 77, 79, 89, 91, 95, 97, 105, 107, 111, 113, 115, 117, 135, 137, 141, 143, 145, 147, 149, 151, 153, 155, 157, 159, 185, 187, 211, 213, 215, 233, 235, 237, 239, 259, 261, 263, 265, 313, 325, 363, 365, 371, 377, 379, 649, 1087, 1089, 1091, 1147
155.710	727, 765
155.720	727, 765, 941



155.740	749, 751, 753, 755, 757, 759, 761, 773, 775, 929, 931, 933, 935, 937, 945, 1103
155.750	725, 727, 745, 747, 761, 765, 779, 929, 941
156.201	776, 946, 1122, 1124, 1126
156.211	776, 946, 1122, 1124, 1126
156.221	776, 946, 1122, 1124, 1126
156.550	998, 1004, 1044
156.580	1136, 1138, 1144, 1150
156.680	734, 762
156.770	749, 753, 773, 775, 929, 931, 933, 945, 1103
156.830	328, 348, 350
156.870	328, 348, 350
157.200	805
157.410	496
157.420	496
157.430	496
157.440	496
157.480	488
157.490	488
157.560	431, 445, 489, 509, 511, 513
157.570	488, 496
157.680	488, 496, 508, 510, 512
158.060	73, 93
158.352	602
158.382	602
158.412	602
158.430	325, 327, 355, 1147
159.714	795, 797
159.730	444
160.720	715, 727, 895
162.141	780
162.483	704
163.480	745, 771, 1105
163.520	101, 103, 109, 111, 113
164.241	1056, 1060, 1064, 1066, 1070, 1074
164.261	1058, 1062, 1064, 1066, 1072, 1074
164.271	1058, 1062, 1064, 1066, 1072, 1074
164.320	198, 200, 202
164.341	611, 615
164.350	614
164.841	656, 1142, 1144
164.861	656, 1142, 1144
164.991	134, 136, 140
165.011	134, 136, 140
165.041	134, 136, 140
165.210	89
165.510	795, 797
165.560	591, 595, 599, 601
165.580	595, 599
165.590	591, 595, 599, 601
165.980	744
166.160	571, 581, 583
166.180	581, 583
166.190	571, 581, 583, 881
166.210	581
166.240	581



166.260	430
167.180	512
167.621	598
167.770	72
167.881	629
167.911	616, 618, 620
169.620	795, 797
169.650	795, 797
170.051	778
171.480	511
172.440	720
172.870	184
172.891	436, 438, 440, 442
173.011	436, 438, 440, 442
173.021	436, 438, 440, 442
173.053	1149
173.700	776, 946, 1124, 1132
173.890	333, 335, 341, 343, 345, 347, 353, 383, 385, 563, 565
174.020	340, 342, 344, 346, 348, 384
174.030	340, 342, 344, 346, 348, 384
174.251	598
174.981	699, 723
175.143	653
175.580	1106, 1108, 1110, 1122, 1132
176.090	641, 643, 659, 777, 885, 887, 895, 947, 995, 997, 999, 1001, 1003, 1005, 1007, 1009, 1011, 1013, 1017, 1019, 1029, 1031, 1033, 1035, 1039, 1045, 1047, 1049, 1051, 1053, 1055, 1057, 1059, 1061, 1063, 1065, 1067, 1071, 1073, 1075, 1077, 1079, 1081, 1083, 1093, 1095, 1099, 1101, 1107, 1109, 1111, 1113, 1123, 1125, 1127, 1129, 1133, 1135, 1151, 1153
176.450	570
176.510	570
176.560	571
176.570	571
176.920	580
176.930	727, 763, 765
177.110	716
177.230	794, 796
177.700	776, 946, 1124, 1132, 1152
178.580	184, 186, 364
180.000	22, 24, 30, 904, 906, 908, 910
180.060	22, 24, 30, 904, 906, 908, 910
180.100	40
180.140	838, 840
180.180	840, 842, 844
180.190	844
180.230	844
180.250	850, 852
180.260	850, 852
180.270	848, 852
180.380	848
180.390	852
180.400	852
180.490	14
180.500	14



180.520	14
180.540	14
180.560	892
180.570	18, 20, 38
180.600	18, 20, 38
180.610	892
180.620	892
180.630	936
180.640	936
180.650	42, 952
180.730	42, 952
180.770	36, 38
180.890	38
180.900	38
180.910	38
180.970	36, 38
180.980	36, 38
181.000	44
181.010	784, 966
181.060	784, 966
181.070	784, 966
181.110	784, 966
181.150	784, 966
181.260	964
181.270	782, 784, 962, 964
181.320	782, 784, 962, 964
181.340	765, 941
181.380	727
181.460	626
181.850	512
182.010	764
182.020	940
182.050	764, 940
182.130	816
182.310	726
182.320	726
182.330	726
183.160	726
183.411	764, 940
183.860	178, 180, 182, 184
183.890	100, 102, 104, 106, 108, 110, 114, 360
184.050	208, 226, 228, 230, 232, 244, 254, 256, 258
184.742	936
184.921	42, 952
184.931	42, 952
184.951	42, 952
186.030	500
186.231	902
186.381	902
186.421	902
186.532	30, 904
186.542	30, 904
186.552	30, 904
187.390	128
187.400	128, 130, 132, 138, 144, 1084, 1086, 1090
187.666	423, 425, 475

elring		Das Original	
187.690			952
187.710			952
189.380		94, 96, 152, 154, 156, 158	
189.768			879
190.440			488
190.640		417, 419, 421, 429, 445, 447, 449, 459	
191.420			641
191.440			544
191.450			560
191.530			540
191.640			1010
191.965			863
193.130			1142
193.222			694
193.713		1029, 1043, 1097, 1099	
194.020			794
195.670		73, 87, 93, 119, 121	
196.140		1030, 1034	
196.150			1030
196.180		581, 583, 585	
196.200			324
196.390			147, 151
196.600			337, 339
196.620			79
197.680			626
197.690			628
198.240		1036, 1038, 1078, 1080, 1092, 1094	
198.410			202, 204
198.624			542
198.660			488
198.680			880
198.720			881
198.770		417, 419, 429, 445, 447, 449, 541, 543, 545, 547, 549, 551, 553, 559, 561	
198.850			938, 956
198.860			782
198.870			882
198.880			882
198.890			882
198.900			964
198.910			882
198.920			882
198.930			782
198.950			938
199.000		844, 846, 850, 852	
199.010		10, 12, 14, 636, 638, 842, 848, 852, 864, 866, 868, 870, 872	
199.020			14, 18, 20, 38
199.030		22, 24, 30, 904, 906, 908, 910	
199.040			40
199.050			42, 952
199.060		782, 784, 962, 964, 966	
199.080		14, 18, 20, 36, 38	
199.090			892
199.100			936, 938
199.110			938, 956
199.160			30, 904

elring		Das Original	
199.180			875, 879, 881, 883
199.191		15, 17, 19, 21, 23, 25, 27, 29, 31, 33, 35, 37, 39, 41, 43, 607, 609, 639, 641, 643, 645, 647, 649, 875, 883, 885, 887, 893, 903, 905, 907, 909, 911, 913, 915, 917, 919, 921, 925, 927, 937, 939, 953, 955, 957	
199.220			783, 785, 959, 963, 965, 967
199.230			783, 785, 959, 963, 965, 967
199.440		417, 419, 429, 445, 447, 449, 541, 543, 545, 547, 549, 551, 553, 559, 561	
200.941			42, 656, 1142
206.954		995, 999, 1007, 1029, 1043, 1097, 1099, 1149	
207.210			23, 603, 895
211.770			1138, 1140
212.410		210, 212, 214, 232, 234, 236, 238, 370	
212.440			232, 234, 236, 238
212.610		604, 606, 610, 612, 614, 616, 618	
214.171			79
214.390			198, 200
214.540		1037, 1039, 1079, 1081, 1093, 1095	
214.600			75
214.680			417, 427, 429
214.700			1056, 1058, 1060, 1062
214.711		1056, 1058, 1060, 1062, 1064, 1066, 1070, 1072, 1074	
214.800			431, 445
215.000			328, 340, 342, 352, 382
215.190			417, 427, 429
215.451			695, 715, 717
215.570			328
215.580			328
215.660		208, 226, 228, 230, 232, 244, 246, 248, 254, 256, 258	
215.970		226, 228, 230, 232, 244, 254, 256, 258	
216.470			752, 772, 774, 930, 944
216.500			725, 747, 929
216.730			589, 597, 605, 611, 615
217.001		22, 24, 28, 30, 904, 906, 908, 910, 912, 914, 916, 918, 920	
217.021		22, 24, 28, 30, 904, 906, 908, 910, 912, 914, 916, 918, 920	
217.031		22, 24, 28, 30, 904, 906, 908, 910, 912, 914, 916, 918, 920	
217.052		24, 26, 28, 30, 910, 912, 914, 916, 918	
217.484			1028, 1096, 1098
217.510			1146
217.580			542, 546, 548, 550, 552
217.590			498
218.841			694
218.850			694, 696, 718
218.890			718
218.970			764
219.071			764, 766, 938
219.100			766, 938
219.170			764, 938
219.230			732, 896
219.410			798
219.570			78
219.580			78

elring		Das Original	
219.590			78
219.691			804
219.721			804
219.861			804
219.960			511
220.190			152, 154
220.750			79
220.780			570
221.290			1008, 1010
221.490			1144
222.800			795
222.810			795
223.440		73, 75, 77, 81, 361, 369	
223.890		224, 266, 268, 314, 316, 318, 320, 324, 374, 378, 380, 382	
224.460			1146
225.060		299, 303, 305, 307, 311, 313	
225.150			1147
225.170		315, 319, 341, 345, 347, 379, 385	
226.220			1128
226.400			1018, 1028, 1034
226.510			153
226.600			730
227.951		298, 302, 304, 306, 312	
227.961		298, 302, 304, 306, 312	
227.971		298, 302, 304, 306, 312	
227.981		298, 302, 304, 306, 312	
227.991		298, 302, 304, 306, 312	
228.001		298, 302, 304, 306, 312	
228.400			70
228.470			70
228.512		742, 744, 770, 1104	
228.522		742, 744, 770, 1104	
228.532		742, 744, 770, 1104	
228.542		742, 744, 770, 1104	
228.680			431, 445
228.690		489, 497, 509, 511, 513	
229.302			327
230.521			216, 218
231.240		221, 223, 225, 327, 329, 373	
232.480			721
232.830			97
232.860			415, 457, 459
232.910		217, 225, 265, 267, 321, 323, 325, 373, 375, 377, 379, 383	
233.220			326
233.250			327
233.370		420, 436, 438, 440, 442, 448, 450, 452, 454	
233.380			504, 506, 514, 516, 518
233.740			1146
234.640			510, 512
235.381			216, 218
235.421			216, 218
235.610		73, 75, 93, 95, 97, 99, 101, 123, 125, 127, 149, 151, 153, 155, 157, 159, 161, 163, 165, 167, 169, 171, 185, 187, 189, 191, 195, 327, 329, 331, 333, 335, 337, 339, 341, 343, 345, 347, 349, 351, 365, 367, 369, 385, 649	

elring Das Original	
235.620	101, 103, 105, 107, 109, 111, 113, 115, 117, 185, 219, 329, 341, 343, 353, 361, 363, 383
	217, 221, 223, 225, 241, 243, 265, 267, 269, 271, 273, 275, 277, 279, 281, 283, 285, 287, 289, 291, 293, 295, 297, 299, 301, 303, 305, 307, 309, 313, 315, 317, 319, 321, 323, 325, 327, 355, 373, 375, 377, 379, 381, 383, 1147
235.650	
235.900	94, 96, 154, 156, 158
236.040	94, 96, 154, 156, 158
236.170	94, 96
236.280	490, 520, 522
236.320	155, 157, 159
236.340	154, 158
236.660	71
236.760	72
237.833	862
238.708	415, 417, 423, 425, 427, 429, 431, 433, 435, 437, 471, 473, 475, 477, 479, 485, 487, 493, 495, 497, 499, 503, 527, 531, 533, 535, 537, 541, 563, 565
240.050	73
240.160	332, 334
240.170	332, 334
240.810	714, 716
240.820	716
242.390	218
242.620	69, 71, 73, 75, 77, 361
242.650	69, 71, 73, 75, 77, 81, 361
243.205	115, 219, 221, 223, 225, 267, 269, 311, 319, 321, 335, 353, 363, 373, 381, 881
243.970	588
244.441	95, 97
244.650	320, 322, 382
244.710	216, 264, 320, 322, 372, 376, 382
244.891	122, 124, 186, 188, 364, 366
245.620	300, 308
245.630	300, 308
245.640	300, 308
245.650	300, 308
245.660	300, 308
245.670	300, 308
245.690	324, 382
246.090	1136, 1138, 1144, 1150
246.100	1136, 1138, 1144, 1150
246.150	153, 155
246.680	72, 74
247.120	241, 269, 271, 273, 275
247.270	844
247.280	957
247.290	843, 863
247.405	549, 551
248.097	73, 83, 85, 87, 93, 119, 121, 127, 129, 177, 179, 181, 183
248.260	326
248.270	69, 71, 73, 75, 77, 81, 361
248.300	123, 125, 127, 187, 189, 191, 193, 195, 197, 199, 365, 367, 369
249.200	546, 548, 550
249.210	542, 546, 548, 550, 552

elring Das Original	
249.570	216, 372
249.750	420, 452, 454
250.007	475, 535
252.740	168, 172
252.750	168, 172
252.760	168, 172
252.960	166, 168, 172, 174, 176
252.970	166, 168, 172, 174, 176
252.980	166, 168, 172, 174, 176
255.040	1008, 1010
255.050	1030, 1032
255.060	1082
255.070	1110, 1112, 1128
255.130	514, 516, 518
255.570	328, 352
257.360	502, 532
257.400	417, 419, 421, 429, 445, 447, 449, 459, 491, 493, 499, 501, 519, 521, 523, 525
257.770	417, 419, 421, 429, 445, 447, 449, 459
257.910	22, 40, 612, 616, 618, 620, 946
258.270	794, 796
258.311	687, 697, 719, 865
258.620	687, 695, 697, 865
258.760	726, 764, 940
258.780	715, 717
258.850	794
258.920	664
259.821	592, 594
259.930	453
259.972	527
260.320	889
261.160	123, 187, 367
261.190	185, 365
261.330	699, 701, 707, 709, 713, 877, 1015, 1017, 1019, 1021, 1027
261.420	716
262.500	155
262.650	703, 711, 877, 1025
262.790	750, 756, 758, 760
262.820	724, 746, 760, 928
262.980	794, 796
263.380	799, 801, 803, 805
263.600	241, 243, 267, 269, 271, 273, 275, 277, 279, 281, 283, 285, 287, 289, 291, 293, 295, 297, 299, 301, 303, 305, 307, 309, 311, 313, 319, 321, 331, 333, 335, 337, 349, 375, 381
263.620	510
264.730	100, 102, 104, 106, 108, 110, 114, 360
265.371	1106, 1108, 1110, 1122
265.381	1106, 1108, 1110, 1122
265.391	1106, 1108, 1110, 1122
265.421	1132
265.441	1132
265.481	1132
266.060	144, 146, 148, 150, 1086, 1088, 1090
266.250	527, 539, 541, 555, 557, 559
267.000	652
267.460	328, 348, 350

elring Das Original	
267.551	742, 744, 746, 748, 750, 752, 754, 756, 758, 760, 770, 772, 774, 928, 930, 932, 934, 936, 944, 1102, 1104, 1120
267.701	1079, 1093
267.830	428
267.840	415, 417, 425, 427, 429
268.041	554, 556
268.050	554, 556
268.160	554, 556
268.170	554, 556
268.180	554, 556
268.190	554, 556
268.340	444
268.350	444
268.360	444
270.190	490, 492, 518, 520, 522, 524
271.160	724
271.210	798, 804
272.091	511, 513
272.110	510
272.520	541, 545, 559, 561
274.410	9, 11, 585, 589, 593, 601, 603, 637, 857, 859, 861, 883
275.150	70
278.930	340, 342, 382
278.940	340, 342, 382
279.422	622, 624, 626
279.532	622, 624, 626
279.542	622, 624, 626
279.810	219
280.350	777, 947, 1107, 1109, 1111, 1133
283.561	504
283.571	504
283.581	504
284.300	324, 382
284.460	547, 549, 551, 553
284.470	546, 548
284.540	324
284.680	699, 709, 1017, 1019, 1021, 1027
284.890	264, 266, 376, 378
285.023	82, 84
285.040	82, 84
286.600	783, 965
287.300	1137, 1139, 1145, 1151
287.500	1078, 1080
287.560	1030, 1032
287.630	1008, 1010
287.777	1148
287.785	1148
290.440	184
290.710	11, 13, 15, 21, 637, 639, 843, 845, 849, 853, 865, 867, 869, 871, 873, 1001
290.790	31, 905, 909
290.821	889
290.910	783, 785, 957, 959, 963, 965, 967
290.930	685, 815
291.530	815

 Das Original	
291.540	685, 815
292.011	104, 106, 110, 112, 114, 116, 362
293.250	430
293.810	502
293.946	957
294.110	23, 25, 29, 31, 33, 41, 43, 651, 693, 713, 715, 727, 729, 731, 733, 735, 737, 739, 741, 763, 765, 767, 769, 803, 805, 837, 845, 863, 875, 879, 881, 891, 895, 897, 899, 901, 903, 905, 907, 909, 911, 913, 915, 917, 919, 921, 923, 939, 941, 943, 953
294.250	23, 25, 29, 31, 33, 651, 693, 713, 715, 727, 729, 731, 733, 735, 737, 739, 741, 763, 765, 767, 803, 805, 845, 863, 875, 879, 881, 891, 895, 897, 899, 901, 903, 905, 907, 909, 911, 913, 915, 917, 919, 921, 923, 939, 941
294.357	149, 199, 201, 203, 205, 207, 209, 211, 213, 215, 217, 219, 227, 229, 231, 233, 235, 237, 239, 245, 247, 249, 251, 253, 255, 257, 259, 261, 263, 329, 349, 351, 371, 1147
295.500	220, 222, 224, 372
295.750	418, 720, 722, 724
295.751	418, 720, 722, 724
295.780	122, 124
295.930	698, 722
297.580	95, 97
297.590	125, 127, 189, 191, 193, 195, 197, 369
298.130	491, 501, 521, 523, 525
298.220	418, 722
298.247	43, 45, 657, 663, 1143, 1145
298.400	326
298.480	651, 653, 655, 659, 665, 667, 843, 863, 953, 969
298.551	526
298.670	623, 625, 627, 661
298.770	623, 625, 627, 655, 659, 661
298.900	499
299.401	8, 636, 836, 838, 840
299.510	549, 551
299.670	71
299.681	71
299.720	280, 282, 286, 288, 290, 292, 294, 296
299.770	500
299.780	280, 282, 286, 288, 290, 292, 294, 296
299.790	280, 282, 286, 288, 290, 292, 294, 296
299.800	280, 282, 286, 288, 290, 292, 294, 296
299.810	280, 282, 286, 288, 290, 292, 294, 296
299.820	280, 282, 286, 288, 290, 292, 294, 296
301.400	488, 496
301.870	415, 417, 421, 423, 425, 427, 429, 431, 433, 435, 437, 471, 473, 475, 477, 479, 481, 483, 485, 487, 489, 493, 495, 497, 499, 503, 531, 533, 535, 537
301.890	445, 489, 497, 509, 511, 513
302.170	623, 625, 627, 661
302.180	430
302.310	418
302.320	432, 476
302.340	432, 434, 476, 478, 480, 494, 502, 530
302.350	434, 480, 484, 494, 530

 Das Original	
302.530	623, 625, 627, 661
302.570	1145
302.589	661, 729, 731, 733, 735, 737, 739, 741, 769, 897, 899, 901, 903, 943, 957, 961
302.890	69, 71, 73, 75, 77, 81, 361
303.100	155
303.171	549
303.180	549, 551
303.951	72
304.000	612, 616
305.410	623, 625, 661
305.430	148, 150, 152, 648
305.890	233, 235, 237, 239
305.900	70
306.081	660
306.130	152, 154
306.350	415, 457, 459
306.620	586
307.611	148
308.180	606
308.190	606
308.200	606
308.210	20
308.590	68, 70
308.610	69, 71, 73, 75, 77, 81, 361
308.630	411, 413, 415, 419, 457, 459, 461, 463, 465, 467, 469
308.970	411, 413, 415, 419, 457, 459, 461, 463, 465, 467, 469
309.000	650
309.311	804
309.320	802
309.330	330, 332
309.340	330, 332
309.350	330, 332
309.361	330, 332
309.371	330, 332
309.381	330, 332
309.980	663
309.990	10, 12, 14, 638, 842, 852, 864, 866, 870
310.220	798
311.022	331, 333
311.040	74, 360
311.140	280, 282, 284, 286, 288, 290, 292, 294, 296, 300, 308
311.160	280, 282, 284, 286, 288, 290, 292, 294, 296, 300, 308
311.190	327
311.330	281, 283, 287, 289, 291, 293, 295, 297
313.201	124, 126, 188, 194
313.661	70
314.350	664, 666
314.430	664, 666
314.491	586, 592
314.773	72, 82, 84, 86, 92, 118, 120, 126, 176, 178, 180, 182
315.260	1033
315.494	685, 687, 693, 695, 697, 705, 719, 865

 Das Original	
317.020	995, 997, 999, 1017, 1033
318.170	1032
318.550	432, 434, 476, 478, 480, 494, 502, 530
318.580	434, 480, 484, 494, 530
318.590	434, 470, 480, 484, 486, 494, 498
318.600	470, 486, 498
318.610	526, 538, 540, 554, 556
318.620	526, 538, 540, 554, 556
318.630	538, 554, 556, 558
318.640	538, 554, 556, 558
318.730	326
318.968	1005, 1013, 1015, 1041, 1043, 1045
318.974	1005, 1013, 1041, 1043, 1045
319.470	882
319.550	882
322.980	68
323.300	122, 124, 126, 186, 188, 190, 192, 194, 196, 364, 366, 368
323.330	314, 316, 318, 378
323.370	314, 316, 318, 378
323.480	280, 282, 284, 286, 288, 290, 292, 294, 296, 298, 300, 302, 304, 306, 308, 312, 332
323.520	280, 282, 286, 288, 290, 292, 294, 296
325.040	216, 264, 266, 314, 320, 322, 324, 372, 376, 378, 382
325.121	1004, 1042, 1044
325.155	43, 45, 73, 83, 85, 87, 89, 91, 93, 101, 103, 105, 107, 109, 111, 113, 115, 119, 121, 127, 129, 131, 133, 135, 137, 139, 141, 143, 145, 149, 177, 179, 181, 183, 185, 199, 201, 203, 205, 207, 209, 211, 213, 215, 217, 219, 221, 223, 225, 227, 229, 231, 233, 235, 237, 239, 241, 243, 245, 247, 249, 251, 253, 255, 257, 259, 261, 263, 265, 269, 271, 273, 275, 277, 279, 329, 349, 351, 353, 361, 363, 371, 373, 375, 377, 1085, 1087, 1091
325.449	1148
325.930	122, 124, 184, 186, 188, 364, 366
326.100	431
326.250	435, 437, 471, 481, 483, 485, 487, 495, 497, 499
326.470	211, 213, 215, 233, 235, 237, 239, 261, 263, 265, 329, 337, 339, 377
326.560	434, 470, 480, 484, 486, 494, 498
328.170	157, 161
328.180	157
328.572	661
329.606	423, 437, 471
330.060	778
330.200	98, 100, 158, 160, 162, 164, 166, 168, 170
330.340	144, 146, 148, 150, 1086, 1088, 1090
330.370	656, 658
330.390	698, 700, 702, 704, 706, 708, 710, 712, 876, 1014, 1016, 1018, 1020, 1022, 1024, 1026
330.736	605, 607, 611, 613, 615, 617, 619
330.971	702, 704, 1022
330.981	702, 704, 1022
330.991	702, 704, 1022
331.001	702, 704, 1022
331.011	702, 704, 1022



331.230	41, 955
331.330	219, 281, 283, 285, 287, 289, 291, 293, 295, 297, 299, 301, 303, 305, 307, 309, 311, 313, 315, 331, 333, 339
331.530	843, 863
331.540	724, 746, 778, 928
331.550	724, 746, 778, 928
331.600	746, 928
331.640	719
331.690	717
331.740	764, 940
331.781	799, 805
331.810	719
331.970	779
332.130	838, 840
332.210	881, 883
332.230	686
332.280	799, 801
332.330	21, 25, 27, 29, 31, 41, 911, 913, 915, 917, 919, 955
332.380	153
332.470	25, 27, 29, 31, 911, 913, 915, 917, 919
332.500	800
332.670	715, 761, 779
332.691	948
332.800	90
332.830	324
333.150	513
334.670	11, 13, 15, 637, 639, 867, 871, 873
334.690	10, 12, 866
335.300	720
335.600	660
336.999	1145
338.720	1092, 1094
338.730	1092, 1094
338.820	1078, 1080, 1092, 1094
338.870	685, 815
339.250	660
339.260	11, 15, 639, 843, 853, 865, 867, 869, 871, 873
339.280	781, 787
339.380	280, 282, 284, 286, 290, 292, 294
339.490	725, 745
339.550	803
339.580	15, 17, 19, 21, 23, 25, 27, 29, 31, 33, 35, 37, 39, 41, 43, 639, 641, 643, 645, 647, 649, 883, 885, 887, 893, 903, 905, 907, 909, 911, 913, 915, 917, 919, 921, 925, 927, 937, 939, 953, 955, 957
339.601	240, 242, 268, 270, 272, 274, 276, 278, 374
339.610	88, 90
339.650	490, 518, 520, 522
340.230	1137, 1139, 1145, 1151
340.260	786, 788, 966, 968
340.280	99, 101, 159, 161, 163, 165, 167, 169, 171
340.290	99, 101, 159, 161, 163, 165, 167, 169, 171
340.470	17, 33, 35, 37, 607, 609, 639, 641, 643, 645, 647, 649, 883, 885, 887, 925, 927
340.590	314, 316, 318, 378



341.000	280, 282, 284, 286, 288, 290, 292, 296
341.080	699, 707, 709, 713, 877, 1017, 1019, 1021, 1027
341.400	340, 342, 344, 346, 348, 384
341.410	352
342.093	73, 83, 85, 87, 89, 93, 101, 103, 113, 119, 121, 127, 129, 131, 133, 139, 149, 177, 179, 181, 183, 185, 199, 201, 203, 205, 207, 209, 211, 215, 217, 219, 227, 229, 231, 233, 245, 247, 249, 251, 253, 255, 257, 259, 263, 361, 371, 1085, 1087, 1147
344.661	10, 14, 638, 852, 864, 866, 868, 870, 872
344.671	10, 12, 14, 636, 638, 866, 868, 870, 872
344.720	11, 13, 867
344.771	21
346.510	1033
346.520	1032
351.260	786, 788, 966, 968
351.270	787, 789, 967, 969
351.900	98, 100, 158, 160, 162, 164, 166, 168, 170
352.421	74, 76
352.810	99, 101, 159, 161, 163, 169, 171
353.090	787, 789, 967, 969
353.264	418, 444, 446, 448
353.273	420
353.292	418, 444, 446, 448
353.301	420
353.540	532
353.770	694
353.780	787, 789, 967, 969
353.830	22, 602, 894
353.840	23, 593, 601, 603, 895
353.990	23, 593, 601, 603, 895
354.010	22, 602, 894
354.030	22, 592, 600, 602, 894
354.070	866
354.562	354
354.571	354
354.721	543
354.802	721, 723, 725
355.340	23, 593, 601, 603, 895
355.792	1098, 1100
356.180	40, 954
356.390	590, 594, 598, 600
357.900	444
359.160	434, 436, 470, 480, 482, 484, 486, 494, 496, 498
359.180	541, 545, 559, 561
359.220	541, 545, 559, 561
359.260	541, 543, 545, 547, 549, 553, 559, 561
359.300	17, 29, 31, 33, 35, 37, 607, 609, 639, 641, 643, 645, 647, 649, 883, 885, 887, 917, 919, 925, 927
359.370	417, 429
359.590	557, 559
360.130	842
360.140	862
361.023	557, 559
361.473	480, 482, 484, 486, 494, 496, 498



361.503	480, 482, 484, 486, 494, 496, 498
362.141	1007, 1009
362.691	665
362.730	1145
362.740	1145
362.832	1018, 1028, 1034
363.190	428
364.071	1039, 1079, 1081, 1093, 1095
364.381	1036, 1038, 1078, 1080, 1092, 1094
364.500	491, 493, 499, 501, 519, 521, 523, 525, 527, 529
364.525	414, 456, 458
364.700	95, 97, 153, 155, 157, 159
364.710	93
364.900	623, 625, 627
364.950	623, 625, 627
365.020	15, 19, 21, 37, 39
365.030	725, 745
365.060	889
366.070	416, 426
366.090	416
366.500	435, 437, 471, 481, 483, 485, 487, 495, 497, 499
366.530	470, 486, 498
366.560	434, 436, 480, 482, 484, 494, 496
366.670	100, 102, 104, 106, 108, 110, 112, 114, 116, 360, 362
366.940	603
367.050	602
367.480	491, 521, 523
369.460	514, 516, 518
369.470	419, 685, 687, 693, 695, 697, 699, 703, 705, 715, 717, 719, 721, 723, 725, 865, 1023
369.530	685, 687, 693, 695, 697, 705, 715, 717, 719, 865
369.710	543, 547, 549
369.720	543, 547, 549
369.733	543, 547, 549, 551, 553
369.760	543, 547, 551, 553
369.890	1145
372.500	18, 20
372.940	662
373.100	540, 544, 558, 560
373.160	417, 429
373.180	434, 436, 470
373.281	798, 800
373.380	514, 516, 518
373.450	15, 19
373.490	1143
373.580	609
373.960	218
374.000	98, 100, 160, 162, 164, 168, 170
374.180	782, 784, 962, 964, 966
374.230	640
374.240	8, 10, 584, 586, 636, 690, 854, 856, 858, 860, 1004
374.590	1037, 1039, 1079, 1081, 1093, 1095, 1111, 1131

elring Das Original	
374.650	696
374.680	781, 787, 1037, 1039, 1079, 1081, 1093, 1095, 1131
374.710	416, 428
374.880	652
374.891	652
374.940	699, 707, 709, 713, 877
374.990	1130
375.000	778
375.060	36
375.070	15, 637, 841, 843, 845, 847, 849, 851, 853, 865, 867, 869, 1001
375.080	42, 44
375.090	902
375.100	696
375.120	847
375.140	893
375.160	837, 841, 843, 847
375.170	952
375.190	874
375.200	718
375.230	915
375.270	42, 44
375.290	881, 883
375.300	718
375.310	914
375.320	11, 13, 15, 637, 639, 843, 853, 865, 867, 869, 871, 873
375.340	40, 954
375.430	798
375.470	779, 949, 951, 953
375.490	853
375.510	702, 710, 876, 1024
375.540	128, 130, 132, 138, 144, 1084, 1086, 1090
375.550	656
375.560	1139, 1141
375.600	1131
375.640	720, 722, 724
376.121	90
376.131	90
376.330	720, 722, 724
376.340	721, 723, 725
376.350	455
376.400	656, 658
376.500	420, 452, 454
376.590	452, 454
376.672	1122
376.730	95
376.843	184, 186, 364
377.160	1036, 1038, 1078, 1080, 1092, 1094
377.170	1011, 1031, 1035
377.290	526, 528
377.450	79
377.811	1003, 1009, 1011, 1013, 1019, 1029, 1031, 1033, 1035
378.140	538, 554, 556
380.150	94, 96, 98, 100, 152, 154, 156, 158, 160, 162, 164, 166, 168, 170

elring Das Original	
380.271	507
380.290	696
380.440	94, 96, 154, 156, 158
380.960	799, 801
381.130	627
381.150	656
381.640	71, 73, 75
382.130	22, 40, 612, 946
382.440	798
382.711	428, 444, 446, 448
382.750	470, 486, 498
382.800	470, 486, 498
383.230	998
383.280	144, 146, 148, 1086, 1088, 1090
383.290	70
383.300	70
383.320	70
383.890	506
383.900	506
383.910	506
384.420	714, 716
384.561	584
384.640	951, 953
384.680	720
386.430	721
387.500	156
387.580	22, 24, 26, 28, 30, 904, 906, 908, 910, 912, 914, 916
387.662	653
388.151	685, 687, 693, 695, 697, 719
388.160	1039, 1079, 1081, 1093, 1095
388.170	184
388.190	1130
388.200	882
388.210	882
388.260	1111
388.390	570
388.620	798, 800
388.724	507, 519
388.780	161
388.930	148, 648
388.940	1005, 1013, 1015, 1041, 1043, 1045
388.961	1008
388.970	1010
388.981	1010
389.000	1008
389.010	1010
389.021	1010
389.041	703, 711, 877, 1025
389.050	1030, 1032
389.060	1036, 1038, 1078, 1080, 1092, 1094
389.070	1036, 1038, 1078, 1080, 1094
389.080	1106, 1108, 1110, 1122, 1132
389.110	1000, 1002, 1008, 1010, 1030, 1034
389.121	703, 711, 877, 1025
389.140	776, 946, 1106, 1108, 1110, 1122, 1124, 1132

elring Das Original	
389.161	1130
389.280	816
389.420	220, 222, 224, 372
389.430	778, 948, 950, 952
389.440	778, 948, 950, 952
389.450	778, 948, 950, 952
389.700	414, 456, 458
389.980	1032
390.440	698, 722
390.600	786, 788, 968
390.801	334
390.811	334
391.000	160
392.440	777, 947, 1127, 1133
393.990	743, 745, 747, 749, 771, 773, 929, 931, 933, 945, 1103, 1105, 1121
394.012	743, 745, 747, 749, 771, 773, 929, 931, 933, 945, 1103, 1105, 1121
394.030	661, 731
394.290	1103
394.320	1145
397.130	869
397.150	68, 70
397.230	240, 242, 268, 270, 272, 274, 276, 278, 374
397.341	868
397.470	8, 636, 690, 856, 858, 860
398.260	125, 127, 189, 193, 195
398.450	1001, 1003, 1009, 1011, 1013, 1019, 1029, 1031, 1033, 1035
399.570	844, 846, 850, 852
399.630	840, 844, 862
399.840	696, 864
399.870	16, 638, 882, 884, 886
401.820	1146
403.730	421, 427, 429, 433, 435, 437, 471, 477, 479, 481, 483, 485, 487, 489, 495, 497, 499, 503, 527, 531, 533, 539, 541, 555, 557, 559, 563, 603, 605, 607, 611, 613, 615, 617, 619, 623, 625, 627, 653, 661, 663, 665, 715, 717, 719, 751, 757, 759, 761, 763, 785, 787, 799, 801, 889, 967, 969
403.741	208, 226, 228, 230, 232, 244, 246, 248, 254, 256, 258
405.990	1005, 1013, 1015, 1041, 1043, 1045, 1077
406.040	208, 226, 228, 230, 232, 244, 246, 248, 254, 256, 258
406.490	1047, 1049, 1051, 1053, 1055, 1057, 1059, 1061, 1063, 1065, 1067, 1077
407.330	532
408.000	532
410.050	605, 607, 611, 613, 615, 617, 619
412.872	128, 130, 132, 138, 144, 1084, 1086, 1090
412.882	128, 130, 132, 138, 144, 1084, 1086, 1090
412.912	128, 130, 132, 138, 144, 1084, 1086, 1090
413.470	653
413.690	128, 130
413.820	250, 252, 258, 260, 262
413.830	210, 212, 214, 232, 234, 236, 238, 250, 252, 258, 260, 262, 264, 370, 376



413.860	210, 212, 214, 232, 234, 236, 238, 250, 252, 258, 260, 262, 264, 370, 376
413.900	211, 213, 215, 251, 253, 259, 261, 263, 265, 313, 371, 377, 379
415.690	762
416.100	219
416.300	219
418.130	42, 656
419.530	839, 841
419.700	957, 959, 961
419.730	783, 785, 955, 957, 959, 961, 963, 965, 967
420.451	729, 731, 735, 737, 901, 903
420.730	651
421.120	650
421.432	803, 805
422.090	1057, 1059, 1061, 1063, 1065, 1067, 1069, 1071, 1073, 1075, 1139, 1141
422.370	416, 426, 428
422.511	738, 740, 898
422.531	768, 942
422.551	768, 942
422.880	221, 223, 373
422.890	221, 223, 225, 373
423.610	426
423.670	426
423.980	416, 426
424.040	1056, 1060, 1068, 1070
424.050	1056, 1060, 1068, 1070
424.070	1056, 1060, 1068, 1070
424.081	1058, 1062, 1064, 1066, 1072, 1074
424.091	1058, 1062, 1064, 1066, 1072, 1074
424.101	1058, 1062, 1064, 1066, 1072, 1074
424.420	488
424.480	488
424.510	433, 435, 437, 471, 477, 479, 481, 483, 485, 487, 495, 497, 499, 503, 531, 533
424.560	1000, 1006, 1008
424.770	432, 476, 478, 502
424.780	79, 489
424.800	427, 429, 527, 539, 541, 555, 557, 559, 563, 603, 605, 607, 611, 613, 615, 617, 619, 623, 625, 627, 653, 661, 715, 717, 719, 763, 889
424.820	433, 435, 437, 471, 477, 479, 481, 483, 485, 487, 495, 497, 499, 503, 531, 533, 663, 665, 785, 787, 967, 969
424.841	653, 657, 659, 663, 665, 969
424.870	421, 489
424.901	434, 436, 480, 482, 484, 494, 496
424.930	1028, 1042, 1096, 1098
425.140	420
425.150	420
425.170	420
425.290	421
425.370	434, 480, 484, 494, 530
425.390	436, 470, 482, 484, 486, 494, 498, 530
426.830	418, 698, 720, 722, 724
426.850	771
426.890	414, 456, 458



427.130	281, 283, 285, 287, 289, 291, 293, 295, 297, 301, 309
427.910	846
428.210	651, 653, 763, 779, 953
428.440	508, 512
428.450	508, 512
428.460	508, 512
428.640	512
428.680	511, 513
428.690	510, 512
428.750	946
428.770	810
428.780	810
428.880	144, 1086, 1088, 1090
428.900	1131
428.910	1046, 1048, 1050, 1052, 1054, 1056, 1058, 1064, 1074, 1076
428.960	700, 701, 1014, 1015
428.970	9, 11, 585, 587, 637, 691, 855, 857, 859, 861, 1005
429.000	783, 785, 959, 963, 965, 967
429.040	703, 711, 877, 1025
429.090	95
429.170	776, 946
429.320	643, 651, 653, 655, 763, 779, 953
429.910	224, 264, 266, 314, 316, 318, 324, 374, 376, 378, 380, 382
429.980	224, 264, 266, 314, 316, 318, 324, 374, 376, 378, 380, 382
430.140	777, 947
430.160	699, 707, 709, 877, 1017, 1019, 1021, 1027
430.181	312, 378
430.190	147, 149, 151, 153, 649
430.400	22, 24, 28, 30, 904, 906, 908, 910, 912, 914, 916, 918, 920
430.830	716
430.840	716
430.920	188
431.110	779, 949, 951
431.120	779, 949, 951, 953
431.180	587, 691, 855, 857, 1005
431.250	18, 20, 36, 38, 892
431.310	9, 11, 585, 587, 637, 691, 855, 857, 859, 861, 1005
431.321	774
431.331	774
431.341	774
431.351	774
431.381	694
431.390	875
431.401	586, 690, 854, 856, 1004
431.420	799, 801
431.440	714, 716, 718
431.450	694
431.460	694
431.470	850, 852
431.500	948
431.551	798, 804



431.560	14, 636, 844, 848, 850, 852, 866, 868, 1000
431.590	638, 864, 870
431.610	716
431.620	948
432.894	653
432.924	657, 659
433.113	657
433.250	211, 213, 215, 233, 235, 237, 239, 251, 253, 259, 261, 263, 265, 313, 371, 377, 379
433.301	233, 235, 237, 239
434.300	1030, 1034
434.310	23, 905, 909, 911, 915
434.320	1030
434.330	800
434.350	23, 603, 895
434.420	25, 27, 31, 905, 907, 909, 911, 913, 917
434.500	17, 25, 27, 29, 31, 33, 35, 37, 41, 607, 609, 639, 641, 643, 645, 647, 649, 883, 885, 887, 911, 913, 915, 917, 919, 925, 927, 955
434.510	1078
434.550	883
434.840	762, 778
434.941	687, 695, 697, 715, 717, 719, 785, 787, 795, 799, 801, 803, 805, 865, 889
435.361	714, 862, 874, 878, 880
435.372	715, 875, 879, 881
435.410	715, 875, 879, 881
435.510	837
435.810	43, 45, 657, 663, 1143, 1145
435.830	43, 45, 657, 663, 1143, 1145
436.010	432, 436, 470, 476, 478, 482, 484, 486, 496, 498, 502, 530, 532, 538, 554, 556, 558
436.521	762
436.530	762, 766
436.540	762, 764, 766, 938, 940
436.550	768
436.570	768
436.581	768, 942
436.651	712, 714, 726, 734, 894
436.690	734
437.370	776, 946, 1122, 1124, 1126
438.710	429, 445, 447
438.820	417, 419, 447, 449
439.000	25, 27, 29, 31, 911, 913, 915, 917, 919
439.041	220, 222, 224, 372
439.101	1039, 1081
439.760	769, 943
439.770	769, 943
440.290	778
440.710	841, 843, 845, 847, 851, 853
440.720	591, 597, 599, 837, 841, 843, 845, 847
440.730	33, 891, 921, 923
440.750	33, 715, 841, 845, 863, 875, 879, 881, 883, 891, 921, 923
440.760	715, 841, 845, 863, 875, 879, 881, 883
440.780	715, 837, 839, 841, 863, 875, 879, 881
440.810	841, 843, 845
440.830	33, 37, 39, 891, 921, 923

elring Das Original	
441.170	613, 615, 617, 619, 621, 623
441.310	332, 334
442.050	564
442.180	564
442.802	746, 928, 1104
442.812	746, 928, 1104
442.822	746, 928, 1104
442.832	746, 928, 1104
444.100	582
444.310	414, 424
444.320	416, 426
444.330	416, 426
444.360	476
444.370	476, 478
444.440	480, 482, 484, 494, 496
444.450	474, 492
444.460	534, 536
444.570	1131
444.760	15, 637, 845, 853, 867, 869, 1001
444.930	408
444.970	418, 462, 466, 468
445.060	9, 11, 585, 587, 637, 691, 855, 857, 859, 861, 1005
445.100	9, 11, 585, 587, 637, 691, 855, 857, 859, 861, 1005
445.130	417, 419, 429, 445, 447, 449
445.240	421
445.250	420
445.300	476, 478
445.400	488
445.450	434, 436
445.460	434, 436
445.470	480, 482, 484, 494, 496
445.520	432
445.680	20
445.890	68, 70
445.910	72, 74, 76, 80, 360
445.920	1006, 1008
446.111	44, 656, 1144
446.260	1110, 1130
446.340	1041
446.363	650
446.373	650
446.383	650
446.461	1039, 1079
446.481	1037, 1039, 1079, 1081, 1095
446.870	488
446.900	74, 360
446.920	86, 88, 178, 180, 182, 184
447.050	72, 82, 84, 86, 92, 118, 120, 126, 176, 178, 180, 182
447.122	802
447.132	802
447.160	1040
447.340	129, 131
447.472	220, 222, 224, 372
447.482	220, 222, 224, 372

elring Das Original	
447.492	220, 222, 224, 372
448.390	652, 952
448.400	80
448.440	652, 654, 952
448.510	15, 19, 21, 25, 27, 29, 31, 37, 39, 893, 911, 913, 915, 917, 919
448.520	416, 418
449.290	763, 779
449.390	94, 96
449.471	750, 754, 756, 758, 760, 774, 934, 936
449.590	706, 708, 876, 1026
449.600	772, 944, 1120
449.650	408
449.680	772, 774, 944
449.740	696, 864
451.260	811
451.680	546, 550
451.740	546, 550
451.750	546, 550
451.790	221
452.150	8, 586, 854, 856, 858, 1004
452.390	515
452.400	787, 789, 967, 969
452.640	778, 786, 788, 948, 950, 952, 968
452.660	788, 968
452.680	788, 968
452.700	778, 948, 950, 952
452.740	880
452.850	1114, 1116
452.990	98, 100, 158, 160, 162, 164, 166, 168, 170
453.060	763, 779
453.351	72
453.420	698, 706, 708, 712, 876, 1016, 1018, 1020, 1026
453.490	724, 744, 746
453.500	746, 928, 1104
453.750	743, 745, 747, 771, 773, 929, 945, 1105, 1121
453.800	739, 741, 899
453.820	78
454.020	598
455.150	78
455.220	653
455.230	721
455.270	720
455.740	409, 411, 413, 419, 421, 431, 437, 439, 441, 443, 445, 447, 449, 451, 453, 455, 457, 459, 461, 463, 465, 467, 469, 473, 475, 489, 491, 493, 497, 499, 501, 509, 511, 513, 515, 517, 519, 521, 523, 525, 527, 529
456.100	421, 449, 453
456.180	298, 302, 304
456.190	452
456.200	454
456.220	298, 302, 304
456.240	514
456.250	514, 516, 518
456.270	588
456.550	68

elring Das Original	
456.570	418
456.710	800
456.780	710, 876, 1024
456.840	771
457.160	720
457.200	72, 82, 84, 86, 92, 118, 120, 126, 176, 178, 180, 182
457.250	590, 594, 598, 600
457.430	419
457.531	1002
457.551	1008, 1010, 1012
457.812	606, 608
457.822	606, 608
457.832	606, 608
458.112	664, 666
458.200	1138
458.222	664, 666
458.330	418
458.340	446, 448
458.360	23, 25, 29, 31, 903, 905, 907, 909, 911, 913, 915, 917, 919, 921
458.370	70, 76, 78
458.380	416, 418
458.390	428, 444, 446
458.400	416, 418, 420, 428, 444, 446, 448, 458
458.441	1038
458.491	1078
458.521	1036
458.571	1080
458.591	1094
458.600	1036, 1038, 1078, 1080, 1094
458.620	685, 815, 817
458.660	1036, 1038, 1078, 1080, 1094
458.690	817
458.730	798, 804
458.790	817
458.810	724, 746, 760, 778, 928
458.821	73, 93
459.200	68
459.450	500
459.630	146, 150
459.760	762
459.860	1110
460.030	542, 562
460.600	1016
460.745	73, 87, 93, 119, 121, 179
460.970	1016
461.090	1017
461.100	1016
461.120	1017
461.380	106, 110, 112, 114, 116, 362
461.682	20, 70, 72, 74, 78, 92, 94, 96, 98, 100, 122, 124, 126, 148, 150, 152, 154, 156, 158, 160, 162, 164, 166, 168, 170, 172, 174, 176, 184, 186, 188, 190, 192, 194, 196, 198, 216, 218, 224, 264, 266, 268, 314, 316, 318, 320, 322, 324, 364, 366, 368, 372, 374, 376, 378, 380, 382, 648, 662, 664, 688, 690, 1144



462.713	714, 874, 878, 880
462.950	472, 474
464.050	643, 651, 653, 655, 953
464.200	1017
464.280	642, 650, 652, 654, 952
464.390	778, 948, 950, 952
464.450	796
464.560	796
464.590	797
464.630	796, 797
464.640	797
464.900	796
465.630	797
465.770	1016
467.593	610, 612, 614, 616, 618
467.762	209, 211, 215, 229, 231, 233, 237, 239, 247, 251, 259, 261, 263, 371, 377
467.830	1037, 1039, 1079, 1081, 1095
467.840	158
467.860	1037, 1039, 1079, 1081, 1093, 1095
467.880	1139, 1141
468.050	160
468.060	160, 162
468.210	158
468.410	1056, 1058, 1060, 1062, 1064, 1066, 1068, 1070, 1072, 1074
468.631	1057, 1059, 1061, 1063, 1065, 1067, 1069, 1071, 1073, 1075
468.690	1056, 1058, 1060, 1062, 1064, 1066, 1068, 1070, 1072, 1074
468.850	954
468.860	1094
468.870	954
468.920	954
468.930	954
469.070	770, 772, 944, 1120
469.080	771, 773, 945, 1121
469.350	731, 955
469.690	776, 946, 1122, 1124, 1126, 1150, 1152
469.830	506, 518
470.280	128, 130, 132, 138, 144, 1084, 1086, 1090
470.370	69, 71, 73, 75, 77, 81, 361
470.650	250, 252, 258, 260, 262, 264, 376
470.660	210, 212, 214, 370
471.060	795, 797, 803
471.100	326
471.110	326
471.120	326
471.130	326
471.140	326
471.150	326
471.240	797
471.650	80
471.740	590, 594, 598, 600
471.770	582
472.060	770
472.180	36



472.230	817
472.240	627
473.390	538, 554, 556, 558
473.480	816
473.491	70, 76, 78
473.500	685, 811, 815, 817, 819
473.650	341, 343, 345, 347, 349, 385
473.660	340, 342, 344, 346, 348, 382, 384
473.670	340, 342, 344, 346, 348, 382, 384
473.800	506
473.810	506
473.820	506
474.140	731, 955
475.030	881
475.480	662
475.490	662
475.920	88, 90
475.931	89, 91
475.961	91, 105, 107, 111, 113, 115, 135, 137, 141, 143, 149, 199, 201, 203, 205, 207, 209, 211, 213, 215, 217, 219, 221, 223, 225, 227, 229, 231, 233, 235, 237, 239, 245, 247, 249, 251, 253, 255, 257, 259, 261, 263, 329, 349, 351, 363, 371, 373, 1147
475.970	134, 136
475.980	134, 136
476.020	100, 102, 104, 106, 108, 110, 112, 114, 116, 360, 362
476.030	100, 102, 104, 106, 108, 110, 112, 114, 116, 360, 362
476.200	1038
476.213	1080
476.412	92
476.460	101, 107, 109, 111, 113, 115, 117, 363
476.551	1039, 1079, 1081, 1093, 1095
476.620	1152
476.691	15, 459, 543, 563, 585, 589, 591, 637, 845, 847, 851, 853, 865, 867, 869, 1001
476.750	23, 585, 589, 593, 601, 603, 883, 895
476.910	1138
476.920	1138
476.930	1138, 1140
476.981	1139, 1141
476.991	1139, 1141
477.010	15, 19, 21, 37, 39, 893, 937, 939, 957
477.260	731, 955
477.312	514, 516
477.322	514, 516
477.332	514, 516
477.390	602
477.630	149, 151, 153, 649
477.640	149, 151, 153, 155, 649
477.870	1144
477.970	994, 996, 998
478.650	191, 193, 195, 197, 199
478.660	75, 361
479.030	665
479.040	665



479.600	164
480.000	164
480.410	625, 627
480.650	837, 839
480.960	33, 891, 921, 923
480.980	32, 890, 920, 922
480.990	33, 891, 921, 923
481.300	783, 785, 955, 957, 959, 961, 963, 965, 967
481.320	783, 785, 955, 957, 959, 961, 963, 965, 967
481.340	219
481.450	583, 593, 595
481.900	888
481.940	412
482.140	98, 100, 158, 160, 162, 164, 166, 168, 170
482.230	337, 339
482.340	336, 338
482.350	336, 338
483.680	606
483.690	606
483.740	618, 620
483.770	617
483.780	616, 618, 620
484.730	547
484.750	684, 814
485.200	548
485.510	966, 968
485.910	640
485.960	641, 643, 885, 887, 895
486.000	816
486.040	641
486.060	640
486.070	640
486.470	1032
488.030	665, 667
490.001	698, 1016, 1018, 1020
490.011	698, 1016, 1018, 1020
490.021	698, 1016, 1018, 1020
490.031	698, 1016, 1018, 1020
490.041	698, 1016, 1018, 1020
490.240	73, 75
490.654	657, 659
490.921	148, 648
491.370	724
491.980	24, 26, 28, 30, 910, 912, 914, 916, 918
492.050	449, 451, 453, 455
492.060	409, 421, 437, 439, 441, 443, 449, 451, 453, 455, 505, 507, 515, 517, 519
492.160	448, 450, 452, 454
492.252	20
492.641	74
492.660	840
493.062	218
493.141	584, 588, 590
493.390	153
493.460	312, 378
493.870	218

elring Das Original	
493.940	613, 617, 619, 621
494.110	628
494.250	612
495.620	73, 83, 85, 87, 89, 93, 119, 121, 127, 129, 131, 133, 139, 145, 177, 179, 181, 183, 185, 1085, 1087, 1091
495.770	604, 606, 610, 612, 614, 616, 618
495.790	428
495.800	416, 426
495.840	428
495.850	428
495.900	431, 473, 475, 493
496.060	98
496.070	100
496.212	562
496.222	562
496.242	563
496.251	563
497.120	1114, 1116
497.150	580, 582, 584
497.230	101, 185, 361
497.240	184, 186, 364
497.360	695
497.380	684, 814
497.401	664
497.410	40, 954
497.420	664
497.490	664
497.740	89, 91
497.800	90
497.810	94
498.980	22, 24, 28, 30, 904, 906, 908, 910, 912, 914, 916, 918, 920
498.990	640
501.042	420
501.123	43, 45, 657, 663
502.990	184
503.400	689
503.721	421, 437, 439, 441, 443, 449, 451, 453, 455, 505, 515, 517, 519
503.754	779
503.791	500
503.950	192, 194
504.080	656
504.200	592, 600, 602
504.260	593, 601, 603
504.380	421, 445, 491, 493, 519, 521, 523, 525
504.483	651, 799, 803, 805
504.505	692
504.550	184
505.020	765, 939, 941
505.050	796
505.060	14, 636, 844, 850, 852, 866, 868, 1000
505.100	695, 697
505.120	718
505.180	760
505.210	718

elring Das Original	
505.250	694, 696
505.270	852
505.293	571
505.300	694
505.341	718
505.366	685, 687, 693, 695, 697, 705, 713, 715, 719, 725, 727, 735, 745, 747, 761, 763, 765, 767, 779, 865, 895, 929, 939, 941
505.371	718
505.391	718
505.450	779, 949, 951, 953
505.590	852
505.600	695
505.640	780
505.650	780
505.660	780
505.670	780
505.680	781, 787
505.690	781, 787
505.730	850, 852
505.740	685, 687, 693, 695, 697, 705, 717, 719, 865
505.838	15, 19, 21, 23, 25, 29, 31, 37, 39, 41, 43, 591, 595, 597, 599, 601, 799, 805, 837, 841, 843, 845, 847, 849, 851, 853, 865, 875, 893, 903, 905, 907, 909, 911, 913, 915, 917, 919, 921, 937, 939, 953, 957
506.550	17, 27, 29, 31, 33, 35, 37, 41, 607, 609, 639, 641, 643, 645, 647, 649, 883, 885, 887, 917, 919, 925, 927, 955
507.822	799, 803, 805
508.209	713, 715, 725, 727, 729, 731, 733, 735, 737, 739, 741, 745, 747, 751, 753, 755, 757, 759, 761, 763, 765, 767, 769, 773, 775, 779, 895, 897, 899, 901, 903, 929, 931, 935, 937, 939, 941, 943, 945, 1103
508.233	713, 715, 727, 729, 731, 733, 735, 737, 739, 741, 751, 753, 755, 757, 759, 761, 763, 765, 767, 769, 773, 775, 895, 897, 899, 901, 903, 931, 935, 937, 939, 941, 943, 945, 1103
508.462	803, 805
508.470	651, 803
508.544	803, 805
509.570	621
509.710	22, 40, 612, 616, 618, 620, 946
509.730	606
509.810	218
509.820	218
509.930	779, 781, 785, 787, 967
509.949	779, 781
509.957	779
510.031	332, 334, 409, 411, 413, 419, 461, 463, 465, 467, 469, 527, 529, 571, 581, 583, 585, 587, 589, 591, 593, 595, 597, 599, 601, 603, 607, 609, 613, 615, 617, 619, 621, 623, 643, 651, 653, 655, 657, 661, 663, 665, 685, 689, 691, 695, 699, 701, 703, 705, 707, 709, 711, 713, 715, 717, 718, 719, 721, 723, 725, 727, 731, 743, 745, 747, 749, 751, 753, 755, 757, 759, 761, 763, 765, 771, 773, 775, 777, 779, 781, 785, 787, 795, 796, 797, 802, 803, 811, 815, 817, 843, 863, 877, 881, 883, 889, 911, 929, 945, 947, 953, 955, 969, 995, 997, 999, 1001, 1003, 1005, 1009, 1011, 1013, 1015, 1017,

elring Das Original	
511.030	1019, 1021, 1023, 1025, 1027, 1029, 1031, 1033, 1035, 1039, 1047, 1049, 1051, 1053, 1055, 1077, 1079, 1081, 1083, 1093, 1095, 1099, 1101, 1103, 1105, 1107, 1109, 1111, 1113, 1115, 1117, 1119, 1121, 1123, 1125, 1127, 1129, 1133, 1135, 1137, 1143, 1145, 1151, 1153
511.040	1132
511.064	1132
512.220	640
512.270	490, 492
512.290	490, 492
512.330	520, 522
512.820	664, 968
512.850	658
512.930	658
513.330	1114, 1116
513.940	1115, 1117
514.161	11, 13, 637, 639, 867, 871, 873
514.192	13, 15, 867, 873
514.960	620
515.110	70, 76, 78
515.250	538
515.260	538
515.270	538
515.290	538
515.311	92
515.450	687, 695, 697
516.406	1139, 1141
517.120	95
517.171	94
518.030	640, 642, 884, 886, 894
518.250	628
518.260	628
518.760	799
519.440	266, 268, 318
519.530	622
520.690	665, 969
520.720	340, 344, 346, 384
520.780	340, 344, 346, 384
520.800	1028
520.830	1038
520.890	1110
521.090	813
521.100	589
521.339	42, 44, 656, 662, 1142, 1144
521.347	42, 44, 656, 662, 1142, 1144
521.355	42, 44, 656, 662, 1142, 1144
521.960	747, 929, 1105
522.120	518
522.130	516, 518
522.180	452, 454
522.190	414, 456
522.220	702
522.230	795, 797
522.407	1043
522.430	352



522.440	352
522.930	795, 797
522.940	795, 797
522.950	796
523.120	69, 71, 73, 75, 77, 81, 361
523.181	650
523.310	310
523.320	310
523.330	310
523.340	310
523.350	310
523.360	310
523.390	79
523.430	72, 74, 76, 360
523.440	78
523.470	699, 721, 723, 725, 771
523.650	77, 81
523.750	519
523.821	80
523.950	664, 968
524.160	16, 638, 640, 642, 882, 884, 886
524.215	663
524.281	662
524.330	665, 969
524.340	284
524.350	284
524.360	284
524.390	284
524.400	284
524.410	284
524.890	955
524.920	955
526.800	813
526.820	280, 282, 286, 288, 290, 292, 294, 296
527.110	150
527.140	1082
527.250	518
527.270	517, 519
527.291	332, 334, 409, 411, 413, 419, 461, 463, 465, 467, 469, 527, 529, 571, 581, 583, 585, 587, 589, 591, 593, 595, 597, 599, 601, 603, 607, 609, 613, 615, 617, 619, 621, 623, 643, 651, 653, 655, 657, 661, 663, 665, 685, 689, 691, 695, 699, 701, 703, 705, 707, 709, 711, 713, 715, 717, 718, 719, 721, 723, 725, 727, 731, 743, 745, 747, 749, 751, 753, 755, 757, 759, 761, 763, 765, 771, 773, 775, 777, 779, 781, 785, 787, 795, 796, 797, 802, 803, 811, 815, 817, 843, 863, 877, 881, 883, 889, 911, 929, 945, 947, 953, 955, 969, 995, 997, 999, 1001, 1003, 1005, 1009, 1011, 1013, 1015, 1017, 1019, 1021, 1023, 1025, 1027, 1029, 1031, 1033, 1035, 1039, 1047, 1049, 1051, 1053, 1055, 1077, 1079, 1081, 1083, 1093, 1095, 1099, 1101, 1103, 1105, 1107, 1109, 1111, 1113, 1115, 1117, 1119, 1121, 1123, 1125, 1127, 1129, 1133, 1135, 1137, 1143, 1145, 1151, 1153
527.450	418, 420, 444, 446, 448
527.550	748, 928, 930, 932, 1102
527.660	748, 928, 930, 932, 1102



527.770	78
527.780	664, 968
527.800	664, 968
527.910	591, 595, 599, 601
528.970	642, 650, 652, 654, 952
529.060	686, 692
529.250	712, 734
529.461	842
529.471	842
529.500	878
529.530	652
529.620	874
529.680	812
529.690	812
529.960	449, 451, 453, 455
530.060	448, 450, 452, 454
530.070	409, 421, 437, 439, 441, 443, 449, 451, 453, 455
530.080	890
530.140	450, 454
530.243	684
530.541	134, 136, 140, 142, 144, 1086, 1088
530.560	134, 136, 140, 142
530.580	106, 112, 114, 116, 362
530.590	88
530.610	104
530.800	71, 77, 79
530.810	71, 77, 79
530.930	329, 341, 343, 353, 383
530.982	329, 341, 343, 353, 383
531.050	862
531.381	656
531.422	150
531.450	608
531.460	608
531.470	608
534.180	1114, 1116
534.310	490, 520, 522
534.720	688
535.330	843, 863
537.540	448, 452
537.630	1011, 1019, 1029, 1035
537.850	490, 520, 522
537.890	491, 493, 499, 501, 519, 521, 523, 525
537.950	1131
538.080	23, 41, 613, 617, 619, 621, 947
539.200	208, 210, 212, 214, 226, 228, 230, 232, 234, 236, 238, 244, 250, 252, 258, 260, 262, 264, 370, 376
539.410	1018, 1028, 1034
539.420	409, 421, 437, 439, 441, 443, 449, 451, 453, 455, 515, 517, 519
539.440	608
539.690	592, 600, 602
540.470	660
540.540	748, 749, 928, 929, 930, 931, 932, 933, 1102, 1103
540.792	663



540.840	663
541.172	551, 553
541.510	1033
541.620	1123, 1127
542.000	146, 150
542.020	662
542.030	1017, 1019, 1029, 1033, 1035
542.041	662
542.050	626
542.160	588
542.181	152
542.430	545, 561
545.820	602
545.840	491, 493, 499, 519, 521, 523, 525
545.930	719
546.900	505, 507
547.477	148, 200, 202, 204
547.490	1150, 1152
547.500	1150, 1152
547.510	1150, 1152
547.920	999
548.141	142
548.181	146, 150
548.200	787, 789, 967, 969
548.930	349
550.570	590, 594, 600
550.680	1001, 1007, 1009, 1029, 1043, 1045, 1057, 1059, 1061, 1063, 1065, 1067, 1069, 1071, 1073, 1075, 1097, 1099
550.830	565
550.840	565
551.410	1053
553.190	73, 83, 85, 87, 89, 93, 119, 121, 127, 129, 131, 133, 149, 177, 179, 181, 183, 185, 199, 201, 203, 205, 207, 217, 219, 227, 229, 231, 233, 245, 247, 249, 255, 257, 259, 423, 425, 535, 537, 841, 863, 1085
553.480	995, 997
554.931	658
554.970	240, 242, 268, 270, 272, 274, 276, 278, 374
554.980	240, 242, 268, 270, 272, 274, 276, 278, 374
557.609	1044
557.617	1044
557.668	1044
557.856	1045
557.863	1045
558.141	1044
558.460	601
558.510	613
558.880	616, 618, 620
558.908	72
559.040	541, 561
560.000	621, 623
560.370	600
560.490	600
560.760	601
561.951	994, 998, 1006
561.960	601

elring Das Original	
562.000	601
562.090	615, 621, 623
562.100	601
562.250	267, 269, 319, 321, 381
562.260	219
562.645	1045, 1057, 1059, 1061, 1063, 1069, 1071, 1073
562.653	1045, 1047, 1049, 1051, 1053, 1055, 1057, 1059, 1061, 1063, 1065, 1067, 1069, 1071, 1073, 1075, 1077
562.661	1045
562.939	471, 563, 565
563.147	712, 714, 726, 734, 894
564.350	615, 621
564.640	196, 198
564.670	196
564.880	796
565.370	802
565.620	504, 506
566.820	336
567.388	176, 182
567.640	71, 73, 75, 77, 79, 89, 91, 93, 95, 97, 99, 101, 103, 105, 107, 109, 111, 113, 115, 117, 123, 125, 135, 137, 141, 143, 145, 147, 149, 151, 153, 155, 157, 159, 161, 163, 165, 167, 169, 171, 173, 175, 177, 185, 187, 189, 211, 213, 215, 217, 219, 233, 235, 237, 239, 251, 259, 261, 263, 265, 313, 321, 323, 325, 327, 355, 361, 363, 365, 367, 371, 373, 377, 379, 383, 649, 1087, 1089, 1091, 1147
567.818	474, 492
568.060	586
568.070	586
568.080	586
568.090	580
568.100	580
568.110	580
568.850	530
568.860	776, 1122, 1124, 1126
568.870	409
569.410	710, 876, 1024
569.450	1080
569.460	1036, 1038, 1078, 1080, 1092, 1094
569.480	1130
569.650	1030
569.670	783, 955, 957, 961
569.770	1106, 1108, 1110, 1122, 1132
569.802	710, 876, 1024
569.812	710, 876, 1024
569.822	710, 876, 1024
569.832	710, 876, 1024
569.842	710, 876, 1024
569.850	1080
569.860	1130
569.871	1030, 1032
569.970	1028
570.870	99, 101, 163
570.910	698, 706, 708, 876
570.920	698, 708, 1016, 1018, 1020, 1026

elring Das Original	
571.730	582
571.770	643, 885, 895
572.310	541, 545, 559, 561
572.630	410, 412
572.700	411, 461, 463, 465
572.830	1128
572.860	746, 928, 1104
572.890	1126
573.350	1122, 1124, 1126
573.370	1126
573.380	776
573.486	1044
574.120	241, 243, 269, 271, 273, 275, 277, 279, 375
574.190	665, 667
574.310	640
574.330	609
574.630	9, 637, 837, 839
574.651	339
574.660	339
574.760	842
574.770	843, 863
575.051	452, 454
575.250	622, 624, 626
575.260	622, 624, 626
575.430	623, 625, 627
575.510	660
575.970	419, 461, 463, 465, 467, 469, 527, 529
576.280	98, 100, 162, 170
576.320	813
576.330	812
577.230	418, 460, 462, 464
577.240	142, 144, 1088
577.260	857, 859
577.540	689, 691
577.630	685, 689
577.730	777
578.428	812
580.075	1044
580.083	1044
580.198	1148
581.128	728, 730, 734, 736, 738, 740, 898, 900, 902
581.305	728, 730, 734, 736, 738, 740, 898, 900, 902
582.000	419
582.190	408, 410, 412, 436, 438, 460, 462, 464
582.530	685, 689, 691
582.580	690
582.630	740, 898
582.840	627
582.850	627
583.030	609
583.050	609, 641, 643, 885, 887, 895
583.200	590, 594, 600
584.140	515, 517, 519
584.160	421, 437, 439, 441, 443, 449, 451, 453, 455, 505, 507, 515, 517, 519
584.280	609

elring Das Original	
584.450	514, 516, 518
584.500	652
584.570	590, 594, 600
584.600	507, 515, 517, 519
584.820	505, 507, 515, 517, 519
584.850	800
584.860	802
584.880	799
584.890	780, 786
584.910	781, 787
584.930	609
584.940	803
584.950	490, 518, 520, 522
585.020	26, 28, 30, 916, 918
585.250	590, 594, 598, 600
585.260	590, 594, 598, 600
585.620	622, 624, 626
586.210	684, 814
586.270	664, 968
586.280	664, 968
586.331	411
586.360	280, 282, 284, 286, 288, 290, 292, 294, 296, 298, 300, 302, 304, 306, 308, 310, 312
586.480	685, 815
586.530	786, 968
586.540	786, 968
586.550	411, 413, 419, 461, 463, 465, 467, 469, 527, 529
586.641	475, 535, 537
586.668	415, 425, 431, 473, 475, 493
586.676	421, 431, 433, 435, 437, 473, 475, 477, 479, 481, 483, 485, 489, 493, 495, 497, 503, 527, 531, 533, 539, 541, 555, 557, 559, 563
586.693	589, 597, 605, 611, 615
586.730	995, 997, 999, 1001, 1007, 1009
587.044	423, 425
587.100	15, 33, 637, 639, 715, 837, 839, 841, 843, 845, 847, 849, 851, 853, 855, 857, 859, 861, 863, 865, 867, 869, 871, 875, 879, 881, 883, 891, 921, 923, 1001, 1005
587.150	746, 928, 1104
587.210	747, 929
587.250	746, 928, 1104
587.430	583, 593, 595
587.486	1005, 1013, 1015, 1041, 1043, 1045
587.880	589, 591, 603
588.340	410, 412
588.371	467
588.450	156
588.620	653
588.690	75, 125, 127, 191, 193, 195, 197, 199, 361, 369
588.880	157, 159
589.080	689, 691
589.110	786, 788, 966, 968
589.490	684, 814
589.600	224, 374
589.650	224, 374



589.660	224, 374
589.680	101, 103, 109, 111, 113, 201, 203, 209, 229, 231, 247, 259
589.740	1139, 1151
589.830	94, 96
589.841	507
590.080	786, 788, 966, 968
590.260	797
590.410	607
590.420	582
590.569	1096, 1098
590.577	1098
590.585	1098
590.615	1042
590.797	585, 589, 591, 595, 597, 599, 601, 883
590.917	712, 734
590.932	712, 726, 734, 762, 764, 766, 894, 938, 940
590.959	713, 735, 763, 765, 767, 939
590.984	713, 715, 727, 729, 731, 733, 735, 737, 739, 741, 763, 765, 767, 769, 895, 897, 899, 901, 903, 939, 941, 943
591.076	836, 840, 842, 846, 850
591.410	623, 627
591.840	69, 71, 73, 75, 77, 81, 123, 125, 187, 189, 217, 219, 225, 241, 243, 265, 267, 269, 271, 273, 275, 277, 279, 281, 283, 285, 287, 289, 291, 293, 295, 297, 299, 301, 303, 305, 307, 309, 313, 315, 317, 319, 321, 323, 325, 331, 333, 335, 337, 339, 341, 343, 345, 347, 349, 353, 365, 367, 369, 373, 375, 377, 379, 381, 383, 385
592.380	463, 467
592.400	607
592.540	684
592.550	688
592.640	684, 688, 690
592.910	16, 34, 638, 644, 882, 884, 886, 924, 926
593.300	418, 460, 462, 464, 466, 468
593.390	409, 437, 439, 441, 443
593.520	408
593.930	158, 160, 162, 164, 166, 168, 170
593.940	158, 160, 162, 164, 166, 168, 170
593.950	158, 160, 162, 164, 166, 168, 170
593.960	546, 550
595.090	500
595.170	585, 589, 591, 613, 617, 619, 621, 947
595.180	73, 75, 77
596.470	542, 546, 548, 550
597.000	436, 438, 440, 442
597.110	408
597.120	408
597.130	408
597.140	460, 462, 464
597.150	460, 462, 464
597.170	418, 460, 462, 464, 466, 468
597.400	583, 593, 595
597.480	606
598.080	1114, 1116
598.610	685, 689



598.620	796
598.760	591, 595, 599, 601
599.077	563, 565
599.160	22, 592, 600, 602, 894
599.170	796
599.210	596
599.290	592, 594
599.402	1130, 1140, 1142
599.590	332
599.600	332
612.001	532
612.282	652
612.332	656, 658
612.440	563
616.510	1147
617.270	1146
617.820	622, 624
618.280	622, 624
619.090	622, 624
619.771	128, 130, 132, 138, 144, 1084, 1086, 1090
620.280	128, 130, 132, 1084
623.270	199, 201, 203
623.440	204
625.400	177, 183
625.760	89, 91, 143, 145, 147, 149, 151, 1087, 1089, 1091
626.727	18, 20, 38, 892
626.761	40
627.160	216, 218
627.350	217
627.580	218
627.651	312, 378
627.690	216, 218
627.811	178, 180, 182, 184
629.363	88
630.190	86
630.670	182
630.970	101, 103, 105
631.580	553
631.590	553
632.070	540, 544, 558, 560
632.190	206
632.430	712
632.450	712
632.510	329, 349, 351
632.565	250, 252, 258, 260, 262, 264, 376
632.580	888
632.690	209, 227, 229, 231, 233, 245, 247, 249, 255, 257, 259
632.700	209, 227, 229, 231, 233, 245, 247, 249, 255, 257, 259
632.730	580
632.740	226, 228, 230, 232, 244, 254, 256, 258
632.760	211, 215, 251, 253, 259, 261, 263
633.230	607
633.330	656, 658



633.350	100, 102, 104, 106, 108, 110, 112, 114, 116, 360, 362
633.550	607
633.760	69, 71
634.450	527, 539, 541, 555, 557
634.600	888
634.660	684, 688
634.670	888
634.760	713
634.970	408, 412, 418, 440, 442, 462, 466, 468
636.250	306, 310, 312
638.181	527, 539, 541, 545, 555, 557, 559, 561, 563
638.191	527, 539, 541, 555, 557, 559, 561, 563
642.100	22, 24, 26, 28, 30, 606, 608, 904, 906, 908, 910, 912, 914, 916, 918, 920
642.110	415, 457, 459
642.470	889
642.490	794, 796
642.530	684
642.540	688
642.550	691
642.680	685, 815
643.040	1115, 1117
644.760	638, 642
645.710	589, 597
645.842	604, 606
645.910	605, 607, 611, 613, 615, 617, 619
646.370	610, 614
646.440	1138, 1140
646.480	1078, 1080
646.540	1029, 1043, 1097, 1099
646.550	1029, 1043, 1097, 1099
646.631	1036, 1038
646.813	1008
647.070	639, 643
648.050	408
648.080	408
648.130	460, 462, 464
648.160	436, 440
648.280	549, 551
648.330	440, 442
648.340	436, 438
648.450	438, 442
648.530	500
648.550	501
648.560	550
648.590	552
648.620	410, 412
648.640	411, 413
648.661	332, 334, 409, 411, 413, 419, 461, 463, 465, 467, 469, 527, 529, 571, 581, 583, 585, 587, 589, 591, 593, 595, 597, 599, 601, 603, 607, 609, 613, 615, 617, 619, 621, 623, 643, 651, 653, 655, 657, 661, 663, 665, 685, 689, 691, 695, 699, 701, 703, 705, 707, 709, 711, 713, 715, 717, 718, 719, 721, 723, 725, 727, 731, 743, 745, 747, 749, 751, 753, 755, 757, 759, 761, 763, 765, 771, 773, 775, 777, 779, 781, 785, 787, 795, 796, 797, 802, 803, 811, 815,

elring Das Original	
	817, 843, 863, 877, 881, 883, 889, 911, 929, 945, 947, 953, 955, 969, 995, 997, 999, 1001, 1003, 1005, 1009, 1011, 1013, 1015, 1017, 1019, 1021, 1023, 1025, 1027, 1029, 1031, 1033, 1035, 1039, 1047, 1049, 1051, 1053, 1055, 1077, 1079, 1081, 1083, 1093, 1095, 1099, 1101, 1103, 1105, 1107, 1109, 1111, 1113, 1115, 1117, 1119, 1121, 1123, 1125, 1127, 1129, 1133, 1135, 1137, 1143, 1145, 1151, 1153
649.250	1083, 1111, 1113, 1115, 1117, 1119, 1129, 1135, 1137
649.390	796
649.400	794
649.880	420, 444
649.910	167, 169, 173
650.050	690
650.330	889
650.420	994, 996
651.020	79
651.340	17, 639, 641, 643, 887
651.930	778, 948, 950, 952
654.770	968
654.780	968
655.190	725, 745
655.290	626
655.321	856, 858
655.340	313, 355, 379
655.360	142, 144, 150, 1086, 1088, 1090
655.380	903
655.400	781, 787
655.420	781, 787
655.450	724
655.460	882
655.540	664
655.570	558
655.581	414, 456, 458, 500
655.650	781, 787
655.750	968
655.840	123, 125, 185, 187, 189, 365, 367
655.860	185
655.881	415, 457, 459
655.980	8, 636, 838
656.160	547, 549, 551, 553, 559, 561
656.350	742, 744, 770, 1104
656.370	642, 650
656.420	642, 650, 652, 654, 952
657.030	642, 650, 652, 654, 762, 778, 952
657.110	994, 996
657.120	995, 997
658.190	448, 450, 452, 454
658.200	448, 450, 452, 454
658.210	448, 450, 452, 454
659.110	558
659.120	558
659.440	615, 621, 623
659.500	600
660.260	324, 1146
660.270	326

elring Das Original	
660.280	184
660.360	491, 493, 499, 501, 519, 521, 523, 525, 527, 529
660.370	490, 520, 522
670.700	88
670.710	88
670.720	128, 130, 132, 138, 1084, 1086
670.730	100, 102, 106, 108, 110, 112, 114, 360
670.740	208, 226, 228, 230, 232, 244, 250, 252, 254, 256, 258
670.750	178, 180, 182
670.780	415, 417, 425, 427
671.100	891, 923
685.150	19, 21, 37, 39, 893
685.330	656
685.340	663
685.662	122, 124, 186, 188, 364, 366
686.870	663
687.330	22, 24, 26, 28, 30, 32, 34, 36, 644, 646, 648, 904, 906, 908, 910, 912, 914, 916, 918, 920, 924, 926
687.346	938, 956
687.350	644, 646, 648, 924, 926
687.510	657, 659
687.750	684, 814
687.800	684, 814
687.820	744
687.840	684, 814
687.860	724
688.000	724, 744
688.050	15, 637, 845, 847, 851, 853, 865, 867, 869, 1001
688.250	90
688.412	798
688.422	800
688.580	13, 15, 639, 845, 851, 853, 869, 871, 873
689.350	584, 588
689.726	654, 658
689.940	15, 639, 865, 871
689.960	41, 43, 953
689.970	1112, 1114, 1116
690.000	1115, 1117
690.070	43, 953
690.110	327, 329, 353
690.140	41, 43, 953
690.396	654, 658
690.426	654, 658
690.500	608
690.531	655, 659
690.721	653
690.740	585, 589
690.750	589
691.130	588
691.370	584, 588, 590
691.390	553
691.403	553
691.780	125, 127, 189, 191, 193, 195, 197, 199, 369
692.530	548

elring Das Original	
692.751	148, 200, 202, 204
692.760	665, 969
693.057	415, 425, 427
693.201	995, 997, 999, 1001, 1149
693.553	996, 1000
693.580	298, 302, 304
693.660	713, 735
693.670	593, 595
693.848	92, 118, 120
693.880	34, 644, 924, 926
694.011	474, 492
694.300	685, 815
694.350	880
694.360	664, 968
694.410	684, 814
694.502	1130, 1140, 1142
694.510	1130, 1140, 1142
694.711	605, 611
694.770	23, 41, 605, 607, 611, 613, 615, 617, 619, 947
695.560	161, 163, 165, 167
696.000	159, 165, 167, 169, 171
696.080	994, 996
696.180	333, 335
696.200	333, 335
697.520	795, 797
697.530	795, 797
697.600	795
698.430	88, 90
698.920	837
698.970	563
699.310	714
699.320	714
701.289	15, 19, 21, 37, 39, 43, 45, 71, 77, 79, 89, 91, 129, 131, 133, 135, 137, 139, 141, 143, 145, 147, 149, 151, 177, 179, 181, 183, 185, 199, 201, 203, 209, 227, 229, 231, 233, 245, 247, 249, 255, 257, 259, 349, 351, 415, 417, 425, 427, 429, 431, 433, 437, 471, 473, 475, 477, 489, 493, 563, 565, 685, 687, 693, 695, 697, 705, 719, 735, 763, 779, 781, 799, 805, 837, 839, 841, 843, 845, 847, 849, 851, 853, 865, 875, 881, 883, 893, 937, 939, 957, 1085, 1087, 1089, 1091, 1147
702.230	500
702.269	589, 591, 597, 605, 607, 611, 613, 615, 617, 619, 883
702.286	604
702.294	604, 610
702.331	605, 611
702.367	604
702.383	610
702.460	409
702.520	410, 412
702.530	412
702.570	888
702.620	500
702.706	73, 83, 85, 87, 89, 93, 119, 121, 127, 129, 131, 133, 177, 179, 181, 183, 185, 423, 425, 841, 863, 1085

elring Das Original	
702.994	415, 417, 421, 423, 425, 427, 429, 431, 433, 435, 437, 471, 473, 475, 477, 479, 481, 483, 485, 487, 489, 493, 495, 497, 499, 503, 533, 535, 537
703.532	414, 424
703.550	409
703.871	421, 431, 445, 489, 509
703.930	29, 919, 921
703.940	31, 917
703.950	77
703.960	103, 105, 107, 109, 113, 115, 117, 363
703.970	129, 131, 139
703.980	133, 139, 143, 145, 147, 151, 1085, 1091
703.990	133
704.010	135, 1085, 1087
704.020	137, 141, 143, 1089, 1091
704.040	147
704.050	221, 223, 225, 373
704.939	1012, 1014
704.947	1012, 1014
705.100	10, 860
705.140	10, 860
705.300	11, 861
705.811	1013, 1015, 1041, 1077
706.440	640, 884, 886
706.870	664, 666
707.120	8, 836, 840
707.350	685, 689, 691
707.450	995, 997, 999
708.100	641, 643, 885, 887, 895
708.610	1135, 1137
709.040	1119, 1135, 1137
709.690	1110, 1112, 1114, 1116, 1118, 1134, 1136
709.740	1134, 1136
710.160	836
710.232	838, 840
710.242	838, 840
710.251	838, 840
710.261	846
710.271	846
710.280	846, 850, 852
710.291	846
710.301	846
710.320	958
710.350	958
710.360	880
710.370	880
710.380	880
710.392	874
710.401	874
710.410	874
710.421	892
710.431	892
710.440	18, 20, 892
710.451	18, 20
710.461	18, 20
710.520	938

elring Das Original	
710.770	622
710.802	355
710.840	9, 637, 837, 839, 841
711.662	1013
711.671	778
711.720	803, 805
711.730	650
711.800	796
711.830	596
711.840	778, 780
711.880	779
711.910	779
711.930	778
711.990	562
712.000	562
712.170	663
712.470	182
712.480	604, 606, 610, 612, 614, 616, 618
712.821	780
712.830	780, 786
713.070	686
713.110	994, 996
713.163	514, 516
713.173	514, 516
713.183	514, 518
713.490	326
714.190	563
714.230	1146
714.351	801
714.520	703
714.590	701, 1015
714.600	711, 877, 1025
714.610	753, 755, 759, 761, 931, 937
714.620	751, 759, 761, 775, 935
714.630	757, 759, 761
714.640	749, 929, 931, 933, 1103
714.750	540, 544, 558, 560
714.810	785, 963, 965
714.860	801
715.310	855, 857
715.320	587, 855, 857, 1005
715.550	421, 445
715.620	783
715.740	657, 659
715.830	216, 372
715.840	216, 372
716.760	9, 857, 859
717.380	324, 382
717.400	324, 382
717.450	325, 327
717.570	662
717.580	152
717.710	881
717.930	333, 335
717.951	105, 111, 117
718.051	98, 100

elring Das Original	
718.061	98, 100
718.071	98, 100
718.081	92
718.200	9, 11, 587, 637, 691, 857, 859, 861
718.210	779, 787, 789, 949, 951, 953, 967, 969
718.220	778, 948, 950, 952
718.240	727
718.311	706, 708, 712, 876, 1026
718.321	706, 708, 712, 876, 1026
718.331	706, 708, 712, 876, 1026
718.341	706, 708, 712, 876, 1026
718.351	706, 708, 712, 876, 1026
718.411	13, 15, 637, 639, 869, 871, 873
718.420	184
718.430	184
718.440	184, 186, 364
718.610	732, 896
718.680	779, 949, 951
718.890	594
719.780	653
719.790	653
719.800	652
720.220	216, 320, 322, 372, 382
720.230	216, 320, 322, 372, 382
720.420	76, 78, 1090
721.972	74, 76, 360
721.982	72
722.050	147, 149
722.080	94, 96, 776, 1122, 1124, 1126, 1150, 1152
722.090	94, 96
722.100	94, 96
722.140	779, 949, 951, 953
722.400	36
722.503	414, 456, 458
724.250	217, 225, 265, 267, 315, 317, 319, 321, 323, 325, 373, 375, 377, 379, 381, 383
724.280	14, 636, 844, 850, 852, 866, 868, 1000
724.290	794
724.330	852
724.341	142
724.360	602
724.470	420, 444
724.500	746, 760, 928
724.510	746, 760, 928
724.580	28, 30, 912, 916, 918, 920
724.590	71, 73, 75, 79, 91, 93, 95, 97, 99, 101, 103, 105, 107, 109, 111, 113, 115, 117, 123, 125, 127, 149, 151, 153, 155, 157, 159, 161, 163, 165, 167, 169, 171, 185, 187, 189, 191, 193, 195, 197, 199, 211, 213, 215, 217, 219, 221, 223, 225, 233, 235, 237, 239, 241, 243, 251, 253, 259, 261, 263, 265, 267, 269, 271, 273, 275, 277, 279, 281, 283, 285, 287, 289, 291, 293, 295, 297, 299, 301, 303, 305, 307, 309, 311, 313, 315, 317, 319, 321, 323, 325, 327, 329, 331, 333, 335, 337, 339, 341, 343, 345, 347, 349, 351, 353, 355, 361, 363, 365, 367, 369, 371, 373, 375, 377, 379, 381, 383, 385, 649, 1147
724.760	32, 890, 920, 922

elring Das Original	
724.770	32, 890, 920, 922
724.780	32, 890, 920, 922
724.790	32, 890, 920, 922
724.940	201
725.160	264, 266, 320, 322, 376, 378, 382
725.190	264, 266, 320, 322, 376, 378, 382
725.210	72, 74
725.330	540, 544, 558, 560
725.340	540, 544, 558, 560
725.390	498
725.790	849
725.840	937, 939, 957
725.850	41, 937, 939, 955, 957
725.860	216, 320, 322, 372, 382
725.870	216, 320, 322, 372, 382
726.090	698, 700, 706, 708, 710, 876, 1014, 1016, 1018, 1020, 1024, 1026
726.290	142, 144, 1088
726.300	1146
726.740	154, 156, 158
726.840	154, 156, 158
726.850	154, 156, 158
727.471	511
727.720	421, 445
727.730	421, 445
727.751	420, 444
727.830	499
727.920	563
728.090	684, 814
728.130	720
728.550	217, 225, 265, 267, 315, 317, 319, 321, 323, 325, 373, 375, 377, 379, 381, 383
728.570	325
728.600	543
728.610	543
728.670	845, 851, 853
728.880	211, 213, 215, 219, 221, 223, 225, 233, 235, 237, 239, 251, 253, 259, 261, 263, 265, 371, 373, 377
728.960	849
729.040	418, 720, 722, 724
729.041	418, 720, 722, 724
729.050	698, 722
729.571	99, 101, 161, 163, 167, 171
729.861	106, 114, 116, 362
729.880	770, 772, 944, 1120
729.990	610
730.130	149, 199, 201, 203, 205, 207, 217, 219
730.300	72, 74
730.310	11, 867
730.792	620, 622
730.830	718
732.090	94, 96
732.100	94, 96
732.110	94, 96
732.160	770, 772, 944, 1120
732.170	770, 772, 944, 1120

elring Das Original	
732.180	770, 772, 944, 1120
732.190	770, 772, 944, 1120
732.640	652
732.841	72
732.970	850
733.070	603
733.100	776, 946, 1122, 1124, 1126
733.350	153, 649
733.460	152, 154
733.530	778, 948, 950
733.541	948
733.542	948
733.570	1109, 1111, 1123
733.870	1047, 1049, 1051, 1055
734.230	41, 43
734.240	769
734.250	1147
734.370	729, 735
734.720	544, 560
734.790	540, 544, 558
734.820	1107, 1109, 1111
734.830	1107, 1109
735.230	10, 866
735.250	543
735.260	543
735.280	544
735.370	605, 607, 611
735.400	242, 278, 374
735.430	242, 278, 374
735.450	242, 278, 374
735.470	242, 278, 374
735.490	242, 278, 374
735.500	242, 278, 374
735.570	1087
735.690	146, 148, 150, 152, 648
735.700	880
735.710	881
735.850	123, 125
736.180	105, 107
736.220	560
736.261	518
736.271	518
736.480	542
736.520	449, 453
736.630	608
736.650	153, 155
736.810	881
736.880	104, 106
737.250	665
738.190	501
738.340	471, 487, 499
738.832	415, 457, 459
739.060	459
740.210	498
740.240	498
740.280	492, 524

elring Das Original	
740.290	492, 524
740.421	562
740.790	149, 649
741.800	74
741.910	498
742.950	653
742.960	653
743.220	558
743.381	606, 608
743.450	607, 609
743.560	721, 725
744.150	584
744.264	354
744.321	185
744.361	184
744.472	600
744.482	600
744.492	600
745.110	775
745.120	773, 945
745.190	540
745.631	714, 726
745.740	799, 801
746.050	71
746.140	800
746.400	653, 657, 659
746.450	613
746.902	416, 418, 428, 444, 446, 448
747.080	698, 700, 706, 708, 710, 876, 1014, 1016, 1018, 1020, 1024, 1026
747.210	419, 699, 721, 723, 725
747.340	880
747.350	880
747.720	152
748.030	94
748.230	94
748.510	17, 35, 639, 645, 883, 885, 887, 925, 927
748.530	33, 35, 645, 647, 649, 925, 927
748.591	16, 32, 34, 36, 638, 640, 642, 644, 646, 648, 882, 884, 886, 924, 926
748.889	415, 425
748.995	414, 424
749.250	779, 949, 951, 953
749.370	534, 536
750.330	221, 223, 225, 373
750.476	1005, 1013, 1015, 1037, 1039, 1041, 1043, 1045, 1077, 1079, 1081, 1093, 1095, 1111, 1131
750.492	534, 536
750.710	352
750.931	743, 745, 771, 1105
751.040	1001, 1007, 1009
751.066	994, 998, 1006
751.610	415, 457, 459, 491, 493, 499, 501, 519, 521, 523, 525
751.970	584, 588, 590
752.060	543
752.131	542

elring Das Original	
752.215	432, 434, 436
752.691	726
752.860	1002, 1010
753.020	1003, 1011, 1013
753.130	654, 658
753.300	352
755.141	589, 595, 597
755.178	588
755.991	436, 470
756.820	1113, 1115, 1117
756.920	1113, 1115, 1117
757.292	779, 781, 1005, 1013, 1015, 1037, 1039, 1041, 1043, 1045, 1077, 1079, 1081, 1093, 1095, 1111
757.497	591, 595, 599, 601, 839, 841, 1005, 1013, 1015, 1029, 1041, 1043, 1045, 1077, 1097, 1099, 1111, 1131, 1149
757.691	206
757.756	73, 83, 85, 87, 93, 119, 121
758.230	728, 738
758.240	768
758.260	768, 942
758.280	712, 714, 726, 734
758.290	714, 726, 894
758.300	684, 686, 692, 694, 696, 718, 864
758.370	692
758.400	704
758.680	32, 34, 36, 644, 646, 648, 924, 926
758.690	32, 34, 36, 644, 646, 648, 924, 926
758.710	32, 34, 36, 644, 646, 648, 924, 926
758.825	87, 119, 127, 177
759.180	802
759.371	798, 804
759.970	662
760.090	652
760.120	656, 658
760.300	782, 954, 956, 958, 960, 962, 964
760.510	32, 890, 920, 922
760.720	14, 636, 836, 840, 842, 844, 846, 848, 850, 852, 864, 866, 868, 1000
760.870	714, 844, 862, 874, 878, 880
761.031	1000, 1002, 1008, 1010, 1012, 1030, 1032, 1034
761.041	701, 703, 711, 877, 1015, 1025
761.265	1149
761.293	882
761.389	1047, 1049, 1051, 1053, 1055, 1057, 1059, 1061, 1063, 1065, 1067, 1071, 1073, 1075, 1077
761.796	417, 427, 429, 437, 471
762.016	437, 471
762.033	415, 417, 425, 427
762.041	436, 470
762.084	425, 427
762.199	535, 537
762.811	652
762.821	656, 658
762.874	1004, 1012, 1014, 1040, 1042, 1044

elring Das Original	
763.071	954, 956, 960
763.136	955, 961
763.144	955, 957, 959, 961
763.713	1001, 1007, 1009, 1029, 1043, 1045, 1057, 1059, 1061, 1063, 1065, 1067, 1069, 1071, 1073, 1075, 1097, 1099
763.880	640, 642, 884, 886, 894
763.918	603, 815, 817, 819
764.221	1004, 1012, 1014, 1040, 1042, 1044
764.248	1042, 1096, 1098
764.470	1150, 1152
764.750	1150, 1152
764.800	1151, 1153
764.907	534, 536
764.915	534, 536
765.112	997, 1001, 1007, 1009
765.636	126, 176
765.860	995, 997, 999
766.267	426
766.390	589, 595, 597
766.540	614
766.615	997, 1001, 1007, 1009, 1111, 1131
766.675	996, 1000
766.682	996, 1000
766.691	1006, 1008
766.704	1006, 1008
766.790	366
766.940	298, 302, 304
767.110	622, 624, 626
767.824	227, 231, 245, 255, 257
767.859	426
767.867	426, 428
767.891	416, 426, 428, 532
767.907	227, 231, 245, 255, 257
768.104	605, 611, 615
768.694	1040
768.716	1040, 1042
770.330	995, 997
770.530	124, 126, 190, 192, 194, 196
771.310	1110, 1118
771.320	1111, 1119
771.330	1111, 1119
772.976	474
772.984	474
773.130	994, 996
773.410	584, 588, 590
773.440	607
773.470	778, 780
773.530	1133
773.582	799, 805
773.630	589, 603, 605, 611, 613, 615
773.650	732, 896
773.660	732, 896
773.700	798, 804
773.730	733, 737, 897
773.740	695, 697, 705, 719
773.800	733, 897

elring Das Original	
773.810	733, 897
773.890	526
773.900	526
773.910	526
773.950	768, 942
773.990	32, 890, 920, 922
774.332	423, 425
774.341	423, 425
774.390	415, 417, 423, 425, 427, 429, 431, 433, 435, 437, 471, 473, 475, 477, 479, 485, 487, 493, 495, 497, 499, 503, 527, 531, 533, 535, 537, 541, 563, 565
774.456	535, 537
774.460	581, 583, 585, 591, 595, 597, 599, 601, 609, 613, 615, 617, 661, 731
774.480	533, 543
774.553	431, 473, 475, 493
774.561	431, 473, 475, 493
774.669	535, 537
774.677	535, 537
774.693	430, 472, 474, 492
774.715	534, 536
774.731	72, 82, 84, 86, 92, 118, 120, 126, 176
774.847	422, 424
774.855	422, 424
774.890	797
774.910	74
774.928	422, 424
774.936	474
774.940	802
774.960	76
775.578	590, 596
776.327	803
776.416	684, 686, 692, 694, 696, 718, 864
776.602	431, 473, 493
777.471	811
777.750	1152
777.820	1152
777.850	1152
778.420	795
779.020	794
779.140	795
779.150	794
779.190	684, 688
779.200	690
779.290	794
779.310	794, 796
779.610	68
779.670	584, 588
779.800	584, 588
780.660	332, 334
780.910	778
781.240	1110, 1116, 1118, 1136
783.160	642, 650
783.930	224, 266, 314, 318, 374, 378
784.530	168
784.680	526, 528

elring Das Original	
784.950	408
785.070	78
786.220	166, 168, 174, 176
786.230	167, 169, 173, 175, 177
786.270	167, 169, 173, 175
786.290	169, 175, 177
786.500	995, 997, 999, 1001, 1005, 1007, 1009, 1013, 1015, 1029, 1037, 1039, 1041, 1043, 1045, 1077, 1079, 1081, 1095, 1097, 1099, 1111, 1131, 1149
788.850	655, 659
789.180	16, 638, 640, 642, 882, 884, 886
789.190	16, 638, 640, 642, 882, 884, 886
789.200	16, 638, 640, 642, 882, 884, 886
789.400	587
789.720	606, 608
789.900	8, 636, 856, 858, 860
790.220	662
790.323	691
790.620	1002
790.690	770, 772, 944, 1120
790.860	783, 785, 955, 957, 959, 961, 963, 965, 967
792.020	80
792.220	803
792.230	745, 771, 1105
793.020	414, 456, 458
793.120	410
793.230	125, 127, 189, 193, 195
793.380	299, 303, 305, 307, 313
793.390	588
793.430	588
793.570	742, 744, 770, 1104
793.630	80
794.470	462, 466, 468
794.480	526, 528
794.660	460, 462, 464
794.680	418, 462, 466, 468
794.700	526, 528
794.710	526
794.720	500
794.870	542, 548, 552
794.880	542, 548, 552
794.920	720
794.950	796
794.960	797
795.100	712
795.120	548, 550
795.130	548, 550
795.150	802
795.330	408
796.160	266, 316, 318, 380
796.170	266, 316, 318, 380
796.230	11, 13, 637, 867, 871
796.280	418, 460, 462, 464, 466, 468
796.400	159, 161, 163, 165, 167, 171
796.460	315, 319, 379
796.490	607

elring Das Original	
797.560	191, 193, 195, 197, 199, 219, 299, 303, 305, 307, 311, 331, 333, 369
797.750	542, 548, 552
797.800	689
797.820	500
798.040	211, 213, 215, 233, 235, 237, 239, 261, 263, 265, 329, 337, 339, 377
798.150	889
798.310	1151, 1153
798.530	333, 335
798.660	123, 125, 127, 187, 189, 191, 193, 195, 197, 199, 365, 367, 369
798.670	124, 126, 188, 192, 194, 196
801.470	490, 520, 522, 524
801.650	803
802.661	420, 430, 444
802.700	534, 536
802.720	422, 424
802.740	432, 476, 478, 480, 482, 484, 494, 496, 502, 530
802.760	414, 416, 424, 426, 428
802.790	526, 538, 540, 554, 556, 558
802.801	488, 496, 508, 512
802.820	434, 436, 470, 480, 482, 484, 486, 494, 496, 498, 562, 564
802.860	1042, 1096, 1098
802.870	1036, 1038, 1078, 1080, 1092, 1094
802.880	1056, 1058, 1060, 1062, 1064, 1066, 1070, 1072, 1074
802.900	1110, 1130
802.910	996, 1000, 1006, 1008
802.930	1138, 1140
802.940	1044, 1056, 1058, 1060, 1062, 1068, 1070, 1072
803.010	604, 606, 610, 612, 614, 616, 618
803.060	592, 600, 602, 882
803.330	645, 647, 925
803.630	612, 620
803.740	72, 94
803.780	527, 539, 541, 555, 557
804.250	208, 226, 228, 230, 232, 244, 246, 248, 254, 256, 258
804.850	87, 89, 101, 103, 105, 107, 109, 111, 113, 115, 119, 121, 129, 131, 133, 139, 145, 149, 177, 179, 181, 183, 185, 199, 201, 203, 205, 207, 217, 219, 361, 1085, 1087, 1091
804.870	88, 90
805.070	1112, 1114
805.180	589
806.070	1114
806.390	1113, 1115, 1117
806.710	1098, 1100
806.850	1098, 1100
807.574	324
807.801	616, 946
807.890	848, 864
808.080	218
808.524	882
808.610	883

elring Das Original	
809.241	883
809.333	585, 589, 591
809.400	602
810.350	600
810.550	240, 242, 268, 270, 272, 274, 276, 278, 374
810.851	431, 473, 493
811.050	889
811.220	888
811.319	473, 475
811.386	473
811.530	504, 506
811.540	98, 100, 160, 162, 164, 166, 168, 170, 174, 176
811.620	606
811.653	433, 477
811.670	600
812.030	614, 620
812.170	601
812.200	600
812.288	526
812.296	526
812.773	269, 271, 273, 327, 329, 337, 341, 343, 349, 351, 353, 383
813.036	69, 71, 73, 75, 77, 81, 189, 217, 225, 241, 243, 265, 267, 269, 271, 273, 275, 277, 279, 281, 283, 285, 287, 289, 291, 293, 295, 297, 299, 301, 303, 305, 307, 309, 313, 315, 317, 319, 321, 323, 325, 331, 333, 335, 337, 339, 341, 343, 345, 347, 349, 353, 365, 367, 369, 373, 375, 377, 379, 381, 383, 385, 705, 725, 727, 729, 731, 733, 737, 739, 741, 745, 747, 749, 751, 753, 755, 757, 759, 761, 763, 765, 767, 769, 773, 775, 779, 895, 897, 899, 901, 929, 931, 933, 935, 937, 939, 941, 943, 945
813.052	651, 685, 687, 689, 691, 693, 695, 697, 699, 713, 715, 721, 723, 725, 729, 735, 737, 743, 763, 767, 771, 779, 781, 787, 795, 797, 799, 803, 805, 889, 903, 1019, 1021
813.087	1131, 1141, 1143
813.133	627
813.168	269, 271, 273, 327, 329, 337, 341, 343, 349, 351, 353, 383
814.110	81
814.140	20
814.262	1004, 1040, 1042, 1044
815.187	73, 83, 85, 87, 93, 119, 121, 127, 129, 131, 133, 135, 137, 139, 141, 143, 145, 149, 177, 179, 185, 199, 201, 203, 205, 207, 217, 219, 1085, 1087, 1091
816.160	8, 836
816.507	201, 205
816.982	432, 476
817.384	430, 472
817.430	414, 424
817.644	563, 565
818.399	527, 539, 541, 555, 557, 559, 563, 565
818.704	562, 564
818.747	474, 492
818.828	72
818.900	1126
818.910	1126

elring Das Original	
818.920	1126
819.808	72
819.817	86, 88, 92, 118, 120, 126, 176, 178, 180, 182, 184
819.824	82, 84, 128, 130, 132, 134, 136, 138, 140, 142, 144, 1084, 1086, 1090
819.832	82
819.840	176, 182
819.850	200, 202, 204
819.875	198, 206, 216, 218
819.883	148
820.229	430, 472, 474, 492
820.262	588, 590, 596
820.393	198
820.458	604, 610, 614
820.490	1004, 1012, 1014, 1040, 1042, 1044
820.750	504
820.850	506
820.860	506
820.911	430, 472
820.938	492
821.012	489
821.020	427, 429, 433, 477, 479, 503
821.290	745, 1105
821.630	616
821.950	614, 620, 622
822.390	191, 193, 195, 197, 199
822.430	20
822.480	125, 127, 191
823.290	1150, 1152
823.400	23, 41, 583, 593, 595, 607, 613, 615, 617, 619, 621, 623, 625, 627, 629, 947, 1113, 1115, 1117, 1119, 1135, 1137
823.470	629
823.931	172, 174
823.941	172, 174
823.951	172, 174
824.990	218
825.042	15, 19, 21, 37, 39, 89, 91, 129, 131, 133, 135, 137, 139, 141, 143, 145, 147, 149, 151, 177, 179, 181, 183, 185, 415, 417, 425, 427, 429, 437, 471, 685, 687, 693, 695, 697, 705, 719, 735, 763, 781, 799, 805, 837, 839, 841, 843, 845, 847, 849, 851, 853, 865, 881, 883, 893, 1085, 1087, 1089, 1091
825.050	43, 45, 209, 227, 229, 231, 233, 245, 247, 249, 255, 257, 259, 431, 433, 473, 475, 477, 489, 493, 563, 565, 779, 875, 1147
825.345	588, 596
825.354	589
825.361	588
825.612	1099
825.639	1029, 1043, 1097, 1099
826.219	200, 202
826.227	149, 199, 203, 205
826.235	202
826.308	203
826.596	200, 202
827.312	432, 434, 476, 478, 480, 502, 530

elring Das Original	
827.585	425
827.592	425
827.606	82, 84
827.819	534
827.843	604, 610
828.425	692
828.434	693, 705
828.564	588, 596
828.620	594, 596
828.807	86, 88, 92, 118, 120
828.913	604
828.998	728
829.005	728
829.056	73, 83, 85, 87, 89, 93, 101, 103, 113, 119, 121, 127, 129, 131, 133, 139, 149, 177, 179, 181, 183, 185, 199, 201, 203, 205, 207, 209, 211, 215, 217, 219, 227, 229, 231, 233, 245, 247, 249, 251, 253, 255, 257, 259, 263, 361, 371, 1085, 1087, 1147
829.307	177, 183, 199, 203
829.323	605
829.473	1039, 1079
829.986	430, 472
829.994	430, 472
830.283	526, 538, 540, 554, 556
830.305	526, 538, 540, 554, 556
830.313	526, 538, 540, 554, 556
830.489	653, 657, 659, 663
830.773	128, 130
832.245	1037, 1081, 1095
833.169	503, 533
833.258	432, 434, 436
833.274	421, 475, 489
834.009	422, 424
834.182	1096, 1098
834.262	605, 611, 615
834.300	86, 118, 120
834.440	488
834.793	613, 617
834.823	687, 695, 697, 715, 717, 719, 785, 787, 795, 799, 801, 803, 805, 865, 889
835.080	422, 424
835.099	423, 425, 437, 471
835.102	423, 425
835.684	426
835.692	427, 429
840.120	786
840.980	1098
841.060	1100
841.200	1099, 1101
842.000	606
842.660	335
843.040	167, 169, 173, 175, 177
843.833	24, 26, 914
845.060	1143
845.550	625, 627, 629
846.160	629
847.000	600

elring Das Original	
847.090	190
847.100	190
848.390	685, 815, 817
849.870	781
850.271	728, 730, 734, 736
850.641	780
850.650	781
851.091	764, 940
851.101	762
851.110	726
851.292	732, 750, 754, 756, 758, 760, 774, 896, 934, 936
851.361	750, 754, 756, 758, 760, 774, 934, 936
851.550	751, 755, 757, 759, 761, 775, 935, 937
851.560	750, 754, 756, 758, 760, 774, 934, 936
853.310	627, 629
854.010	664, 968
854.020	664, 968
854.180	603, 795, 797, 803
855.200	617, 619, 621
855.670	1099, 1101
858.050	123, 125, 187, 189, 219, 267, 281, 283, 285, 289, 291, 293, 295, 297, 299, 301, 305, 309, 313, 317, 319, 321, 333, 335, 367, 381
858.060	317, 319, 381
858.670	786
858.930	957
860.130	94, 96, 154, 156, 158
860.780	167, 169, 173, 175
861.510	880, 882
862.553	36
862.602	702
862.612	702
862.622	702
862.632	702
862.642	702
862.940	958
862.950	958
862.960	958
863.080	782, 784, 962, 964
863.110	782, 784, 962, 964
863.120	782, 784, 962, 964
863.130	782, 784, 962, 964
863.150	962
863.160	962
863.170	962
863.590	100, 102, 104, 106, 108, 110, 112, 114, 116, 210, 212, 214, 232, 234, 236, 238, 250, 252, 258, 260, 262, 264, 360, 362, 370, 376
863.980	958
864.221	1001, 1009, 1011, 1031, 1035
864.450	166, 168, 172, 174, 176
864.540	684, 814
866.830	1152
867.540	686, 696, 864
867.570	798, 804
867.700	888
867.720	652

elring Das Original	
867.800	776, 946
868.220	742, 744, 770, 1104
868.260	744, 770, 1104
870.780	795
872.110	795
872.240	802
872.250	764, 940
872.500	704
872.510	704
872.520	704
872.530	704
872.540	704
874.301	1083, 1113, 1119, 1129, 1135
875.350	24, 26, 28, 30, 910, 912, 914, 916, 918
875.490	37
875.620	795
875.770	612
876.260	1151, 1153
876.861	325
876.880	325
877.090	80
877.100	81
877.300	190, 192, 194, 196, 198
877.311	328
877.340	124, 126, 190
877.351	328
877.361	328
877.372	328
877.422	328
877.452	328
877.740	786, 788, 966, 968
877.840	653, 657, 665
877.870	419, 541, 543, 545, 547, 549, 551, 553, 559, 561
877.900	1103
877.910	43, 45, 779, 783, 785, 949, 951, 953, 957, 961, 963, 965, 967, 1143, 1145
877.920	15, 17, 19, 21, 23, 25, 27, 29, 31, 33, 35, 37, 39, 41, 43, 639, 641, 643, 645, 647, 649, 883, 885, 887, 893, 903, 905, 907, 909, 911, 913, 915, 917, 919, 921, 925, 927, 937, 939, 953, 955, 957
877.930	699, 701, 703, 707, 709, 711, 713, 733, 747, 755, 757, 759, 761, 771, 773, 877, 897, 929, 937, 945, 1015, 1017, 1019, 1021, 1025, 1027, 1105, 1121
877.940	417, 419, 421, 429, 445, 447, 449, 459, 565
877.950	705, 733, 737, 739, 741, 749, 751, 753, 755, 757, 759, 761, 763, 765, 767, 769, 773, 775, 895, 897, 899, 901, 929, 931, 933, 935, 937, 939, 941, 943, 945
877.960	685, 815
878.020	563, 663
878.030	17, 29, 31, 33, 35, 37, 639, 641, 643, 645, 647, 649, 883, 885, 887, 917, 919, 925, 927
878.040	783, 785, 955, 957, 959, 963, 965, 967, 1143, 1145
878.070	73, 83, 85, 87, 89, 93, 119, 121, 127, 129, 131, 133, 135, 137, 139, 141, 145, 149, 177, 179, 181, 183, 185, 199, 201, 203, 205, 207,

elring Das Original	
878.080	209, 217, 219, 229, 233, 247, 251, 255, 259, 1085, 1087, 1091, 1147
878.100	101, 103, 109, 111, 113, 201, 203, 209, 229, 233, 247, 259
878.110	269, 271, 273, 327, 329, 337, 341, 343, 349, 351, 353, 383
878.160	9, 11, 13, 15, 637, 639, 837, 839, 841, 865, 867, 869, 871, 873
878.330	746
878.490	125, 127, 191, 193, 195, 197
879.280	840
880.342	23, 25, 29, 31, 905, 907, 909, 911, 913, 915, 917, 919, 921
880.342	946
884.050	593
884.060	593, 595
884.220	742, 744, 770, 1104
884.230	745, 771, 1105
884.561	1149
886.410	593
886.920	594
887.260	592
888.320	841
888.346	431, 473, 475, 493
888.354	475, 535, 537
888.389	474, 534, 536
888.410	8, 636, 836, 838, 840
888.435	422
888.508	423, 425
888.516	425, 431, 473, 493
888.524	433
888.605	433, 477, 479, 503
888.979	414, 416, 424, 426
888.986	414, 416, 424, 426
889.194	502, 532
889.650	842
889.680	862
890.320	802
890.800	652
890.952	955, 957, 961
891.312	432, 476
891.348	82, 84
891.356	82, 84
891.364	82, 84
891.780	92
891.991	475, 535, 537
892.009	802, 804
892.106	430, 472, 474, 492
892.122	535, 537
892.130	475
892.177	472
892.564	72
892.815	1012, 1014
893.242	83, 85
893.420	488
893.600	721, 723, 725
893.617	472, 474
893.650	419, 721, 723, 725

elring Das Original	
893.749	414, 424
893.765	436, 470
893.773	436, 470
893.781	436, 470
893.812	476, 478, 480, 482, 484, 494, 496
893.838	432
893.846	476
894.060	86, 120
894.605	488
894.613	488
894.656	489
894.699	502
894.729	502
894.738	502, 532
894.772	601
895.440	699, 723
895.670	603
896.200	129
896.691	1028
896.710	732, 896
896.748	1042
896.760	794
897.290	558, 560
897.690	79, 95, 97, 99, 101, 153, 155, 157, 159, 161, 163, 165, 167, 169, 171
897.840	607, 609
897.900	1130
898.042	72, 74, 76, 360
898.100	698, 722
898.110	698, 722
898.130	606, 608
898.171	446, 448
898.272	74
898.310	783, 785, 955, 957, 959, 961, 963, 965, 967
898.340	184
898.460	152, 154
898.480	152, 154
898.510	152, 154
898.600	94, 96, 154, 156, 158
898.610	340, 342, 344, 346, 348, 384
898.620	340, 342, 344, 346, 348, 384
899.887	200
900.001	692
900.380	354
901.490	354
901.630	721
901.840	773, 945, 1121
902.150	560
902.230	490, 492, 518, 520, 522, 524
902.380	735
902.561	159, 163, 165, 167, 169, 171
902.760	641, 643, 661, 885, 887, 895
902.860	415, 457, 459, 491, 499, 501, 519, 521, 523, 525
903.201	122, 124, 186, 188, 364, 366
903.210	446
903.220	446, 448



903.340	470, 486, 498
903.350	470, 486, 498
903.580	640
903.590	640, 642, 884, 886, 894
903.600	1107, 1109, 1111, 1123
904.750	802
904.780	152, 154
904.900	721, 803
905.590	480, 482, 484, 494, 496
905.600	486, 498
905.610	486, 498
906.110	622, 624, 626, 660
906.380	652
906.550	804
907.040	1152
907.080	592
907.170	702, 704, 1022
907.240	702, 704, 1022
907.400	17, 33, 639, 641, 643, 645, 647, 649, 887, 925, 927
907.560	653
907.570	665, 667
908.400	280, 282, 286, 288, 290, 292, 294, 296
910.610	703, 705, 1023
910.680	592, 594
910.710	592
910.720	592
911.090	606
911.180	593, 595
911.240	841
911.360	690
911.980	592, 594
912.430	840
912.510	614, 620
912.980	9, 837
914.012	421
914.033	502, 530
914.398	148, 200, 202, 204
914.401	426
914.452	562
914.460	562
914.495	476, 478, 480, 482, 484, 494, 496
914.500	526, 540
914.518	526, 538, 540, 554, 556
914.525	540
914.533	540
914.657	426
914.848	128, 130
914.856	128, 130
914.873	128, 130
914.991	206
915.009	128, 130, 132, 138, 144, 206, 1084, 1086
915.017	128, 130, 132, 138, 144, 206, 1084, 1086
915.050	364
915.130	128, 130
915.160	364, 368, 370



915.173	206
915.213	129, 131, 133, 135, 137, 139, 141, 143, 145, 147, 149, 151, 1085, 1087, 1089, 1091
915.238	207, 219
915.297	89, 179, 181, 185
915.300	179, 183
915.311	199, 201, 203
915.491	204
915.572	198, 200, 202
915.591	126, 176, 178, 180, 182, 184
915.629	148
915.653	86, 88, 90, 178, 180, 182, 184
915.947	204
915.963	204
915.971	178, 180, 182
915.998	86, 176, 178, 182
916.005	1056, 1058, 1060, 1062, 1064, 1066, 1068, 1070, 1072, 1074
916.261	1007, 1009
916.295	997, 1001, 1007, 1009
917.699	176, 182
917.710	198, 216
917.842	1146
917.893	1147
917.908	1146
917.915	1147
917.958	1147
917.966	1146
918.024	837, 839
919.382	597
919.497	588, 590, 596
919.500	596
919.829	729, 739, 741, 899
919.934	1068, 1070, 1072
919.942	1056, 1060, 1068, 1070
919.950	1056, 1060, 1068, 1070
919.969	1056, 1060, 1068, 1070
919.977	1069, 1071, 1073, 1075
919.985	1057, 1059, 1061, 1063, 1065, 1067, 1069, 1071, 1073, 1075
919.994	1057, 1059, 1061, 1063, 1065, 1067, 1069, 1071, 1073, 1075
920.762	1076
920.770	1076
920.789	1077
920.797	1077
921.093	209, 229, 231, 247, 251, 255, 257
921.107	209, 227, 231, 245, 251, 255, 257
921.513	1056, 1058, 1060, 1062, 1064, 1066, 1068, 1070, 1072, 1074
923.096	538
923.100	538
923.118	538
923.126	538
925.600	1142
925.990	8, 836
926.020	28, 30, 912, 916, 918, 920
926.150	795



926.370	639, 869, 871, 873
926.670	638, 642
926.680	638, 642
926.700	22, 40
926.710	22, 40
926.720	32, 34, 36, 644, 646, 648, 924, 926
927.100	664, 666
927.300	804
927.380	616
927.470	802
927.480	616
927.570	613
927.910	620
927.920	614, 620
927.930	580, 582, 584
927.950	620, 622
928.210	1150, 1152
928.270	795
928.280	794
928.300	267, 269, 319, 321, 381
928.420	628
928.580	581, 583, 585
928.760	12, 14, 636, 638, 866, 870, 872
928.770	12, 636, 638, 866, 870, 872
928.780	298, 302, 306, 310, 312
928.790	12, 14, 636, 638, 868, 870, 872
928.870	796
928.890	888
928.940	888
928.950	712
928.960	80
928.970	742, 744, 770, 1104
928.980	684
928.990	688
929.060	702, 704, 1022
929.340	592
929.530	581, 583, 585
929.580	703, 705
929.890	704
934.350	957
934.550	957
935.290	612
935.310	612, 620
935.330	620
935.740	614
935.780	581, 583, 585
938.240	266, 268, 318, 320, 380
938.250	266, 268, 318, 320, 380
938.260	581, 583, 585
938.620	581, 583, 585
938.990	615
939.080	1152
939.090	1153
939.340	641, 643, 885, 887, 895
939.400	12, 14, 638, 868, 870, 872
939.490	640, 884, 886

 Das Original	
940.040	665, 667
940.060	665, 667
940.160	592, 594
940.290	956
940.450	11, 639, 867, 871, 873
940.460	32, 34, 926
940.491	647, 649, 927
940.510	652
940.520	652
940.530	664, 666
940.580	957
940.640	957
940.740	956
940.750	956
940.760	956
941.640	615
942.790	956
942.990	665, 667
944.000	12, 14, 638, 868, 870, 872
944.110	1047, 1049, 1051, 1053, 1055, 1057, 1059, 1061, 1063, 1065, 1067, 1077
944.170	12, 14, 638, 868, 870, 872
944.190	12, 14, 872
944.220	12, 14, 872
945.470	712, 734
945.680	606
945.730	665, 667
945.740	665, 667
946.050	606
947.790	581, 583, 585
948.660	123, 125, 187, 189, 365, 367
949.350	8, 636, 836, 838, 840
949.360	640, 642, 884, 886, 894
949.390	664, 968
952.850	811, 815, 817, 819
953.630	1105
954.350	306, 310, 312
954.360	306, 310, 312
964.160	703, 705, 1023
964.581	742, 744, 770, 1104
966.260	956
966.950	703, 705, 1023
967.050	702, 704, 1022
967.060	702, 704, 1022
967.070	702, 704, 1022
968.160	688
972.940	580, 582, 584
980.870	600
982.100	98, 100, 160, 162, 164, 168, 170
982.110	98, 100, 158, 160, 162, 164, 166, 168, 170
982.340	217, 225, 241, 243, 265, 267, 269, 271, 273, 275, 277, 279, 281, 283, 285, 287, 289, 301, 315, 317, 319, 321, 323, 325, 333, 337, 339, 341, 343, 345, 347, 349, 353, 369, 373, 375, 377, 379, 381, 383, 385
984.118	692
984.125	684, 686, 692, 694, 696
984.136	686, 692, 694, 696, 864

 Das Original	
984.208	802
984.216	802
984.224	802
984.285	802, 804
984.290	802
984.427	712, 714, 726, 734, 894
984.451	685, 687, 693, 695, 697, 865
984.478	803
984.604	650
984.704	650
984.817	728, 730, 734, 736, 738, 740, 898, 900, 902
984.826	685, 687, 693, 695
985.385	651
985.880	836, 838
986.283	862
986.305	958, 960
986.373	32, 890, 920, 922
986.381	32, 890, 920, 922
986.390	32, 890, 920, 922
986.496	956, 958
986.518	956, 958
986.748	684, 686, 692
987.043	798
993.440	607
993.450	606
994.470	880
995.530	795
995.620	698, 706, 708, 876, 1026



Notizen

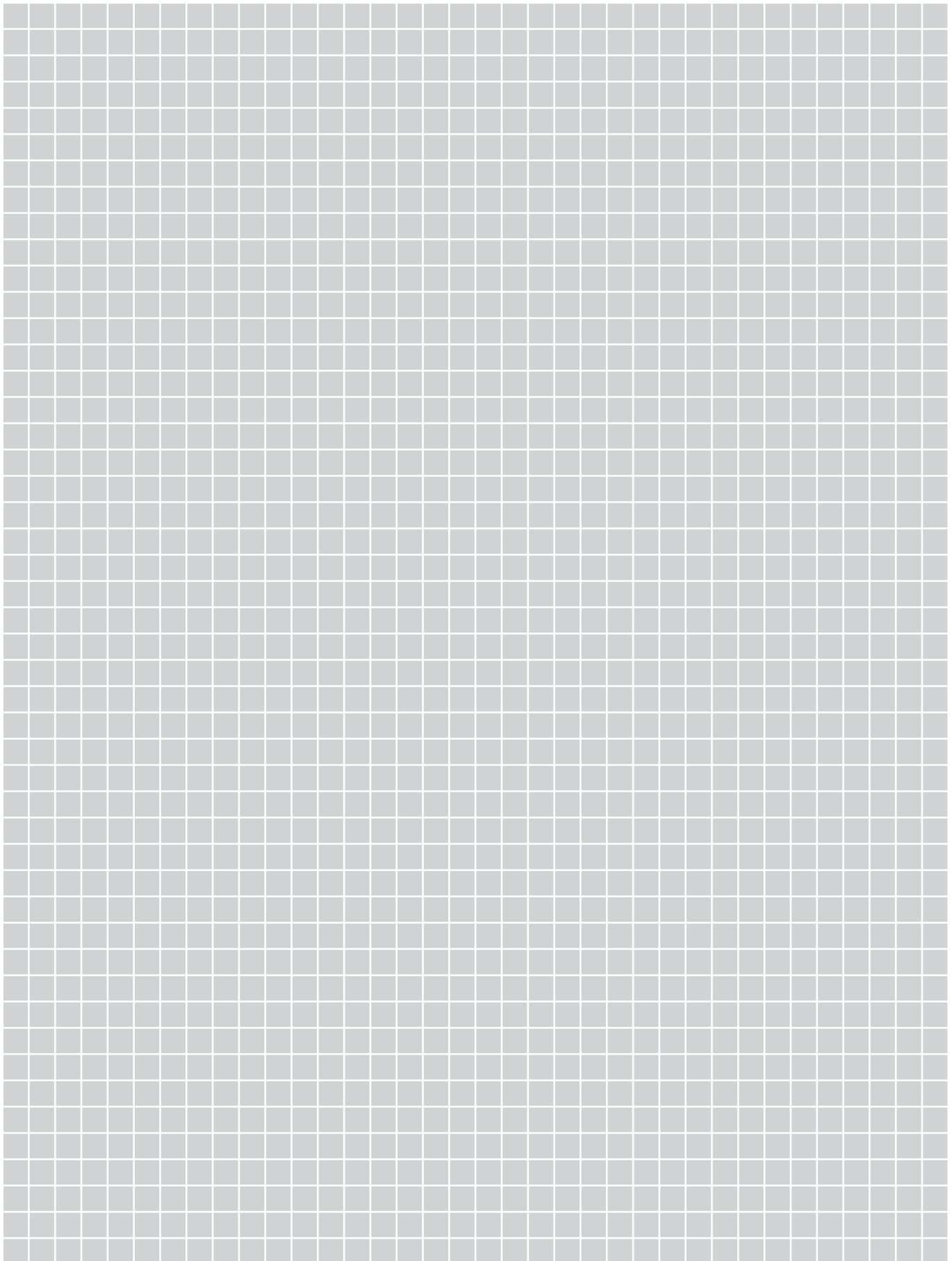

Notizen

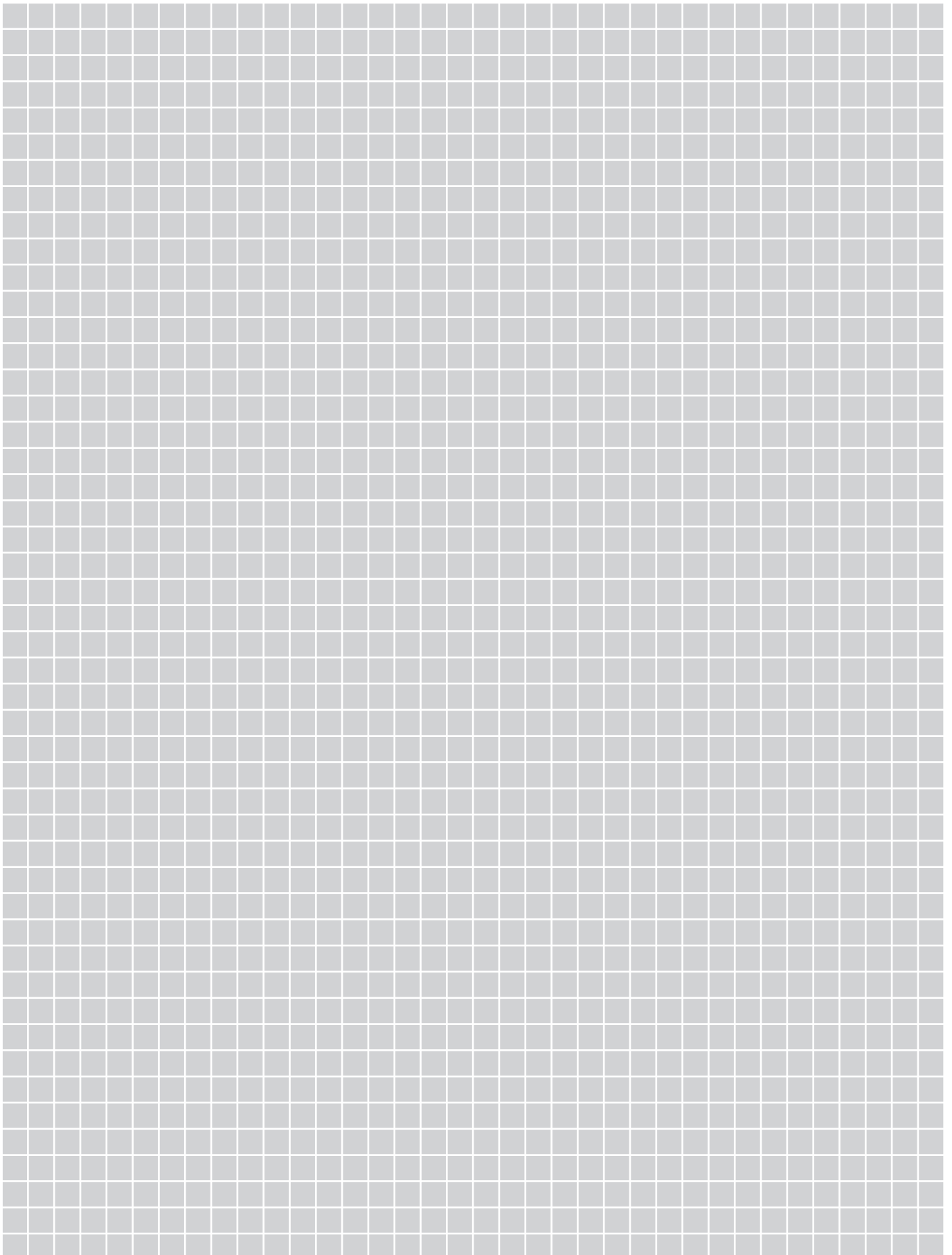



Notizen

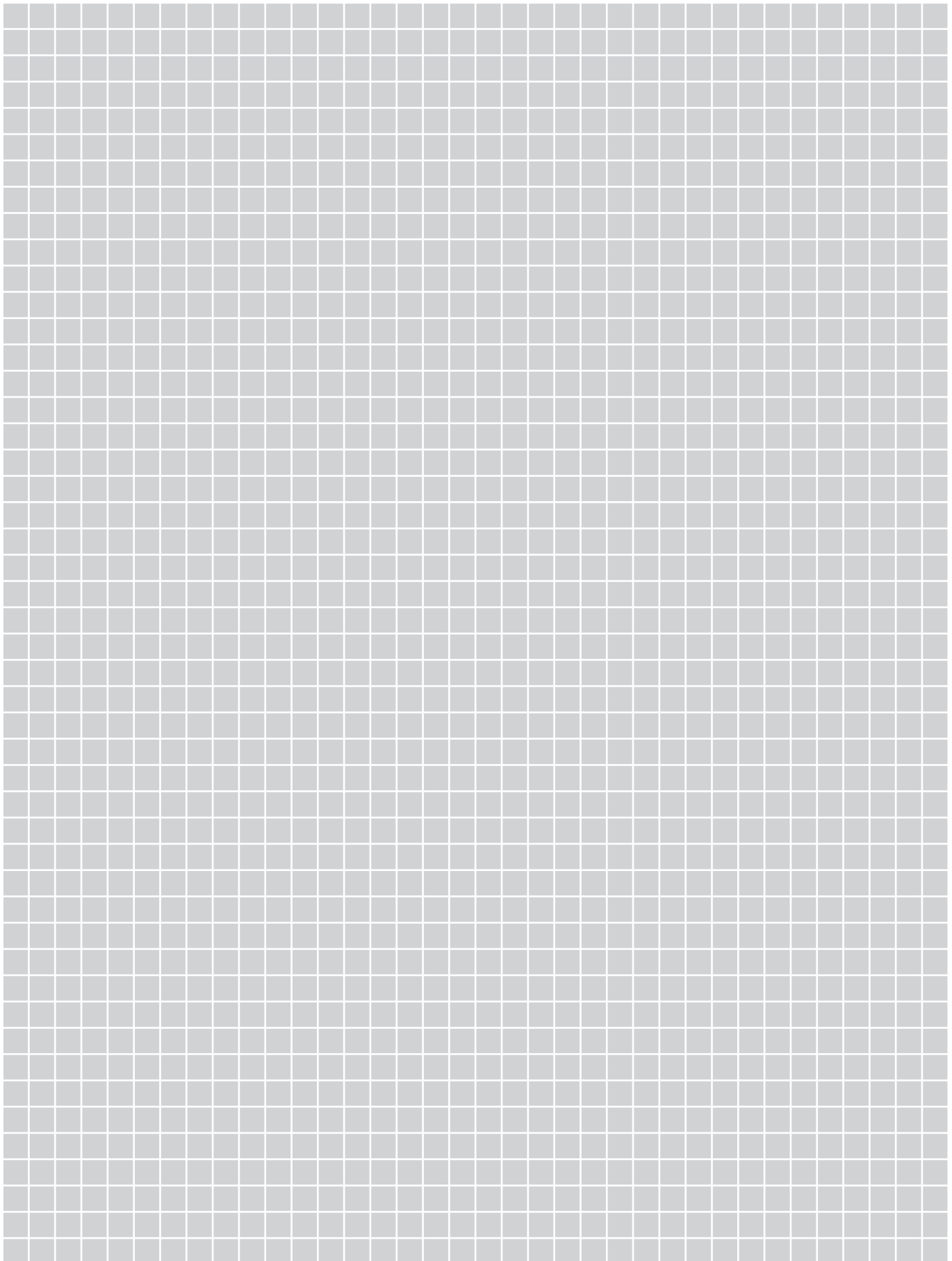

Notizen

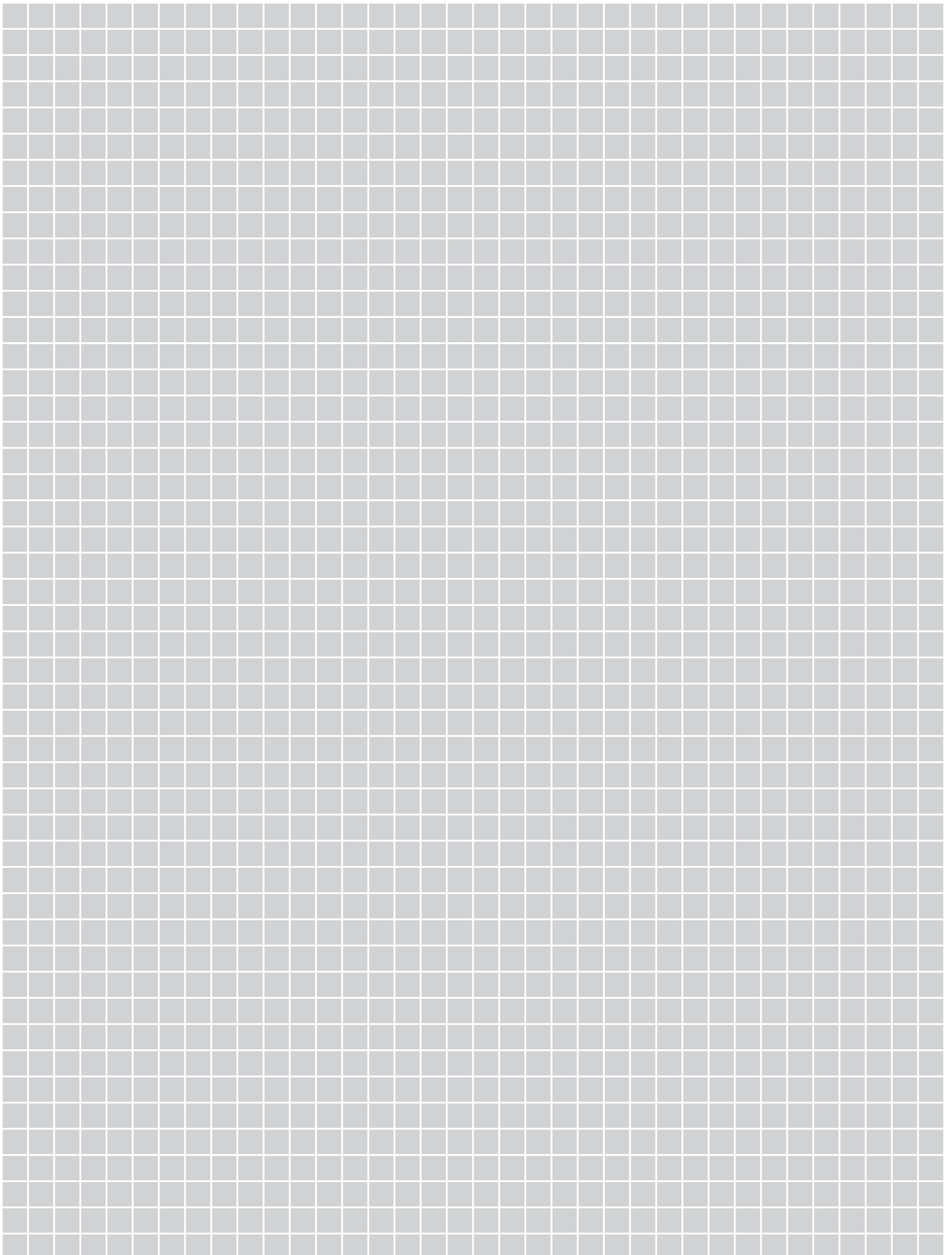



Notizen

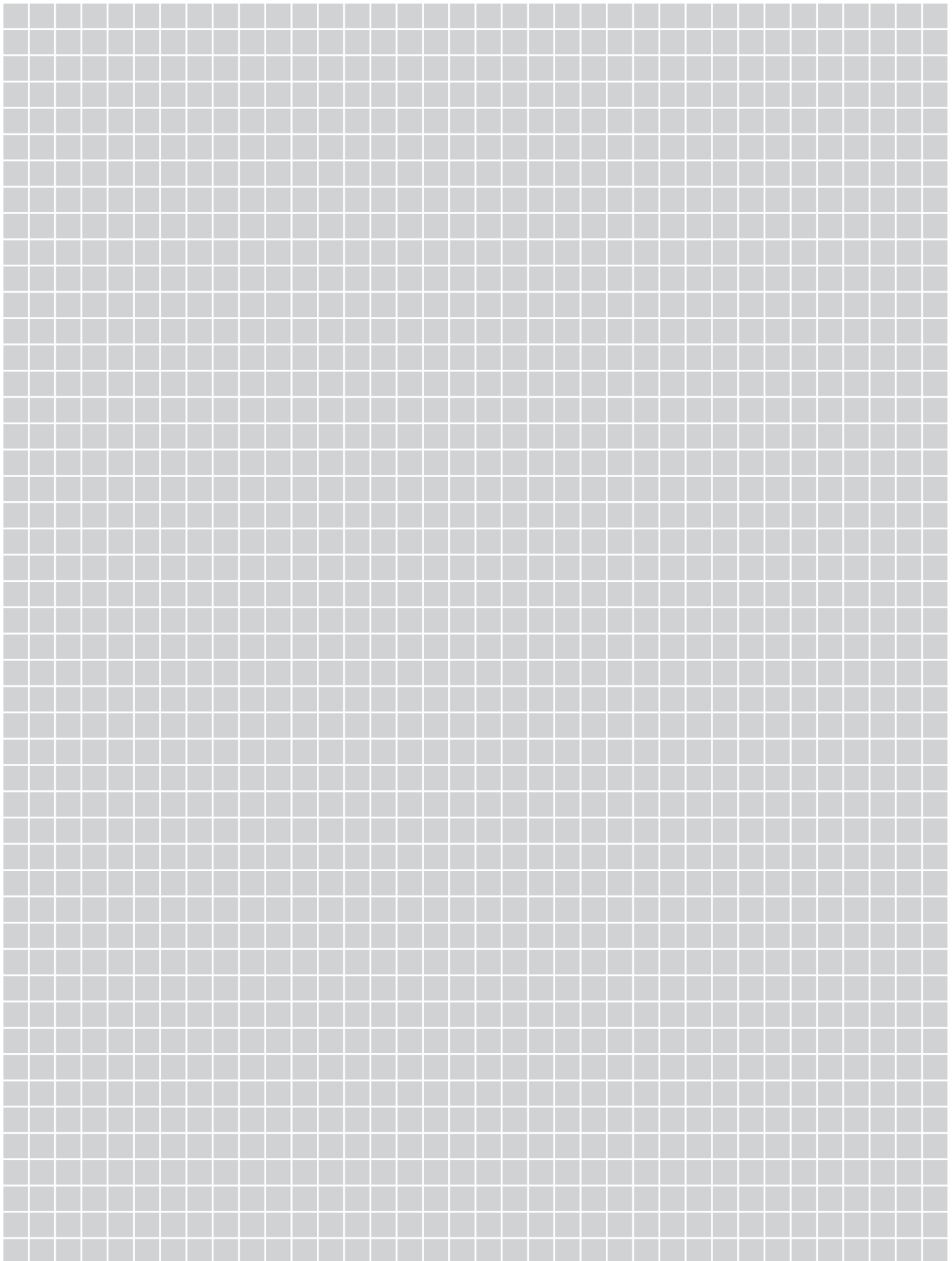

Notizen

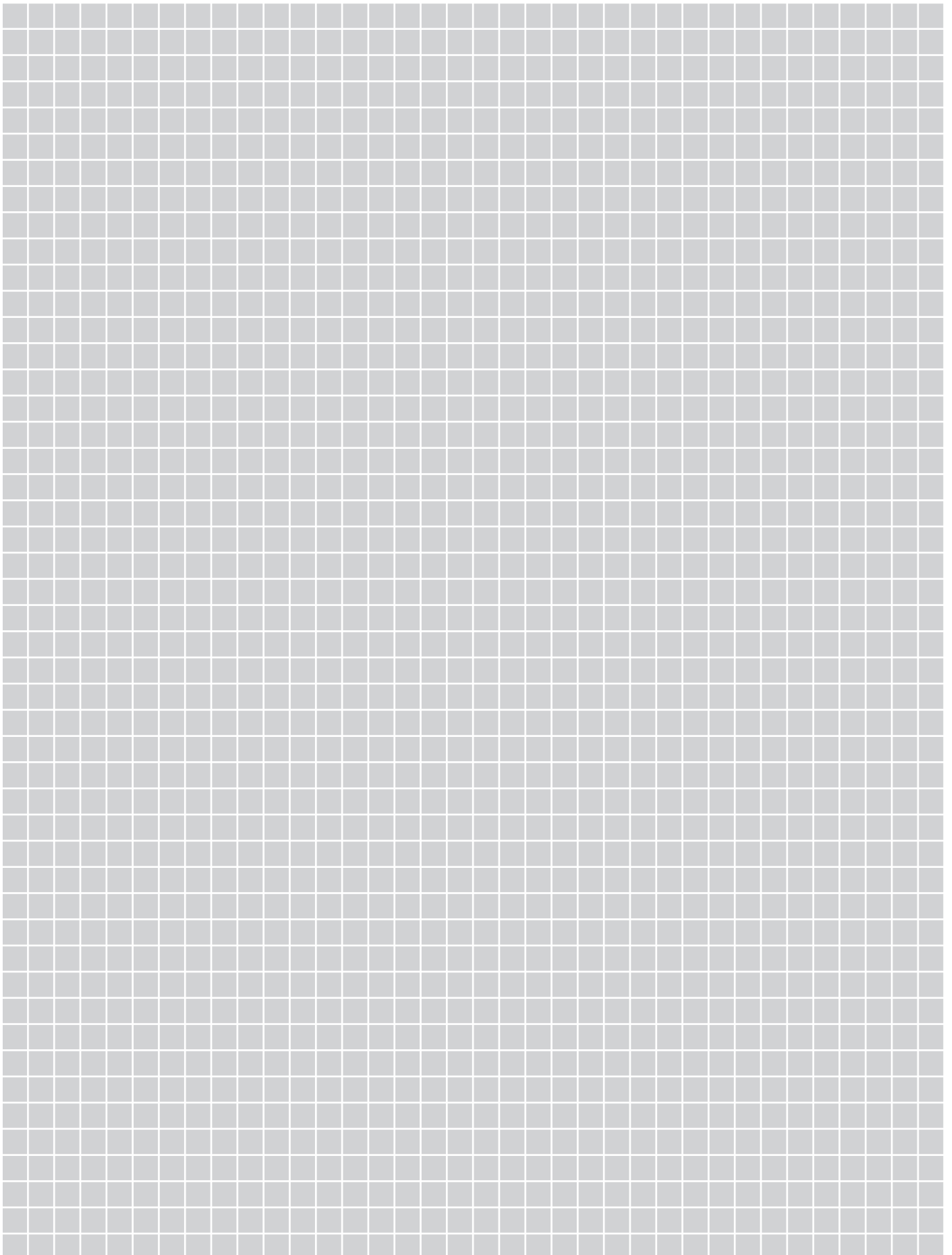



Das Original



YouTube



Website



Instagram



Online
Catalog



Facebook



Service
Information



WeChat



Products



Monthly
Newsletter

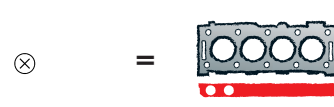
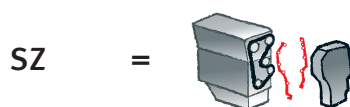
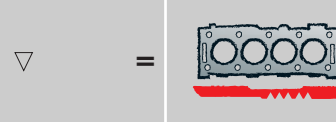
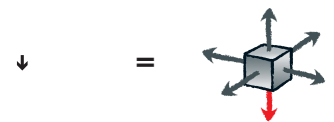
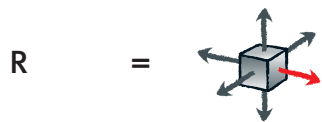
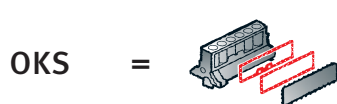
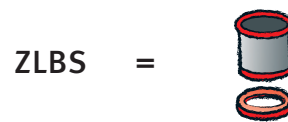
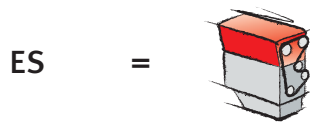
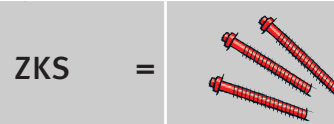
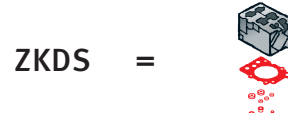
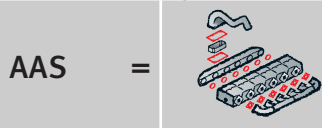
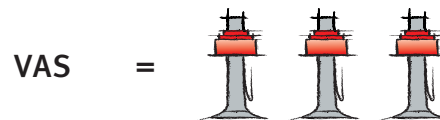

Elring Academy



www.elring.de/en/academy



Das Original



Elring-Service-Hotline

 +49 7123 724-799

service@elring.com

ElringKlinger AG | Aftermarket Division
Max-Eyth-Straße 2 | 72581 Dettingen/Erms | Germany
Phone +49 7123 724-799 | Fax +49 7123 724-798
service@elring.com | www.elring.com

C510300 0822



Das Original

Keine Gewähr bei Druckfehlern. We are not liable for printing errors. Toute garantie exclue pour les fautes d'impression. Se declina toda responsabilidad por erratas de imprenta. Si declina ogni responsabilità per eventuali errori di stampa. Возможны опечатки.